



Flow control Gas control systems

Precise gas control for exact analyses

We make ideas flow.

bürkert
FLUID CONTROL SYSTEMS



Developing high-quality analytical lab devices

When developing high-quality analytical lab devices, you, as a manufacturer, attach great importance to stable measurement results and application-specific functionalities. Precise gas control and repeatability of the devices contribute significantly to consistent and reliable measurements.

Controlling gases systematically

In research processes, instrumental analytics utilises analytical lab devices to measure, analyse and verify material properties and correlations. It therefore relies on high-precision measuring principles. This includes the spectroscopy method, which is subdivided into atomic absorption spectroscopy (AAS), atomic emission spectroscopy (AES) and mass spectroscopy (MS). Each measuring method

works with different gases. Another measuring method is gas chromatography (GC), which utilises inert gases such as nitrogen, helium or hydrogen. The following applies irrespective of the measuring principle: Precise and repeatable control of the gases used is essential for exact measurement results. This is where Bürkert gas control systems come to the fore.

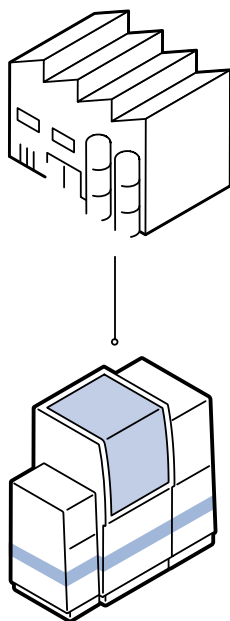

Product

How can a space-saving and integrated gas dosing system help in the production of your analytical devices? Read the following pages to discover the competitive advantages offered by Bürkert gas control systems.

Specific requirements and the upward pressure on prices

Specific requirements and the upward pressure on prices influence the analyser market. The current trend is towards application-specific analytical devices with compact components. Modular assemblies for gas dosing not only save

space, they also help to reduce your manufacturing costs – thanks to shorter construction periods and less expenditure for logistics and services.

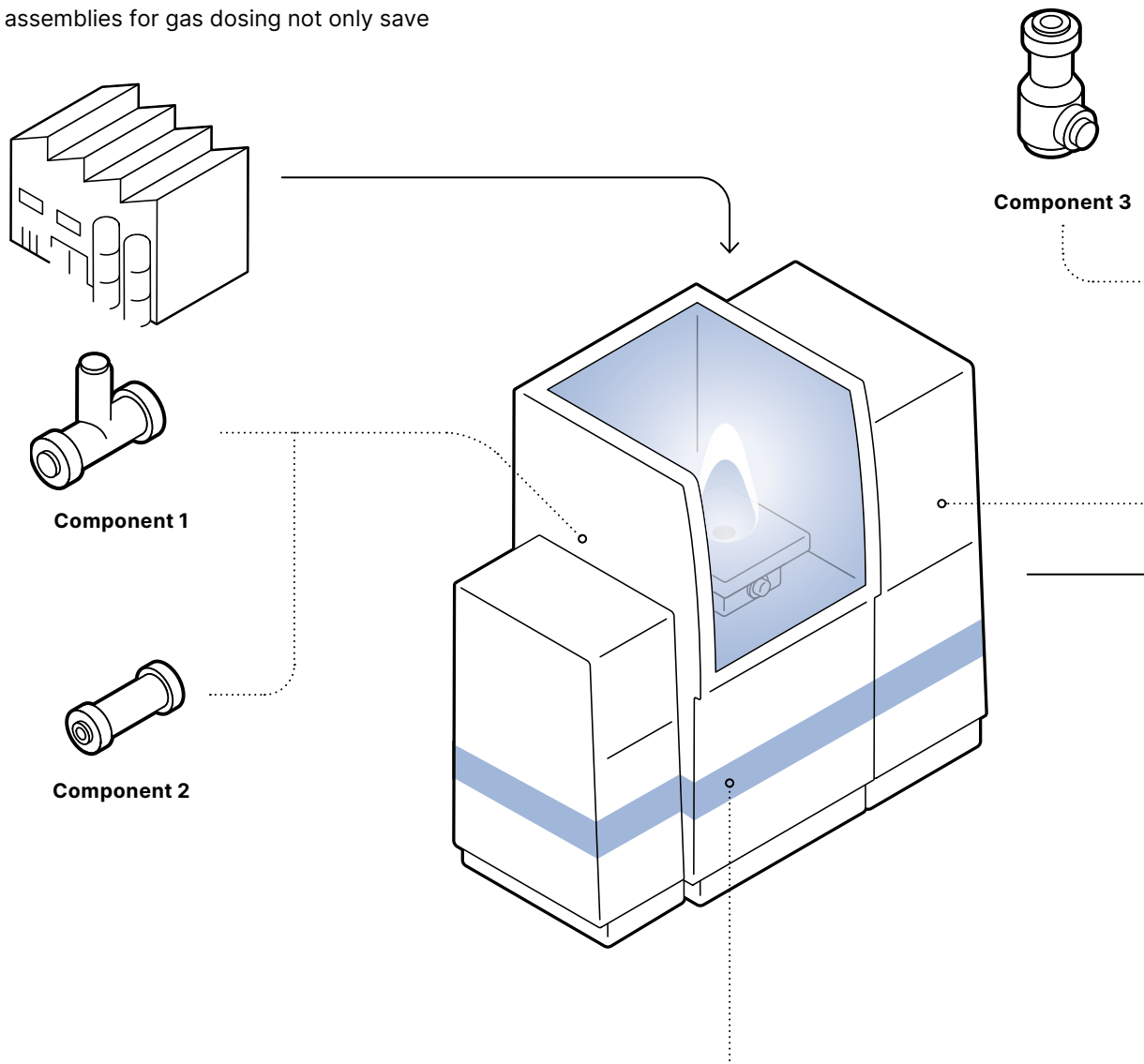

Gas control systems for specific requirements

Customer-specific solutions for the precise control of gases are available for specialised analytical devices. They are geared towards certain analytical methods. The compact and cost-optimised solutions can be easily integrated into the analytical device.



Costs

To remain interesting in terms of price, many analytical devices offer just a few functionalities tailored to the actual field of application. An extensive control range facilitates standardisation of the devices. Customer-specific assemblies for gas dosing save space in the device and reduce the expenditure for installation.

Conventional solution

Special, unique components are used to solve individual tasks in the overall system. Associated with this is the expenditure for the procurement and testing of components as well as for the engineering and design of the respective gas control system.

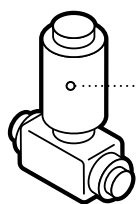

Component 4

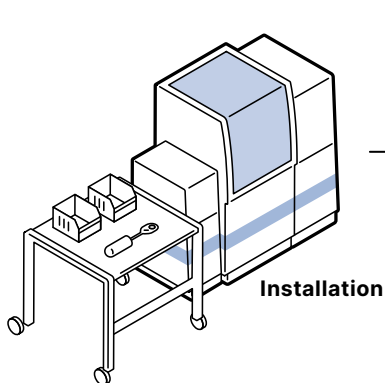

Installation

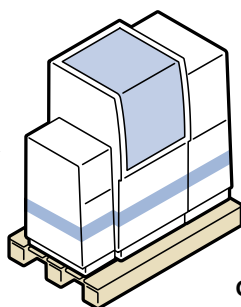

Goods issue

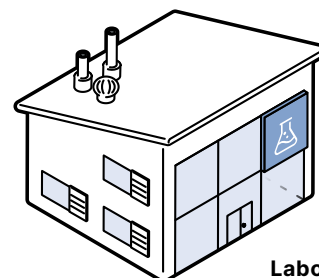
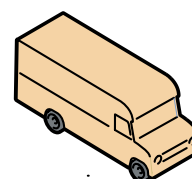

Laboratory

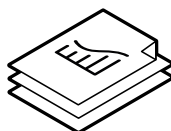

Analysis



Measured values

Stable measurement results and high repeatability are key factors of an analytical device. Bürkert gas control systems are, therefore, designed for reliable and consistent analysis processes – with a low number of sealing points, short flow channels, etc.

Pre-configured gas dosing

The Multi-MFC system Type 8735 for gas control is the modular and cost-effective solution for all analytical devices that do not require highly specific integration. The multi-channel system consisting of various assemblies is semi-standardised, meaning parts can be replaced.

Development periods are very short due to the platform solution. The compact systems can be calibrated for various gases such as argon, helium, carbon dioxide, air, nitrogen, oxygen, methane, acetylene and hydrogen.

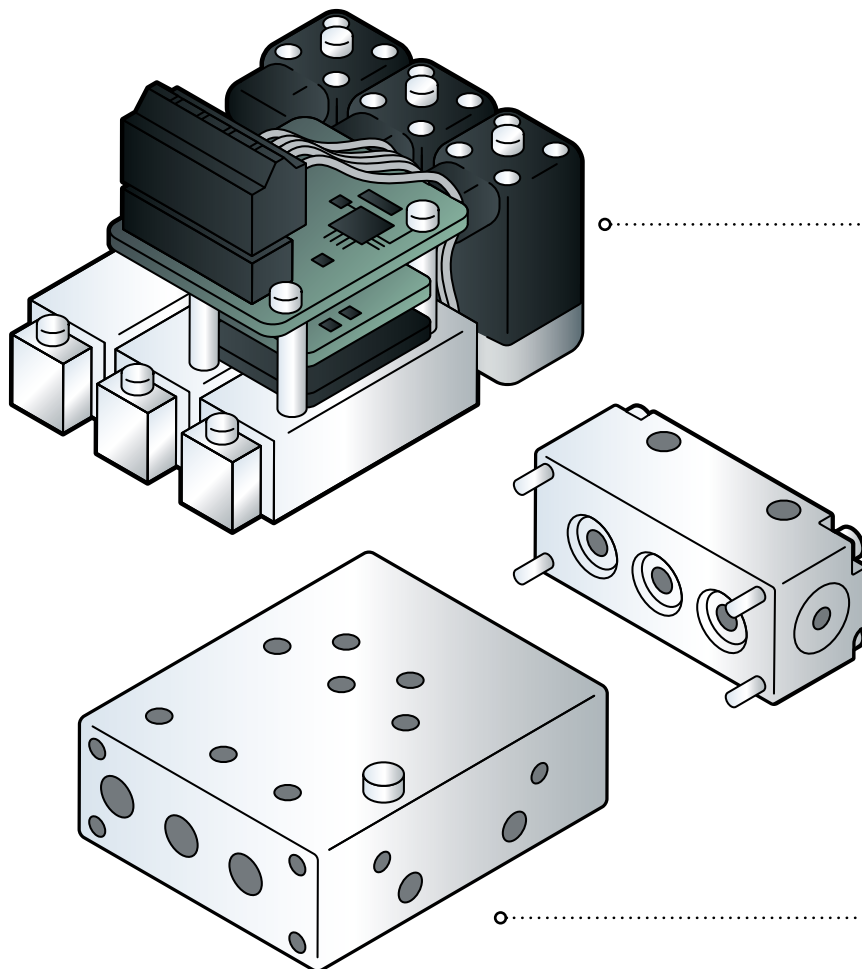

Multi-MFC system Type 8735

The flow control loop of a multi-channel system solution consists of a Mass Flow Meter Type 8736, a direct-acting proportional valve Type 2871, electronics with a PI controller and a communication interface.

Type 8735 – assembly variant

1. Mass Flow Controller (MFC)
2. Mass Flow Meter (MFM)
3. Optional assembly possible

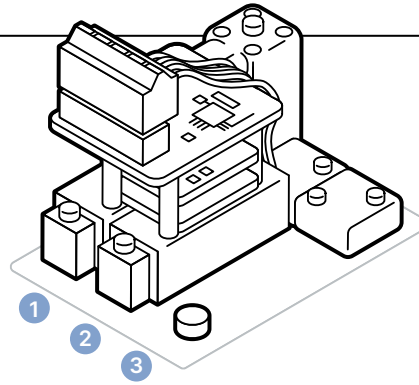

Additional modules

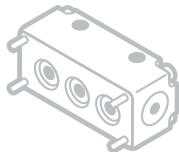

Collector / Distributor

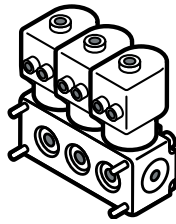

On/Off module

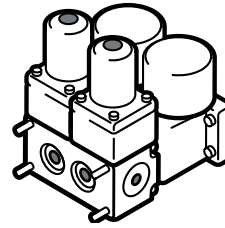

Pressure control module

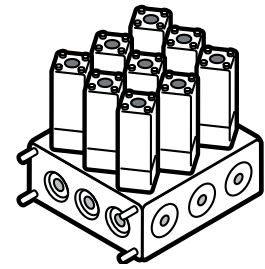

Multiplexer

Basic block – structure variant

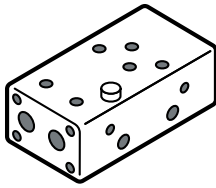

2-fold

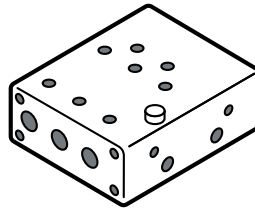

3-fold

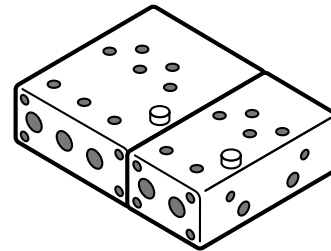

Combined



Modular design

System platform for customised built-in gas control systems with a short development period.



System expertise

Individual customer solutions and system extensions are created at the Bürkert Systemhaus facilities.



Maximum precision

Thermal sensors and direct-acting proportional valves provide maximum precision and quick reaction times.



Simple start-up

Simple cabling and project planning facilitate start-up.



Compact design

Ultra-compact gas control systems for optimum integration into analysers.

Highly integrated gas dosing

Fully customer-specific Bürkert gas control systems offer a maximum level of integration, tailored to your functional and fluidic requirements. This results in high-end systems for the qualitative and quantitative analysis of liquids, solids and gases in the environmental, food, pharmaceutical,

medical and agricultural sectors. Each system is unique. What they all have in common though is a compact design, a minimum number of sealing points and low tubing expenditure.

Optimum integration: The following applies to each Bürkert OEM system solution:

- Perfect integration according to customer requirements in terms of the electronic and data connection as well as the mechanical connection, e.g. the position and type of fluidic connections and attachment points in the analytical device (perfect ergonomics)
- Optimisation of flow channels to ensure the cost-effective production of the basic block
- Consideration of flow-specific requirements and a space-saving design
- Significantly reduced or no tubing or piping expenditure at all, but also integrated and thus already tested sealing points
- Individual electrical engineering (operating voltage, bus connection, plug)
- Customer-specific firmware, including application-specific functionalities
- Integration of various components, e.g. on/off valves for gas control, flow or pressure control systems, mechanical pressure controllers, check valves, line connections, switches and filters

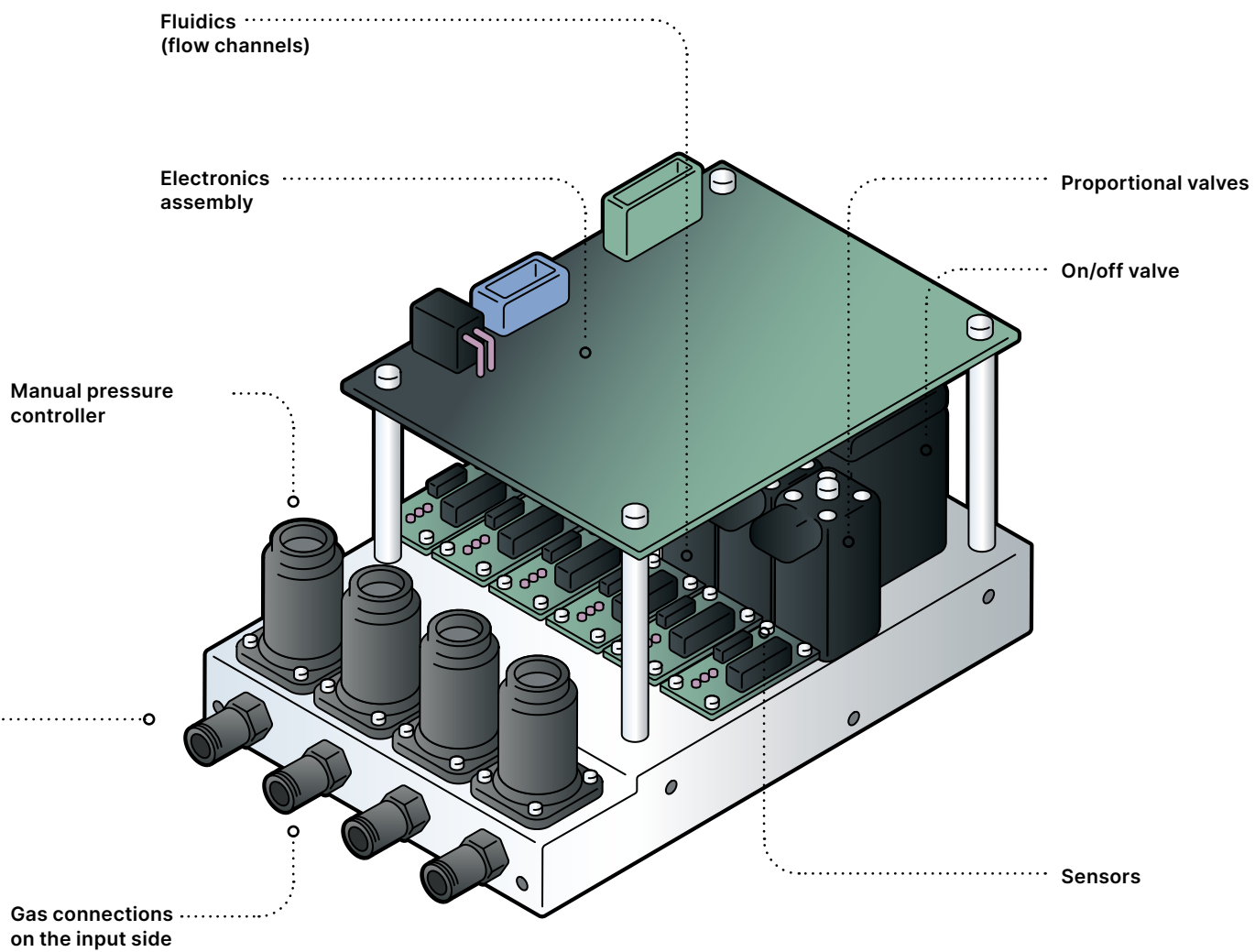

Gas control becomes a win-win situation with Bürkert

Whether you opt for a pre-configured gas control system Type 8735 or a highly integrated system – Bürkert’s range of products meets all the requirements of your customers.

Compared to a solution consisting of individual components, the decision in favour of a gas control system is definitely worthwhile:

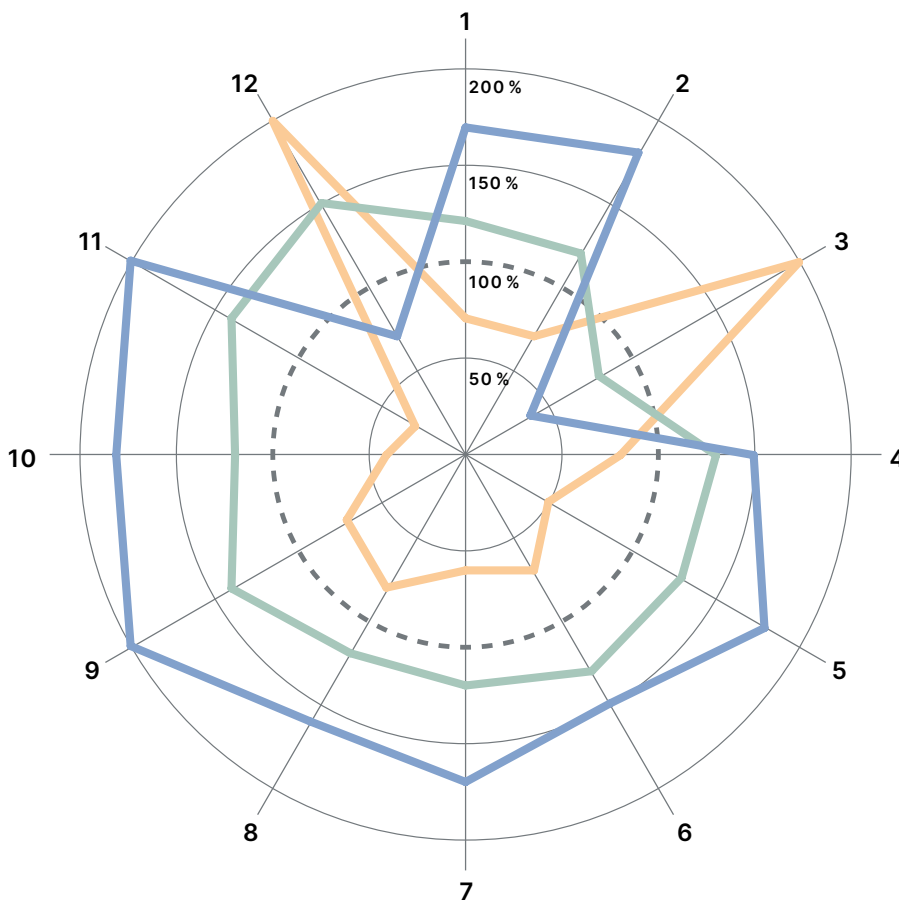

1. Minimum expenditure for the procurement process
2. Minimum expenditure for management and logistics
3. Low initial costs for provision of the product to be supplied
4. Low procurement costs
5. Minimum expenditure for installation
6. Minimum expenditure for testing
7. Minimum space required in the device
8. Greater competitive advantage
9. Implementation of your own concepts
10. Reduced number of additionally required components
11. Reduced number of interfaces, electrical and mechanical
12. Easy replacement of components

--- Reference line 100%

— Component solution

— Standardised Bürkert solution Type 8735

— Highly integrated Bürkert solution

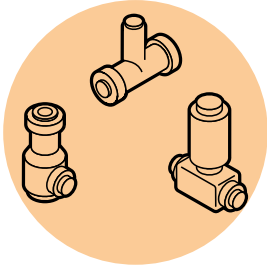

Component solution

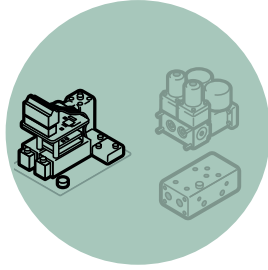

Standardised Bürkert platform
Type 8735

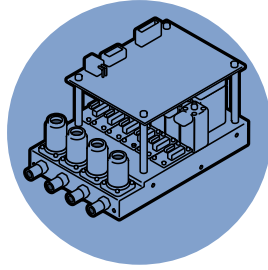

Highly integrated
Bürkert solution

			Minimum expenditure for the procurement process
			Minimum expenditure for management and logistics
			Low initial costs for provision of the product to be supplied
			Low procurement costs
			Minimum expenditure for installation
			Minimum expenditure for testing
			Minimum space required in the device
			Greater competitive advantage
			Implementation of your own concepts
			Reduced number of additionally required components
			Reduced number of interfaces, electrical and mechanical
			Easy replacement of components

Bürkert Fluid Control Systems
Christian-Bürkert-Straße 13-17
74653 Ingelfingen
Germany

Tel.: +49 7940 100
Fax: +49 7940 1091204

info@burkert.com
www.burkert.com

bürkert
FLUID CONTROL SYSTEMS