

Operating Instructions

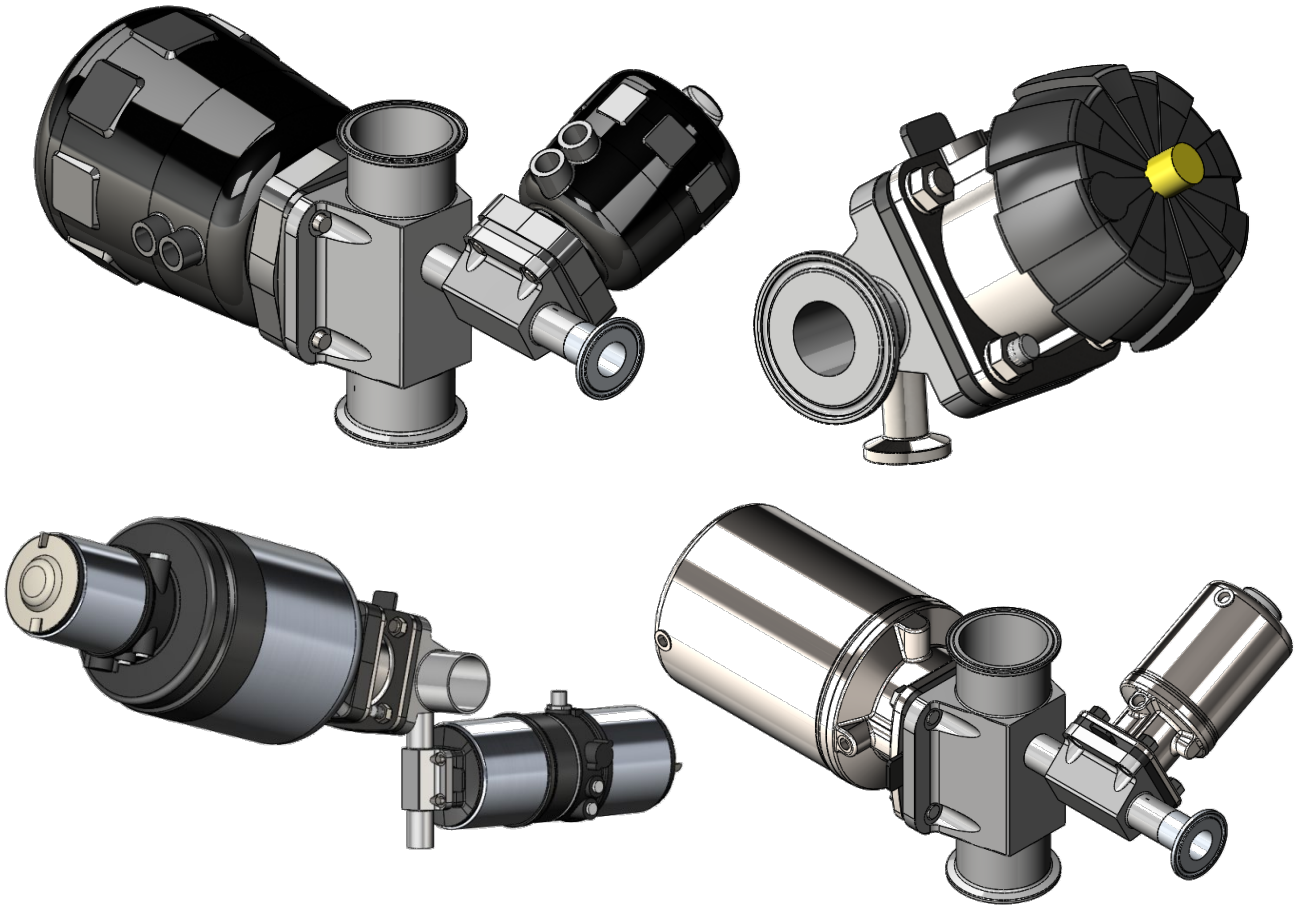

Beispielhafte Darstellungen/ Exemplary presentations

Typ / Type 2034-T

Aseptic Multiway Valve System

Bedienungsanleitung:

© 2017-2024 Bürkert Werke GmbH & Co. KG

Bedienungsanleitung 2408/0A_MI-ml_00810620 / Original DE

Table of Contents

1	OPERATING INSTRUCTIONS	4
1.1	Symbols	4
2	INTENDED USE	5
2.1	Restrictions	5
3	BASIC SAFETY INSTRUCTIONS	6
4	GENERAL INFORMATION	8
4.1	Contact address	8
4.2	Warranty	8
4.3	Information on the Internet	8
5	SYSTEM DESCRIPTION	9
5.1	Intended application area	9
5.2	General description	9
5.2.1	Label information	9
5.3	Operating instructions actuator; automation unit	11
5.3.1	Actuator	11
5.3.2	Automation unit for pneumatic actuators	12
5.4	Functions	13
6	TECHNICAL DATA	14
6.1	Operating conditions	14
6.2	General technical data	14
6.2.1	Mechanical data	14
6.2.2	Pneumatic data	16
6.2.3	Electrical data	16
7	ASSEMBLY AND INSTALLATION	17
7.1	Safety instructions	17
7.2	Pneumatic installation	18
7.3	Electrical installation	18
7.4	Assembling and installing the multiway valve	19
7.4.1	Housing with welded connections	19
7.4.2	Housing without welded connections	19
8	START-UP	20
8.1	Safety instructions	20
9	OPERATION AND FUNCTION	20
9.1	Safety instructions	20
10	MAINTENANCE AND TROUBLESHOOTING	21
10.1	Safety instructions	21

Table of Contents

10.2	Maintenance work	21
10.3	Malfunctions	22
10.4	Recommended auxiliary materials	22
11	SPARE PARTS	22
12	SHUTDOWN	23
12.1	Safety instructions	23
12.2	Removing the multiway valve	23
13	PACKAGING AND TRANSPORT	24
14	STORAGE	24
15	DISPOSAL	24

1 Operating instructions

The operating instructions describe the entire life cycle of the device. Keep these instructions in a location which is easily accessible to every user and make these instructions available to every new owner of the device.

WARNING!

The operating instructions contain important safety information!

Failure to observe these instructions may result in hazardous situations.
The operating instructions must be read and understood.

1.1 Symbols

DANGER!

Warns of an immediate danger!

Failure to observe the warning will result in fatal or serious injuries.

WARNING!

Warns of a potentially hazardous situation!

Failure to observe the warning may result in serious injuries or death!

CAUTION!

Warns of a potential danger!

Failure to observe these instructions may result in moderate or minor injuries.

NOTE!

Warns of damage!

Failure to observe these instructions may result in damage to the device or the system.



Important additional information, tips and recommendations.

Refers to information in these operating instructions or in other documentation.

→ Designates a section which you must carry out.

2 Intended use

WARNING!

General hazard information

Unauthorised use of the device may be hazardous to persons, systems in the vicinity and the environment.

To use the device, observe the authorized data, operating instructions and application areas specified in the contract documents and in the operating instructions!

The aseptic multiway valve system Type 2034, referred to below as multiway valve only,

- is designed for use with ultra-pure, sterile, aggressive or abrasive media which will not attack the housing or the seal material.
Observe the maximum pressure range on the type label!
- may be used only in conjunction with third-party devices and components recommended or approved by Bürkert.
- May be used only as intended.
- Prerequisites for safe and trouble-free operation are correct transportation, correct storage and installation as well as careful operation and maintenance.
- Protect device from harmful environmental influences (radiation, air humidity, fumes etc.). Clarify any ambiguities with the relevant sales office.

2.1 Restrictions

NOTE!

Note on property damage:

The exhaust air may be contaminated by lubricants in the actuator.

If exporting the system/device, observe any existing restrictions (if applicable).

Explosion protection approval

The explosion protection approval is only valid if you use the modules and components authorised by Bürkert as described in these operating instructions.

The electronic modules may be used only in combination with the pneumatic valve types released by Bürkert, otherwise the explosion protection approval will expire!

In the event of unauthorised changes to the system, modules or components, the explosion protection approval will also expire.

3 Basic safety instructions

These safety instructions do not make allowance for any

- eventualities and events which may occur during installation, operation and maintenance of the devices.
- local safety regulations – the operator is responsible for observing these regulations, also in relation to the installation personnel.

-



DANGER!

Danger from high pressure!

Before loosening lines and valves, turn off the pressure and vent the lines!

Danger due to electric voltage!

Before reaching into the device or the system, switch off the power supply (if on) and secure it against reactivation!

Observe applicable accident prevention and safety regulations for electrical equipment!

Risk of burns/fire due to hot device surface if device operated continuously!

Keep the device away from highly flammable substances and media and do not touch with bare hands!

General hazardous situations!

To prevent injuries, ensure that:

- the system cannot be activated unintentionally.
- installation and maintenance work is carried out by authorised technicians only and with the appropriate tools.
- the process is restarted in a defined or controlled manner after an interruption in the power supply or pneumatic supply.
- the device is operated only when in perfect working order and in consideration of the operating instructions.
- the general rules of technology apply to application planning and operation of the device.



WARNING!

Danger due to loud noises.

Depending on the operating conditions, the device may generate loud noises. Detailed information on the likelihood of loud noises is available from the relevant sales office.

→ Wear hearing protection when in the vicinity of the device.

CAUTION!
Medium will escape if the diaphragm is worn

- Regularly check relief bore for escaping medium.
- If medium is escaping from the relief bore, change the diaphragm (see chapter Maintenance work).
- If media is hazardous, protect the area around the discharge point from hazards

NOTE!
Electrostatic sensitive components / modules

The device may contain electronic components which react sensitively to electrostatic discharge (ESD). Contact with electrostatically charged persons or objects is hazardous to these components. In the worst case scenario, they will be destroyed immediately or will fail after start-up

Observe the requirements in accordance with EN 61340-5-1 to minimise or avoid the possibility of damage caused by a sudden electrostatic discharge!

Ensure that you do not touch the electronic components when the power supply voltage is applied!



The device was developed with due consideration given to the accepted safety rules and is state-of-the-art. Nevertheless, dangerous situations may occur. Operate the device only when it is in perfect condition and in accordance with the operating instructions. Non-observance of these instructions and unauthorised tampering with the device will release us from any liability and also invalidate the warranty covering the accessories!

- The medium connections of the system may only be fed with media which have been approved as flow media in chapter 5.1.
- Do not place the housing under mechanical stress (e.g. by placing objects on it or standing on it).
- Do not make any external alterations to the device housings. Do not paint housing parts or screws!
- The actuator housing must not be opened. If opened, there is a risk of injury due to the tensioned spring inside.
- Observe the plant-specific safety regulations for application planning and operation.
- If required, transport, install and remove heavy device only with the help of a second person, using suitable tools.

4 General information

4.1 Contact address

Bürkert Fluid Control Systems
Sales Center
Christian-Bürkert-Straße 13-17
D-74653 Ingelfingen

Tel. + 49 (0) 7940 – 10 91 111
Fax + 49 (0) 7940 – 10 91 448
Email: info@de.buerkert.com
www.buerkert.de

4.2 Warranty

A precondition for the warranty is that the multiway valve is used as intended in consideration of the specified operating conditions.



The warranty covers only freedom from defects of the multiway valve Type 2034 and its components.

No liability is accepted for any kind of consequential damage which could occur due to a failure or malfunction of the device.

4.3 Information on the Internet

Operating instructions and data sheets on the actuator types 2103, 2031, 2063, 3233, 2933, 2973, 3323, 3363 as well as the suitable control units 8690 to 8697, can be found on the Internet at: www.buerkert.de or as a direct link via the QR-Codes in section 5.3.

5 System description

5.1 Intended application area

The multiway valve is designed for use with ultra-pure, sterile, aggressive or abrasive media which will not attack the housing or the seal material.

Observe the maximum pressure range on the system type label!

5.2 General description

The multiway valve consists of:

- Valve body
- Diaphragm(s) Type 2031
- Actuator(s) Type 2103(AP09), 2031(AP2030), 2063(AP2063), 3233(AM3232), 2933(AM293x), 2973(AM297x), 3323(AE33S), 3363(AE33R)

The following control units can also be installed depending on the configuration

- Type 8690, 8697 Pneumatic control unit
- Type 8691, 8695 Control head
- Type 8692, 8694, 8696 Position controller
- Type 8693 Process controller



*A detailed description of the installed actuators and control systems can be found on the **dimensional drawing** and our homepage www.buerkert.de under the respective device types.*

5.2.1 Label information

System type label:

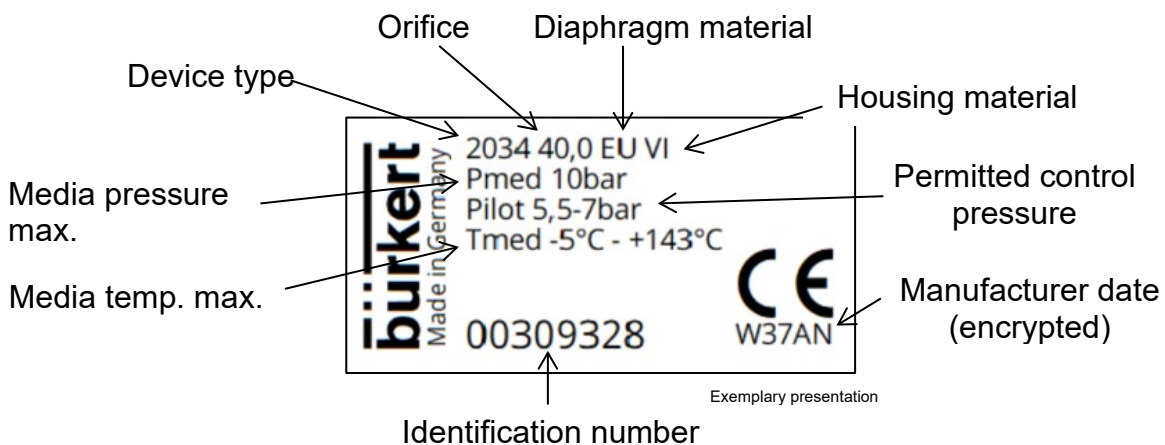

Actuator label example:

Actuator type

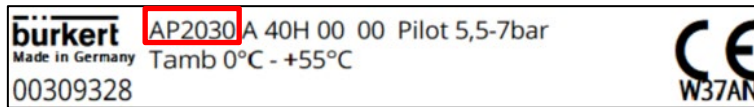

Exemplary presentation

Automation unit label:

Automation unit type



Exemplary presentation

5.3 Operating instructions actuator; automation unit

Operating instructions of respective device types can be found on our homepage

www.buerkert.com.

Please refer to the dimensional drawing for the actuator types or automation units that belong to your system or read the type information directly on the label of the installed actuator or automation unit (see chapter 5.2.1). In the overview below you will find a list of all possible installed device types.

5.3.1 Actuator

Type	Presentation	QR-Code
Type 2103 Type AP09		
Type 2031 Type AP2030		
Type 2063 Type AP2063		
Type 3233 Type AM3232		
Type 2933 Type AM293x		

<p>Type 2973 Type AM297x</p>		
<p>Type 3323 Type AE33S</p>		
<p>Type 3363 Type AE33R</p>		

5.3.2 Automation unit for pneumatic actuators

type	presentation	QR-Code
<p>Type 8690</p>		
<p>Type 8691</p>		
<p>Type 8692</p>		

Type 8693		
Type 8694		
Type 8695		
Type 8696		
Type 8697		

5.4 Functions

The multiway valve is designed for the distribution, collection, blocking and releasing of product and cleaning media.

6 Technical data

6.1 Operating conditions



Protect this device from UV radiation and from the effects of weather if used outside.



WARNING!

If laminated EPDM/adv. PTFE diaphragms are used, the max. media temperature is +90°C. These diaphragms have not been approved for steam.



Permitted operating conditions:

- See type labels on the multiway valve and on the components used.
- For further specifications see operating instructions of the types and components used (compare section 5.3)

6.2 General technical data

6.2.1 Mechanical data

Housing materials (see system type label)			
1.4435	VS	Forged stainless steel 1.4435 according to BN2 DIN EN 10222-5, F316L according to ASTM A182/182m and 316L according to ASME BPE	
Diaphragm materials (see system type label, diaphragms)			
EPDM	AB	E01/E02	Ethylene-propylene-diene rubber
EPDM	AD	E03	Ethylene-propylene-diene rubber
EPDM/PTFE	EA	L04 (DN08) E02+(P01)*	Ethylene-propylene-diene rubber Polytetrafluoroethylene
EPDM/advanced PTFE	EU	L05 (DN08) E02+P02	Ethylene-propylene-diene rubber Polytetrafluoroethylene
EPDM/GYLON®	ER	L06	Ethylene-propylene-diene rubber Polytetrafluoroethylene
FKM	FF	F01	Fluoroelastomer
FKM	FF	F02	Fluoroelastomer

Actuators (see system dimensional drawing, actuator type label)	
Type 2103 / AP09	PPS (polyphenylene sulphide) + VA (stainless steel)
Type 2031 / AP2030	PPS (polyphenylene sulphide) or PA (polyamide)
Type 2063 / AP2063	VA (stainless steel)
Type 3233 / AM3232	Attachment + handwheel PPS (polyphenylene sulphide) or Attachment VA + handwheel PPS (polyphenylene sulphide)
Type 2933 / AM293x	Attachment + handwheel PPS (polyphenylene sulphide) or Attachment VA + handwheel PPS (polyphenylene sulphide)
Type 2973 / AM297x	Attachment VA + handwheel PPS (polyphenylene sulphide)
Type 3323 / AE33S	Attachment VA + aluminium (powder-coated) + PPS (polyphenylene sulphide)
Type 3363 / AE33R	Attachment VA + aluminium (powder-coated) + PPS (polyphenylene sulphide)
Control units (see system dimensional drawing, control unit type label)	
Type 8690	PPS (polyphenylene sulphide) + VA (stainless steel)
Type 8691	PPS (polyphenylene sulphide) + VA (stainless steel)
Type 8692	PPS (polyphenylene sulphide) + VA (stainless steel)
Type 8693	PPS (polyphenylene sulphide) + VA (stainless steel)
Type 8694	PPS (polyphenylene sulphide) + VA (stainless steel)
Type 8695	PPS (polyphenylene sulphide) + VA (stainless steel)
Type 8696	PPS (polyphenylene sulphide) + VA (stainless steel)
Type 8697	PPS (polyphenylene sulphide) + VA (stainless steel)

*Material code not indicated

6.2.2 Pneumatic data

Information on the control medium:

- See type labels on the multiway valve and on the components used.
- For further specifications see operating instructions of the types and components used (compare section 5.3).
- For information on the pilot air ports see operating instructions of the types and components used (compare section 5.3)

6.2.3 Electrical data

If electrical components have been installed - information on electrical data:

- See type labels on the components used.
- For further specifications see operating instructions of the types and components used (compare section 5.3) or other supplied documentation.

7 Assembly and installation

7.1 Safety instructions

DANGER!

Risk of injury from high pressure in the system!

Before loosening lines and valves, turn off the pressure and vent the lines!

Risk of injury due to electric shock!

Before reaching into the device or the system, switch off the power supply and secure it against reactivation!

Observe applicable accident prevention and safety regulations for electrical equipment!

WARNING!

Risk of injury due to improper installation!

Installation may be carried out by authorised technicians only and with the appropriate tools!

Risk of injury due to unintentional activation of the system and uncontrolled restart!

Secure system against unintentional activation.
Following installation, ensure a controlled restart!

NOTE!

When installing the device in the plant, observe the following:

The device and the relief bore must be accessible for monitoring and for maintenance work.

7.2 Pneumatic installation

DANGER!

Risk of injury from high pressure in the system!

Before loosening lines and valves, turn off the pressure and vent the lines!

7.3 Electrical installation

DANGER!

Risk of injury due to electric shock!

Before reaching into the device or the system, switch off the power supply and secure it against reactivation!

Observe applicable accident prevention and safety regulations for electrical equipment!

7.4 Assembling and installing the multiway valve

7.4.1 Housing with welded connections

Procedure:



For information on installing/removing the actuators from the housing, see operating instructions of the types and components used (compare section 5.3).

- Identify installation position of the actuators and other components mounted directly on the housing and on the components.
- Remove actuators together with diaphragms and, if required, feedback indicators or the like and, if required, other components mounted directly on the housing (unless the factory has already removed them before delivery).
- Make welded connections according to the designated installation position (in doing so, observe drainage direction). The preferred installation position can be found in the supplied dimensional drawing.
- Provide suitable support according to the weight (see dimensional drawing) of the multiway valve.
- Assembly of the components. Ensure components are in the correct position (see also dimensional drawing and the labels which were affixed beforehand).
- Make pneumatic and electrical connections (if available).
- Following assembly, the multiway valve is ready for operation.

7.4.2 Housing without welded connections

Procedure:



For information on installation/removal see operating instructions of the types and components used (compare section 5.3), as well as the associated dimensional drawing.

- Connect valve body to the pipeline system via the specified connections using the required components.
- Make connections according to the designated installation position (in doing so, observe drainage direction). The preferred installation position can be found in the supplied dimensional drawing.
- Ensure that the multiway valve is suitably supported.
- Make pneumatic and electrical connections (if available).
- Following assembly, the multiway valve is ready for operation.

8 Start-up

8.1 Safety instructions

WARNING!

Risk of injury due to improper operation!

Improper operation may result in injuries as well as damage to the device and its environment!

Before start-up, ensure that the operating personnel are aware of and have completely understood the contents of the operating instructions.

Observe the safety instructions and intended use.

Only adequately trained personnel may start up the system/device.

Before starting up the device, check that the multiway valve has been correctly installed and check the applied pressures and voltages (see also chapter 6 and chapter 7).

9 Operation and function



See operating instructions of the types and components used (compare section 5.2), as well as the associated dimensional drawing.

9.1 Safety instructions

WARNING!

Risk of injury due to improper operation!

Improper operation may result in injuries as well as damage to the device and its environment!

The operating personnel must know and have understood the contents of the operating instructions.

Observe the safety instructions and intended use.

Only adequately trained personnel may operate the equipment/the device.

10 Maintenance and troubleshooting

10.1 Safety instructions

DANGER!

Risk of injury from high pressure in the system!

Before loosening lines and valves, turn off the pressure and vent the lines!

Risk of injury due to electric shock!

Before reaching into the device or the system, switch off the power supply and secure it against reactivation!

Observe applicable accident prevention and safety regulations for electrical equipment!

WARNING!

Risk of injury due to improper maintenance work!

Maintenance may be carried out by authorised technicians only and with the appropriate tools!

If the multiway valve is used in a potentially explosive environment, maintenance may be carried out by authorised technicians only, who have been trained to work in a potentially explosive environment, and with the appropriate tools!

Risk of injury due to unintentional activation of the system and uncontrolled restart!

Secure system against unintentional activation.

10.2 Maintenance work

The actuators and control units of the multiway valve used are maintenance-free if they are used according to these operating instructions.

Parts which are subject to natural wear are:

- Diaphragms
- Seals

They must be serviced on a regular basis.

If there is a leak, replace the respective wearing part with a corresponding spare part.



For further information on maintenance see operating instructions of the types and components used (compare section 5.3).

10.3 Malfunctions



For information on malfunctions see operating instructions of the types and components used (compare section 5.3).

10.4 Recommended auxiliary materials

for operation, maintenance and repair:



For information on recommended auxiliary materials see operating instructions of the types and components used (compare section 5.3)

11 Spare parts



WARNING!

Risk of injury when opening the actuator housings!

The actuators contain tensioned springs. When the housing is opened, springs will jump out and may cause injuries!

- Actuator housings must not be opened!



CAUTION!

Risk of injury and/or damage due to use of incorrect parts!

Incorrect accessories and unsuitable spare parts may cause injuries and damage to the device and its environment

Use only original accessories and original spare parts from Bürkert!

No spare parts have been defined for the multiway valve.

If spare parts are required, they can be purchased via the Bürkert sales office (see also section 4.1).

12 Shutdown

12.1 Safety instructions

DANGER!

Risk of injury from high pressure in the system!

Before loosening lines and valves, turn off the pressure and vent the lines!

Risk of injury due to electric shock!

Before reaching into the device or the system, switch off the power supply and secure it against reactivation!

Observe applicable accident prevention and safety regulations for electrical equipment!

WARNING!

Risk of injury due to improper removal!

Removal may be carried out by authorised technicians only and with the appropriate tools!

If the multiway valve is used in a potentially explosive environment, maintenance may be carried out by authorised technicians only, who have been trained to work in a potentially explosive environment, and with the appropriate tools!

Risk of injury due to unintentional activation of the system and uncontrolled restart!

Secure system against unintentional activation.

Following assembly, ensure a controlled restart!

12.2 Removing the multiway valve

Procedure:



For information on removing the actuators from the housing, see operating instructions of the types and components used (compare section 5.3).

13 Packaging and transport

NOTE!

Transport damage!

Inadequately protected devices may be damaged during transportation.

- Protect the device from moisture and dirt in shock-resistant packaging during transportation.
- Avoid exceeding or dropping below the permitted storage temperature.
- Protect the electrical interfaces of the coil and the pneumatic connections from damage by placing protective caps on them.

14 Storage

NOTE!

Storage damage!

Incorrect storage may damage the device.

- Store device in a dry and dust-free environment
- **Permitted storage temperatures:** -20 ... +65 °C.

For prolonged storage slacken the housing screws to prevent the diaphragms from becoming deformed.

15 Disposal

NOTE!

Damage to the environment caused by device components contaminated with media!

- Observe applicable disposal and environmental regulations!
- Observe national waste disposal regulations!

→ Dispose of the device and the packaging in an environmentally friendly manner.