

Process valves of the CLASSIC, ELEMENT, EVA series and valves with stainless steel actuator housing

Prozessventile der Reihen CLASSIC, ELEMENT, EVA sowie Ventile mit Antriebsgehäuse aus Edelstahl

Vannes de process des séries CLASSIC, ELEMENT, EVA ainsi que des vannes avec corps d'actionneur en acier inoxydable

Valve seat

Ventilsitz

Siège de vanne



Replacement Instructions

Austauschanleitung

Instructions de remplacement

## Table of contents

1	Replacement Instructions .....	2
2	Unscrew actuator from the valve body.....	2
3	Replace valve seat.....	5
4	Screw the actuator to the valve body.....	6
5	Execute X.TUNE or teach function.....	6

# 1 Replacement Instructions

This instruction describes the procedure for changing the valve seat.

### Important safety information.

- ▶ The instruction must be read and understood.

The detailed description of your device can be found in the operating instruction at: [www.burkert.com](http://www.burkert.com)

## 1.1 Symbols used



### DANGER

Immediate danger! Serious or fatal injuries.

## NOTE

Warns of damage.



Important tips and recommendations.



Refers to information in these replacement instructions or in other documentation.

- ▶ Designates an instruction for risk prevention.
- Designates a procedure which you must carry out.

# 2 Unscrew actuator from the valve body



### DANGER

Risk of injury due to high pressure and escaping medium.

- ▶ Only work on depressurised systems. Vent and drain the lines.

## NOTE

Damage to the valve seat seal or the seat contour.

- ▶ When removing, the valve must be in the open position.

## 2.1 Valves in the CLASSIC and ELEMENT series and with actuator housing made of stainless steel

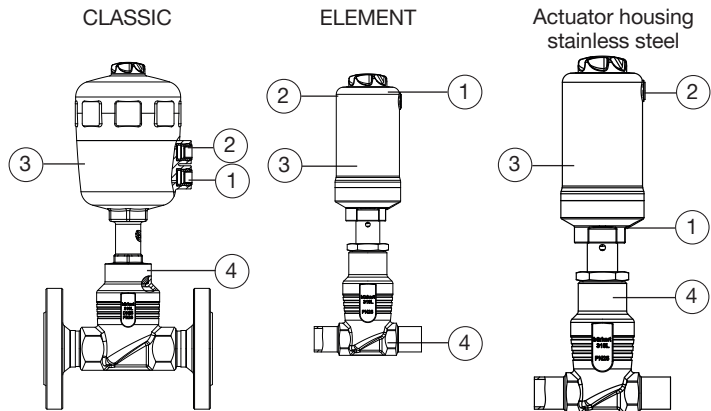

Item	Description
1	Pilot air port 1
2	Pilot air port 2

Item	Description
3	Actuator
4	Valve body

- CFA and I: Pressurise pilot air port 1 with compressed air (5 bar).
- Apply a suitable open-end wrench and unscrew the valve body.

## 2.2 Valves of the EVA series

### 2.2.1 Open valve electrically

Precondition: Device is in the MANUAL operating state.

Devices with display module:

- Press the upper navigation button to open the valve.
- Switch off the supply voltage. Wait until the LED ring goes out.
- Apply a suitable open-end wrench and unscrew the valve body.

Devices without display module:

- Turn the blind cover and remove it.
- Press the OPEN button until the valve is completely open.
- Switch off the supply voltage. Wait until the LED ring goes out.
- Apply a suitable open-end wrench and unscrew the valve body.

## 2.2.2 Open valve mechanically

Precondition: Valve currentless.



In the currentless state, the mechanical manual override can be used. Observe the exact description in the respective operating instructions for your device.

- Turn and remove the blind cover or display module.
- Apply light pressure to engage the manual override and turn it anti-clockwise with the 4 mm Allen key until the valve is open.
- Apply a suitable open-end wrench and unscrew the actuator.



For fieldbus variants, the fieldbus module must be removed. Observe the exact description in the respective operating instructions for your device.

## 2.3 Valves CLASSIC and valves with actuator housing made of stainless steel with control unit

- CFA: Loosen the external tubing on pilot air port 1 of the valve.
- CFA and I: Pressurise pilot air port 1 of the actuator with compressed air (5 bar).
- Apply a suitable open-end wrench and unscrew the valve body.

## 2.4 ELEMENT valves with control unit

Precondition: Control unit is in the MANUAL operating state (MANU).

Manually move the valve to the open position:

### a) Control head

- Control head with position feedback (without built-in pilot valve): pressurise with compressed air (5 bar) at port 1 of the control unit.
- Control head with pneumatic control unit (with built-in pilot valve): Pressurise pilot air port 1 of the control unit with compressed air (5 bar) and operate the red hand lever on the pilot valve.
- Positioner or process controller: Switch the control unit to the MANUAL operating state and move the valve manually to the open position.
- Apply a suitable open-end wrench and unscrew the valve body.

### b) Side control

- Remove the compressed air supply from the supply pressure connection of position sensor 1 and pressurise manually with 5 bar.
- Apply a suitable open-end wrench and unscrew the valve body.



The exact procedure for manually opening the valve depends on the type of control unit. For further informations read the operating instructions of the control unit.

### 3 Replace valve seat



The assembly tool is not included in the valve set and can be ordered separately. The order number can be found in the operating instructions for your valve at [www.burkert.com](http://www.burkert.com)

- Screw the appropriate tool insert into the assembly tool.
- Unscrew the old valve seat using the assembly tool and a wrench.
- Clean the threads and sealing surfaces in the valve body using compressed air.
- Attach a new valve seat to the assembly tool.

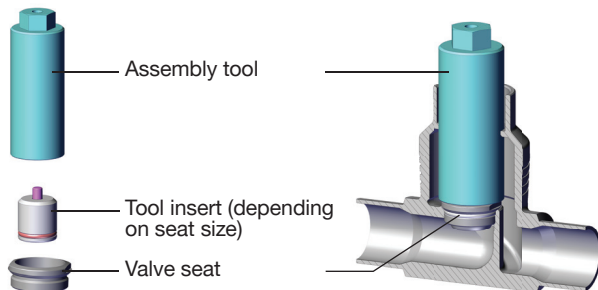

#### DANGER

##### Danger due to lubricant.

Lubricant may contaminate the medium. There is a risk of explosion in oxygen applications.

- ▶ Only use lubricants that are suitable for the application. Contact the Bürkert sales department with any questions.
- ▶ Observe the lubricant manufacturer's data sheet specifications.

- Apply lubricant to the valve seat thread.
- Screw the attached valve seat into the thread of the valve body manually using the assembly tool.
- Tighten the valve seat using a torque wrench. Observe the tightening torques in the following table.

##### Tightening torques for valve seat assembly:

Fitting		Tightening torques		Tolerance [Nm]
Seat size	Valve body port size DN	Uncoated seats [Nm]	Coated seats [Nm]	
4-15	10/15	25	20	+3
20	20	35	28	+3
25	25	50	40	+5

32	32	80	65	+5
40	40	100	85	+8
50	50	120	120	+8
65	65	150	150	+10
80	80	180	180	+10
100	100	220	220	+10

#### 4 Screw the actuator to the valve body

- Check seal between actuator and valve body and replace if necessary.
- Apply lubricant to the thread between actuator and valve body.

#### NOTE

**Damage to the valve seat seal or the seat contour.**

- ▶ During assembly, the valve must be in the open position.

- Move the valve to the open position.
- Screw actuator into the valve body. Observe the tightening torques in the following table.

Tightening torques for valve body:

DN	Tightening torque
15	45 ±3 Nm
20	50 ±3 Nm
25	60 ±3 Nm
32	65 ±3 Nm
40	65 ±3 Nm

DN	Tightening torque
50	70 ±3 Nm
65	100 ±3 Nm
80	120 ±5 Nm
100	150 ±5 Nm

#### 5 Execute X.TUNE or teach function

- For valves EVA and valves with control unit after mounting the actuator, execute X.TUNE or teach function to ensure that the valve closes tightly.



For detailed information on X.TUNE or the teach function, refer to the respective operating instructions for your control unit.

Bürkert Fluid Control Systems  
Sales Center  
Christian-Bürkert-Str. 13-17  
D-74653 Ingelfingen  
Tel. + 49 (0) 7940 - 10-91 111  
Fax + 49 (0) 7940 - 10-91 448  
E-mail: [info@burkert.com](mailto:info@burkert.com)



International address  
[www.burkert.com](http://www.burkert.com)

Manuals and data sheets on the Internet: [www.burkert.com](http://www.burkert.com)  
Bedienungsanleitungen und Datenblätter im Internet: [www.buerkert.de](http://www.buerkert.de)  
Manuels d'utilisation et fiches techniques sur Internet : [www.burkert.fr](http://www.burkert.fr)

© Bürkert Werke GmbH & Co. KG, 2022  
Operating Instructions 2202/00\_EU-ML\_00815421 / Original DE

[www.burkert.com](http://www.burkert.com)