

Typ FULLBORE S055/S051/S054

SENSORS

Installation manual

DE

Ausführliche Informationen finden Sie in der Bedienungsanleitung
unter der Internetadresse:
country.burkert.com > S055_S051_S054
oder
scannen Sie folgenden QR-Code ein:



EN

Detailed information can be found in the operating instructions
at the Internet address:
country.burkert.com > S055_S051_S054
or
scan the following QR code:



FR

Vous trouverez des informations détaillées dans le mode d'emploi
à l'adresse Internet suivante :
country.burkert.com > S055_S051_S054
ou
scannez le code QR suivant :



INDEX

INTRODUCTION	2
START UP AND MAINTENANCE OF THE INSTRUMENTS	2
SAFETY	3
GENERAL INFORMATION ON THE SENSORS INSTALLATION	3
ELECTRICAL CONNECTIONS OF SENSOR TO TRANSMITTER	6
GROUNDING INSTRUCTIONS	7
TORQUES (NM) FOR SENSOR BOLTS (FLANGED & WAFER)	8

INTRODUCTION

- This manual is integral part of the product. Read carefully the instructions contained since it contains important indications for the safety of use and of maintenance.
- The technical information and the relative products of this manual could be modified without any previous notice.
- The flowmeter must be used for the use it has been built for. The improper use, possible tampering of the instrument or parts of it and substitutions of any components not original, makes the warranty to decay automatically.
- The manufacturer is considered responsible only if the instrument is used in its original configuration and setting.
- The flowmeter makes measures of liquids with conductivity greater than $5\mu\text{S}/\text{cm}$; it consists of a sensor (described in this manual) and a converter, for it see the manual provided.
- If the sensor is supplied in compact version to the converter, consider the operating temperatures more restrictive, otherwise refer to the respective manuals.
- When transporting, unpacking and handling the flowmeter, be careful and care.
- In the case of prolonged storage and of transport, use and store in the original container in a dry place, do not place more than 3 packs one above the other. It is possible pallets storage and transport (in case of wooden crates do not place one above the other).
- For the cleaning of the device use only a damp cloth, and for the maintenance/repairs, contact the customer service.
- For the disposal of the device and of the packaging make strict reference to the regulations.
- It is forbidden the reproduction of the present manual and of possible software supplied with the instrument.

START UP AND MAINTENANCE OF THE INSTRUMENTS

- Before starting up the instrument, always make a secure connection to ground as suitable to page 6.
- Verify periodically: the cables integrity, the tightening of the sealing elements (cable glands, covers, etc.), the mechanical fixing of the instrument on the pipe or on the wall.

SAFETY



Before using the instrument, always make a secure connection to the ground



Avoid any attempt to repair the instrument. If the instrument is not functioning properly, please call the nearest assistance service



Pay maximum attention during the operations



ATTENTION !!



DANGER !!!

GENERAL INFORMATION ON THE SENSORS INSTALLATION

Flow direction

Before installing the sensor check the direction of the liquid in the piping.

The sign of the flow rate is positive, when the flow direction is from - to + as printed on the tag plate. If the device is mounted in the reverse normal flow direction, the sign of the flow rate can be corrected by changing the sign of the coefficient KA.

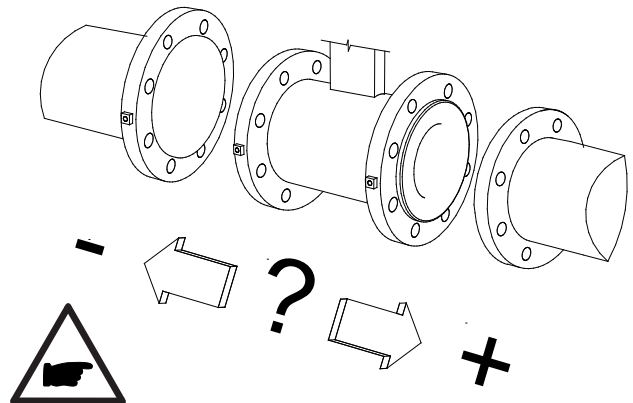

Installation (Method recommended for ALL THE SENSOR WITH EYEBOLT)

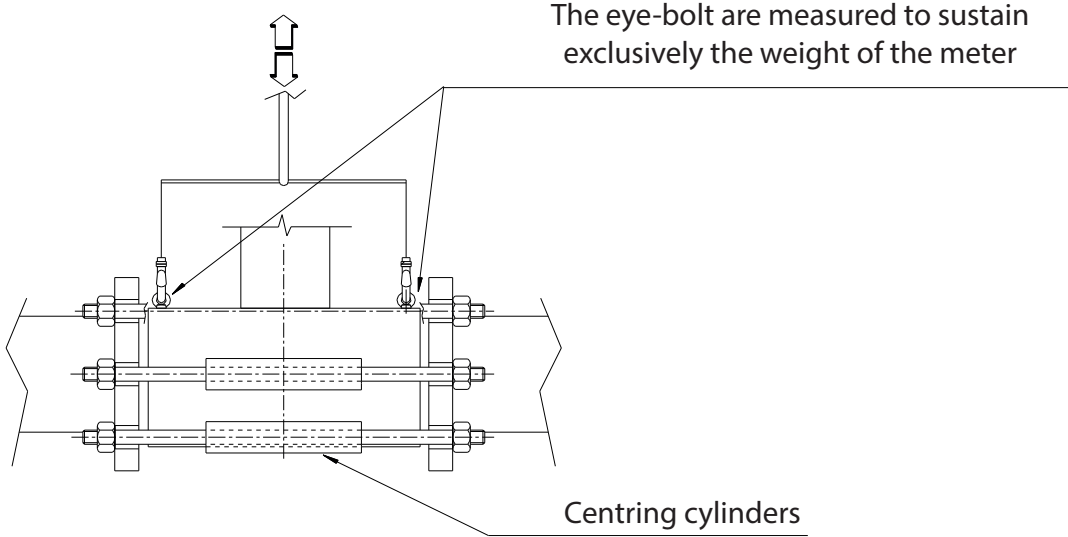

N.B.: For sensor S054 we recommed the use of centring cylinders

Shrewdness and precautions

NO

YES

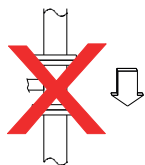

For vertical installations with descending flow direction contact the manufacturer

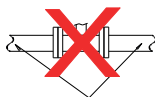

LONG PIPE

Avoid the installation of the sensor in a long pipe, without any support of the same



Avoid operating when the pipe is partially empty

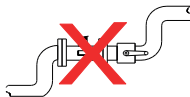

Avoid the installation next to bows in pipes and respect min. inlet and outlet sections



Avoid the approach of the flange and counter flange using the closing force of the nuts

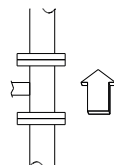

For vertical installations is preferable an ascending flow



ANTI VIBRATION JOINTS

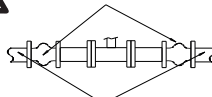

LONG PIPE

For installations on long pipes, please use the anti vibration joints

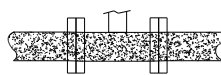

During operation, the pipe must be either completely full of liquid, or completely empty

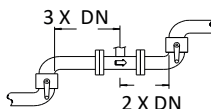

Install the sensor at a min. distance to bows in pipes and hydraulic accessories

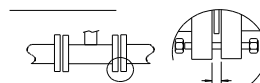

GASKET THICKNESS + 4mm

Before tightening the nuts, place both the flanges of pipe and device as near together as possible.

OPERATING TEMPERATURES

	EBONITE LINING				PP LINING				PTFE LINING			
	Liquid Temp.		Ambient Temp.		Liquid Temp.		Ambient Temp.		Liquid Temp.		Ambient Temp.	
	Min.	Max.	Min.	Max.	Min.	Max.	Min.	Max.	Min.	Max.	Min.	Max.
°C	0	80	-5	60	0	60	0	60	-20	130	-10	60
°F	30	176	23	140	32	140	32	140	-4	266	14	140

ELECTRICAL CONNECTIONS OF SENSOR TO TRANSMITTER (Connections to transmitter: see related manual)

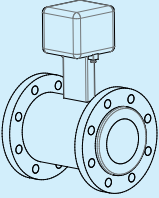
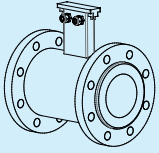
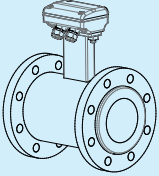
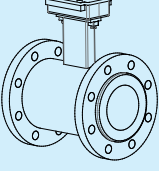
	VERSION	SUITABLE FOR	SENSOR'S CONNECTION
	COMPACT	ALL SENSORS MODEL	NO CONNECTIONS
	SEPARATE WITHOUT JUNCTIONS-BOX	STAINLESS STEEL MODEL	NO CONNECTIONS REQUIRED (CABLE ALREADY CONNECTED AND POTTED)
	SEPARATE WITH OR WITHOUT JUNCTIONS-BOX	ALL CARBON STEEL MODELS	NO CONNECTIONS REQUIRED (CABLE ALREADY CONNECTED AND POTTED)
	SEPARATE WITH PREAMPLIFIER	ALL SENSORS MODEL	SEE BELOW

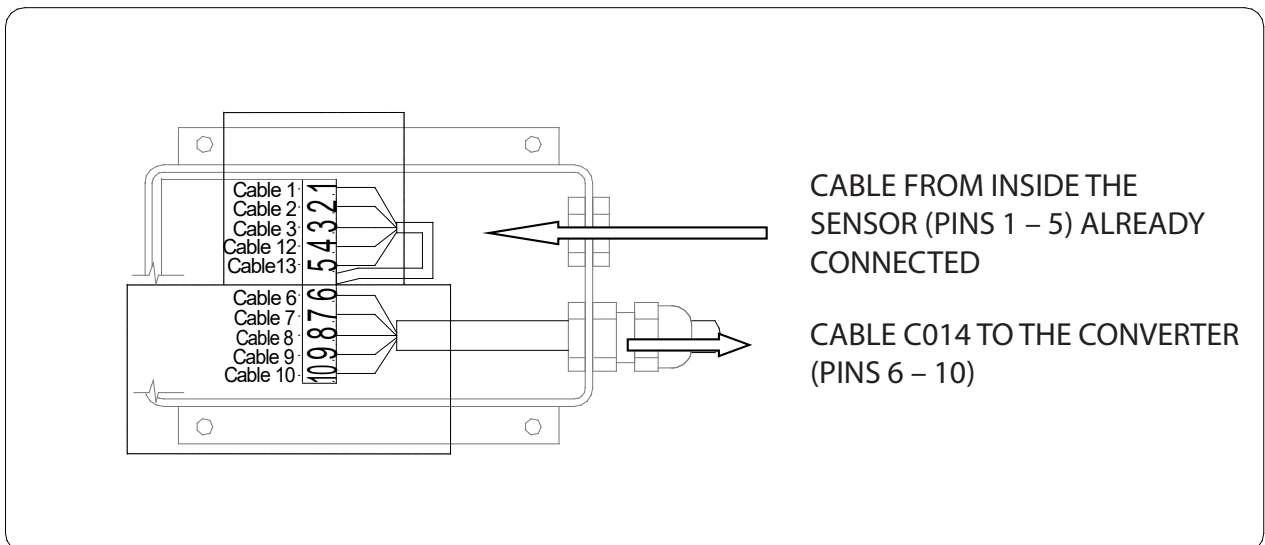

GROUNDING INSRUCTIONS



For correct operation of the meter, it is **NECESSARY** that the sensor and the liquid are equipotential, so **ALWAYS** connect the sensor and converter to ground:

○ GROUNDING WITH METALLIC PIPE

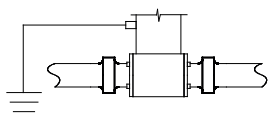

Sensors with ground socket on the connection box

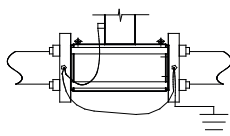

Wafer sensors

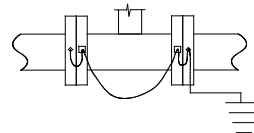

Flanged sensors

○ GROUNDING WITH INSULATING PIPE

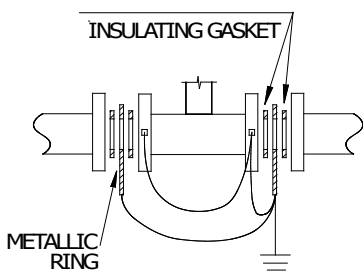

If the sensor has to be mounted on a pipe made of an insulating material is necessary:

- Install two metallic ring between the sensor flanges and the counter flanges of the pipe line or:
- Use a sensor with the additional grounding electrode

○ GROUNDING WHEN THERE IS A CATHODIC PROTECTION OVER THE PIPE

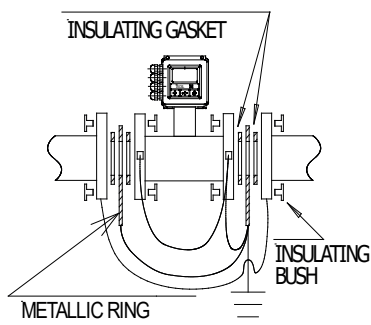

If the sensor must be install in the piping with a chatode protection, is necessary:

- using insulating bushes to isolate the bolts
- Grounding metallic rings should be provided to ground the liquid using insulating gasket between the rings
- **IMPORTANT :**
The ripple of DC power source used for cathodic protection shall be = 0



TORQUES (NM) FOR SENSOR BOLTS (FLANGED & WAFER)

OPERATIVE PRESSURE										
Kpa	1000		1600			2500		4000		6400
psi	140		260			350		600		1000
DN	PTFE	EBON.	PTFE	EBON.	PP	PTFE	EBON.	PTFE	EBON.	EBON.
25			25 (21)		19	25		25 [32]		39 [32]
32			43 (26)		28	43		43 [40]		53 [40]
40			53 (32)		36	53		53 [63]		72 [63]
50			68 (60)		52	68		68 [35]		81 [35]
65			90 (78)		75	45		45 [53]		58 [53]
80			53 (89)		41	53		53 [68]		62 [68]
100			59 (70)		56	83		83 [94]		87 [94]
125			77 (94)		71	112		112 [130]		148 [130]
150			108 (106)		106	135		135 [113]		217 [113]
200	148	432	99 (148)	288 (433)		134	391	178 [178]	520 [519]	816 [519]
250	123	359	140 (156)	408 (455)		204	595	267 [185]	780 [540]	1124 [540]
300	142	415	175 (234)	510 (683)		201	588	278 [275]	812 [803]	1108 [803]
350	172	502	205 (325)	598 (946)		324	945	422 [318]	1231 [927]	1684 [927]
400	217	632	282 (317)	821 (911)		426	1243	619 [411]	1805 [1198]	2180 [1198]
450	194	564	281 (336)	981 (926)				[398]	[1161]	
500	224	652	382 (317)	1113 (924)				[465]	[1356]	
550			(379)	(1105)				[608]	[1772]	
600	323	942	568 (463)	1658 (1350)				[774]	[2258]	
650			(429)	(1251)				[753]	[2195]	
700	356	1040	421 (503)	1230 (1468)				[947]	[2761]	
750			(451)	(1315)				[1105]	[3223]	

MAN 1000497776 EN Version: A Status: RL (released | freigegeben) printed: 07.06.2026

800	476	1388	549	1603						
850			(563)	(1642)				[1373]	[4006]	
900	450	1312	519 (618)	1515 (1803)				[1408]	[4106]	
1000	582	1699	721 (736)	2105 (2146)				[1598]	[4662]	

- Tighten uniformly in an alternating pattern
- The torque listed in tab are applicable to flanges:
EN1092-1, DIN 2501, BS 4504, ANSI B16.5 , JIS
- Use gaskets acc. to DIN 2690
- For DN > 1000 contact the manufacturer
- (***)= ANSI 150
- [***]= ANSI 300

At the end of its lifetime, this product shall be disposed of in full compliance with the environmental regulations of the state in which it is located.

REVIEW	DATE	DESCRIPTION
MAN_FULLBORE_S055_S020_S054_EN_BU_R06	23/03/2021	GRAPHIC UPDATE AND CONTENT CORRECTIONS

