

We reserve the right to make technical changes without notice.

© Bürkert SAS 2023-2026

Technical documentation 2603/04_GBen_424237579_18014399813615627 / Original EN

Table of contents

1	About this document	6
1.1	Symbols	6
1.2	Terms and abbreviations	7
1.3	Manufacturer	7
2	Safety	8
2.1	Intended use	8
2.2	Safety instructions	8
3	Product description	11
3.1	Product overview	11
3.2	Product identification	12
3.2.1	Type label	12
3.2.2	Calibration label	12
3.2.3	Conformity marking	13
3.2.4	Symbols and markings on device	13
3.3	Display elements	13
3.3.1	Status indicator	13
3.3.2	NAMUR mode	13
3.3.3	Network status indicator	14
3.3.4	Communication indicator	14
3.4	Functionality	15
3.4.1	Service-büS interface	15
3.4.2	Control valve	15
3.4.3	Memory card	15
4	Technical data	17
4.1	Standards and directives	17
4.2	Operating conditions	17
4.3	Medium data	17
4.4	Electrical data	18
4.5	Communication	19
4.5.1	Industrial Ethernet: EtherCAT	19
4.5.2	Industrial Ethernet: EtherNet/IP	19
4.5.3	Industrial Ethernet: Modbus TCP	20
4.5.4	Industrial Ethernet: PROFINET IO	20
4.6	Mechanical data	20
5	Medium connection	21
5.1	Possible medium connections	21
5.2	Installation procedure	21
5.2.1	G1/8"-internal-threaded connections	21
5.2.2	NPT1/8"-internal-threaded connections	21
5.2.3	Flange connections	22
5.2.4	Connections with external-threaded vacuum fittings	22
5.2.5	Connections with external-threaded compression fittings	22
5.2.6	Tri-clamp connections	22
6	Electrical connection	23
6.1	Additional documentation	23

6.2	Wire the variant Industrial Ethernet	23
6.3	Change the network parameters	24
6.3.1	Over the product web server	24
6.3.2	Over the Bürkert Communicator software	25
6.4	Connect the functional earth	26
7	Commissioning	27
7.1	Commissioning procedure	27
8	Configuration with Bürkert Communicator	28
8.1	Setting tools	28
8.2	Connect to the Bürkert Communicator	28
8.3	Setting the Industrial Ethernet address	29
8.4	Functions	29
8.4.1	Shut-Off threshold for the valve	29
8.4.2	Cut-Off threshold for actual flow	29
8.5	Change of medium	29
8.6	User-defined adjustment	29
8.7	Zero point adjustment	30
8.8	Set-point value sources and operation modes	30
8.9	Operation modes	31
8.10	Normal operation mode	31
8.10.1	Industrial Ethernet variant	32
8.11	Optimise the closed-loop control parameters	32
8.12	Select the source that gives the set-point value	33
8.13	Set-point values without communication	34
9	Maintenance	35
9.1	Service tasks and intervals	35
9.2	Inspect and clean the stainless steel mesh-filter	35
9.3	Calibration	36
9.4	Replace the memory card	36
10	Troubleshooting	37
10.1	Status indicator is red	37
10.2	Status indicator is orange	37
10.3	Status indicator is yellow	38
10.4	Status indicator is blue	38
10.5	Status indicator is off	38
10.6	Status indicator goes out periodically	38
10.7	Replacement device adopts none of the values from the defective device	39
10.8	Replacement device does not adopt all of the values from the defective device	39
10.9	No mass flow rate	39
10.10	Unstable measured value	40
10.11	Set-point value at 0 %, but medium still flows	40
10.12	Set-point value at 0 %, no mass flow, but a non-zero mass flow rate is measured	40
10.13	Set-point value is not reached	41
10.14	Network status indicator	41
11	Uninstallation	42
11.1	Dismantling	42
12	Spare parts and accessories	43

12.1	Electrical accessories	43
12.2	Compression fittings for a device with G-internal-threaded connections	43
12.3	Additional software	43
13	Logistics	44
<hr/>		
13.1	Transport and storage	44
13.2	Return	44
13.3	Disposal	44

1 About this document

The document is an important part of the product and guides the user to safe installation and operation. The information and instructions in this document are binding for the use of the product.

- ▶ Before using the product for the first time, read and observe the whole safety chapter.
- ▶ Before starting any work on the product, read and observe the respective sections of the document.
- ▶ Keep the document available for reference and give it to the next user.
- ▶ Contact the Bürkert sales office for any questions.



Further information concerning the product at [Products](#).

- ▶ Enter the article number from the type label in the search bar.

The illustrations in these instructions may vary depending on the product variant.

1.1 Symbols



DANGER!

Warns of a danger that leads to death or serious injuries.



WARNING!

Warns of a danger that can lead to death or serious injuries.



CAUTION!

Warns of a danger that can lead to minor injuries.

NOTICE!

Warns of property damage on the product or the installation.



Indicates important additional information, tips and recommendations.



Refers to information in this document or in other documents.

- ▶ Indicates a step to be carried out.

✓ Indicates a result.

Menu Indicates a software user-interface text.

1.2 Terms and abbreviations

The terms and abbreviations are used in this document to refer to following definitions.

Device	Type 8743
MFC	Mass flow controller
bar, bar (g)	Unit for relative pressure
bar abs	Unit for absolute pressure
Ex area	Potentially explosive atmosphere
Ex approval	Approval for potentially explosive atmosphere

1.3 Manufacturer

Bürkert SAS

20, rue du Giessen

67220 TRIEMBACH-AU VAL

FRANCE

The contact addresses are available at [Contact](#).



Need more information or additional products?

► Explore the full range of products on our [eShop](#).

2 Safety

2.1 Intended use

The device MFC is designed to measure and regulate the mass flow rate of clean and dry gases.

The permitted media are listed in [Technical data \[▶ 17\]](#).

Prerequisites for safe and trouble-free operation are proper transport, storage, installation, commissioning, operation and maintenance.

The instructions are part of the device. The device is intended exclusively for use within the scope of these instructions. Uses of the device that are not described in these instructions, the contractual documents or the type label can lead to severe personal injury or death, damage to the device or property and dangers for the surrounding area or the environment.

- ▶ Only trained and qualified personnel may install, operate and maintain the device. See qualification of persons in [Safety instructions \[▶ 8\]](#)
- ▶ Use the device only in conjunction with third-party devices and components recommended and authorized by Bürkert.
- ▶ Use the device only when it is in perfect condition.
- ▶ Only use the device indoors.
- ▶ Only use devices that are approved for this type of potentially explosive atmosphere. These devices are labelled with the ATEX label on the type label. When using, always observe the details on the type label and the instructions for the potentially explosive atmosphere included in the scope of delivery for the device.
- ▶ Do not open the device.
- ▶ Do not use the device in high-vibration areas.

2.2 Safety instructions

Qualification of personnel working with the device

Improper use of the device can lead to serious personal injury or death. To avoid accidents when working with the device, the following minimum requirements must be met:

- ▶ Carry out work on the device within the scope of these instructions in a safety-compliant manner.
- ▶ Detect and avoid dangers when working on the device.
- ▶ Understand the instructions and implement the information contained therein accordingly.

Responsibility of the operator

The operator is responsible for observing the location-specific safety regulations, also in relation to personnel.

- ▶ Observe the general rules of technology.
- ▶ Install the device according to the regulations applicable in the respective country.
- ▶ The operator must make hazards arising from the location of the device avoidable by providing appropriate operating instructions.

Electrostatically sensitive components and assemblies

The device contains electronic components that are susceptible to the effects of electrostatic discharging (ESD). Components that come into contact with electrostatically charged persons or objects are at risk. In the worst case scenario, these components will be destroyed immediately or fail after start-up.

- ▶ Meet the requirements specified by EN 61340-5-1 to minimise or avoid the possibility of damage caused by a sudden electrostatic discharge.
- ▶ Do not touch electronic components when the supply voltage is connected.

Electric shock due to electrical components

Touching live parts can result in severe electric shock. This can lead to serious personal injury or death.

- ▶ Before working on the device or system, switch off the power supply. Secure it against reactivation.
- ▶ Observe any applicable accident prevention and safety regulations for electrical devices.

Changes and other modifications, spare parts and accessories

Changes to the device, incorrect installation or use of non-approved devices or components create hazards that can lead to accidents and injuries.

- ▶ Do not make any changes to the device.
- ▶ Do not mechanically load the device.
- ▶ Observe the operating instructions of the device or component used.
- ▶ Only use the devices in conjunction with devices and components recommended or approved by Bürkert.

Spare parts and accessories that do not meet Bürkert's requirements may impair the operational safety of the device and cause accidents.

- ▶ To ensure operational safety, only use original parts from Bürkert.

Operation only after proper transport, storage, installation, commissioning, or maintenance

Improper transport, storage, installation, commissioning, or maintenance jeopardises the operational safety of the device and can cause accidents. This can lead to serious personal injury or death.

- ▶ Observe all values and limits specified in these instructions to ensure the device's safety and functionality.
- ▶ Only carry out work described in these instructions.
- ▶ Only carry out work using suitable tools.
- ▶ All other work must be carried out by Bürkert only.

Working on the device

Working on the device that has not been powered down, unauthorised switching on or uncontrolled start-up of the system can cause accidents. This can lead to serious personal injury or death.

- ▶ Only work on the device when it is not in use.
- ▶ Ensure that the device or system cannot be switched on unintentionally.

- ▶ Only start the process in a controlled manner following disruptions. Observe sequence:
 1. Apply supply voltage or pneumatic supply.
 2. Charge the device with medium.

Technical limit values and media

Non-compliance with technical limit values or unsuitable media can damage the device and lead to leaks. This can cause accidents and seriously injure or kill people.

- ▶ Comply with limit values. See **Technical data** [▶ 17] and information on the type label.
- ▶ Only feed media into the media ports that are listed in the chapter **Technical data** [▶ 17].
- ▶ Observe the safety data sheet for the media used.

Only use authorised devices in potentially explosive atmospheres

Devices that may be used in potentially explosive atmospheres are labelled with an Ex marking. Additional instructions with Ex labelling are included with these devices.

- ▶ Only use devices that are approved for use in a potentially explosive atmosphere.
- ▶ For use in potentially explosive atmospheres, observe the information on the device.
- ▶ For use in potentially explosive atmospheres, observe the additional instructions with Ex labelling.
- ▶ Do not use devices that do not have this Ex labelling and additional instructions in potentially explosive atmospheres under any circumstances.

Medium under pressure

Medium under pressure can seriously injure people. In the event of overpressure or pressure surges, the device or lines can burst. Pneumatic lines that are defective or not securely fastened can come loose and swing around.

- ▶ Before working on the device or system, switch off the pressure. Vent or empty the lines.
- ▶ Adhere to the permitted pressure ranges of the medium.
- ▶ Comply with the permitted temperature ranges of the medium.

Hot surfaces and fire hazard

The surface of the device can become hot with fast-switching actuators or with hot media.

- ▶ Wear suitable protective gloves.
- ▶ Keep highly flammable substances and media away from the device.

3 Product description

3.1 Product overview

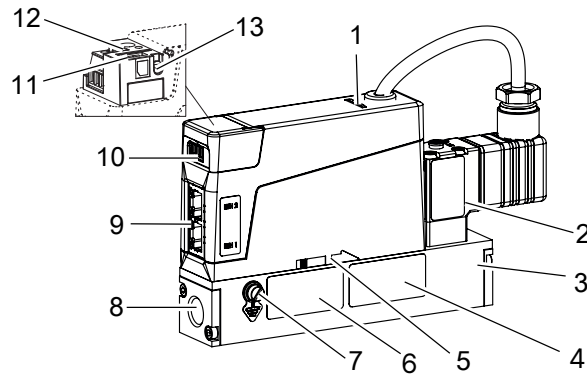

Fig. 1: Example of a variant

1 Status indicator	2 Proportional valve
3 Base block	4 Calibration label
5 Flow direction marking	6 Type label
7 Functional earth connection	8 Medium connection
9 Electrical connection	10 3-pin removable terminal strip
11 bus interface	12 Slot for memory card
13 Communication indicator	

3.2 Product identification

3.2.1 Type label

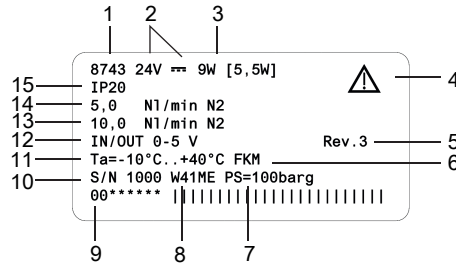

Fig. 2: Example of type label Type 8743

1 Type	2 Operating voltage
3 Power consumption	4 Note: Observe the operating instructions
5 Bürkert internal version	6 Sealing material
7 Burst pressure	8 Manufacture code
9 Article number	10 Serial number
11 Ambient temperature	12 Protocol
13 Nominal mass flow rate (Q nominal), unit and operating gas 2	14 Nominal mass flow rate (Q nominal), unit and operating gas 1
15 Degree of protection	

3.2.2 Calibration label

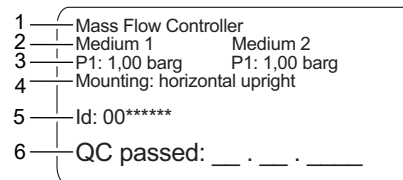

Fig. 3: Example of calibration label

1 Variant	2 Calibration medium
3 Calibration pressure	4 Installation position
5 Article number	6 Calibration date

3.2.3 Conformity marking

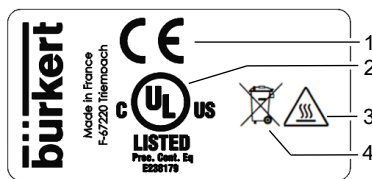

Fig. 4: Conformity label

1 CE marking	2 Certification marking for USA and/or Canada
3 Warning: hot surface	4 Indication for disposal

3.2.4 Symbols and markings on device



Earth terminal



Direct current

DC-B0-58-FF-FF-
FF

Example of marking of the MAC address

ETH1, ETH2

Ethernet connections

3.3 Display elements

3.3.1 Status indicator

The status indicator changes its colour based on the NAMUR recommendation NE 107. Refer to [NAMUR mode \[▶ 13\]](#).

The colour of the status indicator indicates:

- Whether device diagnostics are active or not. Diagnostics are active on the device and cannot be deactivated.
- If diagnostics are active, then the status indicator shows whether diagnostics events have been generated or not. If several diagnostics events have been generated, then the status indicator shows the diagnostics event with the highest priority.

If the status indicator flashes, then the device is selected in a man-machine interface such as the Bürkert Communicator software.

- ▶ To solve a problem indicated by the status indicator, refer to [Troubleshooting \[▶ 37\]](#)

3.3.2 NAMUR mode

The status indicator shows the status of the device and its peripherals, based on NAMUR recommendation 107 (NE 107).

If various alerts are present, the status indicator always shines in the colour of the highest prioritised alert (red = outage = highest priority).

Colour	Colour code	Status signal	Description
Red	5	Failure	Due to a malfunction in the device or its periphery, normal operation is not possible.
Orange	4	Check function	Work is being carried out on the device, which means that normal operation is temporarily not possible.
Yellow	3	Out of specification	The environmental or process conditions for the device are outside the specified range. Internal device diagnosis indicate problems in the device or process characteristics.
blue	2	Maintenance required	The device is in normal operation, although a function is briefly restricted. ▶ Service device
Green	1	Diagnosis active	Device is running faultlessly, diagnosis are active.
White	0	Diagnosis passive	Device is switched on, diagnosis are inactive.

Tab. 1: Status indicator according to NE 107

3.3.3 Network status indicator

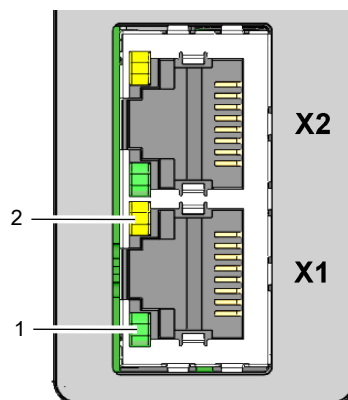

Fig. 5: Location and description of the LED's of an RJ45 socket

1 Link/Act LED (green)	2 Link LED (yellow)
------------------------	---------------------

3.3.4 Communication indicator

This LED shows the status of the communication between the device and the PLC (Programmable Logical Controller).

LED indicator	Description	Meaning
Green	RUN	Connection to the PLC is active.
Red	ERROR	Connection to the PLC is inactive.

Tab. 2: Description of the communication indicator

3.4 Functionality

3.4.1 Service-büS interface

The Service-büS interface is used for short-term servicing of the device with the Bürkert Communicator.

The Bürkert Communicator runs under Windows. Refer to [Connect to the Bürkert Communicator \[▶ 28\]](#)

The USB-büS-Interface set, available as an accessory, is necessary. Refer to [Spare parts and accessories \[▶ 43\]](#)

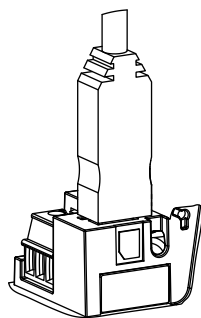

Fig. 6: büS stick, inserted in the related connector of the device

3.4.2 Control valve

The control valve is a direct-acting and normally-closed proportional valve.

The control valve provides the sealing function when the following conditions are met:

- The device is used within the specified pressure range.
- The device is equipped with a valve seat seal that is made of a soft material such as FKM, FFKM or EPDM.



If the valve seat seal is made of a hard material such as PCTFE, then the control valve may not be tight.

Valves with a seat size of 0.05 mm or 0.1 mm have a seat seal made of a hard material.

Unstable measured values may occur. Refer to [Unstable measured value \[▶ 40\]](#)

3.4.3 Memory card



If the memory card is defective or has been lost, contact the Bürkert sales office to purchase a new one.

The device can be delivered with a memory card that is inserted in the device. When the device is energised, there are two possibilities:

- If the inserted memory card contains device-specific data, the device automatically adopts this data. At the time of delivery, the memory card is preloaded with device-specific information. To view the stored data, refer to the file Device Description File.
- If the inserted memory card is empty, the device saves its own data onto the card. A new memory card is empty.

To download the file Device Description File:

Type 8743

Product description

- ▶ Access the page [Type 8743](#)
- ▶ Scroll down to **Downloads > Software**

The data stored on the memory card can be transferred to another device with the same article number. For example, data from a defective device can be transferred to a replacement device.

4 Technical data

4.1 Standards and directives

This product complies with the legal requirements applicable at the time of placing on the market and has been developed and tested in accordance with the relevant European directives/regulations and harmonized standards. The conformity is documented and, if necessary, supported by evidence. The EU Declaration of Conformity can be found behind the respective type on the home page country.burkert.com

4.2 Operating conditions

Ambient temperature	-10...+40 °C
Storage temperature	-10...+70 °C
Degree of protection (EN 60529 / IEC 60529)	IP20 ¹⁾
Medium temperature	-10...+50 °C
Medium	Refer to the type label Clean and dry. Quality classes according to DIN ISO 8573-1.
Operating pressure	max. 10 bar (g)
Relative ambient humidity	Max. 95% at 55 °C (non-condensing)

4.3 Medium data

Calibration medium	Nitrogen (N ₂)
Nominal flow range Q_{nom} (reference to N ₂ (I _N /min))	0.01...100 I _N /min
Turndown ratio	1:20 ($Q_{nom} < 0,025 I_N/min$) 1:50 ($Q_{nom} \geq 0,025 I_N/min$) others on request
Repeatability	±0.1% of the full scale
Measurement accuracy, after 30 minutes warm-up time	±0.8% of the measured value ±0.3% of the full scale If the medium deviates from the calibration medium, the actual measurement accuracy might vary from the value specified in the data sheet.
Response time	< 2 s

¹⁾ When cables or plugs and sockets are connected correctly, verified by Bürkert, not evaluated by UL.

Quality of the medium

NOTICE!

The medium must obey the quality criteria to obey the following requirements:

- ▶ the necessary measurement accuracy of the device
- ▶ to meet the safety requirements
- ▶ to meet the closed-loop control accuracy of an MFC

✓ For further information on the quality criteria, refer to ISO 8573-1.

Criteria	Quality class	Value
Maximum particle size	2	1 µm
Maximum particle density	2	1 mg/m ³
Maximum dew point under pressure	4	3 °C
Maximum oil concentration	1	0.01 mg/m ³

Tab. 3: Quality criteria of the medium, ISO 8573-1, Compressed Air - Part 1: Contaminants and purity classes

4.4 Electrical data

Operating voltage	24 V \pm 10 % residual ripple < 2 %
Power consumption	Refer to type label
Communication interface	Industrial Ethernet: PROFINET, EtherNet/IP, EtherCAT, Modbus TCP
Electrical connections	<ul style="list-style-type: none"> • 3-pin terminal strip, pitch 3.5 mm • 2 RJ45 sockets • service bÜS interface
Minimum temperature rating of the cable to be connected to the field wiring terminals:	75 °C

4.5 Communication

4.5.1 Industrial Ethernet: EtherCAT



Ethernet interface X1, X2	X1: EtherCAT IN X2: EtherCAT OUT
Acyclic communication (CoE)	SDO
Type	Complex Slave
FMMUs	8
Sync managers	4
Transmission speed	100 Mbit/s
Data transport layer	Ethernet II, IEEE 802.3

EtherCAT® is a registered trademark and patented technology, licensed by Beckhoff Automation GmbH, Germany.

4.5.2 Industrial Ethernet: EtherNet/IP

Pre-defined standard objects	Identity Object (0x01) Message Router Object (0x02) Assembly Object (0x04) Connection Manager (0x06) DLR Object (0x47) QoS Object (0x48) TCP/IP Interface Object (0xF5) Ethernet Link Object (0xF6)
DHCP	supported
BOOTP	supported
Transmission speed	10 and 100 Mbit/s
Duplex modes	Half duplex, full duplex, auto-negotiation
MDI modes	MDI, MDI-X, Auto-MDI-X
Data transport layer	Ethernet II, IEEE 802.3
Address Conflict Detection (ACD)	supported
DLR (ring topology)	supported
CIP reset service	Identity Object Reset Service Type 0 and Type 1

4.5.3 Industrial Ethernet: Modbus TCP

Modbus function codes	1, 2, 3, 4, 16
Transmission speed	10 and 100 Mbit/s
Data transport layer	Ethernet II, IEEE 802.3

4.5.4 Industrial Ethernet: PROFINET IO

Topology recognition	LLDP, SNMP V1, MIB2, Physical Device
Minimum cycle time	2 ms
IRT	not supported
MRP media redundancy	MRP client is supported
Other supported functions	DCP, VLAN Priority Tagging, Shared Device
Transmission speed	100 Mbit/s
Data transport layer	Ethernet II, IEEE 802.3
PROFINET IO specification	V2.42
Application Relations (AR)	The device can simultaneously process up to 2 IO ARs, 1 Supervisor AR, and 1 Supervisor DA AR.

4.6 Mechanical data

Housing	Polycarbonate (PC)
Status indicator	Polycarbonate
Parts in contact with the medium	Stainless steel 316 (1.4401), 316L (1.4404, 1.4435), PCTFE, Seal (Refer to the type label) Valve: 1.4310, 1.4113, 1.4305

5 Medium connection



Risk of injury or material damage when working on the device or system.

- ▶ Read and observe the chapter **Safety** [▶ 8] before working on the device or system.

5.1 Possible medium connections

- G-internal-threaded connections according to DIN ISO228/1
- NPT-internal-threaded connections according to ASME/ ANSI B 1.20.1
- Flange connection
- Connections with external-threaded vacuum fittings
- Connections with external-threaded compression fittings
- Tri-Clamp

5.2 Installation procedure



WARNING!

Risk of injury that is due to leakage.

At a low mass flow rate and a high pressure, make sure that the installation is tight. The tightness prevents incorrect measurements or leakage of the medium.

To make sure that the installation is tight, observe the following instructions:

- ▶ Use compression fittings. Mount the compression fittings in a way that they are not subject to any stresses.
- ▶ Use pipes with diameter that is adapted to the medium connection of the device, and a smooth surface.

NOTICE!

Malfunction that is due to contamination.

If a contaminated medium is used, then install a filter upstream of the device. The filter mesh-size must be smaller than 25 µm. The filter ensures problem-free functioning of the device.

5.2.1 G1/8"-internal-threaded connections

- ▶ Remove the protective cap that closes the threaded connection.
- ▶ Do the medium connection on one side of the device.
- ▶ Obey the instructions that are given by the manufacturer of the fitting used.
- ▶ Obey the torques that are given by the manufacturer of the fitting used.
- ▶ Do the medium connection on the other side of the device in the same way.

5.2.2 NPT1/8"-internal-threaded connections

- ▶ Do the medium connection on one side of the device.

- ▶ Obey the instructions that are given by the manufacturer of the fitting used.
- ▶ Obey the torques that are given by the manufacturer of the fitting used.
- ▶ Do the medium connection on the other side of the device in the same way.

5.2.3 Flange connections

A variant with flange connections is mounted on a process connection plate by the manufacturer.

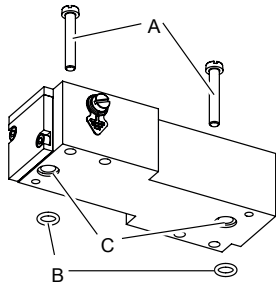

- ▶ Use the M4 screws [A] and O-ring sealings [B] delivered with the device.
- ▶ Place the O-ring sealings in the cavity [C] of the base block.
- ▶ Tighten the screws to a torque of 2,7...2,9 N·m (1,99...2,14 lbf·ft).

Fig. 7: Flange connection with screws and O-ring sealings

5.2.4 Connections with external-threaded vacuum fittings

- ▶ Remove the protective cap that closes the connection.
- ▶ Do the medium connection on one side of the device.
- ▶ Obey the instructions that are given by the manufacturer of the fitting used.
- ▶ **CAUTION! To avoid damage on the sealing of the medium connection, please make sure to lock the hexagonal part in place with a second wrench.**
Obey the torques that are given by the manufacturer of the fitting used.
- ▶ Do the medium connection on the other side of the device in the same way.

5.2.5 Connections with external-threaded compression fittings

- ▶ Do the medium connection on one side of the device.
- ▶ Obey the instructions that are given by the manufacturer of the fitting used.
- ▶ **CAUTION! To avoid damage on the sealing of the medium connection, please make sure to lock the hexagonal part in place with a second wrench.**
Obey the torques that are given by the manufacturer of the fitting used.
- ▶ Do the medium connection on the other side of the device in the same way.

5.2.6 Tri-clamp connections

- ▶ Remove the protective cap that closes the threaded connection.
- ▶ Do the medium connection on one side of the device.
- ▶ Obey the instructions that are given by the manufacturer of the fitting used.
- ▶ Do the medium connection on the other side of the device in the same way.

6 Electrical connection



Risk of injury or material damage when working on the device or system.

- ▶ Read and observe the chapter [Safety \[▶ 8\]](#) before working on the device or system.

6.1 Additional documentation

Further documentation concerning the product:

- ▶ Access the page [Type 8743](#)
- ▶ Scroll down to **Downloads**
- ▶ Or enter the article number from the type label in the search bar.

6.2 Wire the variant Industrial Ethernet

NOTICE!

Requirements for the correct operation of the device.

- ▶ Use a power supply unit with sufficient power.
- ▶ Use only Industrial Ethernet shielded cables with a category CAT-5e or higher.
- ▶ Connect each cable end to the functional earth.
- ▶ For an MFC pay attention to the maximum permissible residual ripple on the operating voltage (residual ripple < 2 %).

NOTICE!

UL approved versions must be supplied in one of the following ways:

- ▶ "Limited Energy Circuit" (LEC), according to UL / IEC61010-1
- ▶ "Limited Power Source" (LPS), according to UL / IEC60950
- ▶ SELV / PELV with UL-approved overcurrent protection, designed according to UL / IEC61010-1, Table 18 (e.g. Block PM-0124-020-0)
- ▶ NEC Class 2 power supply unit

Connecting the power supply and the functional earth

3-pin terminal strip	Pin	Assignment
	1	FE (functional earth)
	2	DGND
	3	+24 V \equiv

Tab. 4: Terminal assignment of the 3-pin terminal strip of the device

- ▶ Open the cover of the device.
- ▶ Connect the conductors according to the figure.

- ▶ Earth the device. Refer to [Connect the functional earth \[▶ 26\]](#)
- ▶ Tighten the conductors at a torque between 0.22...0.25 N (0.16...0.18 lbf·ft.)

Connecting the Industrial Ethernet

The cable shield is connected by the housing of the cable plug.

Both RJ45 sockets have the same pin assignment.

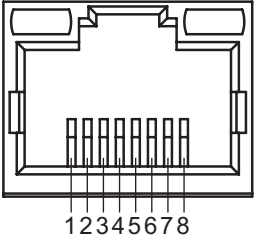
RJ45	Pin	Assignment
	1	TX+
	2	TX-
	3	RX+
	4	N. C.
	5	N. C.
	6	RX-
	7	N. C.
	8	N. C.
Housing		FE

Tab. 5: Pin assignment of an RJ45 socket of the device

- ▶ If a protocol other than EtherCAT is used, plug an Ethernet cable in one or both sockets.
- ▶ If the EtherCAT protocol is used, plug the incoming Ethernet cable (coming from the PLC) into the socket marked ETH1 and plug the outgoing Ethernet cable into the socket marked ETH2.

6.3 Change the network parameters



The Industrial Ethernet variants Ethernet/IP and ModbusTCP have the same default IP address 192.168.1.100, Profinet devices have 0.0.0.0 by default.

- ▶ Before commissioning the device, change its network parameters.
- ▶ If several devices must be connected to the same Industrial Ethernet network, then connect one device at a time and change its network parameters.

6.3.1 Over the product web server

NOTICE!

Security risk due to default passwords.

Unauthorised persons can log in to the web server and change the parameters.

- ▶ Change the default passwords.
- ▶ If the web server is not required, disable access using Bürkert Communicator. Refer to [Configuration with Bürkert Communicator \[▶ 28\]](#).

Prerequisites:

- The industrial Ethernet variant is not EtherCAT
- Digital device (PC, tablet,...) with a web browser.
- Possibly, a USB-Ethernet adapter.
- ▶ Connect the device to the digital device with an Ethernet cable. Alternatively, connect the device to the PC with a USB-Ethernet adapter.
- ▶ Energise the digital device and the device.
- ▶ If the device is connected to the digital device over a USB-Ethernet adapter, then configure the IP address of the USB-Ethernet adapter. Else, configure the IP address of the network card of the digital device.
- ▶ Change the IP address to 192.168.1.xxx, where xxx is different from 100.
- ▶ Open the web browser. In the address bar of the web browser, enter 192.168.1.100.
 - ✓ The home page of the web server opens. Some device data are shown.
- ▶ Open a web server session, to configure the network parameters of the device.
- ▶ If you are not automatically invited to log in, select **Login**.
- ▶ **User name:** enter admin
- ▶ **User password:** enter admin
- ▶ Click **Login**.
- ▶ Change the default passwords with customised passwords.
- ▶ Change the network parameters of the device.
- ▶ Select **Industrial communication** > **Configuration**.
- ▶ Change the parameters.
- ▶ To save the changes, select **Apply**.
- ▶ To update the parameters, select **Restart**.
- ✓ The device restarts.
- ✓ The network parameters of the device are changed.

6.3.2 Over the Bürkert Communicator software

- ▶ Connect the device to the Bürkert Communicator software. Refer to [Configuration with Bürkert Communicator \[▶ 28\]](#).
- ▶ Change the network parameters of the device.
- ▶ Select **Industrial communication** > **Parameter**.
- ▶ Change the parameters.
- ▶ To update the parameters, restart the device.
- ✓ The device restarts.
- ✓ The network parameters of the device are changed.

6.4 Connect the functional earth

WARNING!

Risk of ignition and risk of fire that are due to electrostatic discharge.

An electrostatic discharge of the device can ignite combustible gas vapours.

- ▶ To avoid a build up of electrostatic charge, connect the housing to the functional earth.
- ▶ If the functional earth is not attached, then the requirements of the EMC directive are not met.

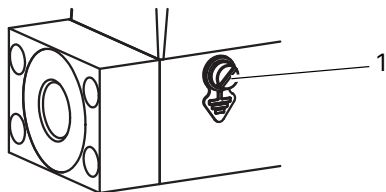

Fig. 8: Location of the M4 screw for the connection of the functional earth

1 M4 screw

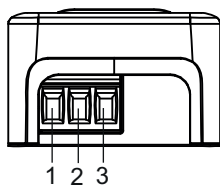

Fig. 9: Connection option on Industrial Ethernet variant

- ▶ Use a green-and-yellow cable that is as short as possible. And the cable cross-section must be at least equal to the cross section of the power-supply cable.
- ▶ With a flat screwdriver of size 6.5 mm, loosen the M4 screw.
- ▶ Attach the green-and-yellow cable to the M4 screw with a cable lug.
- ▶ Tighten the M4 screw to a torque of 1,8 N·m...2 N·m (1,33 lbf·ft...1,47 lbf·ft).
- ▶ Use a green-and-yellow cable that is as short as possible. And the cable cross-section must be at least equal to the cross section of the power-supply cable.
- ▶ Attach the green-and-yellow cable to the terminal 1 of the 3-pin terminal strip with a torque of 0.22...0.25 N·m (0.16...0.18 lbf·ft).

7 Commissioning



Risk of injury or material damage when working on the device or system.

- ▶ Read and observe the chapter [Safety \[▶ 8\]](#) before working on the device or system.
-

7.1 Commissioning procedure

- ▶ Pressurise the pipes with medium.
 - ▶ Flush the pipes with medium at the calibration pressure.
 - ▶ Vent the pipes completely.
 - ▶ Check if the memory card is inserted.
 - ▶ Energise the device.
 - ▶ If the device is an MFC, and the medium is not the calibration medium or the pressure conditions have changed, then run the Autotune function. Refer to [Optimise the closed-loop control parameters \[▶ 32\]](#)
- ✓ The device operates normally.

8 Configuration with Bürkert Communicator

8.1 Setting tools



The MassFlowCommunicator is another PC software that is not compatible with the device. The MassFlowCommunicator software cannot be used to configure or operate the device.

Settings can be made with the Type 8920 Bürkert Communicator. For general information about the Bürkert Communicator, refer to the operating instructions of Type 8920.

- ▶ Access the page [Type 8920](#)
- ▶ Scroll down to **Downloads** > **User Manuals**

8.2 Connect to the Bürkert Communicator

- ▶ Use the USB-büS-Interface set, article number 00772551.
- ▶ Download the latest version of the Type 8920 Bürkert Communicator.
- ▶ Access the page [Type 8920](#)
- ▶ Scroll down to **Downloads** > **Software**
- ▶ Install the Bürkert Communicator on a PC. During installation, the büS stick must not be connected to the PC.
- ▶ Assemble the parts of the USB-büS-Interface set.



Fig. 10: Assembled parts of the USB-büS-Interface set

- ▶ Set the termination-resistance switch of the büS stick to ON.
- ▶ Insert the büS stick into a USB port of the PC.
- ▶ Energise the device. Refer to [Electrical connection \[▶ 23\]](#)
- ▶ Insert the micro-USB connector into the büS interface of the device. Refer to [Product description \[▶ 11\]](#)
- ▶ Wait until the driver of the büS stick has been completely installed on the PC.
- ▶ Start the Bürkert Communicator.
- ▶ Click on  in the Bürkert Communicator to establish the communication with the device.
 - ✓ A window opens.
- ▶ Select **Connect via USB (büS Stick)**.

- ▶ Select the port Bürkert USB bÜS stick, click on **Finish** and wait until the device symbol appears in the list of devices.
- ▶ In the navigation area, click on the symbol related to the device: The device menu appears.

8.3 Setting the Industrial Ethernet address

- ▶ To set the fieldbus address, use the Bürkert Communicator.
- ▶ Or use the man-machine interface of the PLC the device is connected to.
- ▶ If the address is changed and to avoid malfunction of the device, restart the device by turning off and on the power supply.

8.4 Functions

8.4.1 Shut-Off threshold for the valve

A shut-Off threshold ensures the sealing function of the control valve (except valve with PCTFE seat sealing). If the used set-point value is below the shut-off threshold, the control signal for the valve is set to 0% immediately.

8.4.2 Cut-Off threshold for actual flow

A cut-off threshold for the actual flow is calculated from the nominal flow, the measuring span and a calculation factor. Measured values below the calculated cut-off threshold will be displayed as zero actual flow.

8.5 Change of medium

With the Bürkert Communicator, it is possible to change the medium by using a LUA-Script which can be downloaded at country.burkert.com.

To perform the LUA-Script:

- ▶ Connect the device to the Bürkert Communicator software. Refer to [Connect to the Bürkert Communicator \[▶ 28\]](#)
- ▶ Select the device.
- ▶ Go to **File > Scripts**.
- ▶ Browse the downloaded zip-File.

✓ The procedure of changing medium starts.

8.6 User-defined adjustment

At delivery the device is calibrated by the manufacturer.

With the Bürkert Communicator, it is possible to define an adjustment procedure with up to 32 calibration points.

This procedure is described in device specific **Documents and tools** in the Bürkert Communicator.

- ▶ Connect the device to the Bürkert Communicator. Refer to [Connect to the Bürkert Communicator \[▶ 28\]](#)

8.7 Zero point adjustment

It is possible to perform a zero point adjustment procedure to adapt the sensor characteristic curve to the current conditions (mounting/installation position, medium, operating pressure). The device will be calibrated in installation position in any case. It is possible to use another installation position. Afterwards a zero point adjustment procedure is necessary.

- ▶ Start the communication with the Bürkert Communicator. Refer to [Connect to the Bürkert Communicator \[▶ 28\]](#)
- ▶ Choose the device.
- ▶ Select **Sensor** > **Diagnostics** > **Start zero point adjustment**
- ✓ The procedure starts.
- ✓ The device switches the namur status to orange.

8.8 Set-point value sources and operation modes

Different sources can set the process set-point value. Select one active source at a time.

Change the set-point value source during operation if required. Changing the set-point value source also changes the device operating mode.

When energising the device for the first time, the device enters a short initialisation phase and then switches to the normal operation mode.

- ▶ Connect the device to the Bürkert Communicator. Refer to [Connect to the Bürkert Communicator \[▶ 28\]](#).
- ▶ Select the device.
- ▶ Go to **Controller** > **Parameter** > **Set-point value** > **Set-point value source**.



The **Set-point value source** remains after a restart. It resets only when the selected source is **Manual set-point value** or **Analyze system**.

Set-point value source	Description	Operation mode
Automatic	The fieldbus sets the set-point value. If several fieldbus participants simultaneously send values, the device uses the last received value.	Normal operation mode (Closed Loop)
Manual set-point value	For testing or to prevent overwriting by other fieldbus participants.	Normal operation mode (Closed Loop)
Stored setpoint	To use a fixed set-point value (w). After a device restart, the fixed set-point value remains active.	Normal operation mode (Closed Loop)
Open-loop control mode	To directly set the position set-point value (y) to the actuator. The menu Actuator > Parameter > Actuating variable provides the used position set-point value (y). Restarting the device sets the position set-point value (y) to zero.	Open-loop control mode
Analyze system	The device operates in normal operation mode according to a predefined chronological sequence of set-point values. Use the resulting diagram with the graphical process values to analyse the system with the Bürkert Communicator.	Analyse the system

Tab. 6: Set-point value sources and operation modes

8.9 Operation modes

When energising the device for the first time, the device enters a short initialisation phase and then switches to the normal operation mode. Refer to [Normal operation mode \[▶ 31\]](#)

- ▶ To change the operation mode, change the source for the set-point values. Refer to [Select the source that gives the set-point value \[▶ 33\]](#)

The operation mode is kept after a device restart, except when the device performs the function **Analyze system**.

8.10 Normal operation mode

The normal operation mode is active when energising the device for the first time.



If the valve seat seal is made of a hard material such as PCTFE, then the control valve may not be tight.

Valves with a seat size of 0.05 mm or 0.1 mm have a seat seal made of a hard material.

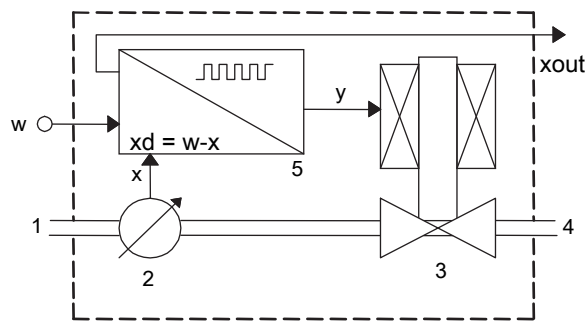

Fig. 11: Function diagram of the MFC with control valve

1 Medium inlet	2 Sensor
3 Control valve	4 Medium outlet
5 Electronics	x measured value of the mass flow rate
y set-point position of the valve	w set-point value of the mass flow rate

The sensor measures the mass flow rate and compares the measured value x with the set-point value w . The device calculates the set-point position value y of the actuator.

- The set-point position value y determines the opening of the control valve. For example, if the set-point position value y is equal to 10%, then the opening of the control valve is 10%.

The transmission means of the set-point value w and the measured value of the flow rate depends on the device.

- ▶ If the operating conditions have changed, then optimise the closed-loop control parameters. Refer to [Optimise the closed-loop control parameters \[▶ 32\]](#)
- ▶ To change the operation mode, change the source for the set-point value. Refer to [Select the source that gives the set-point value \[▶ 33\]](#)

8.10.1 Industrial Ethernet variant

After applying the operating voltage, the device enters a short initialisation phase and then switches to the **Automatic** operation mode.

- ▶ To change the control mode, i. e. to change the source for the set-point values. Refer to [Select the source that gives the set-point value \[▶ 33\]](#)
- ▶ To change the control parameters, use the Bürkert Communicator.

8.11 Optimise the closed-loop control parameters

The closed-loop control parameters of the device can be optimised for the current operating conditions with a function that is called Autotune.

- Run the Autotune function when the device is started for the first time.
- If the operating conditions have changed, then run the Autotune function.

If the device detects that the pipe is empty, then the Autotune function cannot be started.

When the Autotune is running:

- ▶ Do not interrupt the power supply to the device.
- ▶ Keep the supply pressure constant.

 **WARNING!**

Risk of injury from flowing medium.

While the Autotune function is running, the mass flow rate value can be higher than the nominal flow rate value.

- ▶ Before running the Autotune function, make sure that no danger can occur if the mass flow rate value increases.
- ▶ Trigger the Autotune function with one of the following means:
 - ▶ over the fieldbus
 - ▶ with the Bürkert Communicator. Refer to [Connect to the Bürkert Communicator \[▶ 28\]](#)
- ✓ The Autotune runs and the status indicator is orange.
- ✓ A zero-point adjustment will be performed at the beginning of the autotune function.
- ✓ The device temporarily stops regulating the flow rate in the pipe.
- ✓ When the function is completed, the device returns to its previous operating mode.
- ✓ If the function is completed successfully, then the optimised closed-loop control parameters are transferred to the hard memory of the device.

8.12 Select the source that gives the set-point value

The process set-point value can be set by different sources. It is possible to select which source is active at a time. The source for the set-point value can be changed during operation.

If the source for the set-point value is changed, then the operation mode of the device is changed.

To change the source for the set-point value, change the setting of the parameter **Set-point value source** with the Bürkert Communicator. Refer to [Connect to the Bürkert Communicator \[▶ 28\]](#)



The setting of the parameter **Set-point value source** is kept after a restart, except when the device performs the function **Analyze system** or the set-point value source was set to manual set-point.

It is possible to alternatively change the related object. Refer to the file Device Description File.

- ▶ Access the page [Type 8743](#)
- ▶ Scroll down to **Downloads** > **Software**

Possible choices for the parameter **Set-point value source**

Automatic	The set-point value is set via the fieldbus. If different fieldbus participants simultaneously specify a set-point value for the device, it is always the last set value that is used.
Manual set-point value	To manually give in a set-point value for testing purposes or to make sure that the set-point value is not overwritten by other fieldbus participants.
Stored setpoint	To use a fixed set-point value (w). If the device is restarted, then the fixed set-point value remains active. Refer to Normal operation mode [▶ 31]
Open-loop control mode	To directly set the set-point position (y) to the actuator. The value that is given in the menu Actuator > Parameter > Actuating variable is the setpoint position (y) that is used. A restart of the device sets the set-point position (y) to zero. Refer to Normal operation mode [▶ 31]
Analyze system	The device operates in the normal operation mode, but according to a predefined chronological sequence with set-point values. Use the resulting diagram in combination with the graphical representation of process values to analyse the system with the Bürkert Communicator.

8.13 Set-point values without communication

The function makes it possible to specify the set-point values of the device even if the communication with the external set-point value provider (for example a PLC) is broken. If the function is used, then the set-point is kept constant.



By using the function, the medium can continue to flow even if the communication is broken.

- ▶ Make sure the process is safe when the function is used.

- ▶ To use the function, refer to the file Device Description File.
- ▶ Access the page [Type 8743](#)
- ▶ Scroll down to **Downloads** > **Software**
- ▶ The configuration is available under **Controller** > **Parameter** > **Setpoint** > **Advanced settings** > **Connection abort behaviour**

9 Maintenance

If the device is operated according to the Operating instructions, then the device is maintenance-free.



Risk of injury or material damage when working on the device or system.

- ▶ Read and observe the chapter [Safety \[▶ 8\]](#) before working on the device or system.

9.1 Service tasks and intervals

The device is equipped with a stainless steel mesh-filter, which is located in the medium connection. If the device is exposed to a demanding environment or contaminated medium, the filter must be checked regularly. If necessary, the filter can be cleaned.

9.2 Inspect and clean the stainless steel mesh-filter

The inspection and possibly cleaning of the stainless steel meshfilter must be done at regular intervals. The inspection frequency and cleaning frequency depend on the measured medium.

If a contaminated medium is used, then clean the stainless steel mesh-filter immediately. If the stainless steel mesh-filter is contaminated, then replace it with a new one.

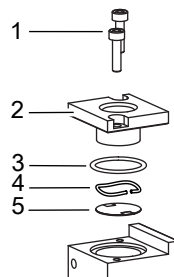

Fig. 12: Parts in contact with the medium

1 Screws	2 Flange plate
3 O-ring	4 Spring
5 Stainless steel mesh-filter	

- ▶ Position the device upright with the medium inlet at the top.
- ▶ With an hexagon key of size 2.5 mm, loosen the screws [1] and remove the flange plate [2].
- ▶ With a pair of tweezers, remove the O-ring [3], the wave spring [4] and the mesh filter [5].
- ▶ **CAUTION! Do not clean the mesh filter with tap water.** Clean the stainless steel mesh-filter [5] with acetone, isopropanol or compressed air.
- ▶ Dry the mesh filter.
- ▶ **CAUTION! Before mounting the parts back, make sure that the fine side of the mesh filter [5] faces the flange plate [2]**
- ▶ Mount the parts back in the correct order.
- ▶ Make sure that the mesh filter and the O-ring are seated flat and not tilted.

- ▶ Insert the flange plate [2] and the screws [1].
- ▶ Tighten the screws to a torque of 1.2 N·m (0,88 lbf·ft).

9.3 Calibration

The device is factory calibrated.

A regular check of the accuracy depends on the use and the individual requirements of the application. Mechanical wear, ageing of the materials, temperature changes, frequent use or contamination can affect the measuring accuracy over time. It is therefore advisable to calibrate measuring devices regularly to ensure precise measurement results at all times. The customer is responsible for determining the timing of the periodic inspection. We recommend checking the calibration after 12 months. If required, contact [Bürkert](#) for further information on calibrations and to arrange an appointment.



The calibration only applies to the primary measuring function of the measuring device. The secondary outputs are not covered by the calibration.

9.4 Replace the memory card

- ▶ De-energise the device.
- ▶ With tweezers slightly push the memory card to the stop in the device and release. The old memory card comes out.
- ▶ Pay attention to the insertion direction of the memory card.

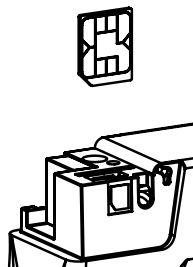

Fig. 13: Insertion direction of the memory card

- ▶ Push the new memory card in the slot until you hear a locking noise. If the memory card comes out, the locking failed.

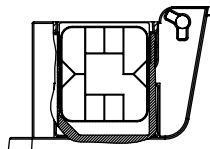

Fig. 14: Inserted memory card

- ▶ Restart the device to write the data on the new memory card. Possible problems related to the memory card are given in [Troubleshooting](#) [▶ 37]

10 Troubleshooting

10.1 Status indicator is red

Cause	Solution
The supply voltage is out of the error range. The device can be damaged.	<ul style="list-style-type: none"> ▶ Operate the device within the specifications. <p>If the status indicator does not change, then send the device back to Bürkert.</p>
The sensor, the internal memory or the device is defective.	<p>Maintenance is needed.</p> <ul style="list-style-type: none"> ▶ Contact the manufacturer.
The device has been operated outside the temperature limits. The device can be damaged.	<ul style="list-style-type: none"> ▶ Operate the device within the specifications. <p>If the status indicator does not change, then send the device back to Bürkert.</p>
No proper connection to the PLC.	<ul style="list-style-type: none"> ▶ Check the wiring. ▶ Check the status of the PLC. <p>EtherCAT variant</p> <ul style="list-style-type: none"> ▶ If the EtherCAT protocol is used, make sure the incoming cable (reception from the PLC) is inserted in the ETH1 port and the outgoing cable is inserted in the ETH2 port.
Incorrect Autotune or Autotune aborted. After a restart of the device, the error will be reset.	<ul style="list-style-type: none"> ▶ Make sure that the medium flows through the device. ▶ Check the Q_{nom} of the device. ▶ Start the Autotune again. <p>After a restart of the device, the error will be reset.</p>

10.2 Status indicator is orange

Cause	Solution
A calibration procedure is in progress.	<ul style="list-style-type: none"> ▶ Wait until the procedure is completed.
PROFINET variant	
PLC is in Stop mode.	<ul style="list-style-type: none"> ▶ Activate the PLC.
The Autotune is in progress.	<ul style="list-style-type: none"> ▶ Wait until the procedure is completed.
The operation mode of the device is set to Open-loop control mode , Manual set-point value or Analyze system .	<p>Refer to Select the source that gives the set-point value [▶ 33]</p>

10.3 Status indicator is yellow



The yellow state is displayed up to 60 seconds after electrical power up. The device needs this time to reach the normal operation mode. After this initialisation the device will change to the green state.

Cause	Solution
<p>One of the following values is out of specification. The sensor or the device can be damaged.</p> <ul style="list-style-type: none"> the medium temperature the device temperature the supply voltage 	<ul style="list-style-type: none"> Operate the device within the specifications. <p>If the status indicator does not change, then send the device back to Bürkert.</p>
<p>A change of the Ethernet protocol is in progress.</p>	<ul style="list-style-type: none"> Wait until the procedure is completed.
<p>The set-point position for the actuator has (almost) reached 100%. The set-point value cannot be reached.</p>	<ul style="list-style-type: none"> Increase the inlet pressure or decrease the output pressure. If the pressure drop in the pipe is too high, then reduce the pressure drop. If the filters installed in the pipe are dirty, then clean the filters.

10.4 Status indicator is blue

Cause	Solution
<p>Error in the internal memory.</p>	<p>Maintenance is needed.</p> <ul style="list-style-type: none"> Contact the manufacturer.

10.5 Status indicator is off

Cause	Solution
<p>The device is not energised.</p>	<ul style="list-style-type: none"> Check the wiring. Make sure that the voltage supply is 24 V $\overline{=}$. Make sure that the power supply source is working properly.

10.6 Status indicator goes out periodically

Cause	Solution
<p>The power supply is intermittently dropping and the device restarts.</p>	<ul style="list-style-type: none"> Use a power supply with sufficient power output.

Cause	Solution
The voltage drop in the connecting cable is too high.	<ul style="list-style-type: none"> ▶ Increase the cross-section of the cable and reduce the cable length.

10.7 Replacement device adopts none of the values from the defective device

Cause	Solution
The article number of the replacement device is different from the article number of the defective device.	<ul style="list-style-type: none"> ▶ Use a replacement device that has the same article number than the defective device. <p>Values can only be transferred between devices with the same article numbers.</p>
The memory card is defective. The device could not write any values to the memory card.	<ul style="list-style-type: none"> ▶ Replace the memory card. <p>Refer to Replace the memory card [▶ 36].</p>

10.8 Replacement device does not adopt all of the values from the defective device

Cause	Solution
The device description of the replacement device is different from the device structure of the defective device. Only the existing values of the defective device can be adopted by the replacement device.	<ul style="list-style-type: none"> ▶ Use the Bürkert Communicator to configure the new values of the replacement device.

10.9 No mass flow rate

Cause	Solution
The pipes are too large or not yet fully vented.	<ul style="list-style-type: none"> ▶ Vent the pipe. ▶ Change the pipe diameter.
The flow-rate value is below the cut-off limit.	<ul style="list-style-type: none"> ▶ If the cut-off limit is too high, decrease the value of the cut-off limit. <p>Refer to Cut-off.</p>
<p>The device is not in the normal operation mode, refer to Operation modes [▶ 31].</p> <p>The device is possibly running one of the functions described in Select the source that gives the set-point value [▶ 33]</p>	<ul style="list-style-type: none"> ▶ If the device is not running one of the functions described in Select the source that gives the set-point value [▶ 33], then check the other possible causes of the problem.

Cause	Solution
The set-point value is lower than the zero-point shut-off limit.	<ul style="list-style-type: none"> ▶ Increase the set-point value until it is higher than 2% of the nominal flow rate.

10.10 Unstable measured value

Cause	Solution
Functional earth (FE) is not connected properly.	<ul style="list-style-type: none"> ▶ To connect the functional earth, use a green-and-yellow cable that is as short as possible. the cable cross-section must be at least equal to the cross section of the power-supply cable. Refer to Connect the functional earth [▶ 26]
The residual ripple on the voltage supply is too high.	<ul style="list-style-type: none"> ▶ Use a supply voltage that conforms to the technical data given in Technical data [▶ 17]
The device must compensate for irregularities in an unstable pressure supply caused, for example, by pumps.	<ul style="list-style-type: none"> ▶ Install a suitable pressure regulator in front of the device. ▶ Install a buffer tank to absorb the pressure fluctuations.
The controller is unstable.	<ul style="list-style-type: none"> ▶ Run the Autotune function to adapt to the operating conditions.

10.11 Set-point value at 0 %, but medium still flows

Cause	Solution
The connected actuator is a proportional valve and the operating pressure is above the tight sealing pressure of the proportional valve.	<ul style="list-style-type: none"> ▶ Reduce the operating pressure. ▶ To eliminate the defect, return the device to the manufacturer.

10.12 Set-point value at 0 %, no mass flow, but a non-zero mass flow rate is measured

Cause	Solution
The installation position of the device is incorrect.	<ul style="list-style-type: none"> ▶ Install the device as recommended in Medium connection [▶ 21] ▶ Run the Autotune function to adapt to the operating conditions. ▶ Run a zero point adjustment. Refer to Zero point adjustment [▶ 30]
The medium is different from the medium specified during the calibration.	<ul style="list-style-type: none"> ▶ Use the specified medium or send the device to the manufacturer for calibration with the new medium.

10.13 Set-point value is not reached

Cause	Solution
The mesh filter is clogged.	<ul style="list-style-type: none"> ▶ Clean or replace the mesh filter.
The outlet pressure is too high.	<ul style="list-style-type: none"> ▶ Run the Autotune function to adapt to the operating conditions. ▶ Make sure that the pipe diameters and the pipe lengths are adapted. ▶ If the medium connection pipes after the device are dirty, then clean them.
The inlet pressure is too low.	<ul style="list-style-type: none"> ▶ Increase the inlet pressure to the calibration pressure value. ▶ Make sure that the pipe diameters and the pipe lengths are adapted.

10.14 Network status indicator

LED indicator	Meaning	Action
Link/Act-LED (green) fast blinking	Connection to the parent protocol layer is established.	-
Link/Act-LED (green) slow blinking (directly after restart)	Connection to the protocol layer is searched.	-
Link/Act-LED (green) slow blinking (20 s after restart)	No connection to the parent protocol layer.	▶ Check the cable.
Link/Act-LED (green) is OFF.	No connection to the network.	▶ Check the cable.
Link-LED (yellow) is ON	Connection to the network is established.	-
Link LED (yellow) is not lit	Not connected to network.	▶ Check cable.

Tab. 7: Meaning of the LED indicator

11 Uninstallation

11.1 Dismantling

- ▶ Relieve the medium pressure in the installation.
- ▶ Flush the device with a neutral medium (for example nitrogen)
- ▶ Relieve the flushing medium pressure in the installation.
- ▶ De-energise the device.
- ▶ Remove the electrical wiring.
- ▶ Disconnect the medium connections.
- ▶ Remove the device.

12 Spare parts and accessories



Risk of injury and/or damage due to incorrect parts.

- ▶ Use only original accessories and original spare parts from Bürkert.



Order the parts directly on our [eShop](#).

12.1 Electrical accessories

- ▶ For further accessories, refer to the data sheet.

USB-büS-interface set, without power supply	772551
Memory card	on request

12.2 Compression fittings for a device with G-internal-threaded connections

The threaded pipe-connection plates of the device obey standard DIN ISO 228/1. If the pipe fittings are not delivered with the device, then choose pipe fittings that are adapted to the medium connection of the device. Also order the seal depending on the medium connection and the pipe diameter.

Device internal-threaded connection in accordance with DIN ISO 228/1	Pipe diameter	Article number	
		Stainless steel compression-fitting	Seal (1 piece)
G 1/4	6 mm	901538	901575 (Copper)
G 1/4	8 mm	901540	
G 1/4	1/4"	901551	901579 (Rubber steel)
G 1/4	3/8"	901553	

Tab. 8: Stainless steel compression fittings and related seals

12.3 Additional software

Bürkert Communicator	Download from country.burkert.com
----------------------	---

Tab. 9: Documentation and software

13 Logistics

13.1 Transport and storage

- ▶ Protect the device against moisture and dirt in the original packaging during transportation and storage.
- ▶ Avoid UV radiation and direct sunlight.
- ▶ Protect connections, if present, from damage with protective caps.
- ▶ Observe the permitted storage temperature.
- ▶ Remove cables, connectors, external filters and installation equipment.
- ▶ Clean and vent contaminated devices.

13.2 Return



No work or tests will be carried out on the device until a valid Contamination Declaration has been received.

- ▶ To return a used device to Bürkert, contact the Bürkert sales office. A return number is required.

13.3 Disposal

Environmentally friendly disposal



- ▶ Follow national regulations regarding disposal and the environment.
- ▶ Collect electrical and electronic devices separately and dispose of them as special waste.

Further information at country.burkert.com