

Type 8743

Mass flow controller (MFC) for gases analogue

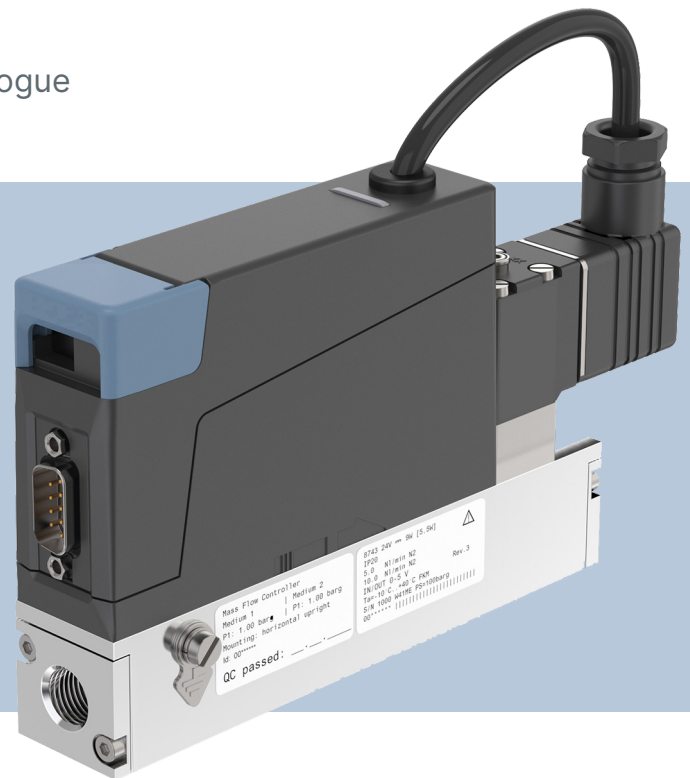

Operating Instructions for specific variant

We reserve the right to make technical changes without notice.

© Bürkert SAS 2023-2026

Technical documentation 2603/04_GBen_424237579_18014399813614603 / Original EN

Table of contents

| | | |
|----------|--|-----------|
| 1 | About this document | 5 |
| 1.1 | Symbols | 5 |
| 1.2 | Terms and abbreviations | 6 |
| 1.3 | Manufacturer | 6 |
| 2 | Safety | 7 |
| 2.1 | Intended use | 7 |
| 2.2 | Safety instructions | 7 |
| 3 | Product description | 10 |
| 3.1 | Product overview | 10 |
| 3.2 | Product identification | 11 |
| 3.2.1 | Type label | 11 |
| 3.2.2 | Calibration label | 11 |
| 3.2.3 | Conformity marking | 12 |
| 3.2.4 | Symbols and markings on device | 12 |
| 3.3 | Display elements | 12 |
| 3.3.1 | Status indicator | 12 |
| 3.3.2 | NAMUR mode | 12 |
| 3.4 | Functionality | 13 |
| 3.4.1 | Service-büS interface | 13 |
| 3.4.2 | Control valve | 13 |
| 3.4.3 | Memory card | 14 |
| 4 | Technical data | 15 |
| 4.1 | Standards and directives | 15 |
| 4.2 | Operating conditions | 15 |
| 4.3 | Medium data | 15 |
| 4.4 | Electrical data | 17 |
| 4.5 | Mechanical data | 17 |
| 5 | Medium connection | 18 |
| 5.1 | Possible medium connections | 18 |
| 5.2 | Installation procedure | 18 |
| 5.2.1 | G1/8"-internal-threaded connections | 18 |
| 5.2.2 | NPT1/8"-internal-threaded connections | 18 |
| 5.2.3 | Flange connections | 19 |
| 5.2.4 | Connections with external-threaded vacuum fittings | 19 |
| 5.2.5 | Connections with external-threaded compression fittings | 19 |
| 5.2.6 | Tri-clamp connections | 19 |
| 6 | Electrical connection | 20 |
| 6.1 | Additional documentation | 20 |
| 6.2 | Wire the variant Analogue with D-sub DE-9 male connector | 20 |
| 6.2.1 | Digital input | 21 |
| 6.2.2 | Relay output | 22 |
| 6.3 | Wire the variant Analogue with a 6-pin terminal strip | 23 |
| 6.4 | Connect the functional earth | 24 |
| 7 | Commissioning | 25 |

| | | |
|-----------|---|-----------|
| 7.1 | Commissioning procedure | 25 |
| 8 | Configuration with Bürkert Communicator | 26 |
| 8.1 | Setting tools | 26 |
| 8.2 | Connect to the Bürkert Communicator | 26 |
| 8.3 | Functions | 27 |
| 8.3.1 | Shut-Off threshold for the valve | 27 |
| 8.3.2 | Cut-Off threshold for actual flow | 27 |
| 8.4 | Change of medium | 27 |
| 8.5 | User-defined adjustment | 27 |
| 8.6 | Zero point adjustment | 28 |
| 8.7 | Set-point value sources and operation modes | 28 |
| 8.8 | Operation modes | 29 |
| 8.9 | Normal operation mode | 29 |
| 8.9.1 | Analogue variant | 30 |
| 8.10 | Optimise the closed-loop control parameters | 31 |
| 8.11 | Select the source that gives the set-point value | 31 |
| 9 | Maintenance | 33 |
| 9.1 | Service tasks and intervals | 33 |
| 9.2 | Inspect and clean the stainless steel mesh-filter | 33 |
| 9.3 | Calibration | 34 |
| 9.4 | Replace the memory card | 34 |
| 10 | Troubleshooting | 35 |
| 10.1 | Status indicator is red | 35 |
| 10.2 | Status indicator is orange | 35 |
| 10.3 | Status indicator is yellow | 35 |
| 10.4 | Status indicator is blue | 36 |
| 10.5 | Status indicator is off | 36 |
| 10.6 | Status indicator goes out periodically | 36 |
| 10.7 | Replacement device adopts none of the values from the defective device | 37 |
| 10.8 | Replacement device does not adopt all of the values from the defective device | 37 |
| 10.9 | No mass flow rate | 37 |
| 10.10 | Unstable measured value | 38 |
| 10.11 | Set-point value at 0 %, but medium still flows | 38 |
| 10.12 | Set-point value at 0 %, no mass flow, but a non-zero mass flow rate is measured | 38 |
| 10.13 | Set-point value is not reached | 39 |
| 11 | Uninstallation | 40 |
| 11.1 | Dismantling | 40 |
| 12 | Spare parts and accessories | 41 |
| 12.1 | Electrical accessories | 41 |
| 12.2 | Compression fittings for a device with G-internal-threaded connections | 41 |
| 12.3 | Additional software | 41 |
| 13 | Logistics | 42 |
| 13.1 | Transport and storage | 42 |
| 13.2 | Return | 42 |
| 13.3 | Disposal | 42 |

1 About this document

The document is an important part of the product and guides the user to safe installation and operation. The information and instructions in this document are binding for the use of the product.

- ▶ Before using the product for the first time, read and observe the whole safety chapter.
- ▶ Before starting any work on the product, read and observe the respective sections of the document.
- ▶ Keep the document available for reference and give it to the next user.
- ▶ Contact the Bürkert sales office for any questions.



Further information concerning the product at [Products](#).

- ▶ Enter the article number from the type label in the search bar.

The illustrations in these instructions may vary depending on the product variant.

1.1 Symbols



DANGER!

Warns of a danger that leads to death or serious injuries.



WARNING!

Warns of a danger that can lead to death or serious injuries.



CAUTION!

Warns of a danger that can lead to minor injuries.

NOTICE!

Warns of property damage on the product or the installation.



Indicates important additional information, tips and recommendations.



Refers to information in this document or in other documents.

- ▶ Indicates a step to be carried out.

✓ Indicates a result.

Menu Indicates a software user-interface text.

1.2 Terms and abbreviations

The terms and abbreviations are used in this document to refer to following definitions.

| | |
|--------------|---|
| Device | Type 8743 |
| MFC | Mass flow controller |
| bar, bar (g) | Unit for relative pressure |
| bar abs | Unit for absolute pressure |
| Ex area | Potentially explosive atmosphere |
| Ex approval | Approval for potentially explosive atmosphere |

1.3 Manufacturer

Bürkert SAS

20, rue du Giessen

67220 TRIEMBACH-AU VAL

FRANCE

The contact addresses are available at [Contact](#).



Need more information or additional products?

► Explore the full range of products on our [eShop](#).

2 Safety

2.1 Intended use

The device MFC is designed to measure and regulate the mass flow rate of clean and dry gases.

The permitted media are listed in [Technical data \[▶ 15\]](#).

Prerequisites for safe and trouble-free operation are proper transport, storage, installation, commissioning, operation and maintenance.

The instructions are part of the device. The device is intended exclusively for use within the scope of these instructions. Uses of the device that are not described in these instructions, the contractual documents or the type label can lead to severe personal injury or death, damage to the device or property and dangers for the surrounding area or the environment.

- ▶ Only trained and qualified personnel may install, operate and maintain the device. See qualification of persons in [Safety instructions \[▶ 7\]](#)
- ▶ Use the device only in conjunction with third-party devices and components recommended and authorized by Bürkert.
- ▶ Use the device only when it is in perfect condition.
- ▶ Only use the device indoors.
- ▶ Only use devices that are approved for this type of potentially explosive atmosphere. These devices are labelled with the ATEX label on the type label. When using, always observe the details on the type label and the instructions for the potentially explosive atmosphere included in the scope of delivery for the device.
- ▶ Do not open the device.
- ▶ Do not use the device in high-vibration areas.

2.2 Safety instructions

Qualification of personnel working with the device

Improper use of the device can lead to serious personal injury or death. To avoid accidents when working with the device, the following minimum requirements must be met:

- ▶ Carry out work on the device within the scope of these instructions in a safety-compliant manner.
- ▶ Detect and avoid dangers when working on the device.
- ▶ Understand the instructions and implement the information contained therein accordingly.

Responsibility of the operator

The operator is responsible for observing the location-specific safety regulations, also in relation to personnel.

- ▶ Observe the general rules of technology.
- ▶ Install the device according to the regulations applicable in the respective country.
- ▶ The operator must make hazards arising from the location of the device avoidable by providing appropriate operating instructions.

Electrostatically sensitive components and assemblies

The device contains electronic components that are susceptible to the effects of electrostatic discharging (ESD). Components that come into contact with electrostatically charged persons or objects are at risk. In the worst case scenario, these components will be destroyed immediately or fail after start-up.

- ▶ Meet the requirements specified by EN 61340-5-1 to minimise or avoid the possibility of damage caused by a sudden electrostatic discharge.
- ▶ Do not touch electronic components when the supply voltage is connected.

Electric shock due to electrical components

Touching live parts can result in severe electric shock. This can lead to serious personal injury or death.

- ▶ Before working on the device or system, switch off the power supply. Secure it against reactivation.
- ▶ Observe any applicable accident prevention and safety regulations for electrical devices.

Changes and other modifications, spare parts and accessories

Changes to the device, incorrect installation or use of non-approved devices or components create hazards that can lead to accidents and injuries.

- ▶ Do not make any changes to the device.
- ▶ Do not mechanically load the device.
- ▶ Observe the operating instructions of the device or component used.
- ▶ Only use the devices in conjunction with devices and components recommended or approved by Bürkert.

Spare parts and accessories that do not meet Bürkert's requirements may impair the operational safety of the device and cause accidents.

- ▶ To ensure operational safety, only use original parts from Bürkert.

Operation only after proper transport, storage, installation, commissioning, or maintenance

Improper transport, storage, installation, commissioning, or maintenance jeopardises the operational safety of the device and can cause accidents. This can lead to serious personal injury or death.

- ▶ Observe all values and limits specified in these instructions to ensure the device's safety and functionality.
- ▶ Only carry out work described in these instructions.
- ▶ Only carry out work using suitable tools.
- ▶ All other work must be carried out by Bürkert only.

Working on the device

Working on the device that has not been powered down, unauthorised switching on or uncontrolled start-up of the system can cause accidents. This can lead to serious personal injury or death.

- ▶ Only work on the device when it is not in use.
- ▶ Ensure that the device or system cannot be switched on unintentionally.

- ▶ Only start the process in a controlled manner following disruptions. Observe sequence:
 1. Apply supply voltage or pneumatic supply.
 2. Charge the device with medium.

Technical limit values and media

Non-compliance with technical limit values or unsuitable media can damage the device and lead to leaks. This can cause accidents and seriously injure or kill people.

- ▶ Comply with limit values. See **Technical data** [▶ 15] and information on the type label.
- ▶ Only feed media into the media ports that are listed in the chapter **Technical data** [▶ 15].
- ▶ Observe the safety data sheet for the media used.

Only use authorised devices in potentially explosive atmospheres

Devices that may be used in potentially explosive atmospheres are labelled with an Ex marking. Additional instructions with Ex labelling are included with these devices.

- ▶ Only use devices that are approved for use in a potentially explosive atmosphere.
- ▶ For use in potentially explosive atmospheres, observe the information on the device.
- ▶ For use in potentially explosive atmospheres, observe the additional instructions with Ex labelling.
- ▶ Do not use devices that do not have this Ex labelling and additional instructions in potentially explosive atmospheres under any circumstances.

Medium under pressure

Medium under pressure can seriously injure people. In the event of overpressure or pressure surges, the device or lines can burst. Pneumatic lines that are defective or not securely fastened can come loose and swing around.

- ▶ Before working on the device or system, switch off the pressure. Vent or empty the lines.
- ▶ Adhere to the permitted pressure ranges of the medium.
- ▶ Comply with the permitted temperature ranges of the medium.

Hot surfaces and fire hazard

The surface of the device can become hot with fast-switching actuators or with hot media.

- ▶ Wear suitable protective gloves.
- ▶ Keep highly flammable substances and media away from the device.

3 Product description

3.1 Product overview

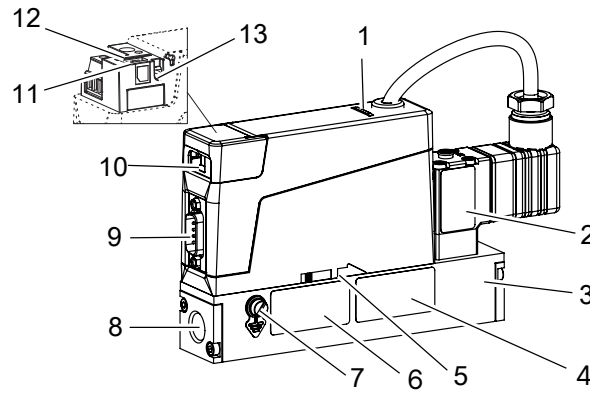

Fig. 1: Example of a variant

| | |
|-------------------------------|-------------------------|
| 1 Status indicator | 2 Proportional valve |
| 3 Base block | 4 Calibration label |
| 5 Flow direction marking | 6 Type label |
| 7 Functional earth connection | 8 Medium connection |
| 9 Electrical connection | 10 Not used |
| 11 bus interface | 12 Slot for memory card |
| 13 Not used | |

3.2 Product identification

3.2.1 Type label

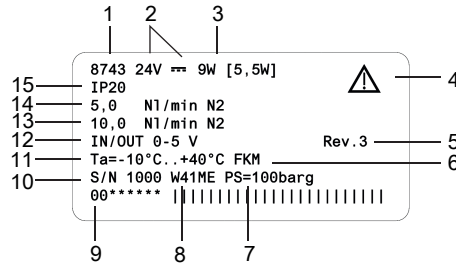

Fig. 2: Example of type label Type 8743

| | |
|---|---|
| 1 Type | 2 Operating voltage |
| 3 Power consumption | 4 Note: Observe the operating instructions |
| 5 Bürkert internal version | 6 Sealing material |
| 7 Burst pressure | 8 Manufacture code |
| 9 Article number | 10 Serial number |
| 11 Ambient temperature | 12 Protocol |
| 13 Nominal mass flow rate (Q nominal), unit and operating gas 2 | 14 Nominal mass flow rate (Q nominal), unit and operating gas 1 |
| 15 Degree of protection | |

3.2.2 Calibration label

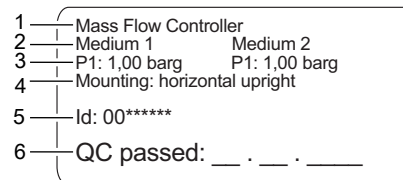

Fig. 3: Example of calibration label

| | |
|------------------------|-------------------------|
| 1 Variant | 2 Calibration medium |
| 3 Calibration pressure | 4 Installation position |
| 5 Article number | 6 Calibration date |

3.2.3 Conformity marking

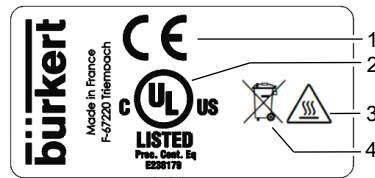

Fig. 4: Conformity label

| | |
|------------------------|---|
| 1 CE marking | 2 Certification marking for USA and/or Canada |
| 3 Warning: hot surface | 4 Indication for disposal |

3.2.4 Symbols and markings on device



Earth terminal



Direct current

3.3 Display elements

3.3.1 Status indicator

The status indicator changes its colour based on the NAMUR recommendation NE 107. Refer to [NAMUR mode \[▶ 12\]](#).

The colour of the status indicator indicates:

- Whether device diagnostics are active or not. Diagnostics are active on the device and cannot be deactivated.
- If diagnostics are active, then the status indicator shows whether diagnostics events have been generated or not. If several diagnostics events have been generated, then the status indicator shows the diagnostics event with the highest priority.

If the status indicator flashes, then the device is selected in a man-machine interface such as the Bürkert Communicator software.

- ▶ To solve a problem indicated by the status indicator, refer to [Troubleshooting \[▶ 35\]](#)

3.3.2 NAMUR mode

The status indicator shows the status of the device and its peripherals, based on NAMUR recommendation 107 (NE 107).

If various alerts are present, the status indicator always shines in the colour of the highest prioritised alert (red = outage = highest priority).

| Colour | Colour code | Status signal | Description |
|--------|-------------|----------------------|---|
| Red | 5 | Failure | Due to a malfunction in the device or its periphery, normal operation is not possible. |
| Orange | 4 | Check function | Work is being carried out on the device, which means that normal operation is temporarily not possible. |
| Yellow | 3 | Out of specification | The environmental or process conditions for the device are outside the specified range. Internal device diagnosis indicate problems in the device or process characteristics. |
| blue | 2 | Maintenance required | The device is in normal operation, although a function is briefly restricted. ▶ Service device |
| Green | 1 | Diagnosis active | Device is running faultlessly, diagnosis are active. |
| White | 0 | Diagnosis passive | Device is switched on, diagnosis are inactive. |

Tab. 1: Status indicator according to NE 107

3.4 Functionality

3.4.1 Service-büS interface

The Service-büS interface is used for short-term servicing of the device with the Bürkert Communicator.

The Bürkert Communicator runs under Windows. Refer to [Connect to the Bürkert Communicator](#) [▶ 26]

The USB-büS-Interface set, available as an accessory, is necessary. Refer to [Spare parts and accessories](#) [▶ 41]

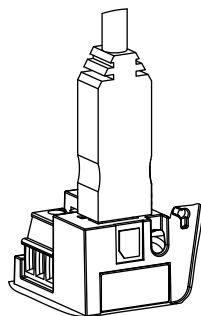

Fig. 5: büS stick, inserted in the related connector of the device

3.4.2 Control valve

The control valve is a direct-acting and normally-closed proportional valve.

The control valve provides the sealing function when the following conditions are met:

- The device is used within the specified pressure range.
- The device is equipped with a valve seat seal that is made of a soft material such as FKM, FFKM or EPDM.



If the valve seat seal is made of a hard material such as PCTFE, then the control valve may not be tight.

Valves with a seat size of 0.05 mm or 0.1 mm have a seat seal made of a hard material.

Unstable measured values may occur. Refer to [Unstable measured value \[▶ 38\]](#)

3.4.3 Memory card



If the memory card is defective or has been lost, contact the Bürkert sales office to purchase a new one.

The device can be delivered with a memory card that is inserted in the device. When the device is energised, there are two possibilities:

- If the inserted memory card contains device-specific data, the device automatically adopts this data. At the time of delivery, the memory card is preloaded with device-specific information. To view the stored data, refer to the file Device Description File.
- If the inserted memory card is empty, the device saves its own data onto the card. A new memory card is empty.

To download the file Device Description File:

- ▶ Access the page [Type 8743](#)
- ▶ Scroll down to **Downloads > Software**

The data stored on the memory card can be transferred to another device with the same article number. For example, data from a defective device can be transferred to a replacement device.

4 Technical data

4.1 Standards and directives

This product complies with the legal requirements applicable at the time of placing on the market and has been developed and tested in accordance with the relevant European directives/regulations and harmonized standards. The conformity is documented and, if necessary, supported by evidence. The EU Declaration of Conformity can be found behind the respective type on the home page country.burkert.com

4.2 Operating conditions

| | |
|---|--|
| Ambient temperature | -10...+40 °C |
| Storage temperature | -10...+70 °C |
| Degree of protection (EN 60529 / IEC 60529) | IP20 ¹⁾ |
| Medium temperature | -10...+50 °C |
| Medium | Refer to the type label Clean and dry. Quality classes according to DIN ISO 8573-1. |
| Operating pressure | max. 10 bar (g) |
| Relative ambient humidity | Max. 95% at 55 °C (non-condensing) |

4.3 Medium data

| | |
|--|--|
| Calibration medium | Nitrogen (N ₂) |
| Nominal flow range Q_{nom} (reference to N ₂ (I _N /min)) | 0.01...100 I _N /min |
| Turndown ratio | 1:20 ($Q_{nom} < 0,025 I_N/min$) 1:50 ($Q_{nom} \geq 0,025 I_N/min$) others on request |
| Repeatability | ±0.1% of the full scale |
| Measurement accuracy, after 30 minutes warm-up time | ±0.8% of the measured value ±0.3% of the full scale If the medium deviates from the calibration medium, the actual measurement accuracy might vary from the value specified in the data sheet. |
| Response time | < 2 s |

¹⁾ When cables or plugs and sockets are connected correctly, verified by Bürkert, not evaluated by UL.

Quality of the medium

NOTICE!

The medium must obey the quality criteria to obey the following requirements:

- ▶ the necessary measurement accuracy of the device
- ▶ to meet the safety requirements
- ▶ to meet the closed-loop control accuracy of an MFC

✓ For further information on the quality criteria, refer to ISO 8573-1.

| Criteria | Quality class | Value |
|----------------------------------|---------------|------------------------|
| Maximum particle size | 2 | 1 µm |
| Maximum particle density | 2 | 1 mg/m ³ |
| Maximum dew point under pressure | 4 | 3 °C |
| Maximum oil concentration | 1 | 0.01 mg/m ³ |

Tab. 2: Quality criteria of the medium, ISO 8573-1, Compressed Air - Part 1: Contaminants and purity classes

4.4 Electrical data

| | |
|--|--|
| Operating voltage | 24 V $\overline{=}$ $\pm 10\%$ residual ripple < 2 % |
| Power consumption | Refer to type label |
| Analogue input for the measured value 0/4...20 mA | Maximum input impedance: 200 Ω Resolution: 5 μ A |
| Analogue input for the measured value 0...5/10 V | Minimum input impedance: 20 k Ω Resolution: 2,5 mV |
| Analogue output for the measured value 0/4...20 mA | Maximum loop impedance: 400 Ω at an operating voltage of 24 V $\overline{=}$ Resolution: 20 μ A |
| Analogue output for the measured value 0...5/10 V | Maximum current: 20 mA Resolution: 10 mV |
| Digital input | <ul style="list-style-type: none"> • 0...0.2 V to activate level 1 • 1...4 V or open to activate level 2 • 5...28 V to activate level 3 |
| Relay output type | Normally closed contact (break contact), free of potential |
| Maximum ratings | 1 A, 30 V, 30 VA |
| Electrical connections | <ul style="list-style-type: none"> • 6-pin terminal strip, pitch 5.0 mm • D-sub DE-9 plug • service bÜS interface |
| Minimum temperature rating of the cable to be connected to the field wiring terminals: | 75 °C |

4.5 Mechanical data

| | |
|----------------------------------|---|
| Housing | Polycarbonate (PC) |
| Status indicator | Polycarbonate |
| Parts in contact with the medium | Stainless steel 316 (1.4401), 316L (1.4404, 1.4435), PCTFE, Seal (Refer to the type label) Valve: 1.4310, 1.4113, 1.4305 |

5 Medium connection



Risk of injury or material damage when working on the device or system.

- ▶ Read and observe the chapter [Safety \[▶ 7\]](#) before working on the device or system.

5.1 Possible medium connections

- G-internal-threaded connections according to DIN ISO228/1
- NPT-internal-threaded connections according to ASME/ ANSI B 1.20.1
- Flange connection
- Connections with external-threaded vacuum fittings
- Connections with external-threaded compression fittings
- Tri-Clamp

5.2 Installation procedure



WARNING!

Risk of injury that is due to leakage.

At a low mass flow rate and a high pressure, make sure that the installation is tight. The tightness prevents incorrect measurements or leakage of the medium.

To make sure that the installation is tight, observe the following instructions:

- ▶ Use compression fittings. Mount the compression fittings in a way that they are not subject to any stresses.
- ▶ Use pipes with diameter that is adapted to the medium connection of the device, and a smooth surface.

NOTICE!

Malfunction that is due to contamination.

If a contaminated medium is used, then install a filter upstream of the device. The filter mesh-size must be smaller than 25 µm. The filter ensures problem-free functioning of the device.

5.2.1 G1/8"-internal-threaded connections

- ▶ Remove the protective cap that closes the threaded connection.
- ▶ Do the medium connection on one side of the device.
- ▶ Obey the instructions that are given by the manufacturer of the fitting used.
- ▶ Obey the torques that are given by the manufacturer of the fitting used.
- ▶ Do the medium connection on the other side of the device in the same way.

5.2.2 NPT1/8"-internal-threaded connections

- ▶ Do the medium connection on one side of the device.

- ▶ Obey the instructions that are given by the manufacturer of the fitting used.
- ▶ Obey the torques that are given by the manufacturer of the fitting used.
- ▶ Do the medium connection on the other side of the device in the same way.

5.2.3 Flange connections

A variant with flange connections is mounted on a process connection plate by the manufacturer.

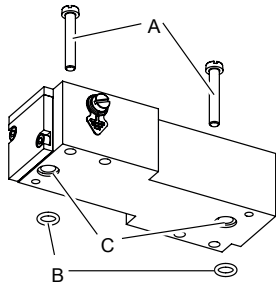

- ▶ Use the M4 screws [A] and O-ring sealings [B] delivered with the device.
- ▶ Place the O-ring sealings in the cavity [C] of the base block.
- ▶ Tighten the screws to a torque of 2,7...2,9 N·m (1,99...2,14 lbf·ft).

Fig. 6: Flange connection with screws and O-ring sealings

5.2.4 Connections with external-threaded vacuum fittings

- ▶ Remove the protective cap that closes the connection.
- ▶ Do the medium connection on one side of the device.
- ▶ Obey the instructions that are given by the manufacturer of the fitting used.
- ▶ **CAUTION! To avoid damage on the sealing of the medium connection, please make sure to lock the hexagonal part in place with a second wrench.**
Obey the torques that are given by the manufacturer of the fitting used.
- ▶ Do the medium connection on the other side of the device in the same way.

5.2.5 Connections with external-threaded compression fittings

- ▶ Do the medium connection on one side of the device.
- ▶ Obey the instructions that are given by the manufacturer of the fitting used.
- ▶ **CAUTION! To avoid damage on the sealing of the medium connection, please make sure to lock the hexagonal part in place with a second wrench.**
Obey the torques that are given by the manufacturer of the fitting used.
- ▶ Do the medium connection on the other side of the device in the same way.

5.2.6 Tri-clamp connections

- ▶ Remove the protective cap that closes the threaded connection.
- ▶ Do the medium connection on one side of the device.
- ▶ Obey the instructions that are given by the manufacturer of the fitting used.
- ▶ Do the medium connection on the other side of the device in the same way.

6 Electrical connection



Risk of injury or material damage when working on the device or system.

- ▶ Read and observe the chapter [Safety \[▶ 7\]](#) before working on the device or system.

6.1 Additional documentation

Further documentation concerning the product:

- ▶ Access the page [Type 8743](#)
- ▶ Scroll down to **Downloads**
- ▶ Or enter the article number from the type label in the search bar.

6.2 Wire the variant Analogue with D-sub DE-9 male connector

NOTICE!

Requirements for the correct operation of the device.

- ▶ Use a power supply unit with sufficient power.
- ▶ Use shielded cables only.
- ▶ Connect each cable end to the functional earth.
- ▶ For an MFC pay attention to the maximum permissible residual ripple on the operating voltage (residual ripple < 2 %).

NOTICE!

UL approved versions must be supplied in one of the following ways:

- ▶ "Limited Energy Circuit" (LEC), according to UL / IEC61010-1
- ▶ "Limited Power Source" (LPS), according to UL / IEC60950
- ▶ SELV / PELV with UL-approved overcurrent protection, designed according to UL / IEC61010-1, Table 18 (e.g. Block PM-0124-020-0)
- ▶ NEC Class 2 power supply unit



The cable shield is connected by the housing of the D-sub DE-9 male connector.

| D-sub DE-9 male connector | Pin | Assignment |
|---------------------------|-----|--|
| | 1 | Digital input |
| | 2 | GND for the digital input and the power supply |
| | 3 | +24 V \equiv |
| | 4 | Relay: normally closed contact (Break contact) |
| | 5 | Relay: reference contact |
| | 6 | Set-point input |
| | 7 | GND for the set-point input |
| | 8 | Analogue output for the measured value |
| | 9 | GND for the analogue output |
| Housing | | FE |

Tab. 3: Pin assignment of the D-sub DE-9 male of the device

- ▶ Wire a D-sub DE-9 female connector according to the pin assignment.
- ▶ Connect the D-sub DE-9 female connector to the D-sub DE-9 male connector.
- ▶ Tighten the screws to a torque of 0,5...0,6 N·m (0,37...0,44 lbf·ft).
- ▶ Connect the functional earthing of the device. Refer to [Connect the functional earth \[▶ 24\]](#)

6.2.1 Digital input

The D-sub DE-9 male connector has a digital input. A digital input is used to remotely trigger a function.

Available functions

- Start the function autotune.
- Trigger the remote control of the actuator or trigger the control of the actuator by the device.
- Reset the totalizer for the active gas.
- Select which gas is active among 3 gases.
- Select the set-point value.

Default assignment

Start autotune

- ▶ To select the function to be remotely triggered over the digital input, use the Bürkert Communicator. Only one of the available functions can be associated to the digital input.

A function has up to 3 possible switching levels which may trigger different actions. The following table gives the actions that are associated to the switching levels, and how each level is activated.

Digital input 1 inverted

| Function | Level 1 "low" ²⁾ | Level 2 "open" ³⁾ | Level 3 "high" ⁴⁾ |
|---|----------------------------------|------------------------------|---------------------------------|
| Start autotune | Starts Autotune | - | - |
| Set-point value source | Triggers Stored set-point active | - | Triggers Open-loop control mode |
| Reset totalizer | Resets the Totalizer | - | - |
| Gas selection for 2 gases | Switches to gas 2 | Switches to gas 1 | Switches to gas 1 |
| Gas selection for 3 gases ⁵⁾ | Switches to gas 2 | Switches to gas 1 | Switches to gas 3 |
| Actuator control | Opens the actuator completely | - | Closes the actuator |
| Close actuator | Closes the actuator | - | - |

Tab. 4: Actions triggered by the switching levels

Digital input 1 not inverted

| Function | Level 1 "low" ²⁾ | Level 2 "open" ³⁾ | Level 3 "high" ⁴⁾ |
|---|---------------------------------|------------------------------|----------------------------------|
| Start autotune | - | - | Starts Autotune |
| Set-point value source | Triggers Open-loop control mode | - | Triggers Stored set-point active |
| Reset totalizer | - | - | Resets the Totalizer |
| Gas selection for 2 gases | Switches to gas 1 | Switches to gas 1 | Switches to gas 2 |
| Gas selection for 3 gases ⁵⁾ | Switches to gas 3 | Switches to gas 1 | Switches to gas 2 |
| Actuator control | Closes the actuator | - | Opens the actuator completely |
| Close actuator | - | Closes the actuator | Closes the actuator |

Tab. 5: Actions triggered by the switching levels

6.2.2 Relay output

The D-sub DE-9 male connector has a relay output.

- 2) Digital input is connected to GND
- 3) Digital input is not connected (alternatively: 1..4 V $\overline{\text{---}}$)
- 4) Digital input is connected to +24 V $\overline{\text{---}}$ (alternatively: 5...28 V $\overline{\text{---}}$)
- 5) Not possible to select the 4th gas curve

The relay switching can show the following events:

- A warning message has been generated. For example if the supply voltage is too high, then a warning message is generated.
- A failure message has been generated. For example if a sensor failure is detected, then a failure message is generated.
- The set-point value cannot be reached.
- The device is doing an Autotune.
- The **Set-point value source** has changed.

Default assignment

The set-point value cannot be reached

- ▶ To choose the events that are assigned to the relay output, use the Bürkert Communicator. Several events can be associated to the relay output.

6.3 Wire the variant Analogue with a 6-pin terminal strip

NOTICE!

Requirements for the correct operation of the device.

- ▶ Use a power supply unit with sufficient power.
- ▶ Use shielded cables only.
- ▶ Connect each cable end to the functional earth.
- ▶ For an MFC pay attention to the maximum permissible residual ripple on the operating voltage (residual ripple < 2 %).

NOTICE!

UL approved versions must be supplied in one of the following ways:

- ▶ "Limited Energy Circuit" (LEC), according to UL / IEC61010-1
- ▶ "Limited Power Source" (LPS), according to UL / IEC60950
- ▶ SELV / PELV with UL-approved overcurrent protection, designed according to UL / IEC61010-1, Table 18 (e.g. Block PM-0124-020-0)
- ▶ NEC Class 2 power supply unit

| 6-pin terminal strip | Pin | Assignment |
|----------------------|-----|----------------------------------|
| | 1 | +24 V \equiv |
| | 2 | GND |
| | 3 | Set-point analogue input + |
| | 4 | Set-point analogue input GND |
| | 5 | Actual value analogue output + |
| | 6 | Actual value analogue output GND |

Tab. 6: Pin assignment of the 6-pin terminal strip of the device

- ▶ Connect the conductors.
- ▶ Tighten the screws at a torque between 0,5...0,6 N·m (0,37...0,44 lbf·ft).
- ▶ Earth the device. Refer to [Connect the functional earth \[▶ 24\]](#)

6.4 Connect the functional earth



WARNING!

Risk of ignition and risk of fire that are due to electrostatic discharge.

An electrostatic discharge of the device can ignite combustible gas vapours.

- ▶ To avoid a build up of electrostatic charge, connect the housing to the functional earth.
- ▶ If the functional earth is not attached, then the requirements of the EMC directive are not met.

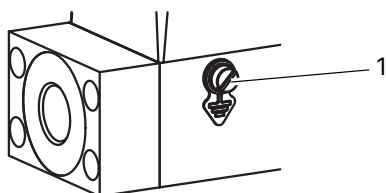

Fig. 7: Location of the M4 screw for the connection of the functional earth

1 M4 screw

- ▶ Use a green-and-yellow cable that is as short as possible. And the cable cross-section must be at least equal to the cross section of the power-supply cable.
- ▶ With a flat screwdriver of size 6.5 mm, loosen the M4 screw.
- ▶ Attach the green-and-yellow cable to the M4 screw with a cable lug.
- ▶ Tighten the M4 screw to a torque of 1,8 N·m...2 N·m (1,33 lbf·ft...1,47 lbf·ft).

7 Commissioning



Risk of injury or material damage when working on the device or system.

- ▶ Read and observe the chapter [Safety \[▶ 7\]](#) before working on the device or system.
-

7.1 Commissioning procedure

- ▶ Pressurise the pipes with medium.
- ▶ Flush the pipes with medium at the calibration pressure.
- ▶ Vent the pipes completely.
- ▶ Check if the memory card is inserted.
- ▶ Energise the device.
- ▶ If the device is an MFC, and the medium is not the calibration medium or the pressure conditions have changed, then run the Autotune function. Refer to [Optimise the closed-loop control parameters \[▶ 31\]](#)
- ✓ The device operates normally.

8 Configuration with Bürkert Communicator

8.1 Setting tools



The MassFlowCommunicator is another PC software that is not compatible with the device. The MassFlowCommunicator software cannot be used to configure or operate the device.

Settings can be made with the Type 8920 Bürkert Communicator. For general information about the Bürkert Communicator, refer to the operating instructions of Type 8920.

- ▶ Access the page [Type 8920](#)
- ▶ Scroll down to **Downloads** > **User Manuals**

8.2 Connect to the Bürkert Communicator

- ▶ Use the USB-büS-Interface set, article number 00772551.
- ▶ Download the latest version of the Type 8920 Bürkert Communicator.
- ▶ Access the page [Type 8920](#)
- ▶ Scroll down to **Downloads** > **Software**
- ▶ Install the Bürkert Communicator on a PC. During installation, the büS stick must not be connected to the PC.
- ▶ Assemble the parts of the USB-büS-Interface set.



Fig. 8: Assembled parts of the USB-büS-Interface set

- ▶ Set the termination-resistance switch of the büS stick to ON.
- ▶ Insert the büS stick into a USB port of the PC.
- ▶ Energise the device. Refer to [Electrical connection \[▶ 20\]](#)
- ▶ Insert the micro-USB connector into the büS interface of the device. Refer to [Product description \[▶ 10\]](#)
- ▶ Wait until the driver of the büS stick has been completely installed on the PC.
- ▶ Start the Bürkert Communicator.
- ▶ Click on  in the Bürkert Communicator to establish the communication with the device.
 - ✓ A window opens.
- ▶ Select **Connect via USB (büS Stick)**.

- ▶ Select the port Bürkert USB büS stick, click on **Finish** and wait until the device symbol appears in the list of devices.
- ▶ In the navigation area, click on the symbol related to the device: The device menu appears.

8.3 Functions

8.3.1 Shut-Off threshold for the valve

A shut-Off threshold ensures the sealing function of the control valve (except valve with PCTFE seat sealing). If the used set-point value is below the shut-off threshold, the control signal for the valve is set to 0% immediately.

8.3.2 Cut-Off threshold for actual flow

A cut-off threshold for the actual flow is calculated from the nominal flow, the measuring span and a calculation factor. Measured values below the calculated cut-off threshold will be displayed as zero actual flow.

8.4 Change of medium

With the Bürkert Communicator, it is possible to change the medium by using a LUA-Script which can be downloaded at country.burkert.com.

To perform the LUA-Script:

- ▶ Connect the device to the Bürkert Communicator software. Refer to [Connect to the Bürkert Communicator \[▶ 26\]](#)
- ▶ Select the device.
- ▶ Go to **File > Scripts**.
- ▶ Browse the downloaded zip-File.

✓ The procedure of changing medium starts.

8.5 User-defined adjustment

At delivery the device is calibrated by the manufacturer.

With the Bürkert Communicator, it is possible to define an adjustment procedure with up to 32 calibration points.

This procedure is described in device specific **Documents and tools** in the Bürkert Communicator.

- ▶ Connect the device to the Bürkert Communicator. Refer to [Connect to the Bürkert Communicator \[▶ 26\]](#)

8.6 Zero point adjustment

It is possible to perform a zero point adjustment procedure to adapt the sensor characteristic curve to the current conditions (mounting/installation position, medium, operating pressure). The device will be calibrated in installation position in any case. It is possible to use another installation position. Afterwards a zero point adjustment procedure is necessary.

- ▶ Start the communication with the Bürkert Communicator. Refer to [Connect to the Bürkert Communicator \[▶ 26\]](#)
- ▶ Choose the device.
- ▶ Select **Sensor > Diagnostics > Start zero point adjustment**
- ✓ The procedure starts.
- ✓ The device switches the namur status to orange.

8.7 Set-point value sources and operation modes

Different sources can set the process set-point value. Select one active source at a time.

Change the set-point value source during operation if required. Changing the set-point value source also changes the device operating mode.

When energising the device for the first time, the device enters a short initialisation phase and then switches to the normal operation mode.

- ▶ Connect the device to the Bürkert Communicator. Refer to [Connect to the Bürkert Communicator \[▶ 26\]](#).
- ▶ Select the device.
- ▶ Go to **Controller > Parameter > Set-point value > Set-point value source**.



The **Set-point value source** remains after a restart. It resets only when the selected source is **Manual set-point value** or **Analyze system**.

| Set-point value source | Description | Operation mode |
|-------------------------------|---|-------------------------------------|
| Analog set-point value source | The analogue input sets the set-point value | Normal operation mode (Closed Loop) |
| Manual set-point value | For testing or to prevent overwriting by other fieldbus participants. | Normal operation mode (Closed Loop) |
| Stored setpoint | To use a fixed set-point value (w). After a device restart, the fixed set-point value remains active. | Normal operation mode (Closed Loop) |
| Open-loop control mode | To directly set the position set-point value (y) to the actuator. The menu Actuator > Parameter > Actuating variable provides the used position set-point value (y). Restarting the device sets the position set-point value (y) to zero. | Open-loop control mode |
| Analyze system | The device operates in normal operation mode according to a predefined chronological sequence of set-point values. Use the resulting diagram with the graphical process values to analyse the system with the Bürkert Communicator. | Analyse the system |

Tab. 7: Set-point value sources and operation modes

8.8 Operation modes

When energising the device for the first time, the device enters a short initialisation phase and then switches to the normal operation mode. Refer to [Normal operation mode \[▶ 29\]](#)

- ▶ To change the operation mode, change the source for the set-point values. Refer to [Select the source that gives the set-point value \[▶ 31\]](#)

The operation mode is kept after a device restart, except when the device performs the function **Analyze system**.

8.9 Normal operation mode

The normal operation mode is active when energising the device for the first time.



If the valve seat seal is made of a hard material such as PCTFE, then the control valve may not be tight.

Valves with a seat size of 0.05 mm or 0.1 mm have a seat seal made of a hard material.

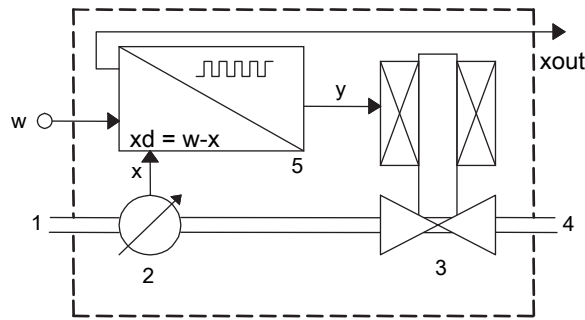

Fig. 9: Function diagram of the MFC with control valve

| | |
|-----------------------------------|---|
| 1 Medium inlet | 2 Sensor |
| 3 Control valve | 4 Medium outlet |
| 5 Electronics | x measured value of the mass flow rate |
| y set-point position of the valve | w set-point value of the mass flow rate |

The sensor measures the mass flow rate and compares the measured value x with the set-point value w . The device calculates the set-point position value y of the actuator.

- The set-point position value y determines the opening of the control valve. For example, if the set-point position value y is equal to 10%, then the opening of the control valve is 10%.

The transmission means of the set-point value w and the measured value of the flow rate depends on the device.

- ▶ If the operating conditions have changed, then optimise the closed-loop control parameters. Refer to [Optimise the closed-loop control parameters \[▶ 31\]](#)
- ▶ To change the operation mode, change the source for the set-point value. Refer to [Select the source that gives the set-point value \[▶ 31\]](#)

8.9.1 Analogue variant

After applying the operating voltage, the device enters a short initialisation phase and then switches to the normal operation mode. The normal operation mode of a variant Analogue is the **Analog setpoint** operation mode.

- The set-point value w is transmitted over the set-point analogue input according to the ranges in the following table.
- The measured value of the flow rate is transmitted over the analogue output according to the ranges in the following table.

| Analogue output range | Minimum value of the input ranges and output ranges | Maximum value of the input ranges and output ranges |
|-----------------------|---|---|
| 4...20 mA | 4 mA, $w = 0\%$ | 20 mA, $w = 100\%$ |
| 0...20 mA | 0 mA, $w = 0\%$ | 20 mA, $w = 100\%$ |
| 0...5 V \equiv | 0 V, $w = 0\%$ | 5 V, $w = 100\%$ |
| 0...10 V \equiv | 0 V, $w = 0\%$ | 10 V, $w = 100\%$ |

Tab. 8: Analogue-input ranges and analogue-output ranges

8.10 Optimise the closed-loop control parameters

The closed-loop control parameters of the device can be optimised for the current operating conditions with a function that is called Autotune.

- Run the Autotune function when the device is started for the first time.
- If the operating conditions have changed, then run the Autotune function.

If the device detects that the pipe is empty, then the Autotune function cannot be started.

When the Autotune is running:

- ▶ Do not interrupt the power supply to the device.
- ▶ Keep the supply pressure constant.



WARNING!

Risk of injury from flowing medium.

While the Autotune function is running, the mass flow rate value can be higher than the nominal flow rate value.

- ▶ Before running the Autotune function, make sure that no danger can occur if the mass flow rate value increases.
- ▶ Trigger the Autotune function with one of the following means:
 - ▶ over the digital input
 - ▶ with the Bürkert Communicator. Refer to [Connect to the Bürkert Communicator \[▶ 26\]](#)
- ✓ The Autotune runs and the status indicator is orange.
- ✓ A zero-point adjustment will be performed at the beginning of the autotune function.
- ✓ The device temporarily stops regulating the flow rate in the pipe.
- ✓ When the function is completed, the device returns to its previous operating mode.
- ✓ If the function is completed successfully, then the optimised closed-loop control parameters are transferred to the hard memory of the device.

8.11 Select the source that gives the set-point value

The process set-point value can be set by different sources. It is possible to select which source is active at a time. The source for the set-point value can be changed during operation.

If the source for the set-point value is changed, then the operation mode of the device is changed.

To change the source for the set-point value, change the setting of the parameter **Set-point value source** with the Bürkert Communicator. Refer to [Connect to the Bürkert Communicator \[▶ 26\]](#)



The setting of the parameter **Set-point value source** is kept after a restart, except when the device performs the function **Analyze system** or the set-point value source was set to manual set-point.

It is possible to alternatively change the related object. Refer to the file Device Description File.

- ▶ Access the page [Type 8743](#)
- ▶ Scroll down to **Downloads > Software**

Possible choices for the parameter **Set-point value source**

| | |
|--------------------------------------|--|
| Analog set-point value source | The setpoint value is set via the analogue input. |
| Manual set-point value | To manually give in a set-point value for testing purposes or to make sure that the set-point value is not overwritten by other fieldbus participants. |
| Stored setpoint | To use a fixed set-point value (w). If the device is restarted, then the fixed set-point value remains active. Refer to Normal operation mode [▶ 29] |
| Open-loop control mode | To directly set the set-point position (y) to the actuator. The value that is given in the menu Actuator > Parameter > Actuating variable is the setpoint position (y) that is used. A restart of the device sets the set-point position (y) to zero. Refer to Normal operation mode [▶ 29] |
| Analyze system | The device operates in the normal operation mode, but according to a predefined chronological sequence with set-point values. Use the resulting diagram in combination with the graphical representation of process values to analyse the system with the Bürkert Communicator. |

9 Maintenance

If the device is operated according to the Operating instructions, then the device is maintenance-free.



Risk of injury or material damage when working on the device or system.

- ▶ Read and observe the chapter [Safety \[▶ 7\]](#) before working on the device or system.

9.1 Service tasks and intervals

The device is equipped with a stainless steel mesh-filter, which is located in the medium connection. If the device is exposed to a demanding environment or contaminated medium, the filter must be checked regularly. If necessary, the filter can be cleaned.

9.2 Inspect and clean the stainless steel mesh-filter

The inspection and possibly cleaning of the stainless steel meshfilter must be done at regular intervals. The inspection frequency and cleaning frequency depend on the measured medium.

If a contaminated medium is used, then clean the stainless steel mesh-filter immediately. If the stainless steel mesh-filter is contaminated, then replace it with a new one.

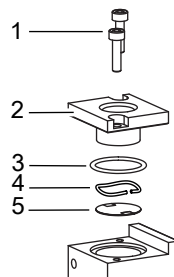

Fig. 10: Parts in contact with the medium

| | |
|-------------------------------|----------------|
| 1 Screws | 2 Flange plate |
| 3 O-ring | 4 Spring |
| 5 Stainless steel mesh-filter | |

- ▶ Position the device upright with the medium inlet at the top.
- ▶ With an hexagon key of size 2.5 mm, loosen the screws [1] and remove the flange plate [2].
- ▶ With a pair of tweezers, remove the O-ring [3], the wave spring [4] and the mesh filter [5].
- ▶ **CAUTION! Do not clean the mesh filter with tap water.** Clean the stainless steel mesh-filter [5] with acetone, isopropanol or compressed air.
- ▶ Dry the mesh filter.
- ▶ **CAUTION! Before mounting the parts back, make sure that the fine side of the mesh filter [5] faces the flange plate [2]**
- ▶ Mount the parts back in the correct order.
- ▶ Make sure that the mesh filter and the O-ring are seated flat and not tilted.

- ▶ Insert the flange plate [2] and the screws [1].
- ▶ Tighten the screws to a torque of 1.2 N·m (0,88 lbf·ft).

9.3 Calibration

The device is factory calibrated.

A regular check of the accuracy depends on the use and the individual requirements of the application. Mechanical wear, ageing of the materials, temperature changes, frequent use or contamination can affect the measuring accuracy over time. It is therefore advisable to calibrate measuring devices regularly to ensure precise measurement results at all times. The customer is responsible for determining the timing of the periodic inspection. We recommend checking the calibration after 12 months. If required, contact [Bürkert](#) for further information on calibrations and to arrange an appointment.



The calibration only applies to the primary measuring function of the measuring device. The secondary outputs are not covered by the calibration.

9.4 Replace the memory card

- ▶ De-energise the device.
- ▶ With tweezers slightly push the memory card to the stop in the device and release. The old memory card comes out.
- ▶ Pay attention to the insertion direction of the memory card.

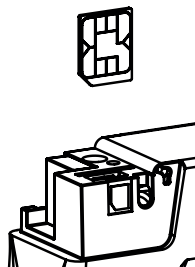

Fig. 11: Insertion direction of the memory card

- ▶ Push the new memory card in the slot until you hear a locking noise. If the memory card comes out, the locking failed.

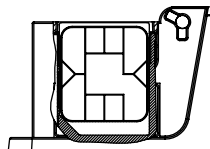

Fig. 12: Inserted memory card

- ▶ Restart the device to write the data on the new memory card. Possible problems related to the memory card are given in [Troubleshooting \[▶ 35\]](#)

10 Troubleshooting

10.1 Status indicator is red

| Cause | Solution |
|---|--|
| The supply voltage is out of the error range. The device can be damaged. | <ul style="list-style-type: none"> ▶ Operate the device within the specifications. <p>If the status indicator does not change, then send the device back to Bürkert.</p> |
| The sensor, the internal memory or the device is defective. | <p>Maintenance is needed.</p> <ul style="list-style-type: none"> ▶ Contact the manufacturer. |
| The device has been operated outside the temperature limits. The device can be damaged. | <ul style="list-style-type: none"> ▶ Operate the device within the specifications. <p>If the status indicator does not change, then send the device back to Bürkert.</p> |
| Incorrect Autotune or Autotune aborted. After a restart of the device, the error will be reset. | <ul style="list-style-type: none"> ▶ Make sure that the medium flows through the device. ▶ Check the Q_{nom} of the device. ▶ Start the Autotune again. <p>After a restart of the device, the error will be reset.</p> |

10.2 Status indicator is orange

| Cause | Solution |
|---|--|
| A calibration procedure is in progress. | <ul style="list-style-type: none"> ▶ Wait until the procedure is completed. |
| The Autotune is in progress. | <ul style="list-style-type: none"> ▶ Wait until the procedure is completed. |
| The operation mode of the device is set to Open-loop control mode , Manual set-point value or Analyze system . | <p>Refer to Select the source that gives the set-point value [▶ 31]</p> |

10.3 Status indicator is yellow



The yellow state is displayed up to 60 seconds after electrical power up. The device needs this time to reach the normal operation mode. After this initialisation the device will change to the green state.

| Cause | Solution |
|---|---|
| <p>One of the following values is out of specification. The sensor or the device can be damaged.</p> <ul style="list-style-type: none"> • the medium temperature • the device temperature • the supply voltage | <ul style="list-style-type: none"> ▶ Operate the device within the specifications. <p>If the status indicator does not change, then send the device back to Bürkert.</p> |
| <p>The set-point position for the actuator has (almost) reached 100%. The set-point value cannot be reached.</p> | <ul style="list-style-type: none"> ▶ Increase the inlet pressure or decrease the output pressure. ▶ If the pressure drop in the pipe is too high, then reduce the pressure drop. ▶ If the filters installed in the pipe are dirty, then clean the filters. |

10.4 Status indicator is blue

| Cause | Solution |
|--------------------------------------|---|
| <p>Error in the internal memory.</p> | <p>Maintenance is needed.</p> <ul style="list-style-type: none"> ▶ Contact the manufacturer. |

10.5 Status indicator is off

| Cause | Solution |
|-------------------------------------|--|
| <p>The device is not energised.</p> | <ul style="list-style-type: none"> ▶ Check the wiring. ▶ Make sure that the voltage supply is 24 V $\overline{=}$. ▶ Make sure that the power supply source is working properly. |

10.6 Status indicator goes out periodically

| Cause | Solution |
|---|--|
| <p>The power supply is intermittently dropping and the device restarts.</p> | <ul style="list-style-type: none"> ▶ Use a power supply with sufficient power output. |
| <p>The voltage drop in the connecting cable is too high.</p> | <ul style="list-style-type: none"> ▶ Increase the cross-section of the cable and reduce the cable length. |

10.7 Replacement device adopts none of the values from the defective device

| Cause | Solution |
|--|---|
| The article number of the replacement device is different from the article number of the defective device. | <ul style="list-style-type: none"> ▶ Use a replacement device that has the same article number than the defective device. <p>Values can only be transferred between devices with the same article numbers.</p> |
| The memory card is defective. The device could not write any values to the memory card. | <ul style="list-style-type: none"> ▶ Replace the memory card. <p>Refer to Replace the memory card [▶ 34].</p> |

10.8 Replacement device does not adopt all of the values from the defective device

| Cause | Solution |
|---|---|
| The device description of the replacement device is different from the device structure of the defective device. Only the existing values of the defective device can be adopted by the replacement device. | <ul style="list-style-type: none"> ▶ Use the Bürkert Communicator to configure the new values of the replacement device. |

10.9 No mass flow rate

| Cause | Solution |
|--|--|
| The pipes are too large or not yet fully vented. | <ul style="list-style-type: none"> ▶ Vent the pipe. ▶ Change the pipe diameter. |
| The flow-rate value is below the cut-off limit. | <ul style="list-style-type: none"> ▶ If the cut-off limit is too high, decrease the value of the cut-off limit. <p>Refer to Cut-off.</p> |
| The device is not in the normal operation mode, refer to Operation modes [▶ 29] . | <ul style="list-style-type: none"> ▶ If the device is not running one of the functions described in Select the source that gives the set-point value [▶ 31], then check the other possible causes of the problem. |
| The device is possibly running one of the functions described in Select the source that gives the set-point value [▶ 31] | |
| The set-point value is lower than the zero-point shut-off limit. | <ul style="list-style-type: none"> ▶ Increase the set-point value until it is higher than 2% of the nominal flow rate. |

10.10 Unstable measured value

| Cause | Solution |
|---|--|
| Functional earth (FE) is not connected properly. | <ul style="list-style-type: none"> ▶ To connect the functional earth, use a green-and-yellow cable that is as short as possible. <p>the cable cross-section must be at least equal to the cross section of the power-supply cable. Refer to Connect the functional earth [▶ 24]</p> |
| The residual ripple on the voltage supply is too high. | <ul style="list-style-type: none"> ▶ Use a supply voltage that conforms to the technical data given in Technical data [▶ 15] |
| The device must compensate for irregularities in an unstable pressure supply caused, for example, by pumps. | <ul style="list-style-type: none"> ▶ Install a suitable pressure regulator in front of the device. ▶ Install a buffer tank to absorb the pressure fluctuations. |
| The controller is unstable. | <ul style="list-style-type: none"> ▶ Run the Autotune function to adapt to the operating conditions. |

10.11 Set-point value at 0 %, but medium still flows

| Cause | Solution |
|---|--|
| The connected actuator is a proportional valve and the operating pressure is above the tight sealing pressure of the proportional valve. | <ul style="list-style-type: none"> ▶ Reduce the operating pressure. ▶ To eliminate the defect, return the device to the manufacturer. |
| The operating mode of the device is set to Open-loop control mode , and the actuator is open because the digital input triggers the opening of the actuator. | <ul style="list-style-type: none"> ▶ Set the device to the normal operating mode. <p>Refer to Normal operating mode (MFC) and to Select the source that gives the set-point value [▶ 31].</p> <ul style="list-style-type: none"> ▶ Check the operation of the digital input. <p>Refer to Digital input</p> |

10.12 Set-point value at 0 %, no mass flow, but a non-zero mass flow rate is measured

| Cause | Solution |
|---|---|
| The installation position of the device is incorrect. | <ul style="list-style-type: none"> ▶ Install the device as recommended in Medium connection [▶ 18] ▶ Run the Autotune function to adapt to the operating conditions. ▶ Run a zero point adjustment. <p>Refer to Zero point adjustment [▶ 28]</p> |

| Cause | Solution |
|---|--|
| The medium is different from the medium specified during the calibration. | <ul style="list-style-type: none">▶ Use the specified medium or send the device to the manufacturer for calibration with the new medium. |

10.13 Set-point value is not reached

| Cause | Solution |
|----------------------------------|---|
| The mesh filter is clogged. | <ul style="list-style-type: none">▶ Clean or replace the mesh filter.▶ Run the Autotune function to adapt to the operating conditions. |
| The outlet pressure is too high. | <ul style="list-style-type: none">▶ Make sure that the pipe diameters and the pipe lengths are adapted.▶ If the medium connection pipes after the device are dirty, then clean them. |
| The inlet pressure is too low. | <ul style="list-style-type: none">▶ Increase the inlet pressure to the calibration pressure value.▶ Make sure that the pipe diameters and the pipe lengths are adapted. |

11 Uninstallation

11.1 Dismantling

- ▶ Relieve the medium pressure in the installation.
- ▶ Flush the device with a neutral medium (for example nitrogen)
- ▶ Relieve the flushing medium pressure in the installation.
- ▶ De-energise the device.
- ▶ Remove the electrical wiring.
- ▶ Disconnect the medium connections.
- ▶ Remove the device.

12 Spare parts and accessories



Risk of injury and/or damage due to incorrect parts.

- ▶ Use only original accessories and original spare parts from Bürkert.



Order the parts directly on our [eShop](#).

12.1 Electrical accessories

- ▶ For further accessories, refer to the data sheet.

| | |
|--|------------|
| USB-büS-interface set, without power supply | 772551 |
| Memory card | on request |
| D-sub DE-9 female connector with 5 m cable, with stripped end | 580882 |
| D-sub DE-9 female connector with 10 m cable, with stripped end | 580883 |

12.2 Compression fittings for a device with G-internal-threaded connections

The threaded pipe-connection plates of the device obey standard DIN ISO 228/1. If the pipe fittings are not delivered with the device, then choose pipe fittings that are adapted to the medium connection of the device. Also order the seal depending on the medium connection and the pipe diameter.

| Device internal-threaded connection in accordance with DIN ISO 228/1 | Pipe diameter | Article number | |
|--|---------------|-------------------------------------|-----------------------|
| | | Stainless steel compression-fitting | Seal (1 piece) |
| G 1/4 | 6 mm | 901538 | 901575 (Copper) |
| G 1/4 | 8 mm | 901540 | |
| G 1/4 | 1/4" | 901551 | 901579 (Rubber steel) |
| G 1/4 | 3/8" | 901553 | |

Tab. 9: Stainless steel compression fittings and related seals

12.3 Additional software

Bürkert Communicator

Download from country.burkert.com

Tab. 10: Documentation and software

13 Logistics

13.1 Transport and storage

- ▶ Protect the device against moisture and dirt in the original packaging during transportation and storage.
- ▶ Avoid UV radiation and direct sunlight.
- ▶ Protect connections, if present, from damage with protective caps.
- ▶ Observe the permitted storage temperature.
- ▶ Remove cables, connectors, external filters and installation equipment.
- ▶ Clean and vent contaminated devices.

13.2 Return



No work or tests will be carried out on the device until a valid Contamination Declaration has been received.

- ▶ To return a used device to Bürkert, contact the Bürkert sales office. A return number is required.

13.3 Disposal

Environmentally friendly disposal



- ▶ Follow national regulations regarding disposal and the environment.
- ▶ Collect electrical and electronic devices separately and dispose of them as special waste.

Further information at country.burkert.com