

Type büS

BÜRKERT SYSTEM BUS

Cabling guide büS/EDIP



Supplement to Operating Instructions

We reserve the right to make technical changes without notice.

© Bürkert Werke GmbH & Co. KG 2020-2026

Technical documentation 2602/04_GBen_00815392_280737419_36028798251649163 / Original EN









Contents

1	Symbols used	6
2	Introduction	7
2.1	Preface	7
2.2	What is the Bürkert system bus (büS/EDIP)?	7
2.3	For whom is this Design Guideline intended?	7
2.4	What is the purpose of the Design Guideline?	7
2.5	Bürkert quality standard	7
3	Creating a rough project plan	8
3.1	Block diagram, devices, position, protocols	8
4	Getting to know the basics of a büS infrastructure – accessories, cables, pin assignment	9
4.1	What is the purpose of the various accessories	9
4.2	Accessories	9
4.2.1	Y-connector	9
4.2.2	Passive junction box	10
4.2.3	Gender changer	10
4.2.4	Termination	11
4.3	Cable configuration	11
4.3.1	Characteristic impedance and cables standards	11
4.3.2	Connecting cables	11
4.3.3	Extension cables	11
4.4	Pin assignment	12
4.4.1	M12 connector male, 5-pin (A-coded)	12
4.4.2	M12 connector male, 8-pin (A-coded)	12
4.4.3	Terminal block, 5-pin	12
4.4.4	Terminal block, 4-pin	13
5	Getting to know the büS topologies	14
5.1	What is a bus topology and why do you need it?	14
5.2	Common terms of bus topology	14
5.2.1	Trunk line	14
5.2.2	Stub line	14
5.2.3	Overview of cable lengths	14
5.2.4	Example	15
5.3	Which topologies are recommended?	15
5.3.1	Line topology (daisy chain)	15
5.3.2	Line topology with stub lines	16
5.3.3	Star topology	16
5.4	Which topologies are NOT recommended?	17
5.4.1	Tree topology	17
5.5	Which topologies are NOT permitted	18
5.5.1	Ring topology	18
6	Detailed project plan 1	19
6.1	Floor plan	19
6.1.1	Network with a junction box	19
6.1.2	Network with Y-connectors	20
6.1.3	Mixed network	20

7	Technical know-how	21
7.1	Termination resistors	21
7.2	Connection for diagnostics	21
8	Detailed project plan 2	22
8.1	Completion – floor plan	22
8.1.1	Network with a junction box	22
8.1.2	Network with Y-connectors	22
8.1.3	Mixed network	23
9	Network power supply	24
9.1	Power segments	24
9.1.1	One power segment	24
9.1.2	Additional power supply	24
9.2	Rule of thumb	25
10	Detailed project plan 3	26
10.1	Cabling plan	26
10.1.1	Network with junction box	26
10.1.2	Network with Y-connectors	26
10.1.3	Mixed network	27
11	bÜS network shielding	28
11.1	Shielding of EDIP devices	28
11.2	Comparison of shieldings	29
11.3	Network with direct shielded devices	30
11.4	Network with RC shielded devices	31
11.5	Network with none shield connected devices	32
11.6	Mixed network with various shieldings	33
12	Best practice instructions	35
12.1	Termination resistor	35
12.2	Signal reflections	35
12.3	Passive junction box	35
12.4	Diagnostic port	35
12.5	Baud rate	35
12.6	bÜS stick	35
12.7	Stub lines	36
12.8	Bus load	36
12.9	Power consumption	36
12.10	Grounding power supplies	36
12.11	Shielding of bÜS network	36
13	bÜS networks with maximum network expansion	37
13.1	Line topology	37
13.1.1	500 kbit/s	37
13.1.2	250 kbit/s	38
13.1.3	125 kbit/s	39
13.2	Star topology with a junction box	40
13.3	Tree topology with a junction box	41
14	Troubleshooting	42
14.1	Sporadic disconnections	42

14.2	Red LED (failure)	42
14.3	Orange LED on the device (functional check)	43
14.4	Yellow LED on the device (out of specification)	43
14.5	Blue LED on the device (maintenance required)	44
14.6	Restarting some devices	44
15	Accessories	45
15.1	büS accessories	45
15.2	Software	45
15.3	Network accessories	46
15.4	Cable accessories	46
15.4.1	büS cable	46
15.4.2	büS push-in connector for field wiring	48
15.4.3	Sensor/actuator cable	48
15.4.4	Sensor/actuator push-in connector for field wiring	50
15.4.5	Power cable	51
15.4.6	Industrial Ethernet cable	53
15.4.7	Ethernet push-in connector for field wiring	55

1 Symbols used

-  Trunk line
-  Stub line
-  Y-connector
-  Y-connector with interrupt
-  Termination resistor
-  Power supply
-  Measurement point
-  Diagnostics

2 Introduction

2.1 Preface

The aim of this Design Guideline is to provide you with practical information on how to plan your automation plant using Bürkert devices based on the Bürkert system bus (büS). The various aspects involved in the planning, assembly and operation processes are all considered. The structure of the Design Guideline helps you build knowledge and apply it through different steps based on examples.

2.2 What is the Bürkert system bus (büS/EDIP)?

The Bürkert system bus, also referred to as büS, is based on the widely spread CANopen standard and is fully downwards compatible to this standard. The büS concept does not require a master. Field devices can easily interchange process data and detailed diagnostic data. A gateway allows access to this information from a higher-level system. The Bürkert digital device platform EDIP (Efficient Device Integration Platform) opens the door to endless possibilities for a digital future.

2.3 For whom is this Design Guideline intended?

The Design Guideline is intended for engineers or plant builders who are familiar with the planning and engineering of automation plants containing fieldbuses, especially CAN-based protocols like CANopen and DeviceNet. The Design Guideline summarises the additional knowledge required to plan büS/EDIP networks. The most important steps for planning, creating and commissioning büS devices are outlined herein.

2.4 What is the purpose of the Design Guideline?

The Design Guideline aids the planning of a büS/EDIP system. In a comprehensive approach based on illustrative and practical examples, the Design Guideline walks you through the Do's & Don'ts to ensure a fully functional system.

This Design Guideline explains in detailed individual steps how to plan a büS network.

2.5 Bürkert quality standard

All devices with a büS/EDIP interface have to obtain an internal certification which consists of a software and hardware measurement. Therefore, we can ensure that all Bürkert devices have attained the same quality standard. Currently, there are two approved CAN transceivers that meet these requirements.

3 Creating a rough project plan

3.1 Block diagram, devices, position, protocols

Which devices are planned?

Create an overview of the positioning of your devices.

Are the devices distributed in an equidistant or a non-equidistant manner?

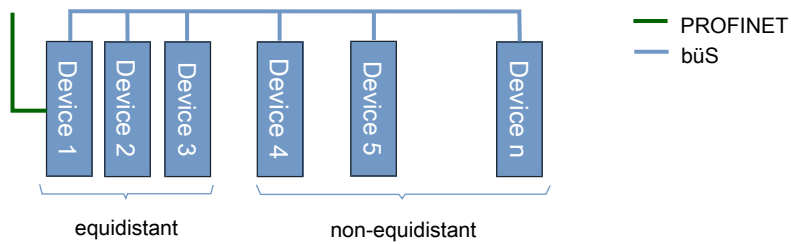

Fig. 1: Project plan

4 Getting to know the basics of a büS infrastructure – accessories, cables, pin assignment

4.1 What is the purpose of the various accessories

In this chapter, the various components required for cabling are explained in detail.

büS devices are widely equipped with standard M12 connectors and. different accessories are available for a range of cabling tasks.

4.2 Accessories

4.2.1 Y-connector

Definition: A Y-connector has three M12 connectors in total. On one side of the connector, there is one male and one female connector. On the other side, there is one female connector.

Purpose: Since most büS devices have a single M12 büS connector, the Y-connector enables another connection option to the next device. The single connector side is connected to the device and the other two connectors may be used for the devices to the left and the right.

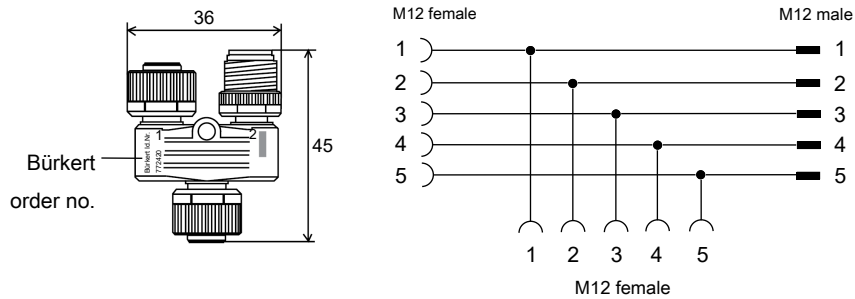

Fig. 2: Y-connector

A Y-connector with interrupt is also available. This connector is used for segmenting power. The pin 2 connection is interrupted. It is therefore possible to use a new power supply for the next büS segment if the limit of 100 W has been reached.

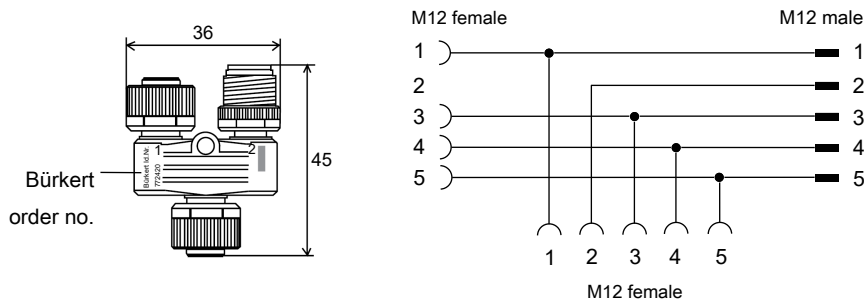

Fig. 3: Y-Connector with interrupt

Type bÜS

Getting to know the basics of a bÜS infrastructure – accessories, cables, pin assignment

4.2.2 Passive junction box

Definition: A passive junction box is an IP65/IP67 block with connectors for the power supply and multiple bÜS connectors. It is a passive module and, therefore, does not have to be configured.

Purpose: The passive junction box allows multiple connections to bÜS devices in a star form. The Y-connectors on each device become redundant when using a passive junction box, thus making cabling in the field much simpler.

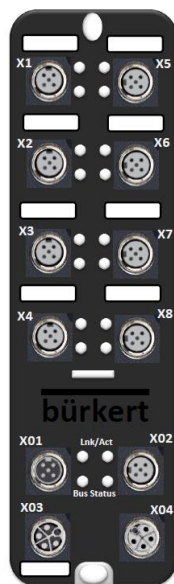

Fig. 4: Passive junction box

4.2.3 Gender changer

Definition: A gender changer is an IP65/67 component with two male M12 connectors.

Purpose: It is used to connect two female M12 connectors.

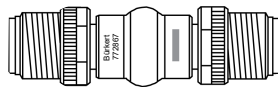

Fig. 5: Gender changer

Type bÜS

Getting to know the basics of a bÜS infrastructure – accessories, cables, pin assignment

4.2.4 Termination

Definition: A termination resistor is available as an M12 connector (female and male) or as a chip and has to be used twice in one network.

Purpose: To avoid signal reflections in the cable, the bÜS network always needs to be terminated with two 120 Ω resistors at the ends of the cable. One is required at the beginning of the network and one at the end.

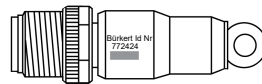

Fig. 6: Termination

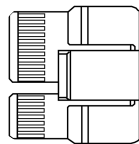

Fig. 7: Termination resistor chip

4.3 Cable configuration

There are two types of cable: connecting cables and extension cables. All cables are available with different cable lengths. An overview can be found in the appendix.

4.3.1 Characteristic impedance and cables standards

All nodes are connected to each other through a physically conventional two-wire bus. The wires are a twisted pair with a 120 Ω (nominal) characteristic impedance. CiA 301 (CANopen application layer) is standardised as EN 50325-4.

4.3.2 Connecting cables

Definition: Connecting cables are equipped with a female M12 connector on one side and with open leads on the other.

Purpose: These cables connect a device with a terminal block to an M12 connector, e.g. gateway Type ME43.

4.3.3 Extension cables

Definition: Extension cables are equipped with a female M12 connector on one side and with a male M12 connector on the other.

Purpose: These cables are used to connect a device with an M12 connector.

Type büS

Getting to know the basics of a büS infrastructure – accessories, cables, pin assignment

4.4 Pin assignment

Various standard connectors are available for Bürkert devices with a büS interface.

4.4.1 M12 connector male, 5-pin (A-coded)

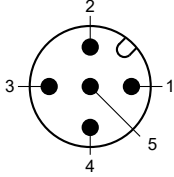
M12 connector male, 5-pin (A-coded)	Pin	Assignment
	1	SHIELD
	2	V+
	3	DGND
	4	CAN_H
	5	CAN_L

Tab. 1: M12 connector male, 5-pin (A-coded)

4.4.2 M12 connector male, 8-pin (A-coded)

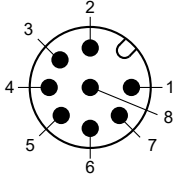
M12 connector male, 8-pin (A-coded)	Pin	Assignment
	1	V+
	2	DGND
	3	CAN_L
	4	CAN_H
	5	Device specific
	6	Device specific
	7	Device specific
	8	Device specific

Tab. 2: M12 connector male, 8-pin (A-coded)

4.4.3 Terminal block, 5-pin

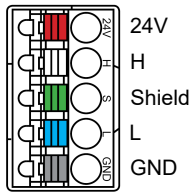
Terminal block, 5-pin	Pin (colour)	Assignment
	Red	24 V DC
	White	CAN_H (büS-connection)
	Green	SHIELD
	Blue	CAN_L (büS-connection)
	Black	GND

Tab. 3: Terminal block, 5-pin

Type büS

Getting to know the basics of a büS infrastructure – accessories, cables, pin assignment

4.4.4 Terminal block, 4-pin

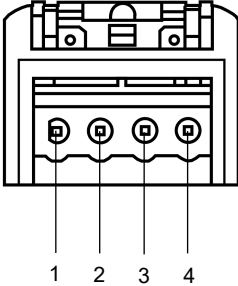
Terminal block, 4-pin	Pin	Assignment
	1	DGND
	2	CAN_L
	3	CAN_H
	4	+24 V DC

Tab. 4: Terminal block, 4-pin

5 Getting to know the büS topologies

5.1 What is a bus topology and why do you need it?

The arrangement of different devices on the bus defines the topology. Different topologies influence the quality of communication and certain topologies are, therefore, recommended to achieve a good network design.

5.2 Common terms of bus topology

5.2.1 Trunk line

A trunk line is the main part of a CANopen cabling solution. All devices and junction boxes are connected to it.

5.2.2 Stub line

A stub line is a branch of the trunk line and allows connection to a device that is not located close to the trunk line. The use of stub lines must be avoided as much as possible. However, there are several limitations depending on the baud rate of the network.

5.2.3 Overview of cable lengths

Overview of maximum cable lengths in the CANopen specification:

Baud rate	max. trunk length	max. stub line length	max. length all stubs
50 kbit/s	1000 m	50 m	250 m
125 kbit/s	500 m	20 m	100 m
250 kbit/s	250 m	10 m	50 m
500 kbit/s	100 m	5 m	25 m
1 Mbit/s	20 m	1 m	5 m

Tab. 5: Cable lengths

This table shows an overview of theoretical values for an ideal network. Nevertheless, there are more dependencies regarding the trunk line length, the stub line length, the amount of process data and the baud rate.

5.2.4 Example

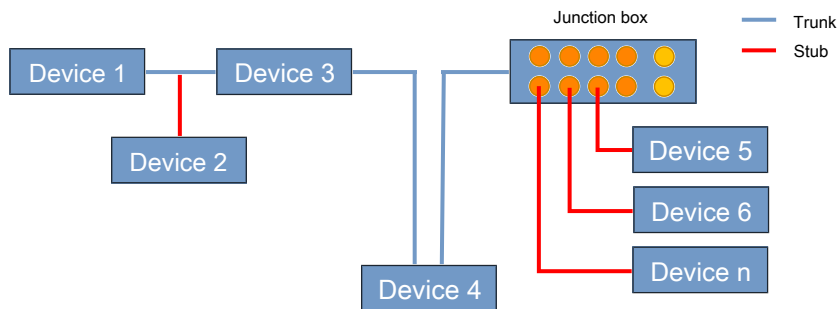

Fig. 8: Example

5.3 Which topologies are recommended?

The following topologies achieve the best results with regard to signal quality.

5.3.1 Line topology (daisy chain)

All devices are connected in single row without a stub line.



Fig. 9: Line topology

5.3.2 Line topology with stub lines

The trunk line of the network is connected directly to the next device. If this is not possible, use a stub line. Avoid stub lines as much as possible and keep them short. Please note the maximum stub line length that depends on the baud rate.

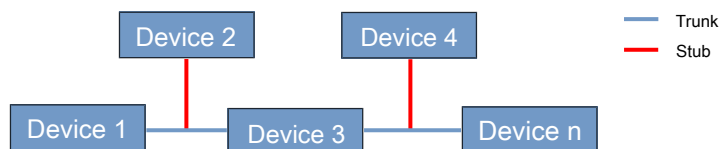

Fig. 10: Line topology with stub lines

5.3.3 Star topology

A star topology is used to interconnect devices when space is limited and a setup with a daisy chain topology is not possible.

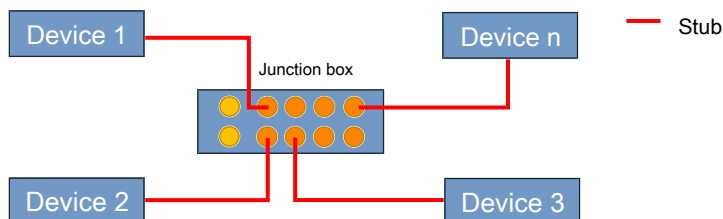

Fig. 11: Star topology

5.4 Which topologies are NOT recommended?

The topologies in this chapter are possible, but various criteria have to be observed to ensure the network works properly.

5.4.1 Tree topology

For signal quality, it is not recommended to use a tree topology. Cascading of the passive junction boxes is restricted to three. If more devices are needed, it is necessary to interconnect the trunk lines of the passive junction boxes and to not cascade more than three devices. Otherwise, the maximum stub line length is exceeded and errors may occur.

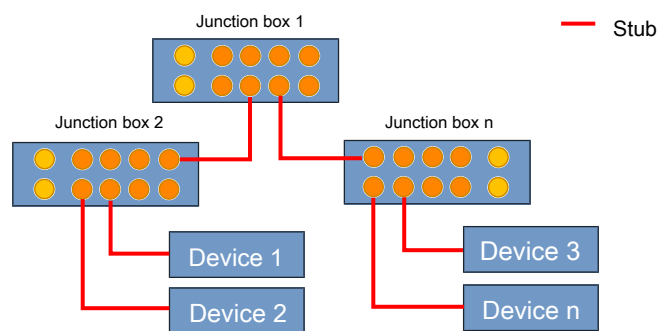

Fig. 12: Tree topology

5.5 Which topologies are NOT permitted

The topologies described in this section are not permitted. Never use them in a büS or CANopen network.

5.5.1 Ring topology

A ring topology is not permitted in a CANopen network. Choose another topology for the network.

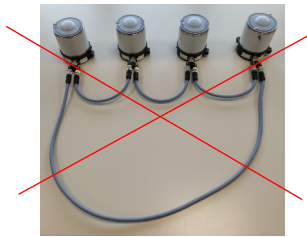
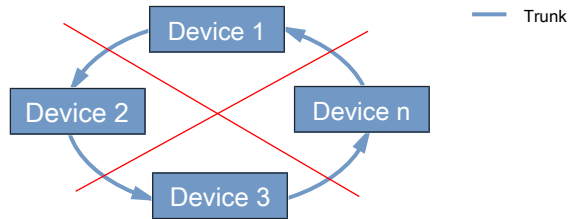

Fig. 13: Ring topology

6 Detailed project plan 1

6.1 Floor plan

Create a detailed project plan using the aforesaid information about devices, cables lengths, topology, junction boxes and Y-connectors.

Are the devices close to each other?

YES: plan the network with a passive junction box

NO: plan the network with Y-connectors

Rules:

- Connect all the accessories on the trunk line
- Connect the accessories directly to the device
 - Use stub lines to connect the devices
 - Avoid long stub line lengths

6.1.1 Network with a junction box

In a network with one passive junction box, all the cables will be viewed as stub lines since there is no trunk line. Keep the stub lines as short as possible.

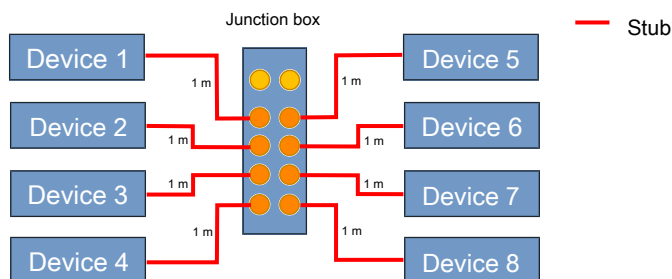

Fig. 14: Network with a junction box

6.1.2 Network with Y-connectors

A network with Y-connectors without stub lines (directly connected to the M12 connector of the device)

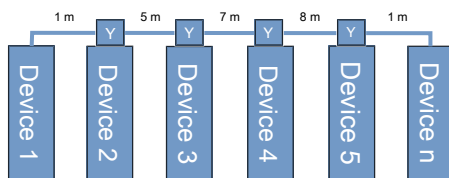

Fig. 15: Network with Y-connectors without stub lines

Network with Y-connectors and stub lines

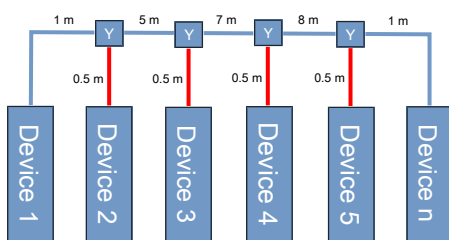

Fig. 16: Network with Y-connectors and stub lines

6.1.3 Mixed network

In a mixed network, it is important to indicate the total length of the cables. This includes the length of all trunk lines and stub lines.

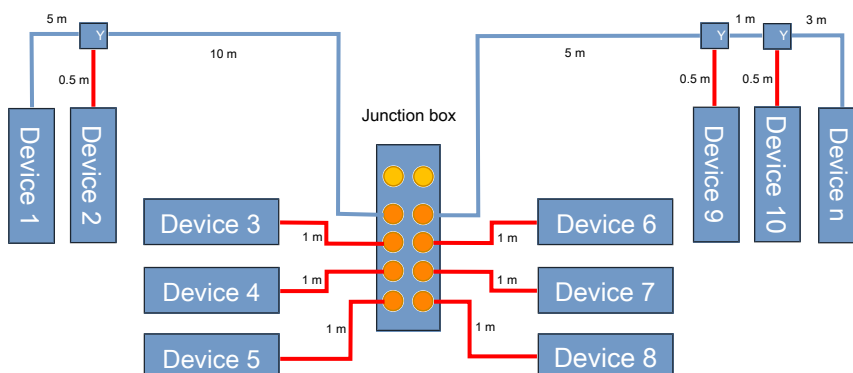

Fig. 17: Mixed network

7 Technical know-how

7.1 Termination resistors

Termination resistors are located on each side of the trunk line. The impedance is approximately 60Ω between CAN-HIGH and CAN-LOW.

Exception: In a large network with long stub lines, the longest distance between two devices should be estimated. It is also recommended to choose the longest distance in a network that consists of more than one passive junction box.

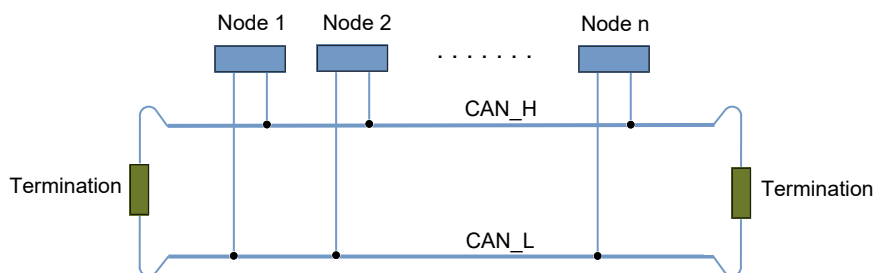

Fig. 18: Termination resistors

7.2 Connection for diagnostics

We recommend providing a free connection for diagnostics. A port of the junction box or an extra Y-connector in the network can be used. This access is important for fast diagnostics with būs stick and the Bürkert Communicator software.

Furthermore, it can be used for measurements with external tools, e.g. GEMAC CANBUS Tester 2. In this case, a measurement connection at both ends is recommended.

8 Detailed project plan 2

8.1 Completion – floor plan

A cabling plan using the accessories, cables lengths, topology, junction box, Y-connector, termination resistor and a diagnostics port must be created.

8.1.1 Network with a junction box

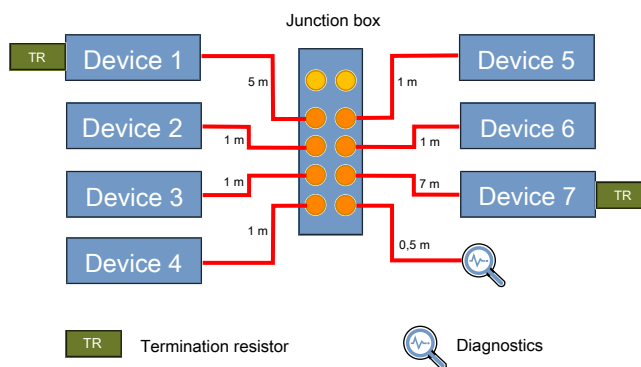

Fig. 19: Network with a junction box

In a network with a passive junction box, the termination resistors are connected to the devices with the longest distance to each other.

8.1.2 Network with Y-connectors

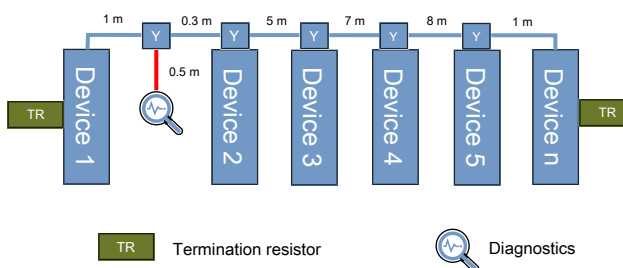

Fig. 20: Network with Y-connectors

Network without stub lines. The Y-connector is connected directly to the device.

8.1.3 Mixed network

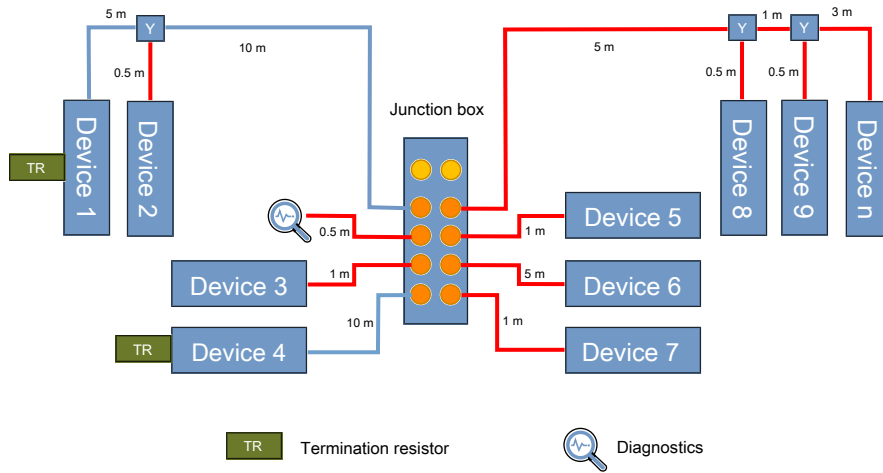

Fig. 21: Mixed network

For good signal quality, it is important to determine the longest distance between two devices in the entire network. Place the termination resistors close to these devices. This helps to reduce the signal reflections. Please do not exceed the maximum stub line length.

9 Network power supply

9.1 Power segments

Calculate the overall power consumption of all the devices in the network. Build power segments with a maximum load of 100 W. This refers to the M12 connector (A-coded). This component has a current limit of approx. 4 A.

9.1.1 One power segment

In a network with one power supply, overall power consumption is limited to 100 W.

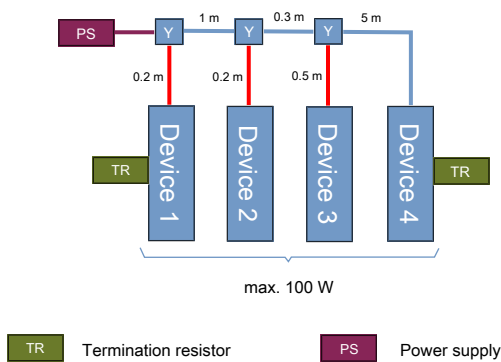

Fig. 22: One power segment

9.1.2 Additional power supply

For higher power consumption, use additional power supplies and Y-connectors with interrupt to utilise power from a second power supply.

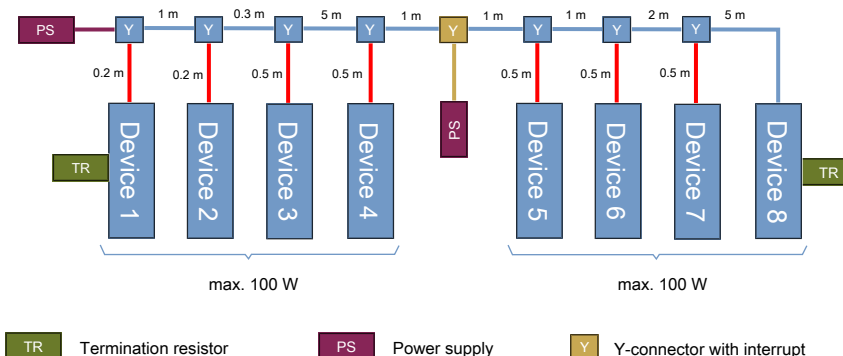

Fig. 23: Additional power supply

9.2 Rule of thumb

The rule of thumb is that 1 W load per metre results in a voltage drop of 1 mV. A maximum voltage drop of 5 V is allowed. Some devices will shut down if the supply voltage is lower than 19 V. Therefore, refer to the respective data sheet for more information.

10 Detailed project plan 3

10.1 Cabling plan

Rough cabling plan, topology, rules of cabling (table).

Place your power supply (power < 100W) close to the load.

Y-connector, passive junction box, external power supply, galvanically isolated switched-mode power supplies (recognised UL Class 2).

10.1.1 Network with junction box

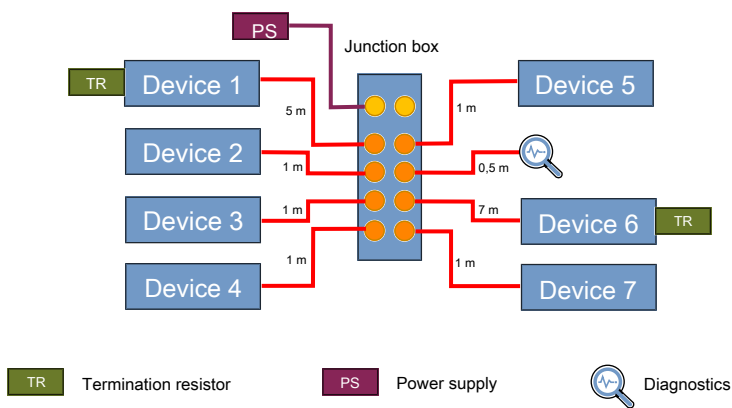

Fig. 24: Network with junction box

10.1.2 Network with Y-connectors

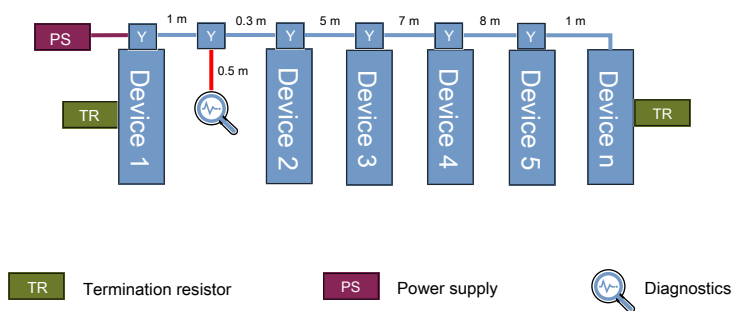

Fig. 25: Network with Y-connectors

10.1.3 Mixed network

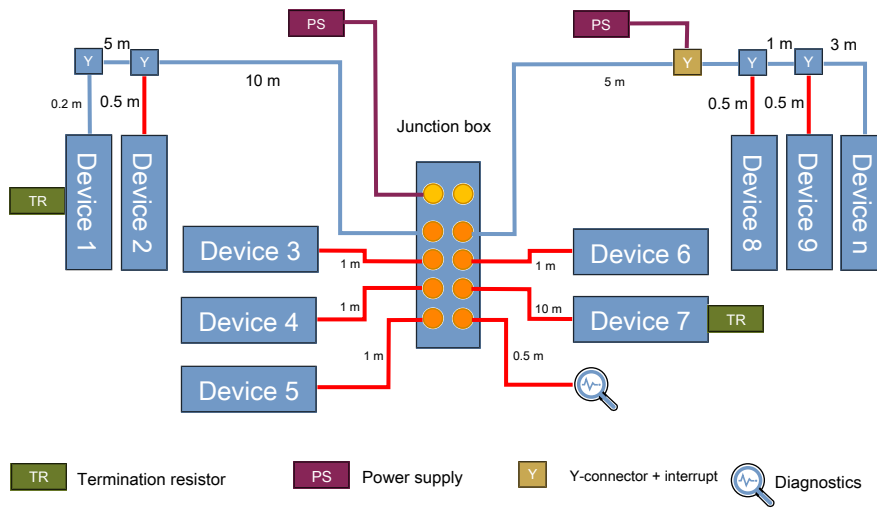

Fig. 26: Mixed network

11 büS network shielding

11.1 Shielding of EDIP devices

Detailed shielding information for each device can be found in pin assignment of technical data sheet and operating instructions. There are three types of device-internal shieldings:

Direct: Direct connection of shield to FE

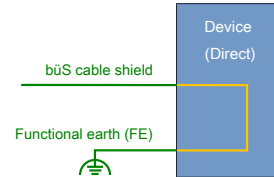

RC: Parallel connection of resistor and capacitor to FE

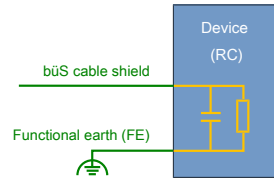

None: No shield connection

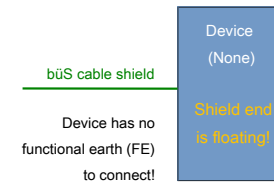

Tab. 6: büS network shielding

11.2 Comparison of shieldings

Shielding	Reasons for/when using	Restrictions for installation or disadvantages
DIRECT Connection of shield to FE	<ul style="list-style-type: none"> • Best shielding effect • Metal housing (e.g. stainless steel for "clean design") 	Equipotential FE grounding system in plant is mandatory.
RC Parallel connection of resistor and capacitor to FE	<ul style="list-style-type: none"> • Second best shielding effect • Also practicable when FE quality is poor • Recommended shielding for safety applications to prevent compensation currents 	Shielding effect may not be sufficient in very rough H-field emitting environments.
NONE	No FE on device available (e.g. due to customer requirement)	To have any shielding effect, cable shield must always led near by device with no significant stiches (stubs). The shielding is carried out on subsequent or adjacent devices.

Tab. 7: Comparison

11.3 Network with direct shielded devices

Shield is grounded at multiple points to FE. Direct shield connection on both cable ends or at multiple devices to FE has shielding effects against E and H fields. But take care for equipotential FE grounding area to prevent compensation currents over shield!

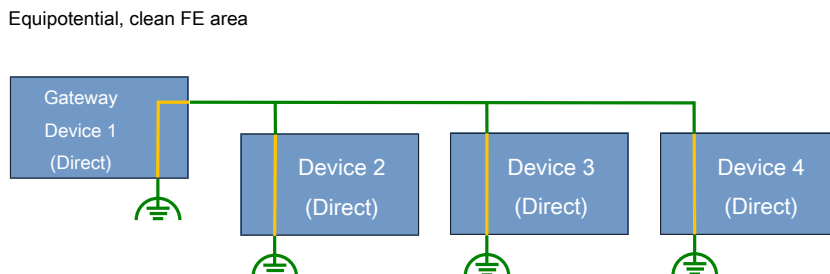

Fig. 27: Direct shielded device

If equipotential FE area is not feasible, e.g. between two buildings, there are some measures to improve; e.g. add bypass conductor or a grounded cable duct nearby bÜS cable.

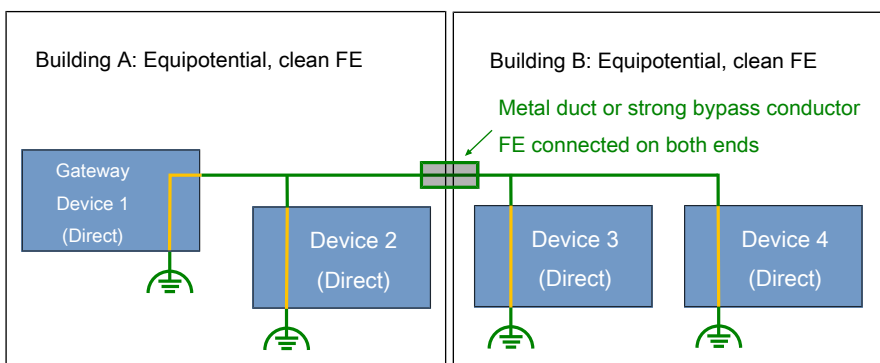

Fig. 28: Direct shielded device, 2 buildings

Explanation of graphic elements:

- Each device-internal shielding (None, Direct, RC) is said in brackets.
- Green line represents bÜS cable shield.

11.4 Network with RC shielded devices

In a network with RC shielded devices, shield must be only on one point directly connected to FE. This shielding set-up only shields E-Fields, but it is usually preferred, when FE area connection is poor.

- Either by using one direct shielded device.

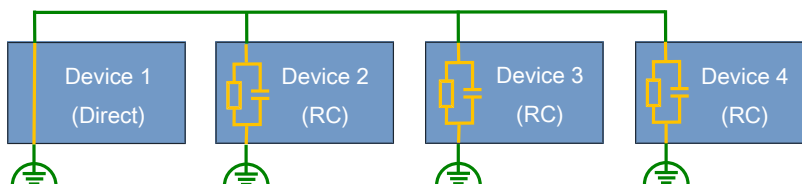

Fig. 29: RC shielded

- Or by grounding the cable shield directly anywhere in network, e.g. in the middle or near a source of EMC disturbance for immediate derivation.

In general, a distance between H-Field emitting machines and bÜS network is recommended. If not possible, use grounded metal duct for additional shielding the bÜS cable in whole.

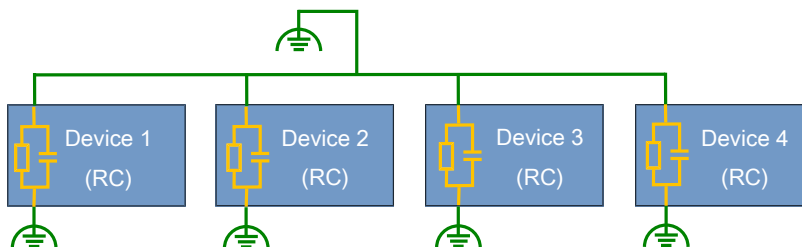

Fig. 30: RC shielded

11.5 Network with none shield connected devices

Not recommended to have "None" shield connected devices only. Network shield would be floating at all and this is equal to unshielded.

When using devices without an internally connected shield, take care that one end of bÜS shield must be connected directly to FE. Either a direct or RC shield connection can be used at the other shield end. The devices of the shielding type "None" are located in between with minimal stitches (e.g. with T-piece).

- For this, use either devices at the ends of network.

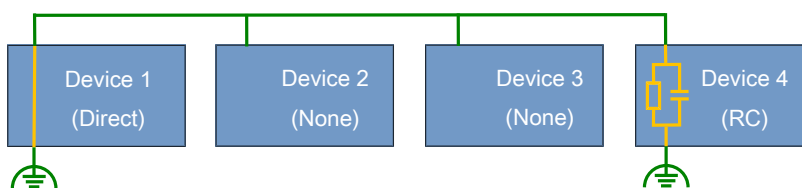

Fig. 31: bÜS network with devices without internal shield connection (shielding "None")

- Or connect cable shield directly to FE on both ends (example).

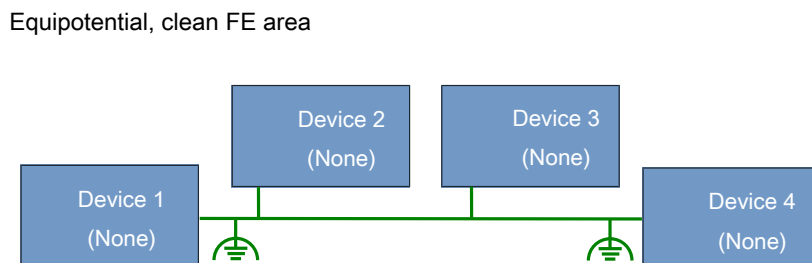

Fig. 32: bÜS network with devices without internal shield connection (shielding "None")

11.6 Mixed network with various shieldings

A planned büS network (a) is revised, some issues were identified (b) and finally some solutions are found (c).

a) Initial network

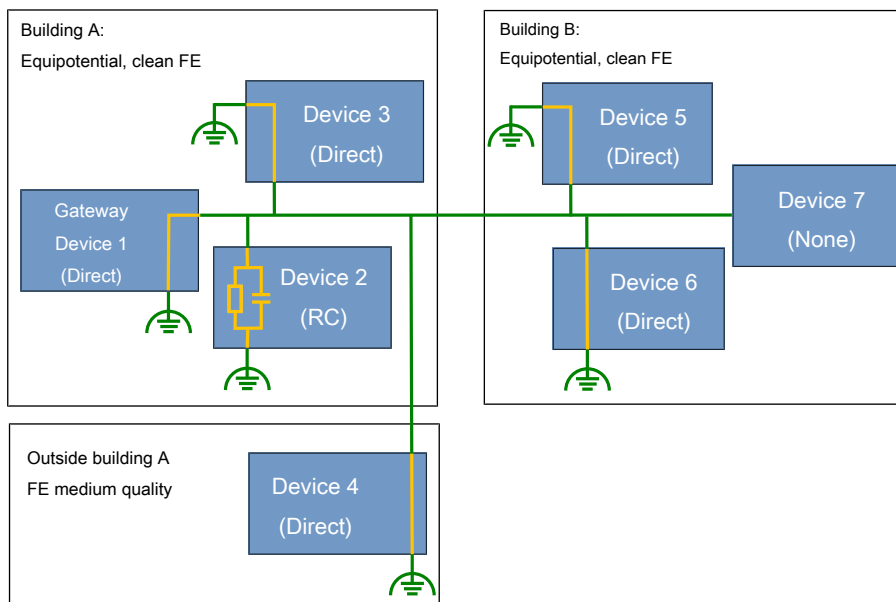
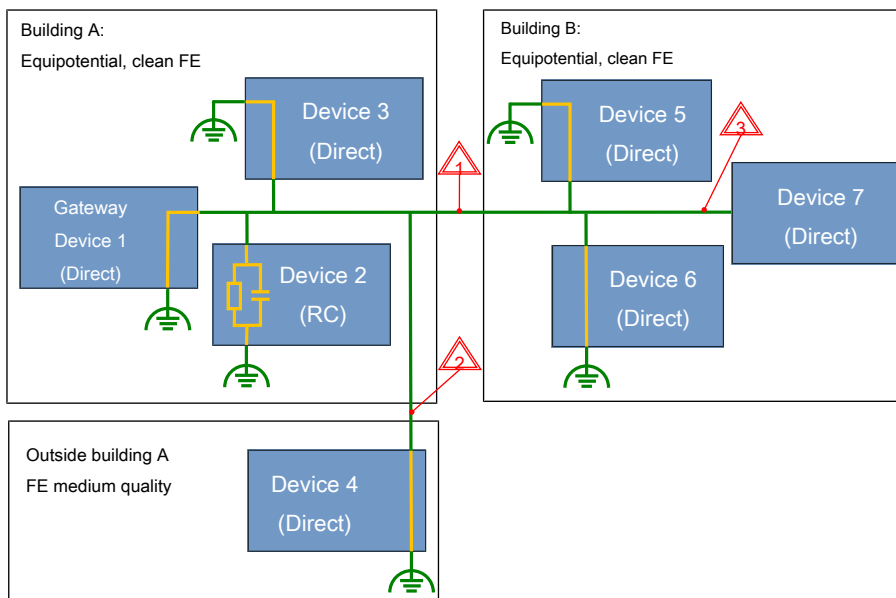

Fig. 33: Initial network

b) Problem identification



Identified issues:

- 1 FE with potential differences between building A and B
- 2 FE with potential differences between building A and outside
- 3 Long büS line with open shield to device 7 with no shield connection.

Fig. 34: Problem identification

c) Modifications (possible solutions)

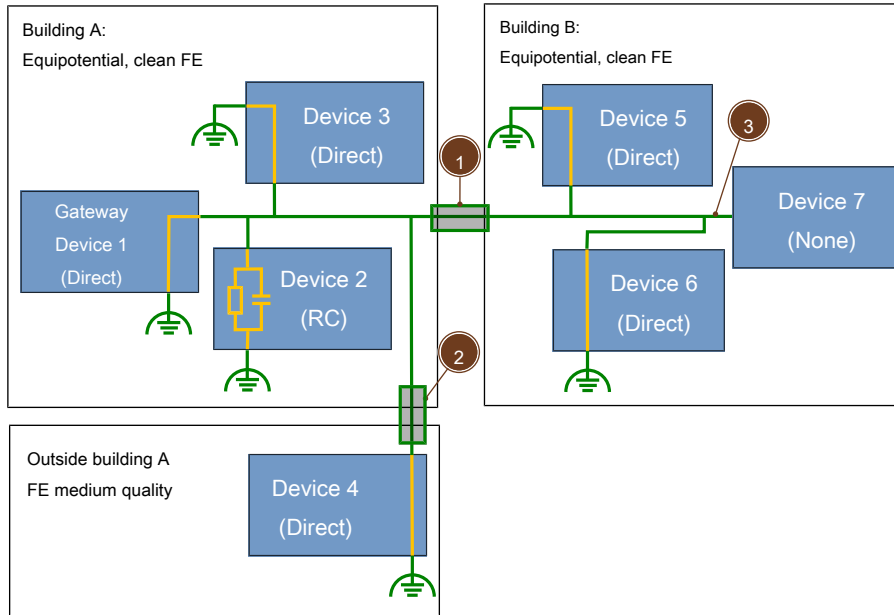

Applied solutions:

- 1 Add both-end FE grounded and low-impedance metal duct or bypass conductor between building A and B
- 2 Add both-end FE grounded and low-impedance metal duct or bypass conductor, led as near as possible to device 4.
- 3 Reduce unshielded cable length, by changing trunk line: Shield is led directly past device 7 (e.g. with T-piece) and grounded at device 6 afterwards.

Fig. 35: Examples of possible modifications

12 Best practice instructions

12.1 Termination resistor

Termination resistors are located on each side of the trunk line. Each resistor has a resistance of approx. 120 Ω . Therefore, a network with a termination resistor at both ends has an impedance of 60 Ω . Resistors are available as a male or female M12 connector. Additionally, a chip resistor for ME43 and valve island Type 8652 is available.

12.2 Signal reflections

There might be more than one reason for signal reflections in a network. This depends on the number of devices, the baud rate, the amount of process data, the position of the termination resistors and the position of the measurement port.

Massive signal reflections occur if the position of the termination resistors is not selected correctly.

12.3 Passive junction box

Passive junction boxes are used for the distribution of devices that are close to each other. In a network with a passive junction box, it is important to determine the longest distance between two devices and to place the termination resistor there. In this case, it is not recommended to place these resistors on the trunk line.

12.4 Diagnostic port

In a bÜS network, one diagnostic port should be placed in one plant. It is used for fast access with the Bürkert Communicator or also a third-party tool, e.g. GEMAC CAN Bus Tester 2.

12.5 Baud rate

The default baud rate of all Bürkert devices is 500 kbit/s. In the case of a poor measurement result, it is possible to reduce the baud rate to 250 kbit/s or 125 kbit/s. Therefore, longer cables can be used in the network.

Please note that the total time of a firmware update increases when the baud rate is reduced to a lower communication speed.

12.6 bÜS stick

The bÜS stick is a USB-to-CAN converter and is connected to a laptop/PC with the Bürkert Communicator. It is used for the diagnostics, start-up and parameterisation of devices.

12.7 Stub lines

The total length of stub lines in the entire network should be reduced as much as possible. It is impossible to calculate exactly the impact that a one metre stub line has on reducing the signal quality in percentage terms.

12.8 Bus load

The maximum bus load is 40%. The specific bus load of a device is specified in the communication data sheet. To calculate the total bus load, sum up the values from the communication data sheet for all devices.

12.9 Power consumption

It is important to consider the power consumption of a device as early as possible in the planning. Using the information about the total power consumption of the network, the accessories and the number of power supplies can be planned.

Furthermore, the permitted voltage ripple of a device must be considered. For devices with direct access, e.g. MFCs, it is important to have a low residual ripple. For sensors, the impact is not that significant.

12.10 Grounding power supplies

Power supplies should not be earthed, but it is important to ensure galvanic isolation. Otherwise, huge loops may develop that can have a negative impact on the entire network.

12.11 Shielding of büS network

Provide good, continuous functional earth (FE) with low impedance and noise. If this cannot be ensured in the area of the büS network, use a low-impedance metallic cable duct or bypass conductor grounded on both sides to prevent compensation currents over büS shield.

Connect devices of the internal shielding "None" directly to the büS strand (without stitch). The shielding must be on upstream or downstream devices in the network, but at least on end devices.

Connect at least one point of büS shield directly to FE (e.g. by using a device with direct FE connection to shield).

Keep a distance from H-Field emitting machines with high power consumption. If not possible, use metal duct grounded on both sides or multiple times for additional shielding of the büS cable .

13 büS networks with maximum network expansion

Networks with varying devices, cable lengths, baud rates and topologies are tested.

The networks shown here should only serve as examples of what is possible and are intended as a reference point for your own setup. For large networks close to the limit or even above, it always makes sense to check the network quality.

13.1 Line topology

For the baud rates 500 kbit/s, 250 kbit/s and 125 kbit/s the maximum cable length and the maximum number of devices have been determined.

13.1.1 500 kbit/s

Communication of the entire büS network worked with up to 84 devices and 1 büS stick. The total cable length was 75 metres.

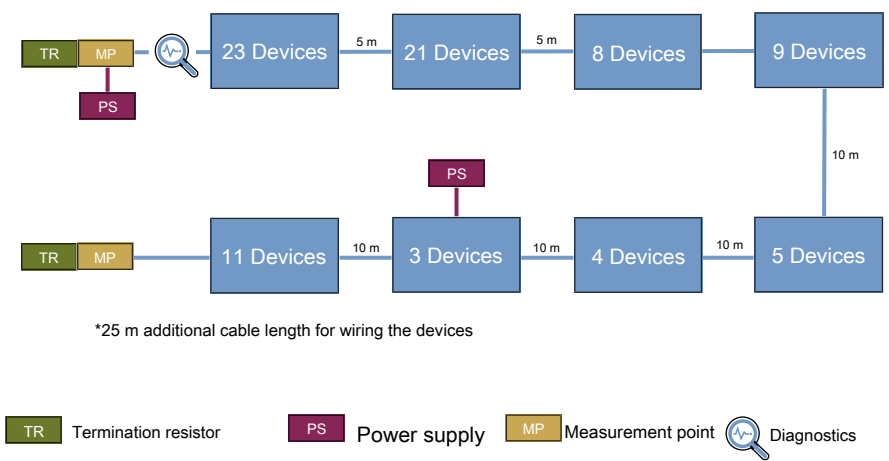

Fig. 36: 500 kbit/s, 84 devices, cable length 75 m

Measurements with a maximum cable length of 100 metres was possible with 44 devices and 1 büS stick. A length of 100 metres is defined as the limit in the CANopen specification.

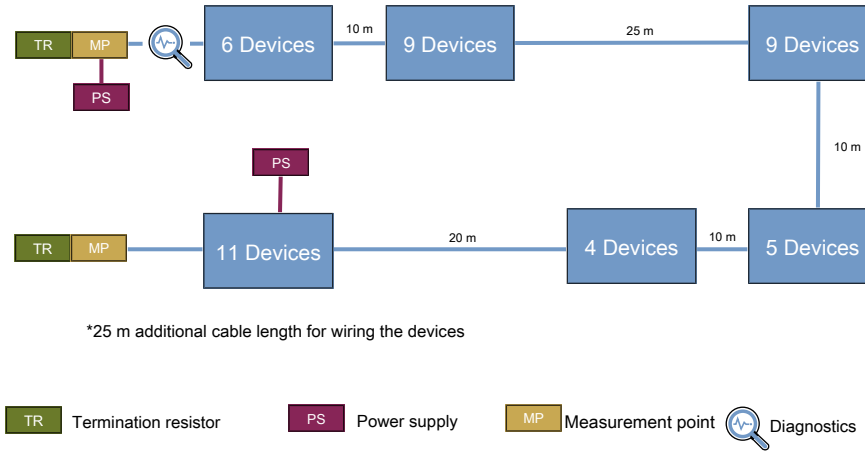

Fig. 37: 500 kbit/s, 44 devices, cable length 100 m

13.1.2 250 kbit/s

The network was tested with 84 devices and a total cable length of 175 metres and worked without any errors.

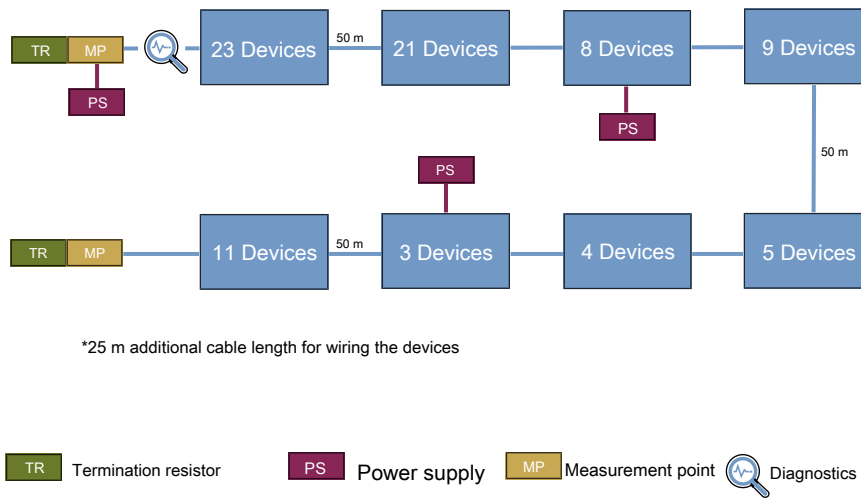

Fig. 38: 250 kbit/s, 84 devices, cable length 175 m

The system setup consists of 41 büS devices and 1 büS stick with a total cable length of 250 metres, which is defined as the maximum.

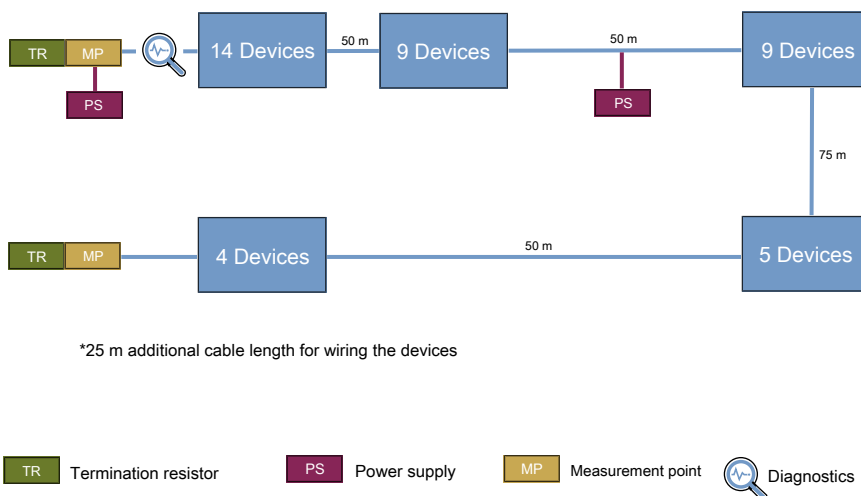

Fig. 39: 250 kbit/s, 41 devices, cable length 250 m

13.1.3 125 kbit/s

The network can have a total cable length of 475 metres with 84 devices and 1 büS stick.

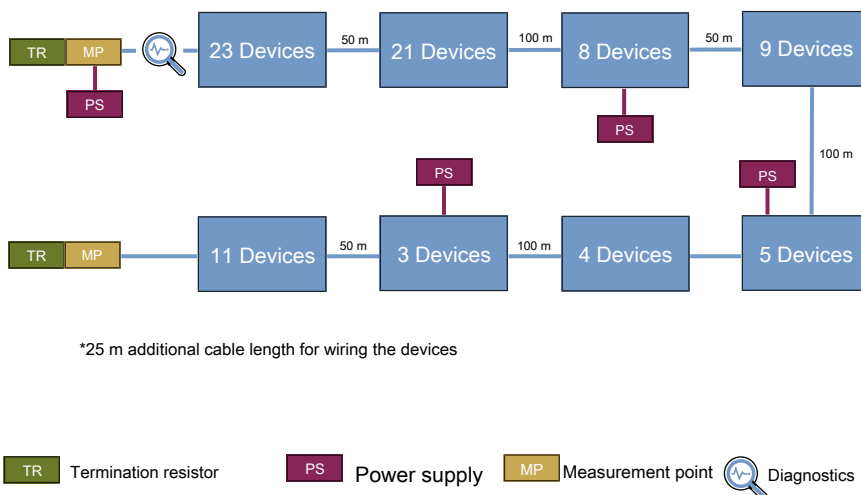

Fig. 40: 125 kbit/s, 84 devices, cable length 475 m

With 125 kbit/s, it is possible to connect up to 53 devices with a total cable length of 500 metres.

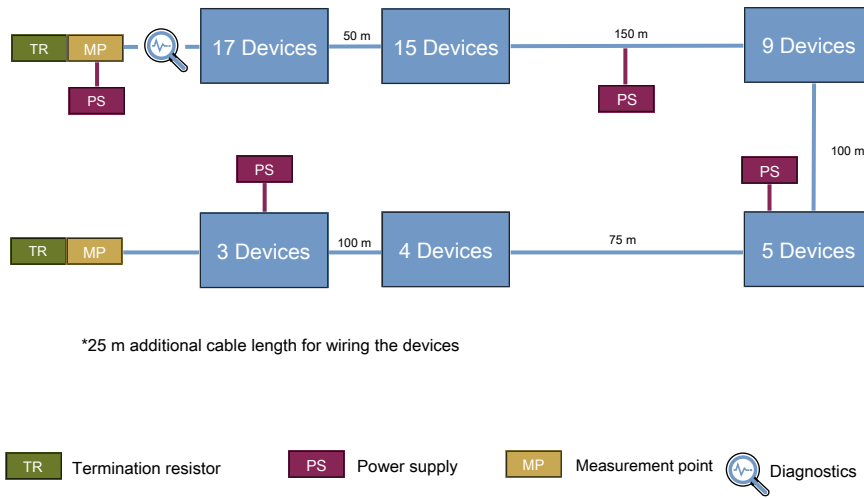

Fig. 41: 125 kbit/s, 53 devices, cable length 500 m

13.2 Star topology with a junction box

If a passive junction box is used, all the cables are stub lines. With a baud rate of 500 kbit/s, a total stub line length of 25 metres is permitted. The maximum length of each stub line is limited to 5 metres. If all the stub lines have the same length, the position of the termination resistor is irrelevant.

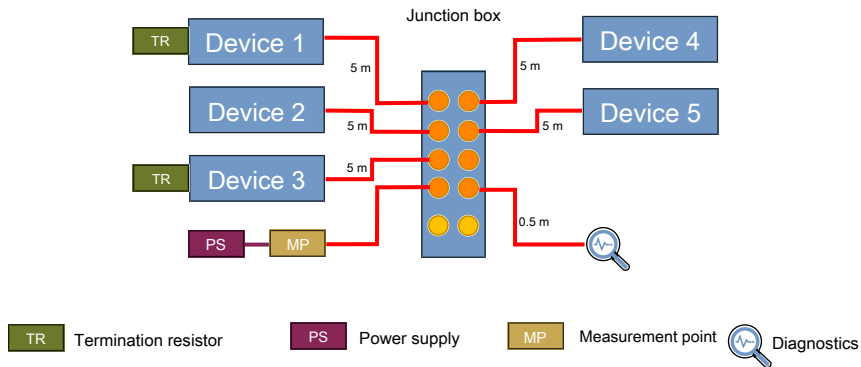

Fig. 42: Star topology with a junction box

13.3 Tree topology with a junction box

With a tree topology, a total cable length of 94 metres was measured with 23 devices in the network. The stub line length varies between 1 and 10 metres.

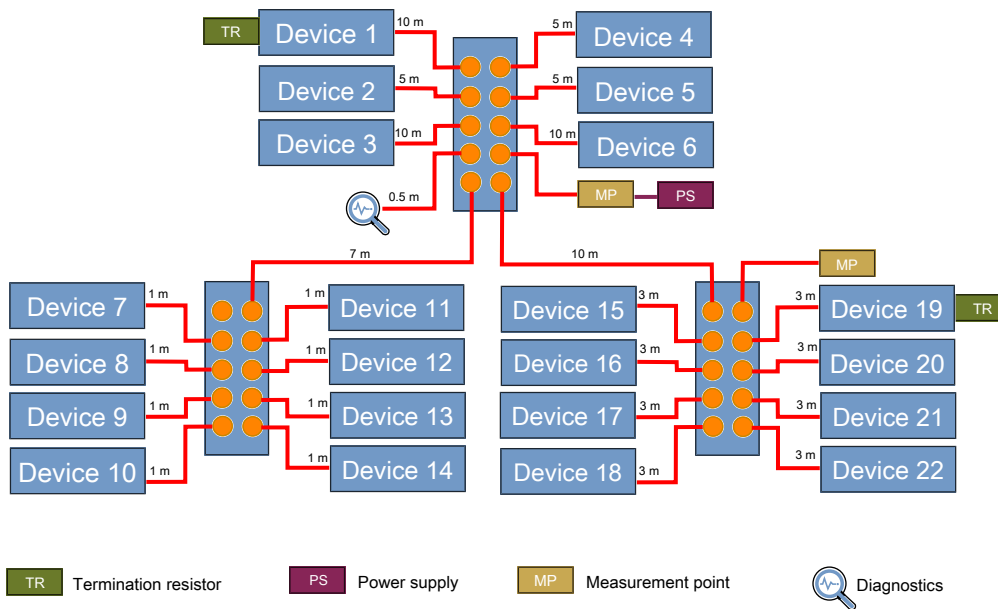

Fig. 43: Tree topology with a junction box

14 Troubleshooting

14.1 Sporadic disconnections

Description:

In a faulty network, it is possible to experience sporadic disconnections. Therefore, one or more devices may disappear for a few seconds. This is an indication that something has gone wrong.

Common problems:

- More or less than two termination resistors
- Total cable length is too long
- Total stub line length is too long
- Bus load is too high
- Undersized power supply

Solution:

- Measurement of the impedance between CAN-High and CAN-Low. The impedance should be approx. 60 Ω
- Reduce the cable length
- Reduce the baud rate to the next lower communication speed
- Create power segments in the network with more power supplies and Y-connectors

14.2 Red LED (failure)

Description:

The LED of a single device or the entire EDIP network lights up red.

Common problems:

- Incorrect connection to the PLC
- Device reached critical limit, e.g. power supply too low
- EDIP partner is missing

Solution:

- Check the cabling to the PLC and configure the PLC with the description files of the device
- Check the messages of the device with the PLC or Bürkert Communicator
- Check the partner name and mapping

14.3 Orange LED on the device (functional check)

Description:

The LED of a single device or the entire EDIP network lights up orange.

Common problems:

- Partner allocation is active
- PLC has “stopped”
- Simulation is active
- Manual mode

Solution:

- Wait until the device finds its partner in the network
- Set the PLC to “RUN”
- Deactivate simulation
- Set the device to “Automatic”

14.4 Yellow LED on the device (out of specification)

Description:

The LED of a single device or multiple devices in the network lights up yellow.

Common problems:

- Device has reached an internal limit, e.g. temperature
- Teach function is required
- Device cannot reach the setpoint

Solution:

- Check the limits and messages with the PLC or Bürkert Communicator
- Start the device teach function
- Check the medium pressure

14.5 Blue LED on the device (maintenance required)

Description:

The LED of a single device or multiple devices in the network lights up blue.

Common problems:

- Switching cycle counter limit has been reached
- Config-Provider/Client missing
- Damaged calibration curve

Solution:

- Reset the switching cycle counter
- Replace the missing device
- Recalibrate the device

14.6 Restarting some devices

If the LED first lights up yellow and then turns red or green, it is an indication that the power supply has reached a limit for stable operation. If one device switches an actor on, the voltage drop is so high that the power falls below the limit and a restart will be performed.

15 Accessories

15.1 büS accessories

Article	Order number
USB büS interface set 1: Power supply unit, büS stick, Y push-in connector, adapter cable	772426
	
USB büS interface set 2: büS stick, adapter cable	772551
büS terminating resistor (120 Ω), M12 plug, 5-pin	772424
büS terminating resistor (120 Ω), M12 socket, 5-pin	772425
büS terminating resistor (120 Ω), pluggable for backplane or ME43	303833

Tab. 8: Accessories

15.2 Software

Article	Order number
Bürkert Communicator software (type 8920)	Information at country.burkert.com
Graphical programming (activation)	567713
Batch controller for ME43 and ME63 (activation)	572948

Tab. 9: Accessories

15.3 Network accessories

Article	Order number
24 V DC power supply unit for standard rail type 1573, 1 A	772361
24 V DC power supply unit for standard rail type 1573, 1.25 A	772438
Protective cap, M12, protection for plug	917155
Adapter, Form A to M12 cable plug, A-coded	774853
24 V DC power supply unit for standard rail type 1573, 10 A	772698
Memory card (micro SD card)	774087
Protective cap, M12, protection for plug	917155
Protective plug, M12, protection for socket	774851
Protective socket, M12, protection for plug	774852
Adapter, Form A to M12 cable plug, A-coded	774853

Tab. 10: Accessories

15.4 Cable accessories

15.4.1 bÜS cable

Shielded cable, 2x 0.75 mm², 2x 0.34 mm²

Article	Order number
bÜS connection cable, M12 socket straight, 5-pin, A-coded to M12 plug straight, 5-pin, A-coded	
	
0.1 m	772492
0.2 m	772402
0.5 m	772403
1 m	772404
3 m	772405
5 m	772406
10 m	772407
20 m	772408

Tab. 11: Accessories

büS connection cable,
M12 socket straight, 5-pin, A-coded to open line end

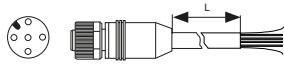

1 m	772409
3 m	772410
5 m	772411
10 m	772412

büS connection cable,
M12 socket angled, 5-pin, A-coded to open line end

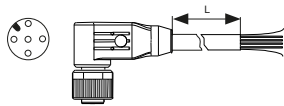

0.7 m	772626
-------	--------

büS connection cable,
open line end to open line end (cable reel)

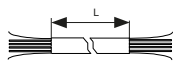

50 m	772413
100 m	772414

15.4.2 bÜS push-in connector for field wiring

Article	Order number
M12 socket straight, 5-pin, A-coded	772416
M12 socket angled, 5-pin, A-coded	772418
M12 plug straight, 5-pin, A-coded	772417
M12 plug angled, 5-pin, A-coded	772419
Y push-in connector, 5-pin, A-coded M12 socket to M12 plug and M12 socket	772420
Y push-in connector, 5-pin, A-coded, with power interruption M12 socket to 2x M12 plugs	772421
Plug adapter (gender changer), 5-pin, A-coded M12 plug to M12 plug	772867
Plug adapter (gender changer), 5-pin, A-coded M12 plug to M12 plug	775068
Plug adapter (gender changer), 5-pin, A-coded M12 socket to M12 socket	775069

Tab. 12: Accessories

15.4.3 Sensor/actuator cable

Unshielded cable, 5x 0.37 mm²

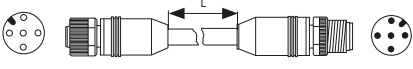
Article	Order number
Sensor/actuator cable, M12 socket straight, 5-pin, A-coded to M12 plug straight, 5-pin, A-coded	
	
0.3 m	775126
0.5 m	775127
1 m	775031
2 m	775032
3 m	775033
5 m	775034
10 m	775035
15 m	775036
20 m	775037

Tab. 13: Accessories

Sensor/actuator cable,
M12 socket angled, 5-pin, A-coded to M12 plug angled, 5-pin, A-coded

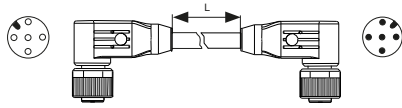

0.3 m	775128
0.5 m	775129
1 m	774797
2 m	774798
3 m	774799
5 m	774800
10 m	774801
15 m	775038
20 m	775039

Sensor/actuator cable,
M12 socket straight, 5-pin, A-coded to M12 plug angled, 5-pin, A-coded

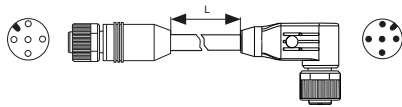

0.3 m	775276
0.5 m	774802
1 m	774803
2 m	774804
3 m	774805
5 m	774806
10 m	774807
15 m	774808
20 m	774809

Sensor/actuator cable,
M12 plug straight, 5-pin, A-coded to M12 socket angled, 5-pin, A-coded

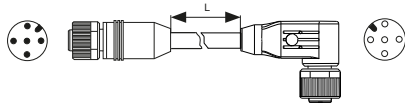

0.3 m	775185
0.5 m	775186
1 m	775187
2 m	775188
3 m	775189
5 m	775190
10 m	775191
15 m	775192
20 m	775193

15.4.4 Sensor/actuator push-in connector for field wiring

Article	Order number
M12 socket straight, 5-pin, A-coded	774812
M12 socket angled, 5-pin, A-coded	774813
M12 plug straight, 5-pin, A-coded	774814
M12 plug angled, 5-pin, A-coded	774815

Tab. 14: Accessories

15.4.5 Power cable

Unshielded cable, 5x 2.5 mm²

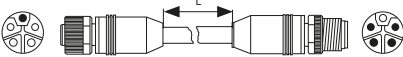
Article	Order number
Power cable, M12 socket straight, 5-pin, L-coded to M12 plug straight, 5-pin, L-coded	
	
0.1 m	774835
0.2 m	774836
0.3 m	775059
0.5 m	775060
1 m	775061
2 m	775062
3 m	775063
5 m	775064
10 m	775065
15 m	775066
20 m	775067
30 m	775312
40 m	775313
50 m	775314

Tab. 15: Accessories

Power cable,
M12 socket angled, 5-pin, L-coded to M12 plug angled, 5-pin, L-coded

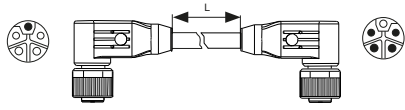

0.1 m	774837
0.2 m	774838
0.3 m	774839
0.5 m	774840
1 m	774841
2 m	774842
3 m	774843
5 m	774844
10 m	774845
15 m	774846
20 m	774847
30 m	775315
40 m	775316
50 m	775317

15.4.6 Industrial Ethernet cable

Cat5e cable

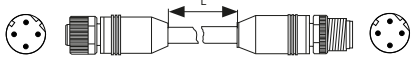
Article	Order number
Industrial Ethernet cable, M12 plug straight, 4-pin, D-coded to M12 plug straight, 4-pin, D-coded	
	
0.2 m	774816
0.3 m	774817
0.5 m	775130
1 m	775040
2 m	775041
3 m	775042
5 m	775043
10 m	775044
15 m	775045
20 m	775046
30 m	775308
40 m	775309
50 m	775310

Tab. 16: Accessories

Industrial Ethernet cable,
M12 plug angled, 4-pin, D-coded to M12 plug angled, 4-pin, D-coded

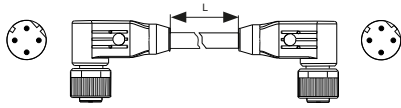

0.1 m	774818
0.2 m	774819
0.3 m	775132
0.5 m	775131
1 m	775047
2 m	775048
3 m	775049
5 m	774820
10 m	774821
15 m	774822
20 m	774823
30 m	774824
40 m	775248
50 m	775249

Industrial Ethernet cable,
M12 plug straight, 4-pin, D-coded to RJ45 connector

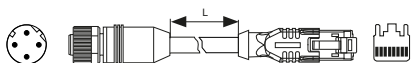

0.3 m	775133
0.5 m	775134
1 m	775050
2 m	775051
3 m	775052
5 m	775053
10 m	775054
15 m	775055
20 m	775056
30 m	775230
40 m	775287
50 m	775288

Industrial Ethernet cable,
M12 plug angled, 4-pin, D-coded to RJ45 connector

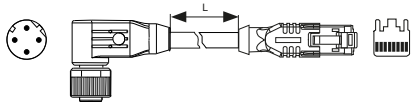

0.3 m	775135
0.5 m	774826
1 m	774827
2 m	774830
3 m	775057
5 m	775058
10 m	774831
15 m	774832
20 m	774833
30 m	775311
40 m	775289
50 m	775290

15.4.7 Ethernet push-in connector for field wiring

Article	Order number
M12 plug straight, 4-pin, D-coded	774834

Tab. 17: Accessories