

Type 8905

Online Analysis System
Online-Analyse-System
Système d'analyse en ligne



Operating Instructions

Bedienungsanleitung
Manuel d'utilisation

We reserve the right to make technical changes without notice.
Technische Änderungen vorbehalten.
Sous réserve de modifications techniques.

© Bürkert SAS, 2014–2023

Operating Instructions 2309/03_EU-ML 00566158 Original EN

1	ABOUT THE OPERATING INSTRUCTIONS	5
1.1	Symbols used.....	5
1.2	Definition of the word system.....	5
2	INTENDED USE AND EXPORTATION	6
3	BASIC SAFETY INFORMATION	7
4	GENERAL INFORMATION.....	8
4.1	Contact.....	8
4.2	Warranty conditions.....	8
4.3	Informations on the internet	8
5	DESCRIPTION	9
5.1	Area of application.....	9
5.2	Description of the type label of the system.....	9
5.3	Symbols on the device	9
5.4	Construction.....	10
5.5	Description of the electronic-modules housing	11
5.6	Description of the sensor-cubes housing.....	12
5.7	Description of the backplanes for the sensor cubes	13
5.8	Description of the touchscreen	14
5.9	Description of the system status light	14
6	TECHNICAL DATA	15
6.1	Conditions of use.....	15
6.2	Standards and directives	15
6.3	Electrical data of a system with an AC switched-mode power supply.....	16
6.4	Electrical data of a system energized with a direct voltage power supply.....	16
6.5	Mechanical data.....	17
6.6	Fluid data.....	17

7	INSTALLATION.....	18
7.1	Safety instructions	18
7.2	Installing the system on a support.....	19
7.3	Opening a housing.....	20
7.4	Mounting a sensor cube on a sensor cube backplane	21
7.5	Doing the fluidic installation	22
7.6	Electrical wiring.....	24
7.6.1	Terminal assignment of the terminal blocks	24
7.6.2	Pin assignment of the M12 connectors.....	25
7.6.3	Connecting a V AC version to the mains.....	26
7.6.4	Doing the electrical installation of a system with a V DC power supply.....	29
7.6.5	Connecting the system to a CANopen interface	29
7.7	Removing a sensor cube from the backplane.....	30
7.8	Closing a housing	30
8	ADJUSTMENT, OPERATION	31
8.1	Safety instructions	31
8.2	Before commissioning the system.....	31
9	MAINTENANCE AND TROUBLESHOOTING	32
9.1	Safety instructions	32
9.2	Cleaning of the system	32
9.3	Maintenance on a component.....	32
9.4	Troubleshooting	33
10	SPARE PARTS AND ACCESSORIES	33
11	PACKAGING, TRANSPORT.....	34
12	STORAGE	34
13	DISPOSAL	34

1 ABOUT THE OPERATING INSTRUCTIONS

The Operating Instructions describe the entire life cycle of the system. Please keep the Operating Instructions in a safe place, accessible to all users and any new owners.

The Operating Instructions manual contains important safety information.

Failure to comply with the instructions can lead to hazardous situations.

- ▶ The Operating Instructions must be read, understood and followed.
- ▶ Read the Operating Instructions carefully when the  symbol appears in or out the system.

1.1 Symbols used

DANGER

Warns against an imminent danger.

- ▶ Failure to observe this warning can result in death or in serious injury.

WARNING

Warns against a potentially dangerous situation.

- ▶ Failure to observe this warning can result in serious injury or in death.

CAUTION

Warns against a possible risk.

- ▶ Failure to observe this warning can result in substantial or minor injuries.

NOTE

Warns against material damage.

- ▶ Failure to observe this warning may result in damage to the system.

 Indicates additional information, advice or important recommendations.

 Refers to information contained in this manual or in other documents.

▶ Indicates an instruction to be carried out to avoid a danger.

→ Indicates a procedure to be carried out.

1.2 Definition of the word system

The word "system" used in the Operating Instructions always refers to the Online Analysis System type 8905.

2 INTENDED USE AND EXPORTATION

Use of the system that does not comply with the instructions could present risks to people, nearby installations and the environment.

- ▶ The measurement system type 8905 is intended, depending on the sensor cubes and the electronic modules fitted, for the acquisition, processing, transmission and regulation of physico-chemical parameters such as pH, oxydoreduction potential, conductivity, temperature, turbidity or chlorine rate in drinking water.
- ▶ The measurement system type 8905 must never be used in safety applications.
- ▶ Only combine the system with third-party devices or components recommended and authorized by Bürkert.
- ▶ The system must be protected against electromagnetic interference, ultraviolet rays and, when installed outdoors, the effects of climatic conditions.
- ▶ The system must be used in compliance with the characteristics and commissioning and use conditions specified in the contractual documents and in the Operating Instructions.
- ▶ The system must be used in compliance with the characteristics and commissioning and use conditions specified in the Operating Instructions of all the electronic modules and of all the sensor cubes that are used in the system.
- ▶ Requirements for the safe and proper operation of the system are proper transport, storage and installation, as well as careful operation and maintenance.
- ▶ Only use the system as intended.

3 BASIC SAFETY INFORMATION

This safety information does not take into account:

- any contingencies or occurrences that may arise during assembly, use and maintenance of the system.
- the local safety regulations that the operator must ensure the staff in charge of installation and maintenance observe.



Danger due to electrical voltage.

- ▶ Shut down the electrical power source of all the conductors and isolate it before carrying out work on the system.
- ▶ Observe all applicable accident protection and safety regulations for electrical equipment.

Risk of injury due to high pressure in the installation.

- ▶ Stop the circulation of fluid, cut off the pressure and drain the pipe before loosening the process connections.



Various dangerous situations.

To avoid injury take care:

- ▶ to carry out the installation and maintenance work by qualified and skilled staff with the appropriate tools.
- ▶ to use the system only if in perfect working order and in compliance with the instructions provided in the Operating Instructions.
- ▶ not to use the system in explosive atmospheres.
- ▶ not to use the system in an environment incompatible with the materials from which it is made.

To avoid damage to the system:

- ▶ do not make any modification to the system.
- ▶ do not subject the system to mechanical loads (e.g. by placing objects on top of it or by using it as a step).
- ▶ only use the system as intended.

NOTE

Elements / Components sensitive to electrostatic discharges

- ▶ The system contains electronic components sensitive to electrostatic discharges. They may be damaged if they are touched by an electrostatically charged person or object. In the worst case scenario, these components are instantly destroyed or go out of order as soon as they are activated.
- ▶ To minimise or even avoid all damage due to an electrostatic discharge, take all the precautions described in the EN 61340-5-1 norm.
- ▶ Also ensure that you do not touch any of the live electrical components.

4 GENERAL INFORMATION

4.1 Contact

To contact the manufacturer of the system use following address:

Bürkert SAS

Rue du Giessen

BP 21

F-67220 TRIEMBACH-AU-VAL

The addresses of our international branches can be found on the Internet at: country.burkert.com.

4.2 Warranty conditions

The condition governing the legal warranty is the conforming use of the system in observance of the operating conditions specified in the Operating Instructions.

4.3 Informations on the internet

You can find the Operating Instructions and technical data sheets regarding the type 8905 at: country.burkert.com.

5 DESCRIPTION

5.1 Area of application

The system type 8905 is intended, depending on the sensor cubes and the electronic modules fitted, for the acquisition of physico-chemical parameters such as pH, oxydoreduction potential, conductivity, temperature, turbidity or chlorine rate in drinking water.

5.2 Description of the type label of the system

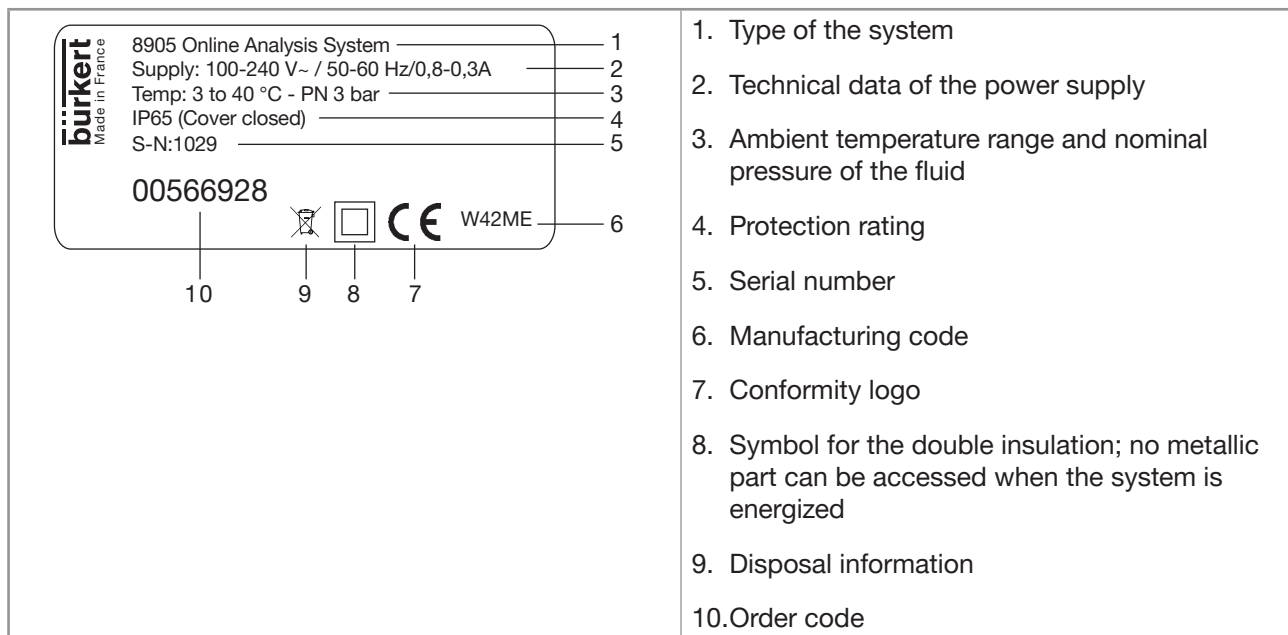

Fig. 1: Type label (example)

5.3 Symbols on the device

Symbol	Description
	Direct current
	Alternating current
	Earth terminal
	Protective conductor terminal

5.4 Construction

The system is made of 2 housings that are attached together. It can be installed on a support with the delivered wall bracket.

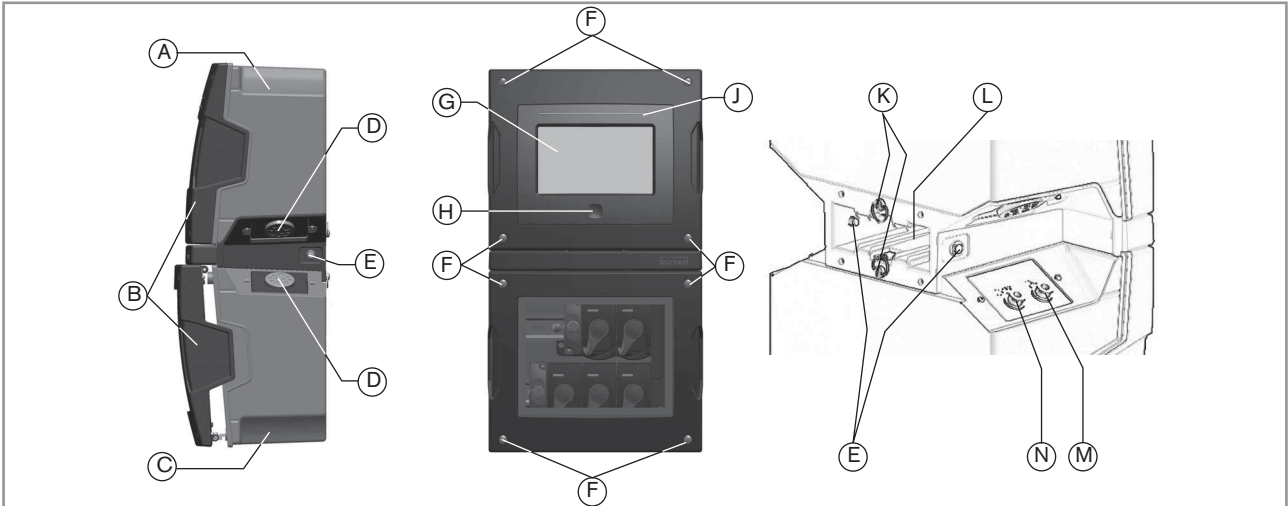

A: Housing which contains the electronic modules. See chapter 5.5.

B: Covers of the housings

C: Housing which contains the sensor cubes. See chapter 5.5.

D: Cable entry plates for electrical cables

E: Lockers, on both sides of the housing, to lock the system to the wall bracket

F: Quarter-turn studs

G: Touchscreen. See the Operating Instructions of the Display software type ME21, available on the CD delivered with the system and on the Bürkert website.

H: Button

J: System status light according to the Namur standard NE107

K: Quarter-turn studs with bail handles

L: Seating for the wall bracket

M: IN: Fluid inlet; connection for a flexible hose, 6 mm in diameter

N: OUT: Fluid outlet; connection for a flexible hose, 6 mm in diameter

Fig. 2: Construction of the system

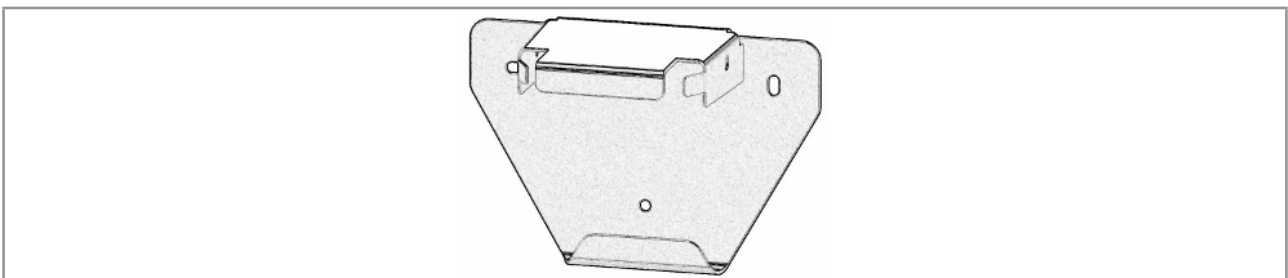

Fig. 3: Wall bracket

5.5 Description of the electronic-modules housing

The main parts of the sensor cube housing are described in [Fig. 4](#).

The system has a customer specific configuration.

Depending on the system configuration, refer to the Operating Instructions of the electronic modules to get the following information:



- the complete description of the electronic modules,
- the technical data of the electronic modules,
- the adjustment related to the electronic modules,
- the maintenance of the electronic modules.

You can find the Operating Instructions of the electronic modules that equip the system on the CD provided with the system.

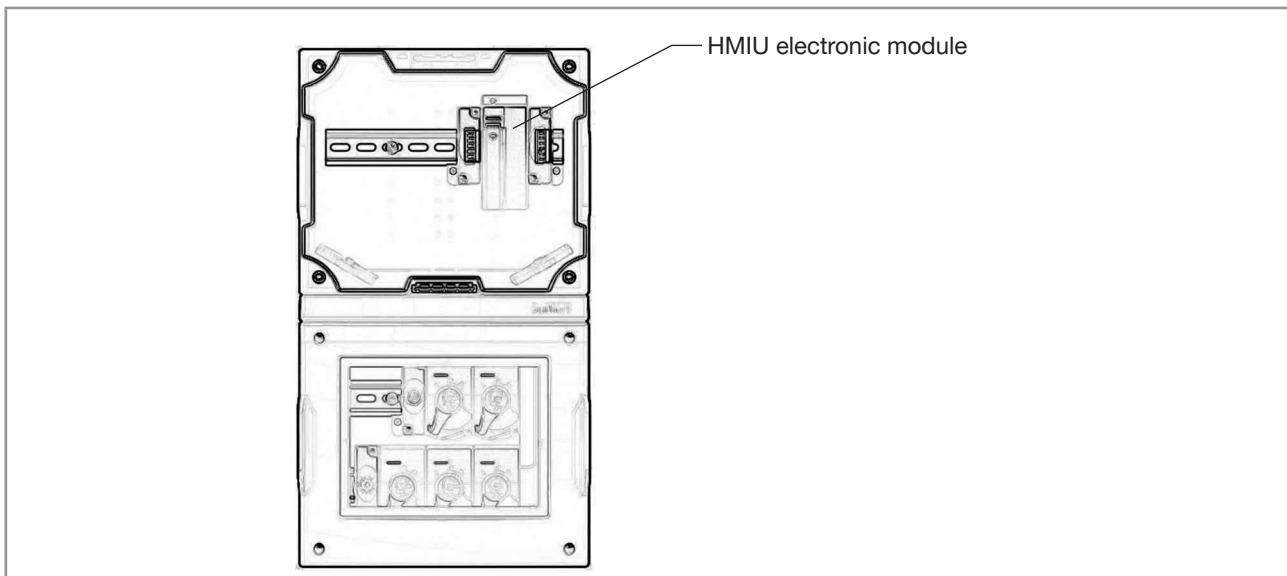

Fig. 4: *Electronic-modules housing (example of a system with 1 electronic module and no switched-mode power supply)*

5.6 Description of the sensor-cubes housing

The main parts of the sensor cube housing are described in [Fig. 5](#).

The system has a customer specific configuration.

The basic system contains five sensor cubes. The sensor cubes all have the same dimensions:

- a pH and temperature sensor cube
- an ORP (redox potential) sensor cube
- a conductivity and temperature sensor cube
- a turbidity sensor cube
- a chlorine and temperature sensor cube

Depending on the system configuration, refer to the Operating Instructions of the sensor cubes to get the following information:



- the complete description of the sensor cubes,
- the technical data of the sensor cubes,
- the adjustment related to the sensor cubes,
- the maintenance of the sensor cubes.

You can find the Operating Instructions of the sensor cubes that equip the system on the CD provided with the system.

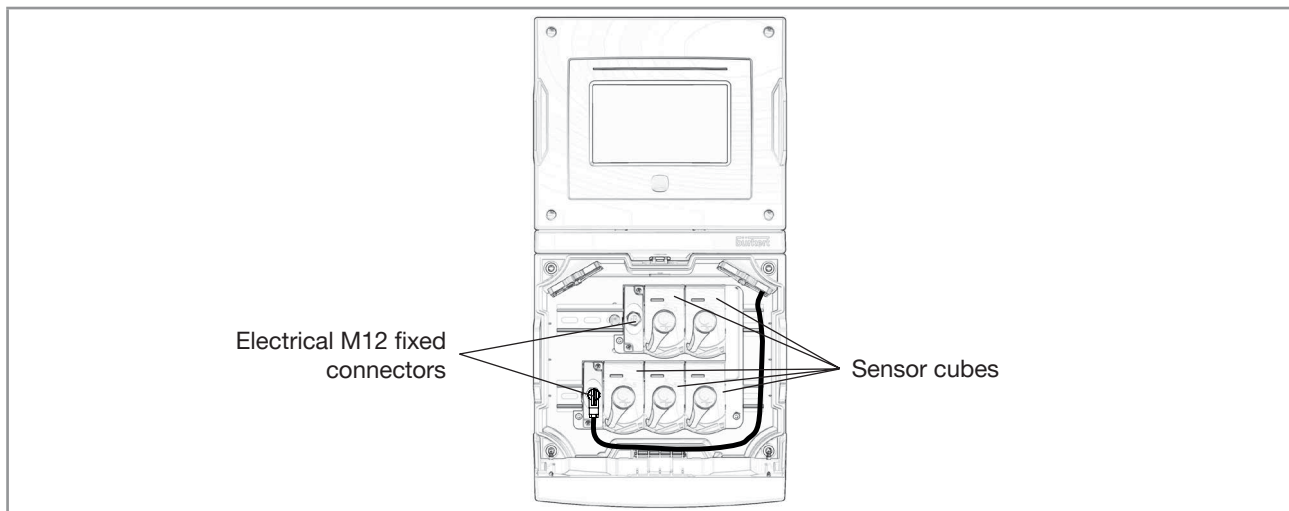

Fig. 5: Sensor-cubes housing (example with five sensor cubes)

A sensor cube is identified by a specific logo on its push-button:

Logo on the push-button					
Measured physical quantity	pH and temperature	Redox potential	Conductivity and temperature	Turbidity	Chlorine and temperature

5.7 Description of the backplanes for the sensor cubes

Each sensor cube is plugged on a sensor cube backplane.

All the backplanes for the sensor cubes have the same design. Thus any sensor cube can be plugged on any sensor cube backplane in the system.

The backplanes are connected to each other and feed the sensor cubes with the power supply and the process water.

The backplanes are connected in parallel, i.e. if a sensor cube is removed, the other sensor cubes continue measuring.

When the sensor cube is removed from its backplane, the interface is tight.

A locking pin prevents from unintentional move of the bayonet lever.



DANGER

Risk of injury due to the nature of the fluid if no sensor cube is plugged on a backplane.

If the fluid outlet of the backplane is open, fluid may splash on you.

- The fluid outlet must stay closed if the backplane has no sensor cube.
- Do not move the bayonet lever with the hand.

NOTE

The backplane may be damaged if no sensor cube is plugged on a backplane.

A short-circuit may damage the backplane if the electrical contacts are touched with a conductive material.

- ▶ Do not touch the electrical contacts.
- ▶ Cover the electrical contacts with a correct protection cap: contact the manufacturer.

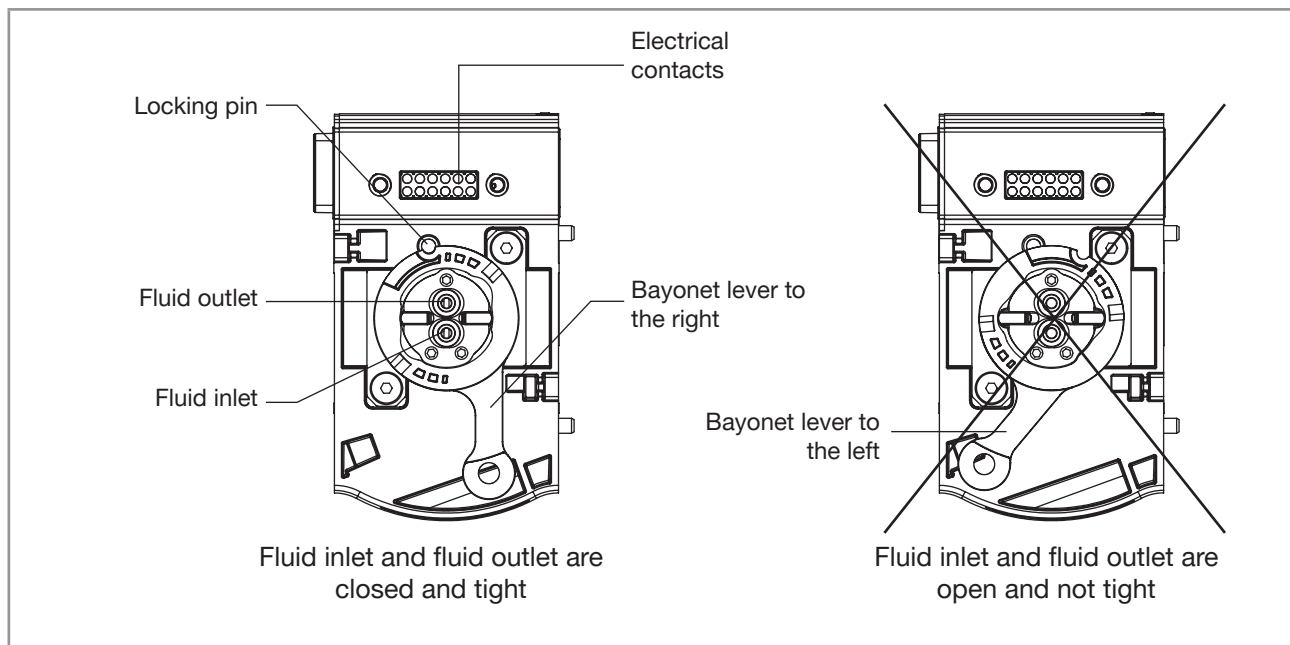

Fig. 6: Description of a sensor cube backplane

5.8 Description of the touchscreen

The system has a touchscreen to parameterize the system and to display the monitored parameters.

You can find the Operating Instructions of the touchscreen on the CD provided with the system.

5.9 Description of the system status light

The light that indicates the status of the system changes its color and status in accordance with NAMUR NE 107.

If several statuses exist simultaneously, the status with the highest priority is displayed. The priority is determined by the severity of the deviation from standard operation (red LED = error = highest priority).

Table 1: Description of the system status light

Display in accordance with (NE 107)		Description	Meaning
Color	Red	Error	Malfunction System function is not ensured.
	Orange	Warning	Ambient or process conditions for the system are outside the permitted ranges. The system may be damaged.
	Yellow	Out of specification	Ambient or process conditions for the system are outside the permitted ranges. Technical data cannot be complied with.
	Blue	Maintenance required	Based on a running diagnostic, the system has detected and corrected a deviation. System functionality restricted.
	Green	Diagnostic active	System functionality disabled. Execution of diagnostic functions.
	White	Normal operation	System is running within its specifications.
State	Illuminated	System is in AUTOMATIC operating state.	System is in standard operation.
	Flashing	System is in HAND/ MANUAL operating state	System in manual operation.
	Flashing rapidly	Identification	Serves for identification of a device in the büS network. The system was selected using the "Bürkert Communicator" software or on the display.

6 TECHNICAL DATA

6.1 Conditions of use

The system is suited for industrial use and not for domestic use.

Ambient temperature	3...+40 °C
Air humidity	< 95 %, without condensation
Protection rating according to EN 60529	IP65, with closed and locked casings
Maximum height above sea level	2000 m
Degree of pollution	Degree 2, with closed and locked casings
Category of installation of a system with an AC switched-mode power supply	Category II according to UL 61010-1
Category of installation of a system energized with a direct voltage power supply	Category I according to UL 61010-1

6.2 Standards and directives

The device complies with the relevant EU harmonisation legislation. In addition, the device also complies with the requirements of the laws of the United Kingdom.

The harmonised standards that have been applied for the conformity assessment procedure are listed in the current version of the EU Declaration of Conformity/UK Declaration of Conformity.

Conformity to the Pressure Equipment Directive

- Pressure Equipment Directive 2014/68/EU, article 4 §1

The system can only be used under the following conditions (depending on the PN = maximum admissible pressure in bar, the DN = nominal diameter of the pipe in mm, and the type of fluid):

Type of fluid	Conditions
Fluid group 1, article 4 §1.c.i	DN ≤ 25
Fluid group 2, article 4 §1.c.i	DN ≤ 32 or DN > 32 and PNxDN ≤ 1000
Fluid group 1, article 4 §1.c.ii	DN ≤ 25 or PNxDN ≤ 2000
Fluid group 2, article 4 §1.c.ii	DN ≤ 200 or PN ≤ 10 or PNxDN ≤ 5000

6.3 Electrical data of a system with an AC switched-mode power supply

Operating voltage	100...240 V AC
Frequency	50...60 Hz
Current consumption at 100 V AC	0.8 A
Current consumption at 240 V AC	0.3 A
Integrated current limiting fuse	A slow blow 2A-fuse. The fuse cannot be replaced and is integrated in the power supply.

6.4 Electrical data of a system energized with a direct voltage power supply

Operating voltage	20...30 V DC
20...30 V DC power source (not supplied)	<ul style="list-style-type: none"> • Filtered and regulated • SELV circuit, at a non-hazardous energy level • Tolerance: $\pm 10\%$
Maximum power consumption	96 VA

6.5 Mechanical data

Weight: approximately 8 kg (configuration with the 100...240 V AC switched-mode power supply unit, the HMIU electronic module and 5 sensor cubes); up to 12 kg if the system is completely equipped.

Dimensions: refer to the data sheet related to the system and available under country.burkert.com.

Table 2: *Materials the system is made of*

Part	Material
Housings	PC, black, UV stabilized, UL94 V0
Cover of the housing which contains the electronic modules	PC, glass fibre reinforced, UV stabilized, UL94 V0, charcoal grey
Cover of the housing which contains the sensor cubes	<ul style="list-style-type: none"> • PC, transparent • PC, glass fibre reinforced, UV stabilized, UL94 V0, charcoal grey
Studs	Stainless steel
Cable entry plate	Elastomer
Fluid connections	Biopolymer (EPDM seals)
Wall bracket	Stainless steel
Self-adhesive bumpers	Polyurethane

6.6 Fluid data

→ Refer to the Operating Instructions of all the sensor cubes.

→ Apply the most restrictive values given in the Operating Instructions of the sensor cubes.

7 INSTALLATION

7.1 Safety instructions



DANGER

Danger due to electrical voltage.

- ▶ Shut down the electrical power source of all the conductors and isolate it before carrying out work on the system.
- ▶ Observe all applicable accident protection and safety regulations for electrical equipment.

Risk of injury due to high pressure in the installation.

- ▶ Stop the circulation of fluid, cut off the pressure and drain the pipe before loosening the process connections.



WARNING

Risk of injury due to non-conforming installation.

- ▶ Electrical and fluidic installations can only be carried out by qualified and authorised personnel with the appropriate tools.
- ▶ Fit a circuit breaker or a switch to the electrical installation of the building in which the system is installed.
- ▶ Install the circuit breaker or the switch in an easily accessible place.
- ▶ Identify the circuit breaker or the switch as the disconnecting component for the electrical power supply to the system.
- ▶ Install overload devices that are appropriate to the electrical installation. For a version powered by 100...240 V AC, connect a 6 A to 16 A rated fuse, in the phase conductor (L) and in the neutral conductor (N).
- ▶ Do not power the 20...30 V DC version of the system with an AC voltage or with a DC voltage higher than 30 V DC.
- ▶ Do not power the 100...240 V AC version with a DC voltage or with an AC voltage higher than 240 V AC.
- ▶ Observe standard NF C 15-100 / IEC 60634.

Risk of injury due to unintentional switch on of power supply or uncontrolled restarting of the installation.

- ▶ Avoid unintentional activation of the installation.

NOTE

Risk of damage to the system due to the environment

- ▶ Protect the system against electromagnetic interference, ultraviolet rays and, when installed outdoors, the effects of the climatic conditions.

7.2 Installing the system on a support

The system must be installed on a support (a wall for example) with the wall-mounting set with order code 566363, including 1 wall bracket and the 4 self-adhesive bumpers.

 <p>Self-adhesive bumpers</p>	<p>→ Install the 4 self-adhesive bumpers on the rear side of the system housing:</p> <ol style="list-style-type: none"> 1. With a degreasing agent, clean the four surfaces where the self-adhesive bumpers will be cemented to the housing. 2. Let the surfaces dry. 3. Remove the self-adhesive bumpers from their support and press them on the cleaned surfaces.
 <p>Locker</p> <p>Locker housing</p> <p>300 mm</p> <p>200 mm</p>	<ol style="list-style-type: none"> 4. Weigh the system and make sure the support is stable enough for the system. 5. Choose a mounting location to have the display at eye level. 6. Make sure there is a minimal clearance of 300 mm above the wall bracket and a minimal clearance of 200 mm below the wall bracket. 7. Prepare screws that can support the weight of the system. If necessary insert wall plugs in the support.
 <p>112,5</p> <p>70</p> <p>Ø 6,5</p>	<ol style="list-style-type: none"> 8. Drill three holes into the support with respect to the drilling plan. 9. Attach the wall bracket to the support with screws. 10. Put the system on the wall bracket until the lockers engage into their housings.

Fig. 7: Installing the system on a support, with the wall-mounting set

7.3 Opening a housing

The opening of the 2 housings is made in the same way.

DANGER

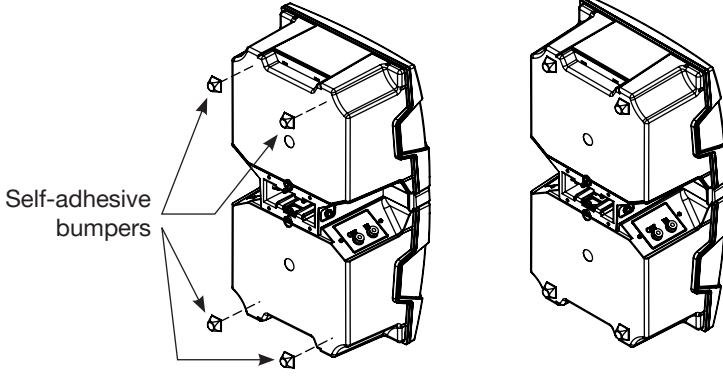
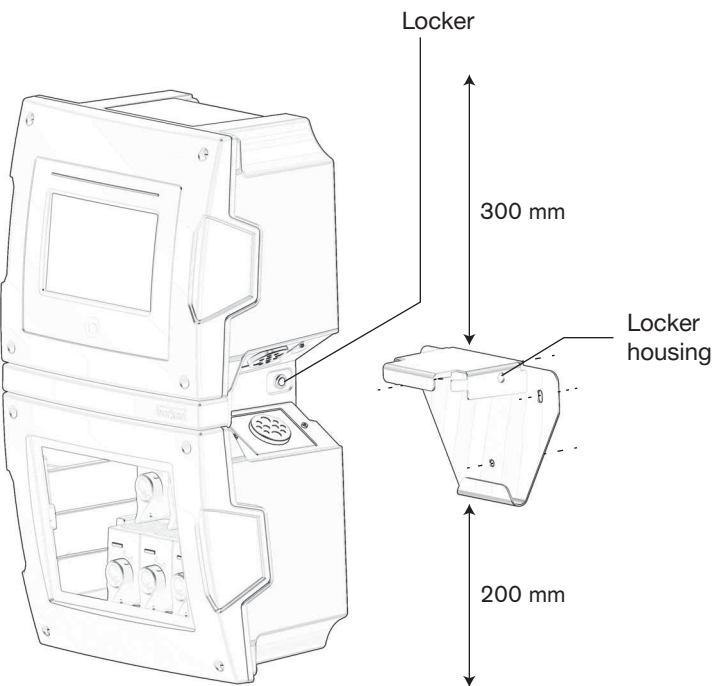
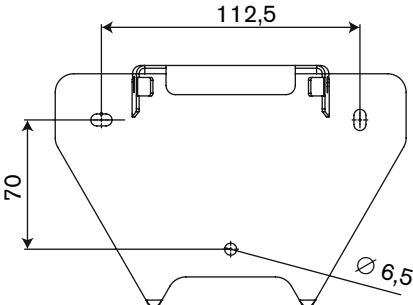
Risk of electrocution if the electronic-modules housing is open, because its IP65 protection is not ensured.

- ▶ Only open the electronic-modules housing to put in or remove the USB stick from the electronic module ME21 or ME25.
- ▶ Before opening the electronic-modules housing, protect the system against any splashing.
- ▶ Close the housing after any work with respect to the closing instructions of the housing.

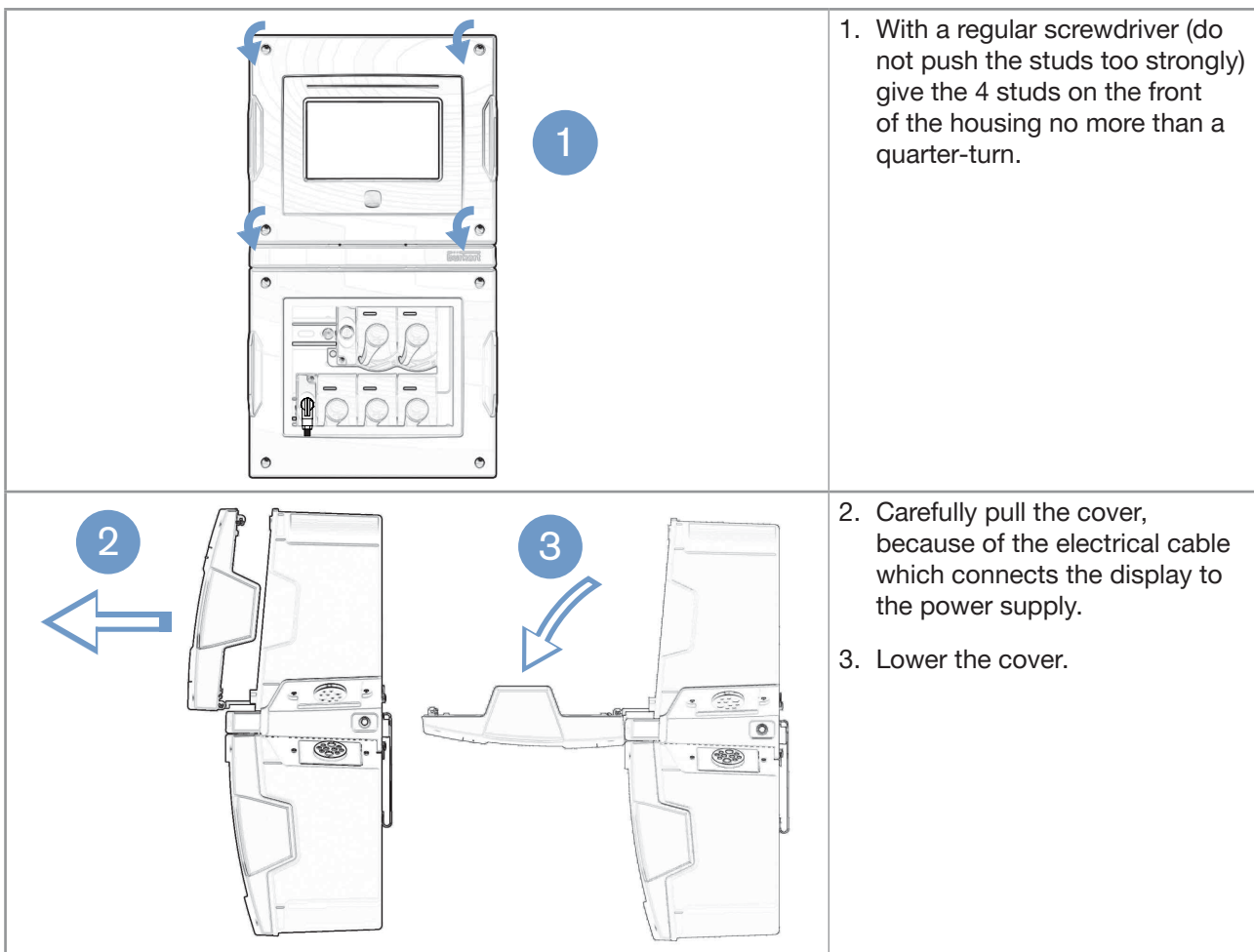

Fig. 8: Opening a housing

7.4 Mounting a sensor cube on a sensor cube backplane

The sensor cube is plugged in a sensor cube backplane of the system.

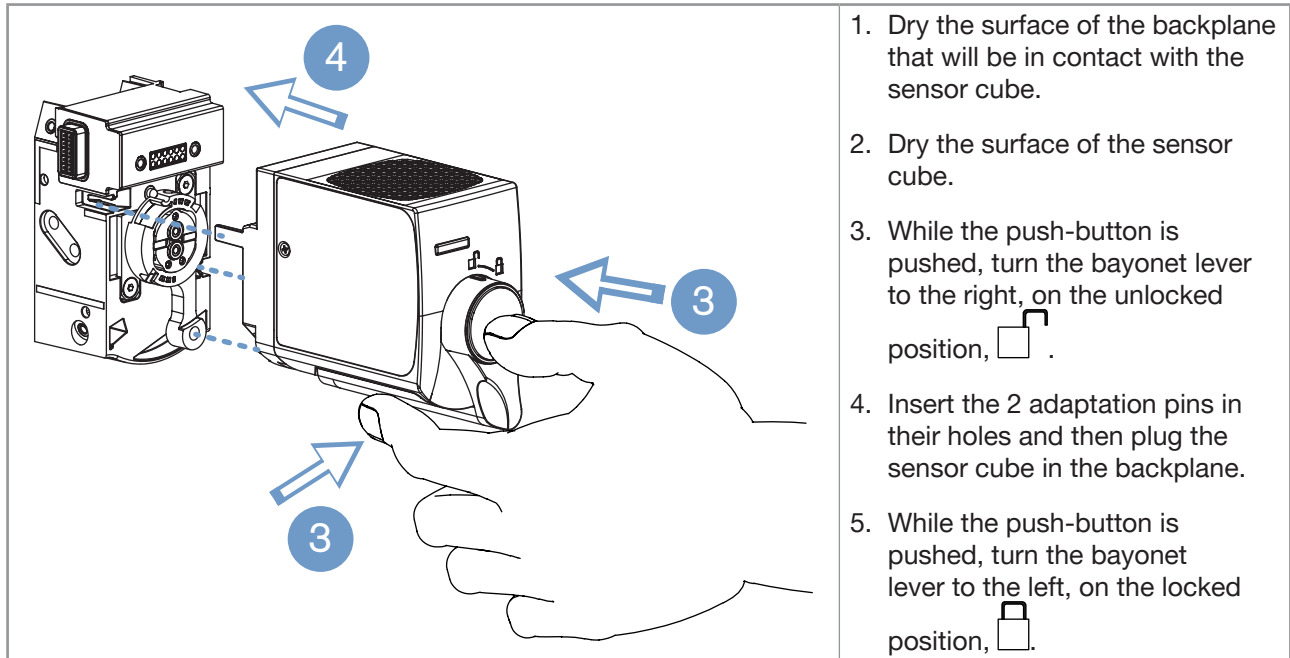

Fig. 9: Mounting a sensor cube on the backplane of the system

7.5 Doing the fluidic installation

The following figure shows how the fluid flows through the fluidic backplanes and the sensor cubes, if at least one sensor cube is plugged in.

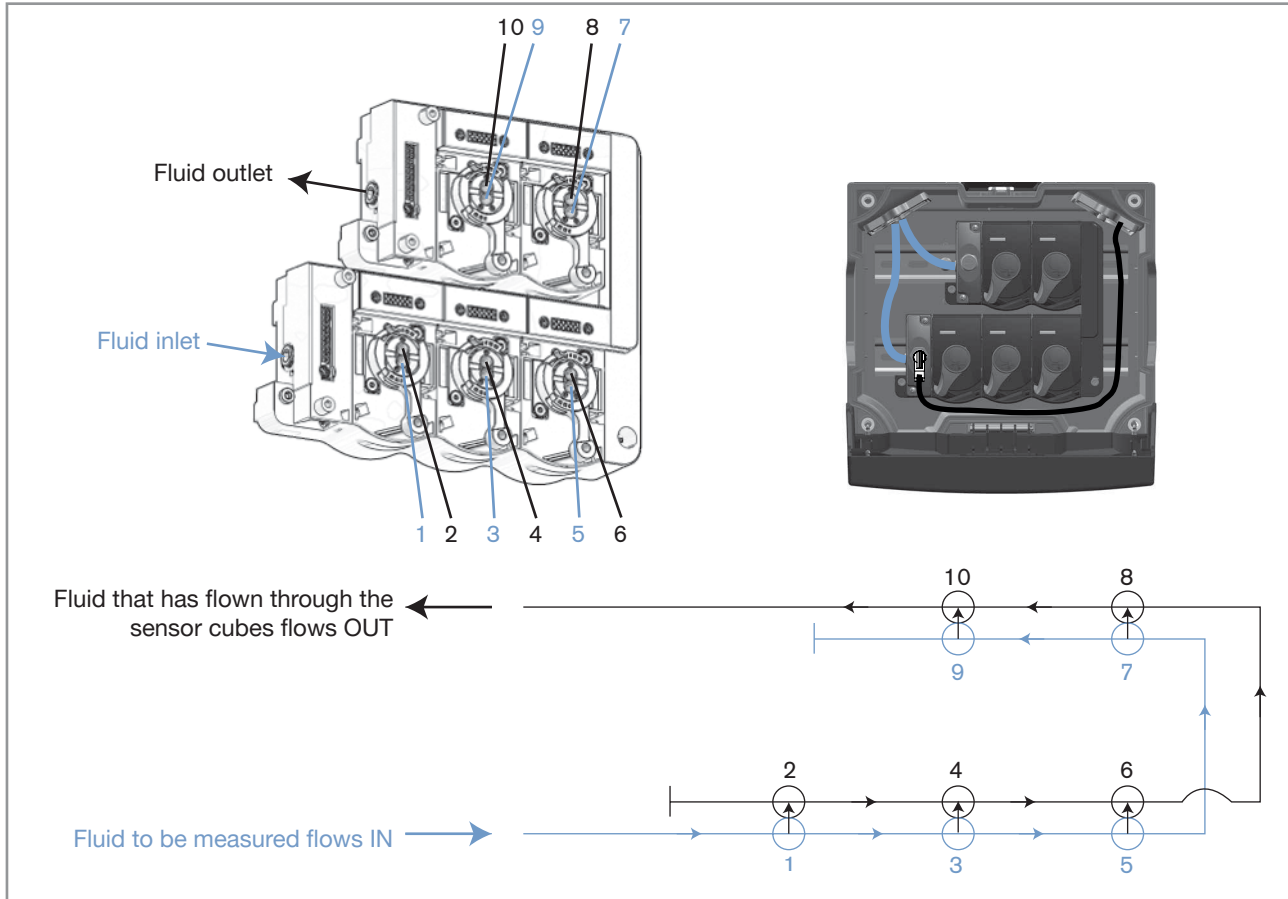

Fig. 10: Principle of the fluid circulation in the fluidic backplanes and the sensor cubes

The fluidic connections in the sensor-cubes housing are done in the factory.

→ Outside the housing, connect the flexible hoses, 6 mm in diameter, to the water inlet and to the water outlet, as described in [Fig. 12](#).

CAUTION

Unwanted development of bacterium when using non opaque flexible hoses.

- ▶ Use opaque flexible hoses, preferably in PE, PTFE or PVDF, to do the fluidic connections.
- ▶ Do not use flexible hoses in PVC.

→ To respect the PN3 or PN6 water pressure in the system, install a pressure reducer with its pressure gauge in the inlet path of the system:

- the strainer is used to remove unwanted particles from the water.
- the pressure gauge is used to indicate the pressure of the water downstream the pressure reducer and upstream the system.

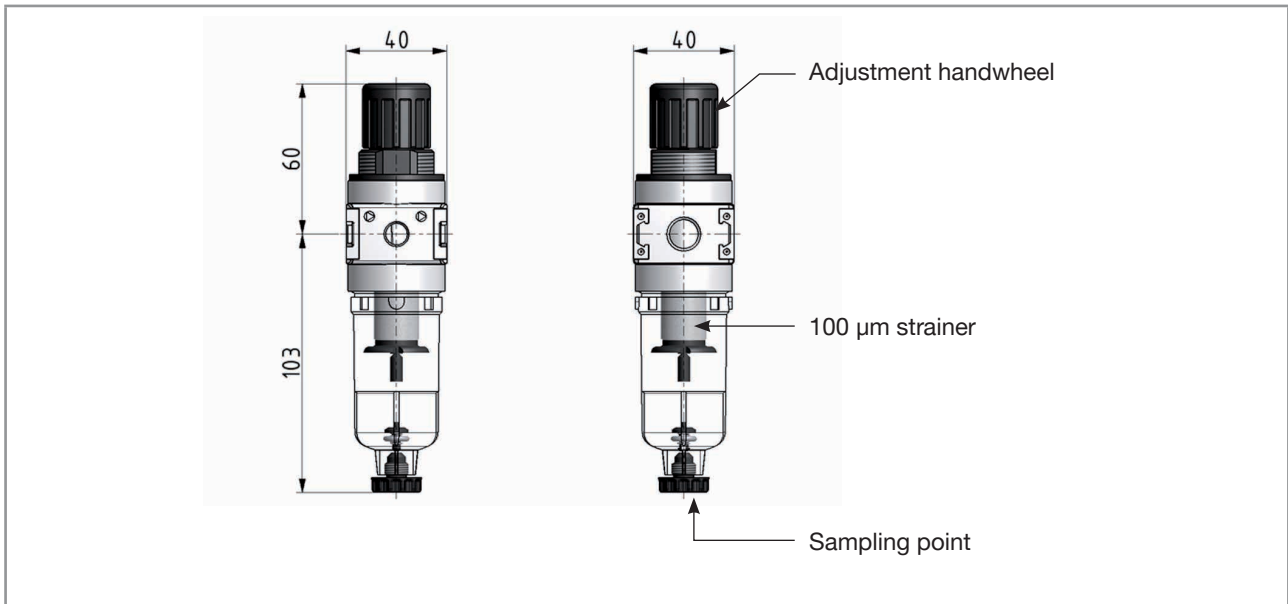

Fig. 11: Pressure reducer available as an accessory

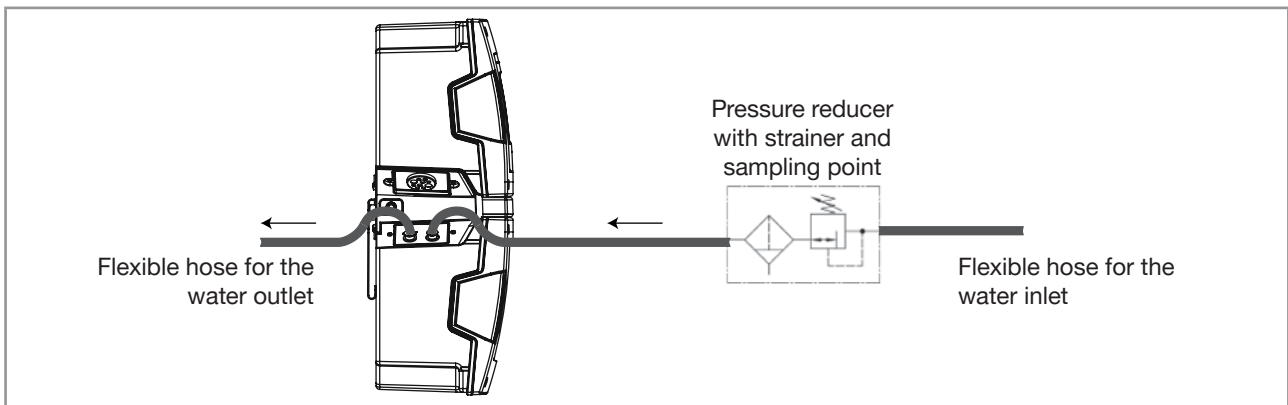

Fig. 12: Connection of the flexible tubing, outside the housing

7.6 Electrical wiring

7.6.1 Terminal assignment of the terminal blocks

Two terminal blocks come with the box containing the electronic modules:

- the male terminal block, which is used to connect the power supply to the system;
- the female terminal block, which feeds the power supply to the sensor modules.

Assignment of the terminal blocks is the same for both terminal blocks, male and female.

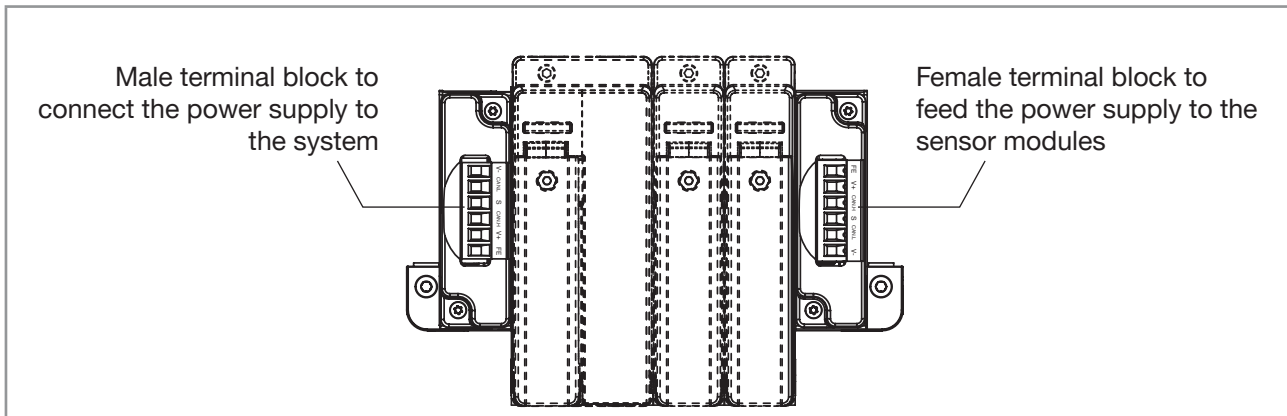

Fig. 13: Position of the terminal blocks

Table 3: Assignment of the terminals on the two terminal blocks

Marking on the terminal	Signal	Male terminal block	Female terminal block
V-	0 V / GND		
CAN.L	CAN_L		
S	CAN_SHIELD		
CAN.H	CAN_H		
V+	V+		
FE	Functional earth		

7.6.2 Pin assignment of the M12 connectors

Two M12 connectors come with the box containing the sensor modules:

- the male M12 connector, which connects the power supply for the sensor modules. In an 8905 system, the power supply is fed via the box with the electronic modules;
- the female M12 connector, which feeds the power supply to an external device.

Pin assignment is the same for both M12 connectors.

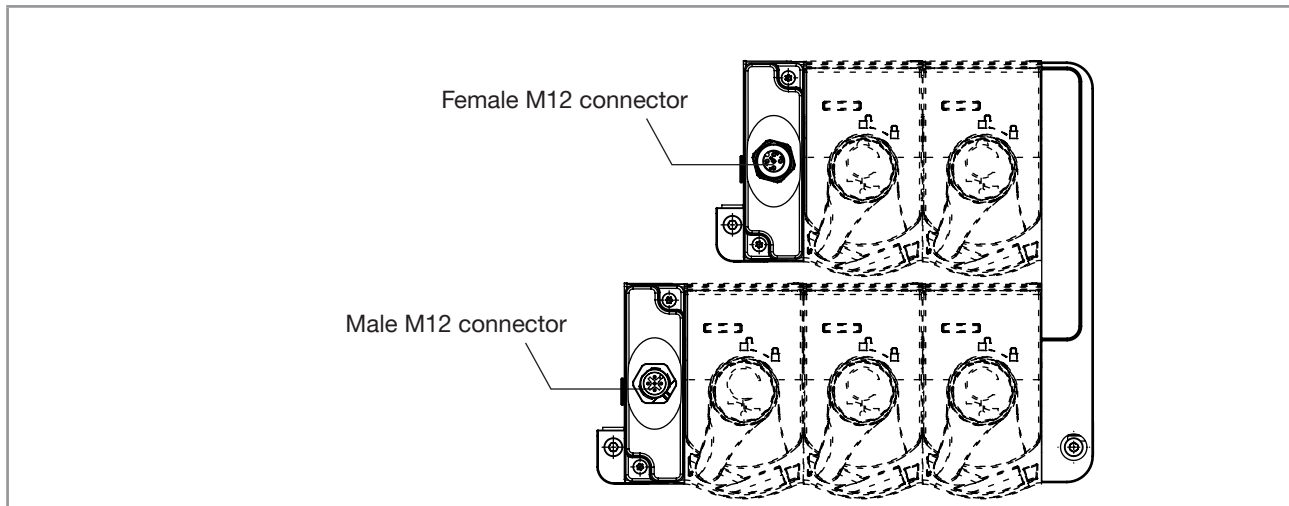

Fig. 14: Position of the M12 connectors

Table 4: Pin assignment of the two M12 connectors

Pin number	Signal	Colour of the conductor (cable coming from the box containing the electronic modules)	
1	CAN_SHIELD	-	
2	V+	Red	
3	0 V / GND	Black	
4	CAN_H	White	
5	CAN_L	Blue	

7.6.3 Connecting a V AC version to the mains

! DANGER

Risk of electrocution if the switched-mode power supply is not covered with the protective cover.

- ▶ Always place the switched-mode power supply in its original position on the DIN rail.

The switched-mode power supply of the system converts the alternating supply voltage from the mains in a 24 V DC supply voltage.

The 24 V DC supply voltage feeds the electronic modules and the sensor cubes.

The wiring between the switched-mode power supply and the terminal block is made at the factory according to [Fig. 15](#).

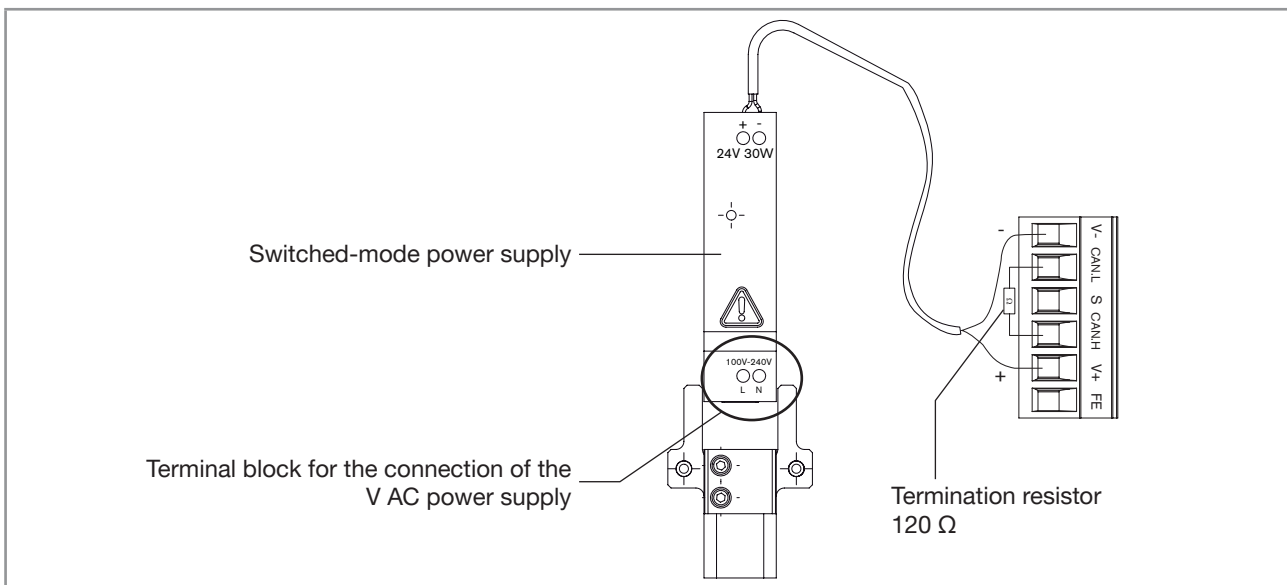

Fig. 15: Factory-made wiring of the terminal block

→ Use a cable with the specifications described in [Table 5](#) to connect the V AC power supply to the terminal block of the switched-mode power supply.

Table 5: Specifications of the cable and the wires

Cable model	H05 VV-F
External diameter of the cable	6...7.5 mm
Cross section of a rigid wire	0.75...1.5 mm ² , 8 mm exposed
Cross section of a flexible wire	0.75...1.5 mm ² , 8 mm exposed
Operating temperature of the cable	> +90 °C

→ Prepare the following tools for the wiring:

- 1 regular screwdriver with a 5.5 mm tip width
- 1 regular screwdriver with a 2.5 mm tip width
- 1 hex key 2.5 mm

→ Follow the instructions from [Fig. 16](#) to connect the system to the VAC-power supply.

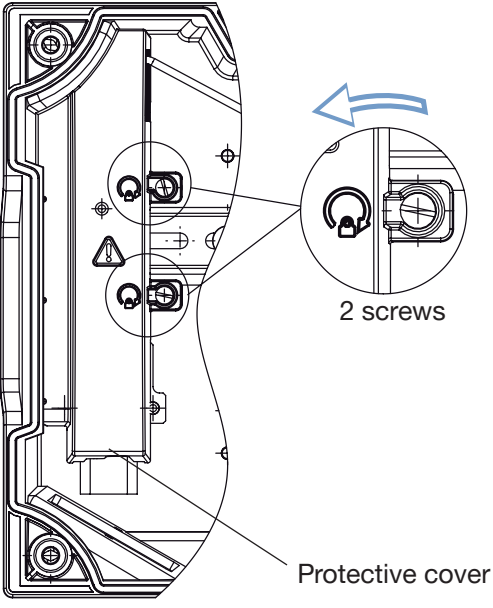
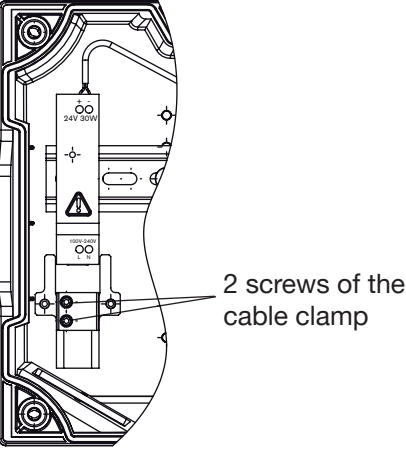
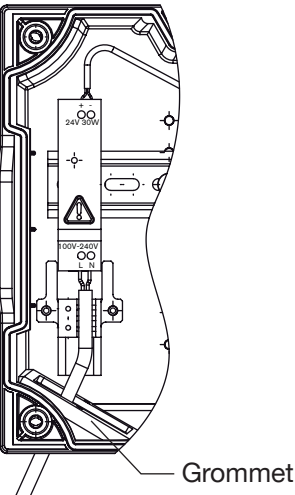
	<p>Step 1: Remove the internal protective cover of the switched-mode power supply</p> <ul style="list-style-type: none"> → Open the cover of the electronic-modules housing (see chapter 7.3). → With a regular screwdriver (5.5 mm slotted tip), loosen the 2 locking screws counterclockwise, until the stop. → Remove the protective cover.
	<p>Step 2: Remove the cable clamp.</p> <ul style="list-style-type: none"> → Loosen the 2 screws with an hex key 2.5 mm. → Remove the cable clamp.
	<p>Step 3: Connect the wires</p> <ul style="list-style-type: none"> → Strip 25 mm from the end of the cable. → Expose 8 mm of the wires. → Put the cable through the grommet. → Crimp the wire tips if the wires used are flexible. → Connect the wires with a regular screwdriver (2.5 mm tip). → Tighten the terminal block at the tightening torque of 0.5 Nm ± 20 %.

 <p>Cable clamp</p>	<p>Step 4: Secure the cable</p> <ul style="list-style-type: none"> → If necessary, adjust the length of the cable. → If you have removed the switched-mode power supply from the DIN rail, put it back in its initial position on the rail. → Put the cable clamp on the cable. → Tighten the cable clamp with an hex key, 2.5 mm, at a tightening torque of $0.5 \text{ Nm} \pm 20 \%$. <p>⚠ DANGER</p> <p>Risk of electrocution if the switched-mode power supply is not covered with the protective cover.</p> <ul style="list-style-type: none"> ▶ Before energizing the system, always put the protective cover on the switched-mode power supply
 <p>2 screws</p>	<p>Step 5: Put the protective cover on the switched-mode power supply</p> <ul style="list-style-type: none"> → Put the protective cover on the DIN rail. → With a regular screwdriver (5.5 mm tip), tighten the 2 screws clockwise at a tightening torque of $0.5 \text{ Nm} \pm 20 \%$.

Fig. 16: Connection of the VAC power supply to the system

7.6.4 Doing the electrical installation of a system with a V DC power supply

- Engage the electrical cable through the cable entry plate.
- Connect the VDC power supply according to Fig. 17, chapter [7.6.1 Terminal assignment of the terminal blocks](#), and chapter [7.6.2 Pin assignment of the M12 connectors](#).

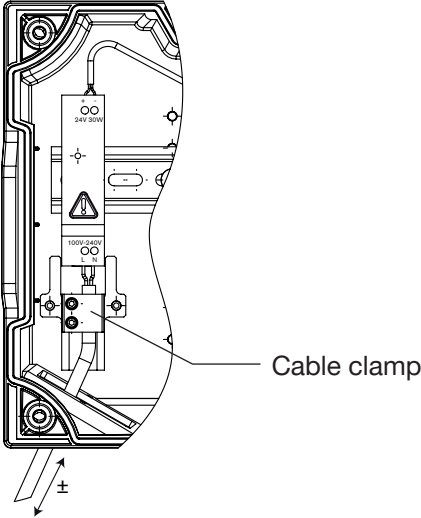
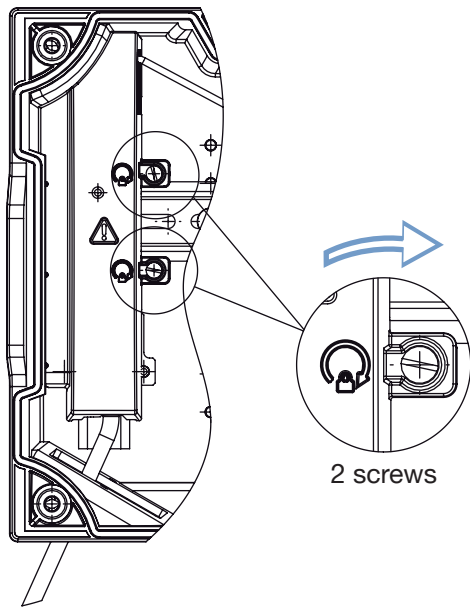
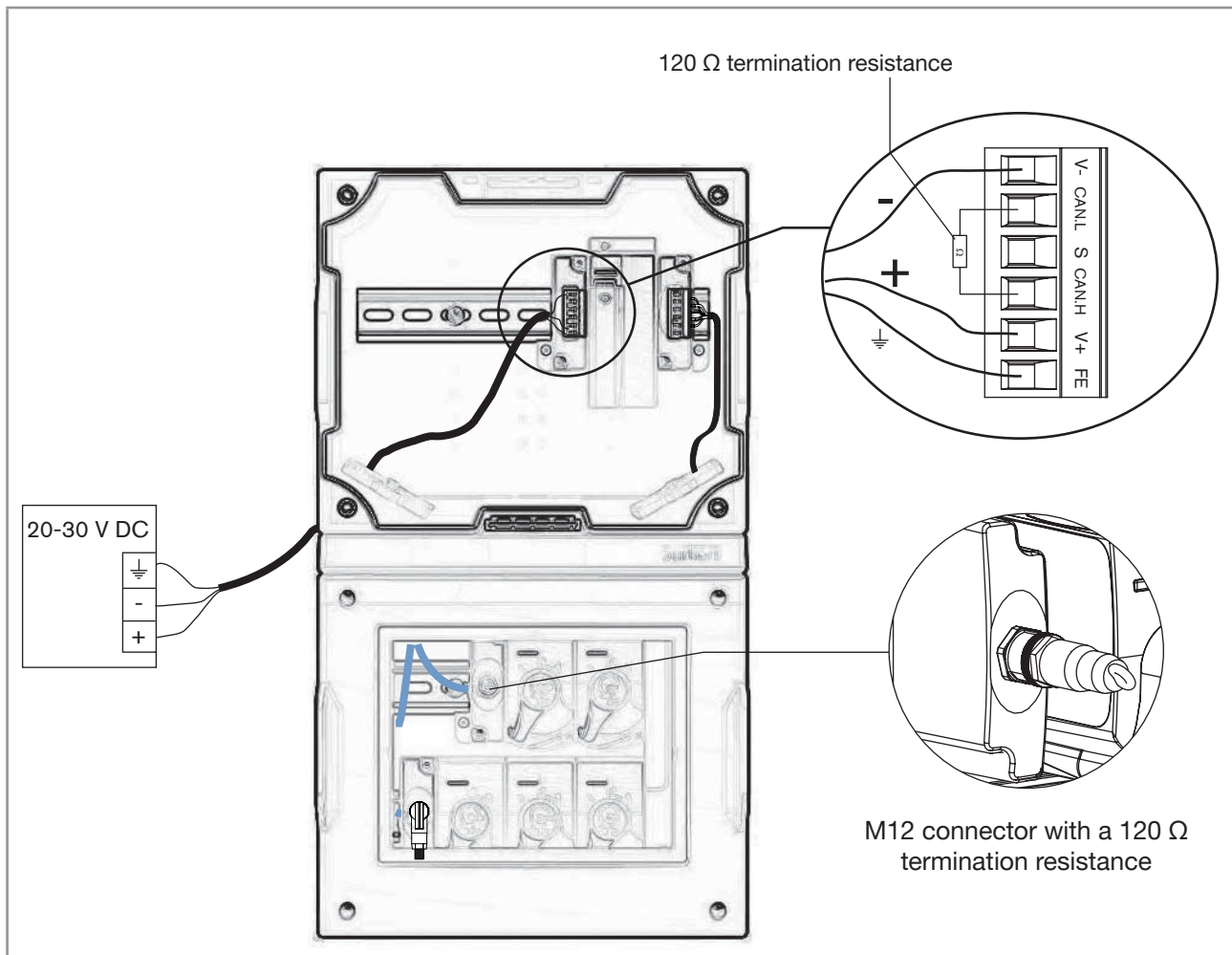

Fig. 17: Connecting the system to the VDC power supply

7.6.5 Connecting the system to a CANopen interface

The system can be connected to a CANopen interface (e.g. the Bürkert Communicator communication software):

- via one of the M12 connectors, male or female. Do not power the system via the female M12 connector.
 - or via one of the terminal blocks in the box containing the electronic modules. Do not power the system via the power feed terminal block.
- Connect the system according to the instructions in chapters [7.6.1 Terminal assignment of the terminal blocks](#) and [7.6.2 Pin assignment of the M12 connectors](#).
 - For the termination resistances installed in the factory, follow the recommendations for the CANopen bus.

7.7 Removing a sensor cube from the backplane

! To avoid water hammers in the system and before removing the last sensor cube from its backplane, stop the circulation of the water.

To remove a sensor cube from its backplane, do the following.

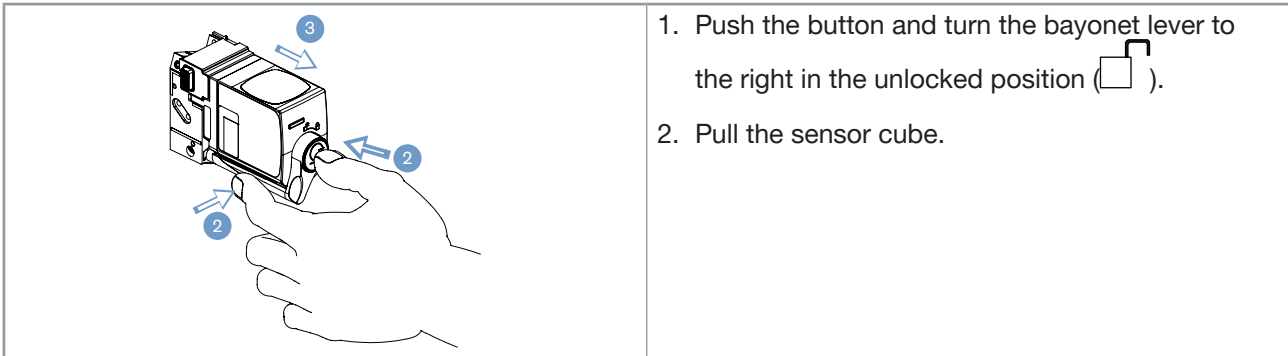

Fig. 18: Removing the sensor cube from the backplane

7.8 Closing a housing

The closing of the 2 housings is made in the same way.



DANGER

Risk of electrocution if the electronic-modules housing is open, because its IP65 protection is not ensured.

► Close the housing after any work with respect to the closing instructions of the housing.

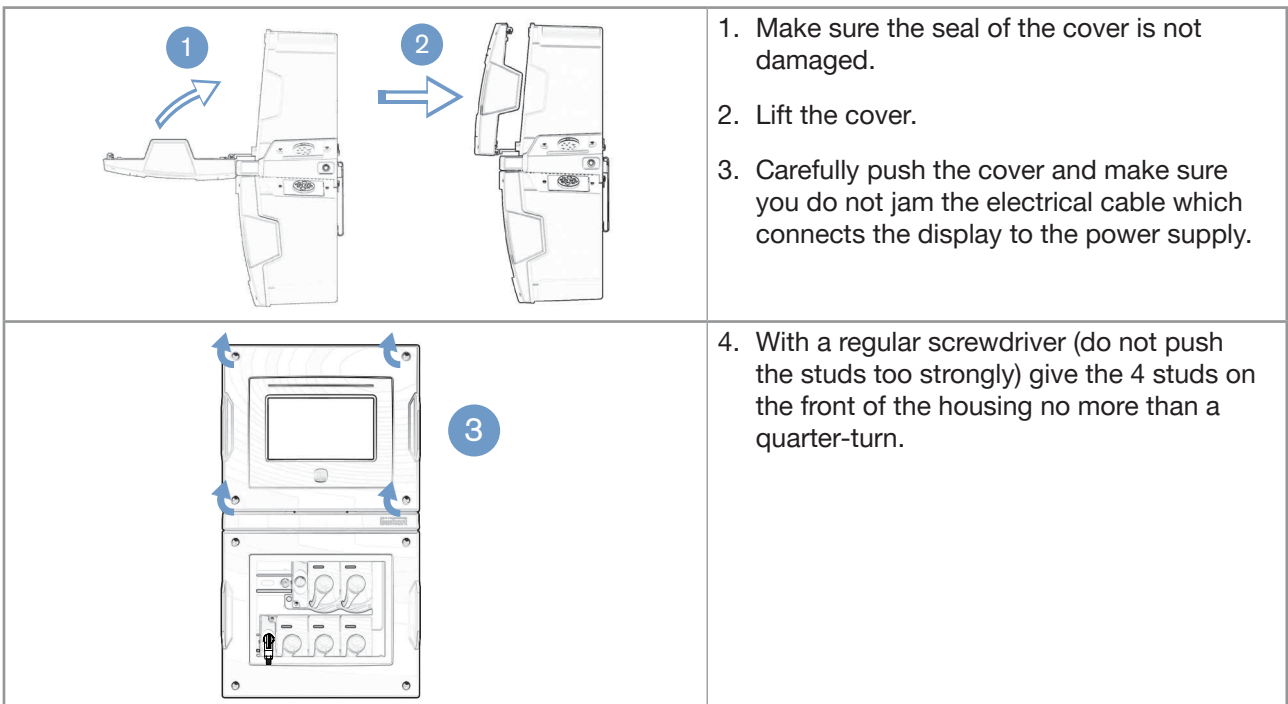

Fig. 19: Closing a housing

8 ADJUSTMENT, OPERATION

8.1 Safety instructions



WARNING

Risk of injury

Non-conforming adjustment, commissioning or use could lead to injuries and damage the system and its surroundings.

- ▶ The operators in charge of adjustment must have read and understood the contents of the Operating Instructions.
- ▶ In particular, observe the safety recommendations and intended use.
- ▶ The system/installation must only be operated by suitably trained staff.

8.2 Before commissioning the system

Before commissioning the system:

- make sure that at least one sensor cube is inserted on a backplane.
 - make sure the system is tight.
- To adjust the display and the views, refer to the Operating Instructions of the display software type ME21, available on the CD.
- To adjust a given electronic module, refer to the related Operating Instructions available on the CD.
- To adjust a given sensor cube, refer to the related Operating Instructions available on the CD.

9 MAINTENANCE AND TROUBLESHOOTING

9.1 Safety instructions



DANGER

Danger due to electrical voltage.

- ▶ Shut down the electrical power source of all the conductors and isolate it before carrying out work on the system.
- ▶ Observe all applicable accident protection and safety regulations for electrical equipment.

Risk of injury due to high pressure in the installation.

- ▶ Stop the circulation of fluid, cut off the pressure and drain the pipe before loosening the process connections.



WARNING

Risk of injury due to non-conforming maintenance.

- ▶ Maintenance must only be carried out by qualified and skilled staff with the appropriate tools.
- ▶ Obey the maintenance instructions of these Operating Instructions and the maintenance instructions of the Operating Instructions of all the electronic modules and of all the sensor cubes that are fitted in the system.

9.2 Cleaning of the system

Only the external parts of the system and the internal parts of the sensor-cubes housing can be cleaned with a cloth dampened with water or a detergent compatible with the materials the system is made of.

Please feel free to contact your Bürkert supplier for any additional information.

9.3 Maintenance on a component

To do maintenance on an electronic module or on a sensor cube, refer to the related Operating Instructions available on the CD delivered with the system.

9.4 Troubleshooting

Problem	What to do
The system status light and the display are OFF	→ Make sure the system is energized.
The water does not flow	→ Make sure the fluidic installation is correct.
Incorrect values are measured	→ Make sure the flow rate in the system is between 3 l/h and 6 l/h.
The LEDs of the sensor cubes are OFF	→ Make sure the electrical connections in the system housings are correct. → Make sure the electrical connection between the 2 system housings is correct.
There is water in the bottom of the sensor-cubes housing.	→ Make sure all the sensor cubes are correctly mounted on the backplanes and locked. → Make sure the quick-connect couplings of the water pipes are tight and correctly mounted.

10 SPARE PARTS AND ACCESSORIES



CAUTION

Risk of injury and/or damage caused by the use of unsuitable parts.

Incorrect accessories and unsuitable replacement parts may cause injuries and damage the system and the surrounding area.

- ▶ Use only original accessories and original replacement parts from Bürkert.
- ▶ Only do the maintenance procedures that are given in these Operating Instructions or in the Operating Instructions of the electronic modules or those of the sensor cubes.

Accessory	Order code
Set with: <ul style="list-style-type: none"> • a pressure reducer (including a 100 µm strainer, a sampling point and 2 G1/4" connections). • a wall bracket with nut, for the pressure reducer. • a pressure gauge for the pressure reducer. • 2 quick-connect couplings. 	566319
Set with the wall bracket and 4 self-adhesive bumpers	566363
Male M12 connector with a 120 Ω termination resistance	772424

11 PACKAGING, TRANSPORT

NOTE

Damage due to transport

Transport may damage an insufficiently protected system.

- ▶ Plug out all the electronic modules and all the sensor cubes from the system.
- ▶ Protect the electrical interfaces using protective plugs.
- ▶ Transport each electronic module and each sensor cube separately in a shock-resistant packaging and away from humidity and dirt.
- ▶ Transport the system in a shock-resistant packaging and away from humidity and dirt.
- ▶ Do not expose the system to temperatures that may exceed the admissible storage temperature range.
- ▶ Do not expose the electronic modules and the sensor cubes to temperatures that may exceed the admissible storage temperature range.
- ▶ Keep the packaging of the system and the shock absorbent paper because they must be used to send the system back to the after-sales service.

12 STORAGE

NOTE

Poor storage can damage the system.

→ To store the system for less than 4 days:

- ▶ rinse the complete hydraulic circuit with tap water, cut-off the power supply, and purge the system with air at the maximum pressure of 2 bar.
- ▶ store at room temperature (about 23 °C), the system with the sensor cubes plugged on their backplanes.
- ▶ store the system in a dry place away from dust.

→ To store the system for more than 4 days:

- ▶ rinse the complete hydraulic circuit with tap water, cut-off the power supply, and purge the system with air at the maximum pressure of 2 bar.
- ▶ remove each sensor cube from its backplane.
- ▶ refer to the Operating Instructions of each sensor cube for the related storage conditions.
- ▶ store the system without sensor cubes at a temperature between -20 °C and +70 °C.

13 DISPOSAL

Environmentally friendly disposal



- ▶ Follow national regulations regarding disposal and the environment.
- ▶ Collect electrical and electronic devices separately and dispose of them as special waste.

Further information at country.burkert.com.

