

Type 8756

Mass flow controller (MFC)/mass flow meter (MFM) for liquids

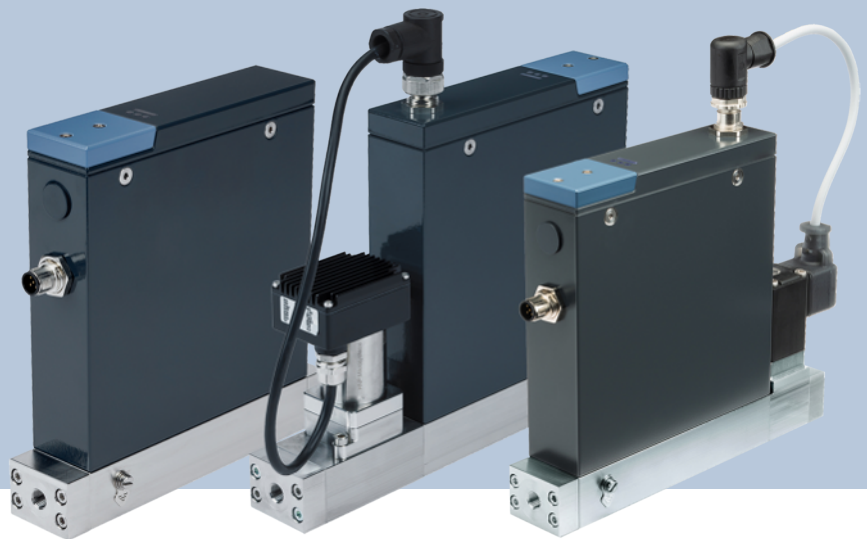

Operating Instructions

We reserve the right to make technical changes without notice.

© Bürkert SAS 2020-2026

Technical documentation 2604/08_GBen_318136203_99079192120357643 / Original EN

Table of contents

1	About this document	6
1.1	Symbols	6
1.2	Terms and abbreviations	7
1.3	Manufacturer	7
2	Safety	8
2.1	Intended use	8
2.2	Safety instructions	8
3	Product description	11
3.1	Product overview	11
3.2	Product identification	17
3.2.1	Type label	17
3.2.2	Calibration label	17
3.2.3	Conformity marking	17
3.2.4	Symbols and markings on device	18
3.3	Display elements	18
3.3.1	Status indicator	18
3.3.2	NAMUR mode	19
3.3.3	Network status indicator	19
3.3.4	Communication indicator	20
3.4	Functionality	20
3.4.1	Service-büS interface	20
3.4.2	Pump	20
3.4.3	Control valve	21
3.4.4	Customised actuator	21
3.4.5	Memory card	22
4	Technical data	23
4.1	Standards and directives	23
4.2	Operating conditions	23
4.3	Medium data	25
4.3.1	Calibration conditions	25
4.3.2	Operating medium	26
4.3.3	Density measurement	27
4.3.4	Temperature measurement	28
4.3.5	Mass flow rate measurement	29
4.3.6	Pressure loss	33
4.4	Electrical data	36
4.5	Communication	44
4.5.1	Industrial Ethernet: EtherCAT	44
4.5.2	Industrial Ethernet: EtherNet/IP	44
4.5.3	Industrial Ethernet: Modbus TCP	45
4.5.4	Industrial Ethernet: PROFINET IO	45
4.6	Mechanical data	45
5	Medium connection	46
5.1	Possible medium connections	46
5.2	Installation procedure	46
5.2.1	G1/8"-internal-threaded connections	51

5.2.2	NPT1/8"-internal-threaded connections	51
5.2.3	Connections with external-threaded vacuum fittings	51
5.2.4	Connections with external-threaded compression fittings	51
5.2.5	Tri-clamp connections	52
6	Electrical connection	53
6.1	Additional documentation	53
6.2	Wire the variant bÜS /CANopen	53
6.2.1	With bÜS extension cables from Bürkert	53
6.2.2	With bÜS cables from Bürkert	53
6.2.3	With CANopen cables	54
6.3	Wire the variant Analogue	56
6.3.1	Digital input	58
6.3.2	Relay output	59
6.4	Wire the variant Industrial Ethernet	61
6.5	Change the network parameters	62
6.5.1	Over the product web server	62
6.5.2	Over the Bürkert Communicator software	63
6.6	Connect the functional earth	63
6.7	Connect the external actuator	64
6.7.1	Connection examples with Bürkert valves	64
7	Commissioning	65
7.1	Commissioning procedure	65
7.2	Fill the pipe without damaging the pump	66
8	Configuration with Bürkert Communicator	67
8.1	Setting tools	67
8.2	Connect to the Bürkert Communicator	67
8.3	User levels in the Bürkert Communicator	69
8.3.1	Enabling password protection	69
8.3.2	Activating or deactivating user level	70
8.4	Functions	70
8.4.1	Empty-pipe detection	70
8.4.2	Bubble detection	70
8.4.3	Cut-off	71
8.4.4	Flush bubbles from the pipe	72
8.4.5	Configure the actuator	73
8.5	Set the CANopen communication or the bÜS communication	73
8.6	Increase the data transmission speed	73
8.7	Operation modes	74
8.8	Normal operation mode	74
8.8.1	Analogue variant	76
8.8.2	Industrial Ethernet variant	77
8.8.3	bÜS /CANopen variant	77
8.9	Optimise the closed-loop control parameters	77
8.10	Select the source that gives the set-point value	78
8.11	Set-point values without communication	79
8.12	Automatic flushing	80
8.13	Changing between bÜS and CANopen mode	80
9	Maintenance	81

9.1	Replace the memory card	81
9.2	Sterilising the device with hot water	82
9.3	Sterilising the device with steam	82
10	Troubleshooting	83
10.1	Status indicator is red	83
10.2	Status indicator is orange	84
10.3	Status indicator is yellow	84
10.4	Status indicator is blue	85
10.5	Status indicator is off	86
10.6	Status indicator flashes	86
10.7	Status indicator goes out periodically	86
10.8	Replacement device adopts none of the values from the defective device	86
10.9	Replacement device does not adopt all of the values from the defective device	87
10.10	No mass flow rate	87
10.11	Unstable measured value	87
10.12	Set-point value at 0 %, but medium still flows	88
10.13	Set-point value at 0 %, no mass flow, but a non-zero mass flow rate is measured	89
10.14	Set-point value is not reached	89
10.15	Outgassing or bubble formation at the device outlet	90
10.16	Network status indicator	91
11	Uninstallation	92
11.1	Dismantling	92
12	Spare parts and accessories	93
12.1	Electrical accessories	93
12.2	Mounting accessories	94
12.3	Additional software	94
13	Logistics	95
13.1	Transport and storage	95
13.2	Return	95
13.3	Disposal	95

1 About this document

The document is an important part of the product and guides the user to safe installation and operation. The information and instructions in this document are binding for the use of the product.

- ▶ Before using the product for the first time, read and observe the whole safety chapter.
- ▶ Before starting any work on the product, read and observe the respective sections of the document.
- ▶ Keep the document available for reference and give it to the next user.
- ▶ Contact the Bürkert sales office for any questions.



Further information concerning the product at [Products](#).

- ▶ Enter the article number from the type label in the search bar.

The illustrations in these instructions may vary depending on the product variant.

1.1 Symbols



DANGER!

Warns of a danger that leads to death or serious injuries.



WARNING!

Warns of a danger that can lead to death or serious injuries.



CAUTION!

Warns of a danger that can lead to minor injuries.

NOTICE!

Warns of property damage on the product or the installation.



Indicates important additional information, tips and recommendations.



Refers to information in this document or in other documents.

- ▶ Indicates a step to be carried out.

✓ Indicates a result.

Menu Indicates a software user-interface text.

1.2 Terms and abbreviations

The terms and abbreviations are used in this document to refer to following definitions.

Device	Type 8756
MFM	Mass flow meter
MFC	Mass flow controller
büS	Bürkert system bus, a communication bus developed by Bürkert and based on the CANopen protocol
bar, bar (g)	Unit for relative pressure
bar abs	Unit for absolute pressure
Ex area	Potentially explosive atmosphere
Ex approval	Approval for potentially explosive atmosphere

1.3 Manufacturer

Bürkert SAS

20, rue du Giessen

67220 TRIEMBACH-AU VAL

FRANCE

The contact addresses are available at [Contact](#).



Need more information or additional products?

► Explore the full range of products on our [eShop](#).

2 Safety

2.1 Intended use

The device MFM is designed to measure the mass flow rate of liquids.

The device MFC is designed to measure and regulate the mass flow rate of liquids.

The permitted media are listed in [Technical data \[▶ 23\]](#).

Prerequisites for safe and trouble-free operation are proper transport, storage, installation, commissioning, operation and maintenance.

The instructions are part of the device. The device is intended exclusively for use within the scope of these instructions. Uses of the device that are not described in these instructions, the contractual documents or the type label can lead to severe personal injury or death, damage to the device or property and dangers for the surrounding area or the environment.

- ▶ Only trained and qualified personnel may install, operate and maintain the device. See qualification of persons in [Safety instructions \[▶ 8\]](#)
- ▶ Use the device only in conjunction with third-party devices and components recommended and authorized by Bürkert.
- ▶ Use the device only when it is in perfect condition.
- ▶ Only use the device indoors.
- ▶ Only use devices that are approved for this type of potentially explosive atmosphere. These devices are labelled with the ATEX label on the type label. When using, always observe the details on the type label and the instructions for the potentially explosive atmosphere included in the scope of delivery for the device.
- ▶ Do not open the device.
- ▶ Do not use the device in high-vibration areas.

2.2 Safety instructions

Qualification of personnel working with the device

Improper use of the device can lead to serious personal injury or death. To avoid accidents when working with the device, the following minimum requirements must be met:

- ▶ Carry out work on the device within the scope of these instructions in a safety-compliant manner.
- ▶ Detect and avoid dangers when working on the device.
- ▶ Understand the instructions and implement the information contained therein accordingly.

Responsibility of the operator

The operator is responsible for observing the location-specific safety regulations, also in relation to personnel.

- ▶ Observe the general rules of technology.
- ▶ Install the device according to the regulations applicable in the respective country.
- ▶ The operator must make hazards arising from the location of the device avoidable by providing appropriate operating instructions.

Electrostatically sensitive components and assemblies

The device contains electronic components that are susceptible to the effects of electrostatic discharging (ESD). Components that come into contact with electrostatically charged persons or objects are at risk. In the worst case scenario, these components will be destroyed immediately or fail after start-up.

- ▶ Meet the requirements specified by EN 61340-5-1 to minimise or avoid the possibility of damage caused by a sudden electrostatic discharge.
- ▶ Do not touch electronic components when the supply voltage is connected.

Electric shock due to electrical components

Touching live parts can result in severe electric shock. This can lead to serious personal injury or death.

- ▶ Before working on the device or system, switch off the power supply. Secure it against reactivation.
- ▶ Observe any applicable accident prevention and safety regulations for electrical devices.

Changes and other modifications, spare parts and accessories

Changes to the device, incorrect installation or use of non-approved devices or components create hazards that can lead to accidents and injuries.

- ▶ Do not make any changes to the device.
- ▶ Do not mechanically load the device.
- ▶ Observe the operating instructions of the device or component used.
- ▶ Only use the devices in conjunction with devices and components recommended or approved by Bürkert.

Spare parts and accessories that do not meet Bürkert's requirements may impair the operational safety of the device and cause accidents.

- ▶ To ensure operational safety, only use original parts from Bürkert.

Operation only after proper transport, storage, installation, commissioning, or maintenance

Improper transport, storage, installation, commissioning, or maintenance jeopardises the operational safety of the device and can cause accidents. This can lead to serious personal injury or death.

- ▶ Observe all values and limits specified in these instructions to ensure the device's safety and functionality.
- ▶ Only carry out work described in these instructions.
- ▶ Only carry out work using suitable tools.
- ▶ All other work must be carried out by Bürkert only.

Working on the device

Working on the device that has not been powered down, unauthorised switching on or uncontrolled start-up of the system can cause accidents. This can lead to serious personal injury or death.

- ▶ Only work on the device when it is not in use.
- ▶ Ensure that the device or system cannot be switched on unintentionally.

- ▶ Only start the process in a controlled manner following disruptions. Observe sequence:
 1. Apply supply voltage or pneumatic supply.
 2. Charge the device with medium.

Technical limit values and media

Non-compliance with technical limit values or unsuitable media can damage the device and lead to leaks. This can cause accidents and seriously injure or kill people.

- ▶ Comply with limit values. See **Technical data [▶ 23]** and information on the type label.
- ▶ Only feed media into the media ports that are listed in the chapter **Technical data [▶ 23]**.
- ▶ Observe the safety data sheet for the media used.

Only use authorised devices in potentially explosive atmospheres

Devices that may be used in potentially explosive atmospheres are labelled with an Ex marking. Additional instructions with Ex labelling are included with these devices.

- ▶ Only use devices that are approved for use in a potentially explosive atmosphere.
- ▶ For use in potentially explosive atmospheres, observe the information on the device.
- ▶ For use in potentially explosive atmospheres, observe the additional instructions with Ex labelling.
- ▶ Do not use devices that do not have this Ex labelling and additional instructions in potentially explosive atmospheres under any circumstances.

Medium under pressure

Medium under pressure can seriously injure people. In the event of overpressure or pressure surges, the device or lines can burst. Pneumatic lines that are defective or not securely fastened can come loose and swing around.

- ▶ Before working on the device or system, switch off the pressure. Vent or empty the lines.
- ▶ Adhere to the permitted pressure ranges of the medium.
- ▶ Comply with the permitted temperature ranges of the medium.

Hot surfaces and fire hazard

The surface of the device can become hot with fast-switching actuators or with hot media.

- ▶ Wear suitable protective gloves.
- ▶ Keep highly flammable substances and media away from the device.

3 Product description

3.1 Product overview

MFM Analogue | MFC Analogue for modular actuator

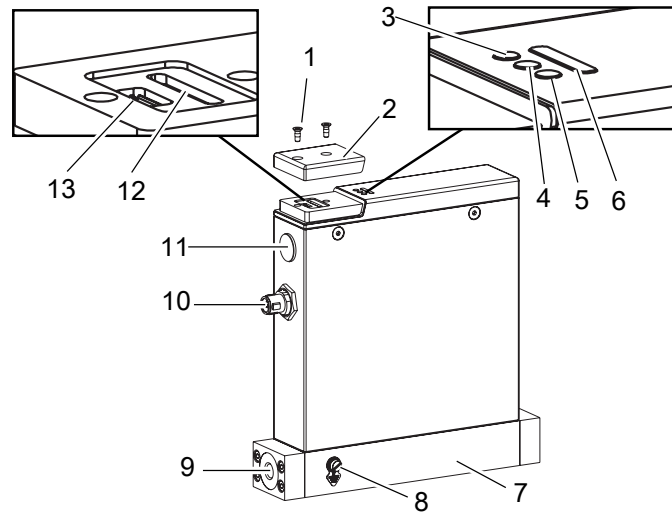

Fig. 1: Example of a variant

1 Screw	2 Cover
3 Not used	4 Not used
5 Not used	6 Status indicator
7 Base block	8 Functional earth connection
9 Medium connection	10 Electrical connection
11 Electrical connection - M12	12 Slot for memory card
13 bÜS interface	

MFM büS/CANopen | MFC büS/CANopen for modular actuator

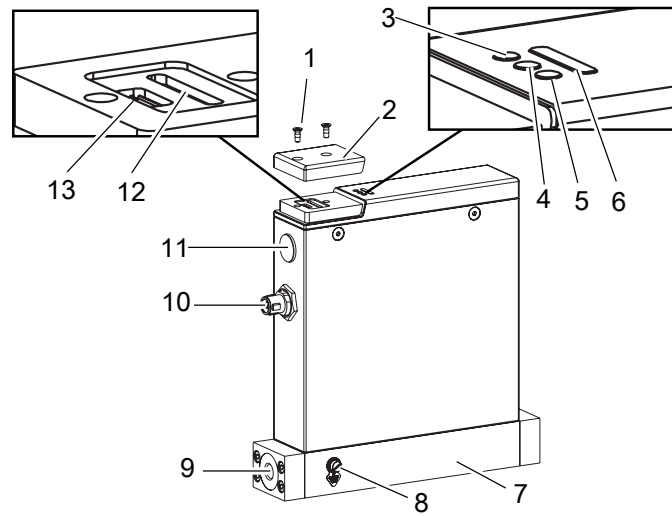

Fig. 2: Example of a variant

1 Screw	2 Cover
3 Not used	4 Not used
5 Not used	6 Status indicator
7 Base block	8 Functional earth connection
9 Medium connection	10 Electrical connection
11 Not used	12 Slot for memory card
13 büS interface	

MFM Industrial Ethernet | MFC Industrial Ethernet for modular actuator

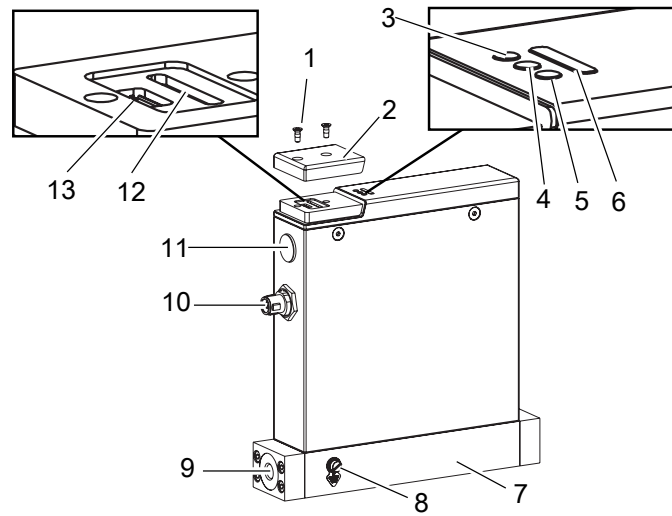

Fig. 3: Example of a variant

1 Screw	2 Cover
3 Status indicator - ETH port 1	4 Communication indicator
5 Status indicator - ETH port 2	6 Status indicator
7 Base block	8 Functional earth connection
9 Medium connection	10 Electrical connection
11 Electrical connection - 2 x M8	12 Slot for memory card
13 bus interface	

MFC Analogue with proportional valve | MFC Analogue with pump

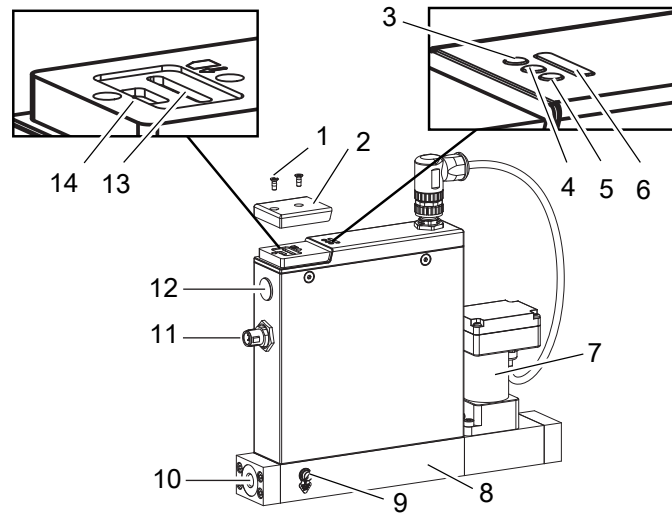

Fig. 4: Example of a variant

1 Screw	2 Cover
3 Not used	4 Not used
5 Not used	6 Status indicator
7 Actuator	8 Base block
9 Functional earth connection	10 Medium connection
11 Electrical connection	12 Electrical connection - M12
13 Slot for memory card	14 bus interface

MFC büS/CANopen with proportional valve | MFC büS/CANopen with pump

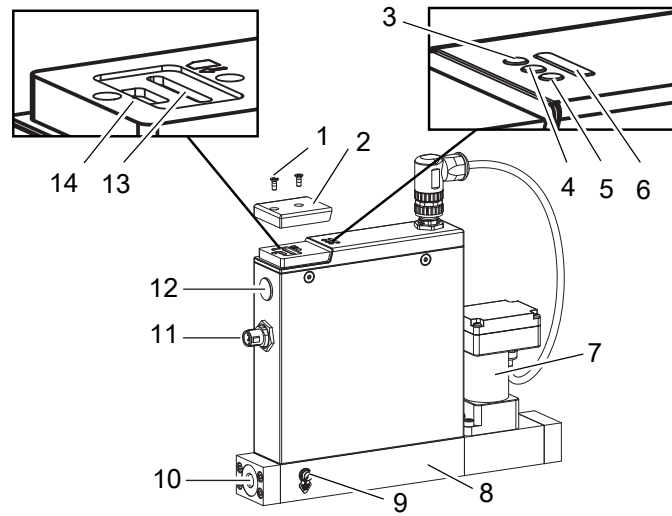

Fig. 5: Example of a variant

1 Screw	2 Cover
3 Not used	4 Not used
5 Not used	6 Status indicator
7 Actuator	8 Base block
9 Functional earth connection	10 Medium connection
11 Electrical connection	12 Not used
13 Slot for memory card	14 büS interface

MFC Industrial Ethernet with proportional valve | MFC Industrial Ethernet with pump

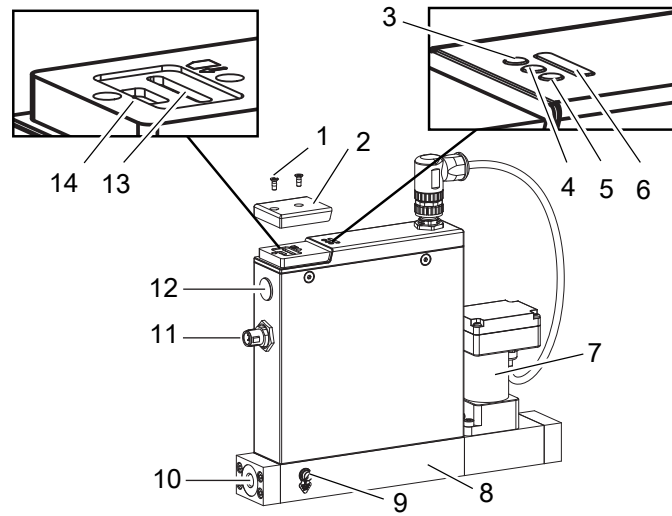

Fig. 6: Example of a variant

1 Screw	2 Cover
3 Status indicator - ETH port 1	4 Communication indicator
5 Status indicator - ETH port 2	6 Status indicator
7 Actuator	8 Base block
9 Functional earth connection	10 Medium connection
11 Electrical connection	12 Electrical connection - 2 x M8
13 Slot for memory card	14 büS interface

3.2 Product identification

3.2.1 Type label

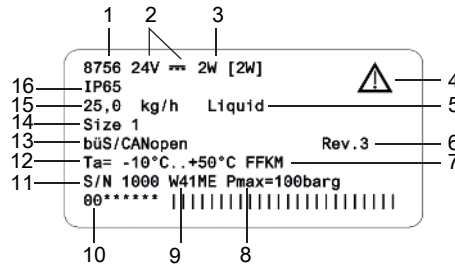

Fig. 7: Example of type label Type 8756

1 Type	2 Operating voltage
3 Power consumption	4 Note: Observe the operating instructions
5 Calibration medium	6 Bürkert internal version
7 Sealing material	8 Maximum operating pressure
9 Manufacture code	10 Article number
11 Serial number	12 Ambient temperature
13 Protocol	14 Size of the sensor
15 Nominal mass flow rate (Q nominal)	16 Degree of protection

3.2.2 Calibration label

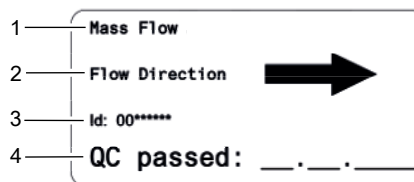

Fig. 8: Example of calibration label

1 Variant	2 Flow direction
3 Article number	4 Manufacturing date

3.2.3 Conformity marking

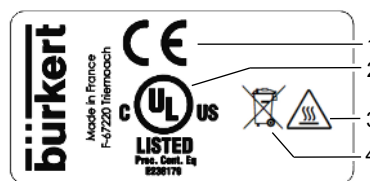

Fig. 9: Conformity label

1 CE marking	2 Certification marking for USA and/or Canada
3 Warning: hot surface	4 Indication for disposal

3.2.4 Symbols and markings on device



Earth terminal



Direct current

Industrial Ethernet variant

DC-B0-58-FF-FF-
FF

Example of marking of the MAC address

ETH1, ETH2

Ethernet connections

3.3 Display elements

3.3.1 Status indicator

The status indicator changes its colour based on the NAMUR recommendation NE 107. Refer to [NAMUR mode \[► 19\]](#).

The colour of the status indicator indicates:

- Whether device diagnostics are active or not. Diagnostics are active on the device and cannot be deactivated.
- If diagnostics are active, then the status indicator shows whether diagnostics events have been generated or not. If several diagnostics events have been generated, then the status indicator shows the diagnostics event with the highest priority.

If the status indicator flashes, then the device is selected in a man-machine interface such as the Bürkert Communicator software.

- ▶ To solve a problem indicated by the status indicator, refer to [Troubleshooting \[► 83\]](#)

3.3.2 NAMUR mode

The status indicator shows the status of the device and its peripherals, based on NAMUR recommendation 107 (NE 107).

If various alerts are present, the status indicator always shines in the colour of the highest prioritised alert (red = outage = highest priority).

Colour	Colour code	Status signal	Description
Red	5	Failure	Due to a malfunction in the device or its periphery, normal operation is not possible.
Orange	4	Check function	Work is being carried out on the device, which means that normal operation is temporarily not possible.
Yellow	3	Out of specification	The environmental or process conditions for the device are outside the specified range. Internal device diagnosis indicate problems in the device or process characteristics.
blue	2	Maintenance required	The device is in normal operation, although a function is briefly restricted. ▶ Service device
Green	1	Diagnosis active	Device is running faultlessly, diagnosis are active.
White	0	Diagnosis passive	Device is switched on, diagnosis are inactive.

Tab. 1: Status indicator according to NE 107

3.3.3 Network status indicator

Industrial Ethernet variant

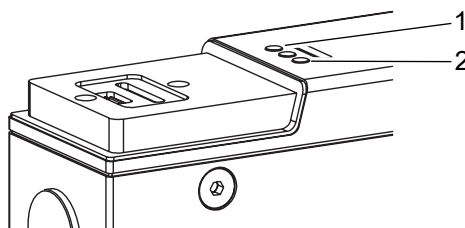

Fig. 10: Location and description of the LED's

1 Ethernet Port 1

2 Ethernet Port 2

3.3.4 Communication indicator

Industrial Ethernet variant

This LED shows the status of the communication between the device and the PLC (Programmable Logical Controller).

LED indicator	Description	Meaning
Green	RUN	Connection to the PLC is active.
Red	ERROR	Connection to the PLC is inactive.

Tab. 2: Description of the communication indicator

3.4 Functionality

3.4.1 Service-büs interface

Analogue variant | Industrial Ethernet variant

The Service-büs interface is used for short-term servicing of the device with the Bürkert Communicator.

The Bürkert Communicator runs under Windows. Refer to [Connect to the Bürkert Communicator \[▶ 67\]](#)

The USB-büs-Interface set, available as an accessory, is necessary. Refer to [Spare parts and accessories \[▶ 93\]](#)

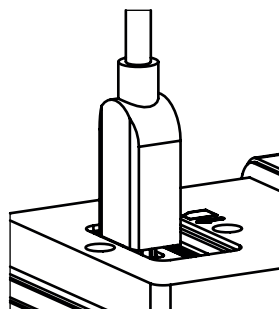

Fig. 11: büS stick, inserted in the related connector of the device

3.4.2 Pump

MFC with pump

The pump is a micro-annular gear pump.

NOTICE!

The micro-annular gear pump is not completely tight.

- ▶ To avoid possible problems that are due to leakage, make sure that no medium flows when the pump is switched off. Take into account the static pressure.

NOTICE!

Risk of damage to the pump due to the suction pressure.

- ▶ The suction pressure must be as low as possible and always lower than 200 mbar.

The service life of the pump is approximately 8,000...10,000 hours. The value depends on the following criteria:

- the dry cycle time of the pump
- the pump speed
- the medium used
- the back pressure

3.4.3 Control valve

MFC with proportional valve

The control valve is a direct-acting and normally-closed proportional valve.

The control valve provides the sealing function when the following conditions are met:

- The device is used within the specified pressure range.
- The device is equipped with a valve seat seal that is made of a soft material such as FKM, FFKM or EPDM.



If the valve seat seal is made of a hard material such as PCTFE, then the control valve may not be tight.

Valves with a seat size of 0.05 mm or 0.1 mm have a seat seal made of a hard material.

Unstable measured values may occur. Refer to [Unstable measured value \[▶ 87\]](#)

3.4.4 Customised actuator

MFC for modular actuator

The device can be combined to the following actuators:

- a proportional valve
- a pump

When selecting the actuator, observe the following basic data of the device:

- nominal flow rate
- inlet pressure

Refer to [Configure the actuator \[▶ 73\]](#).

3.4.5 Memory card



If the memory card is defective or has been lost, contact the Bürkert sales office to purchase a new one.

The device can be delivered with a memory card that is inserted in the device. When the device is energised, there are two possibilities:

- If the inserted memory card contains device-specific data, the device automatically adopts this data. At the time of delivery, the memory card is preloaded with device-specific information. To view the stored data, refer to the file Device Description File.
- If the inserted memory card is empty, the device saves its own data onto the card. A new memory card is empty.

To download the file Device Description File:

- ▶ Access the page [Type 8756](#)
- ▶ Scroll down to **Downloads** > **Software**

The data stored on the memory card can be transferred to another device with the same article number. For example, data from a defective device can be transferred to a replacement device.

büS / CANopen variant

The büS/CANopen variant supports the config-client if no memory card is used.

- ▶ Activate this functionality in the Bürkert communicator under **General settings** > **Parameter** > **Act as a configuration client** > **Yes**.

For detailed information, refer to the "Software manual | Central configuration management".

- ▶ Access the page [Type 8756](#)
- ▶ Scroll down to **Downloads** > **User Manuals**

4 Technical data

4.1 Standards and directives

This product complies with the legal requirements applicable at the time of placing on the market and has been developed and tested in accordance with the relevant European directives/regulations and harmonized standards. The conformity is documented and, if necessary, supported by evidence. The EU Declaration of Conformity can be found behind the respective type on the home page country.burkert.com

4.2 Operating conditions

MFM

Ambient temperature	-10...+70 °C
Storage temperature	-10...+70 °C
Degree of protection (EN 60529 / IEC 60529)	IP65 ¹⁾
Altitude	Up to 2000 m above sea level
Medium temperature	-10...+70 °C, only in liquid state
Medium	Clean and homogeneous liquids
Operating pressure	G-internal-threaded FFKM or PCTFE: max. 100 bar (g) Metal: max. 50 bar (g)
Operating pressure	NPT-internal-threaded FFKM or PCTFE: max. 100 bar (g) Metal: max. 50 bar (g)
Operating pressure	External-threaded vacuum fittings max. 50 bar (g)
Operating pressure	External-threaded compression fittings max. 50 bar (g)
Operating pressure	Tri-Clamp max. 25 bar (g)
Relative ambient humidity	Max. 95% at 55 °C (non-condensing)

¹⁾ When cables or plugs and sockets are connected correctly, verified by Bürkert, not evaluated by UL.

MFC with pump

Ambient temperature	-10...+60 °C
Storage temperature	-10...+70 °C
Degree of protection (EN 60529 / IEC 60529)	IP40 ¹⁾
Altitude	Up to 2000 m above sea level
Medium temperature	-10...+60 °C, only in liquid state
Medium	Clean and homogeneous liquids
Operating pressure (inlet pressure)	0 barg
Operating pressure (outlet pressure)	max. 10 barg
Relative ambient humidity	Max. 95% at 55 °C (non-condensing)

MFC with proportional valve

Ambient temperature	-10...+50 °C
Storage temperature	-10...+70 °C
Degree of protection (EN 60529 / IEC 60529)	IP65 ¹⁾
Altitude	Up to 2000 m above sea level
Medium temperature	-10...+60 °C, only in liquid state
Medium	Clean and homogeneous liquids
Operating pressure (inlet pressure)	max. 5 barg
Relative ambient humidity	Max. 95% at 55 °C (non-condensing)

MFC for modular actuator

Ambient temperature	-10...+70 °C
Storage temperature	-10...+70 °C
Degree of protection (EN 60529 / IEC 60529)	IP65 ¹⁾
Altitude	Up to 2000 m above sea level
Medium temperature	-10...+70 °C, only in liquid state
Medium	Clean and homogeneous liquids
Operating pressure	G-internal-threaded FFKM or PCTFE: max. 100 bar (g) Metal: max. 50 bar (g)
Operating pressure	NPT-internal-threaded FFKM or PCTFE: max. 100 bar (g) Metal: max. 50 bar (g)
Operating pressure	External-threaded vacuum fittings max. 50 bar (g)
Operating pressure	External-threaded compression fittings max. 50 bar (g)
Operating pressure	Tri-Clamp max. 25 bar (g)
Relative ambient humidity	Max. 95% at 55 °C (non-condensing)

4.3 Medium data

4.3.1 Calibration conditions

MFM

Calibration medium	Water
Temperature of the calibration medium	25 °C
Calibration pressure	4 bar

MFC with pump

Calibration medium	Water
Temperature of the calibration medium	25 °C
Calibration pressure	4 bar

MFC with proportional valve

Calibration medium	Water
Temperature of the calibration medium	25 °C
Calibration pressure	4 bar

MFC for modular actuator

Calibration medium	Water
Temperature of the calibration medium	25 °C
Calibration pressure	4 bar

4.3.2 Operating medium

MFM

Maximum particle size	10 µm
Minimum dynamic viscosity	0.3 mPa.s
Maximum dynamic viscosity	1500 mPa.s Take the pressure loss into account. Refer to chapter Pressure loss.

MFC with pump

Maximum particle size	10 µm
Minimum dynamic viscosity	0.3 mPa.s
Maximum dynamic viscosity	200 mPa.s, with reduced flow-rate range. If the flow rate is equal to 8 kg/h, then the medium viscosity must be max. 50 mPa.s. Take the pressure loss into account. Refer to chapter Pressure loss.

MFC with proportional valve

Maximum particle size	10 µm
Minimum dynamic viscosity	0.3 mPa.s
Maximum dynamic viscosity	40 mPa.s, with reduced flow-rate range. Take the pressure loss into account. Refer to chapter Pressure loss.
Maximum back pressure	50% of the inlet pressure

MFC for modular actuator

Maximum particle size	10 µm
Minimum dynamic viscosity	0.3 mPa.s
Maximum dynamic viscosity	1500 mPa.s
	Take the pressure loss into account. Refer to chapter Pressure loss.

4.3.3 Density measurement

MFM

Density range	0...5 kg/l
Measurement accuracy	DN1: ±0.005 kg/l (for mass flow rate values higher than 1.5 kg/h) DN2: ±0.005 kg/l (for mass flow rate values higher than 5.7 kg/h)
Repeatability	DN1: ±0.0025 kg/l (for mass flow rate values higher than 1.5 kg/h) DN2: ±0.0025 kg/l (for mass flow rate values higher than 5.7 kg/h)

MFC with pump

Density range	0...5 kg/l
Measurement accuracy	±0.005 kg/l (for mass flow rate values higher than 1.5 kg/h)
Repeatability	±0.0025 kg/l (for mass flow rate values higher than 1.5 kg/h)

MFC with proportional valve

Density range	0...5 kg/l
Measurement accuracy	±0.005 kg/l (for mass flow rate values higher than 1.5 kg/h)
Repeatability	±0.0025 kg/l (for mass flow rate values higher than 1.5 kg/h)

MFC for modular actuator

Density range	0...5 kg/l
Measurement accuracy	DN1: ±0.005 kg/l (for mass flow rate values higher than 1.5 kg/h) DN2: ±0.005 kg/l (for mass flow rate values higher than 5.7 kg/h)
Repeatability	DN1: ±0.0025 kg/l (for mass flow rate values higher than 1.5 kg/h) DN2: ±0.0025 kg/l (for mass flow rate values higher than 5.7 kg/h)

4.3.4 Temperature measurement

MFM

Temperature range	-10...70 °C
Measurement accuracy	DN1: ±1.0 K (for mass flow rate values higher than 1.5 kg/h) DN2: ±1.0 K (for mass flow rate values higher than 5.7 kg/h)
Repeatability	DN1: ±0.5 K (for mass flow rate values higher than 1.5 kg/h) DN2: ±0.5 K (for mass flow rate values higher than 5.7 kg/h)

MFC with pump

Temperature range	-10...60 °C
Measurement accuracy	±1.0 K (for mass flow rate values higher than 1.5 kg/h)
Repeatability	±0.5 K (for mass flow rate values higher than 1.5 kg/h)

MFC with proportional valve

Temperature range	-10...60 °C
Measurement accuracy	±1.0 K (for mass flow rate values higher than 1.5 kg/h)
Repeatability	±0.5 K (for mass flow rate values higher than 1.5 kg/h)

MFC for modular actuator

Temperature range	-10...70 °C
Measurement accuracy	DN1: ±1.0 K (for mass flow rate values higher than 1.5 kg/h) DN2: ±1.0 K (for mass flow rate values higher than 5.7 kg/h)
Repeatability	DN1: ±0.5 K (for mass flow rate values higher than 1.5 kg/h) DN2: ±0.5 K (for mass flow rate values higher than 5.7 kg/h)

4.3.5 Mass flow rate measurement

MFM

Maximum mass flow rate	DN1: 30 kg/h DN2: 150 kg/h
Nominal mass flow rate	DN1: factory setting 30 kg/h (minimum reducible to Q _{nom} = 1 kg/h) DN2: factory setting 150 kg/h (minimum reducible to Q _{nom} = 5 kg/h)
Minimum measurable mass flow rate	DN1: factory setting 0.05 kg/h (can be reduced to 0.01 kg/h) DN2: factory setting 0.25 kg/h (can be reduced to 0.05 kg/h)
Measurement accuracy after 1 minute warm-up time	DN1: ±0.1% of the measured value or ±1.4 g/h. 1.4 g/h = zero-point stability ²⁾ DN2: ±0.1% of the measured value or ±10 g/h. 10 g/h = zero-point stability ³⁾
Maximum measurement range	1:3000 The measurement range is defined as the ratio of Q _{nominal} of the device to Q _{min} . Refer to following figure. DN1: Q _{min} = 0.05 kg/h DN2: Q _{min} = 0.25 kg/h
Repeatability	DN1: ±0.05% of the measured value or ±0.7 g/h DN2: ±0.05% of the measured value or ±5 g/h
Response time (t _{95%})	< 750 ms The response time depends on the medium used

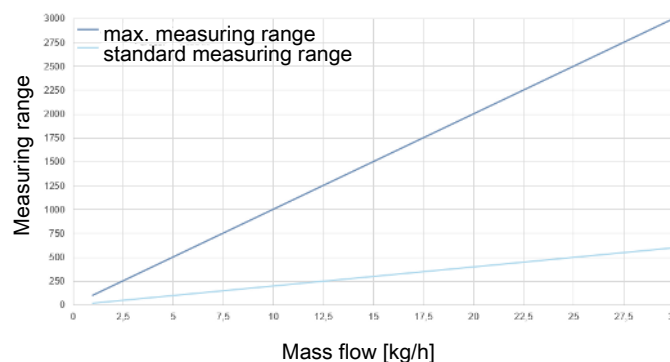

Fig. 12: Measurement range depending on nominal flow rate for DN1

²⁾ Zero point applies to water at calibration conditions; for flows of <1.4 kg/h and deviating medium, please consult Bürkert.

³⁾ Zero point applies to water at calibration conditions; for flows of <15 kg/h and deviating medium, please consult Bürkert.

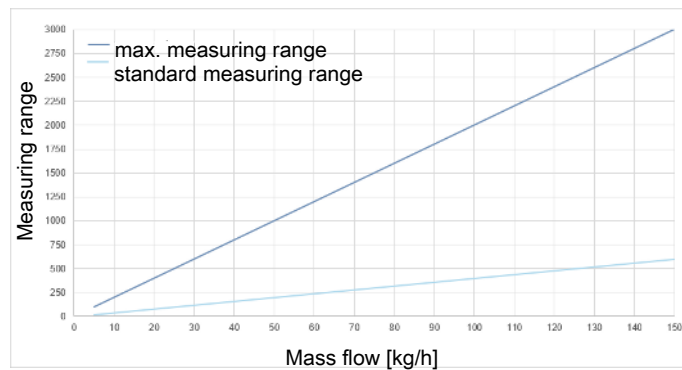

Fig. 13: Measurement range depending on nominal flow rate for DN2

MFC with pump

Mass flow rate range	Factory setting: 8 kg/h Higher value on request, minimum reducible to 2 kg/h
Measurement accuracy after 1 minute warm-up time	$\pm 0.2\%$ of the measured value PLUS ± 1.4 g/h. If $Q_{min} < 0.3$ kg/h, then the control accuracy can be lower. 1.4 g/h = zero-point stability
Maximum measurement range	1:160 The measurement range is defined as the ratio of $Q_{nominal}$ of the device to Q_{min} . $Q_{min} = 0.05$ kg/h. Refer to following figure.
Settling time (t95%)	< 1 s, for water at 20 °C The settling time depends on the medium used.

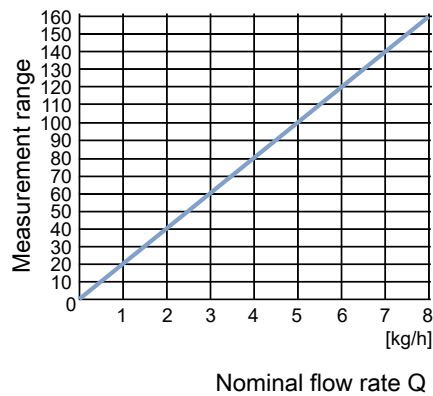

Fig. 14: Measurement range depending on nominal flow rate

MFC with proportional valve

Mass flow rate range	Factory setting: 25 kg/h Minimum reducible to 4 kg/h
Control accuracy after 1 minute warm-up time	$\pm 0.5\%$ of the measured value OR ± 0.012 kg/h. Take the highest value into account.
Maximum measurement range	> 1:300 The measurement range is defined as the ratio of Q_{nominal} of the device to Q_{min} . $Q_{\text{min}} = 0.08$ kg/h. Refer to following figure.
Settling time (t95%)	< 2 s, for water at 20 °C, without back pressure but with flow rate > 1 kg/h The settling time depends on the medium used.

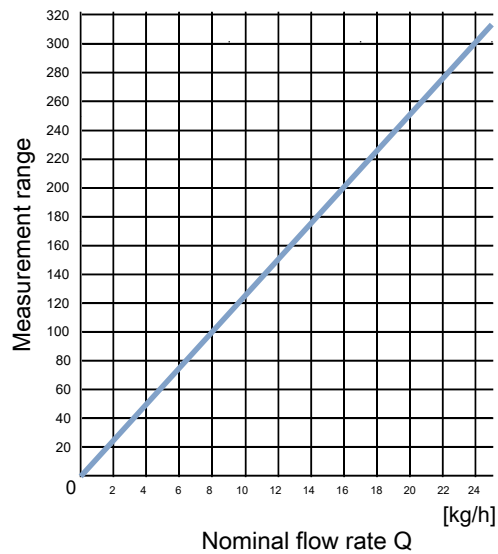

Fig. 15: Measurement range depending on nominal flow rate

MFC for modular actuator

Maximum mass flow rate	DN1: 30 kg/h DN2: 150 kg/h
Nominal mass flow rate	DN1: factory setting 30 kg/h (minimum reducible to Q _{nom} = 1 kg/h) DN2: factory setting 150 kg/h (minimum reducible to Q _{nom} = 5 kg/h)
Minimum measurable mass flow rate	DN1: factory setting 0.05 kg/h (can be reduced to 0.01 kg/h) DN2: factory setting 0.25 kg/h (can be reduced to 0.05 kg/h)
Measurement accuracy after 1 minute warm-up time	DN1: ±0.1% of the measured value or ±1.4 g/h. 1.4 g/h = zero-point stability ⁴⁾ DN2: ±0.1% of the measured value or ±10 g/h. 10 g/h = zero-point stability ⁵⁾
Maximum measurement range	1:3000 The measurement range is defined as the ratio of Q _{nominal} of the device to Q _{min} . Refer to following figure. DN1: Q _{min} = 0.05 kg/h DN2: Q _{min} = 0.25 kg/h
Repeatability	DN1: ±0.05% of the measured value or ±0.7 g/h DN2: ±0.05% of the measured value or ±5 g/h
Response time (t _{95%})	< 750 ms The response time depends on the medium used

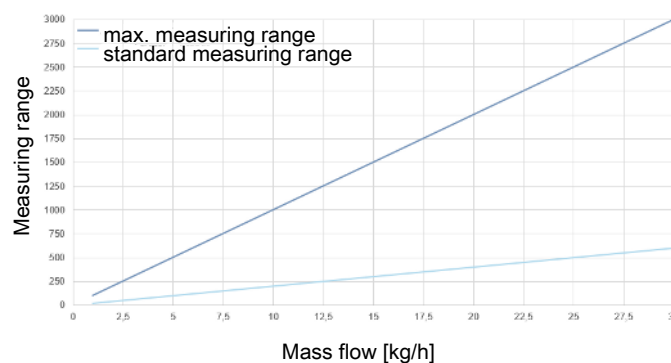

Fig. 16: Measurement range depending on nominal flow rate for DN1

⁴⁾ Zero point applies to water at calibration conditions; for flows of <1.4 kg/h and deviating medium, please consult Bürkert.

⁵⁾ Zero point applies to water at calibration conditions; for flows of <15 kg/h and deviating medium, please consult Bürkert.

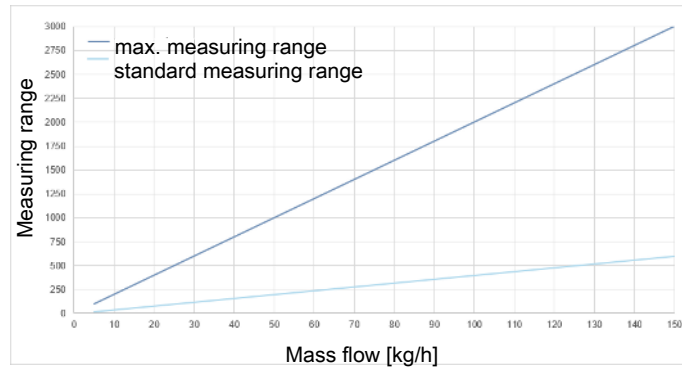

Fig. 17: Measurement range depending on nominal flow rate for DN2

4.3.6 Pressure loss

MFM

A MFM has a pressure loss that depends on the following parameters:

- the flow-rate value
- the size of the medium connections
- the type of the medium connections
- the size of the device base block
- the type of medium

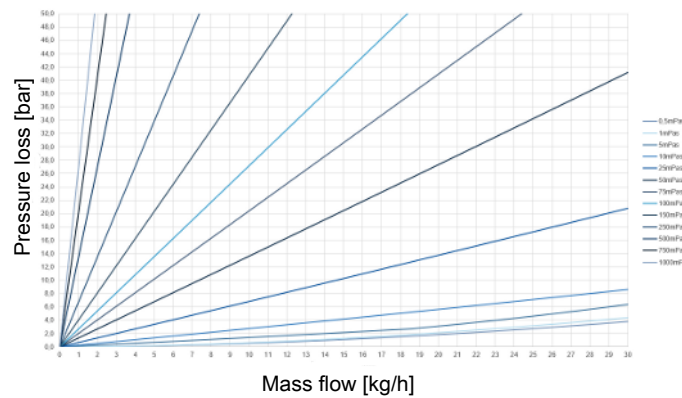

Fig. 18: Pressure loss diagram for DN1

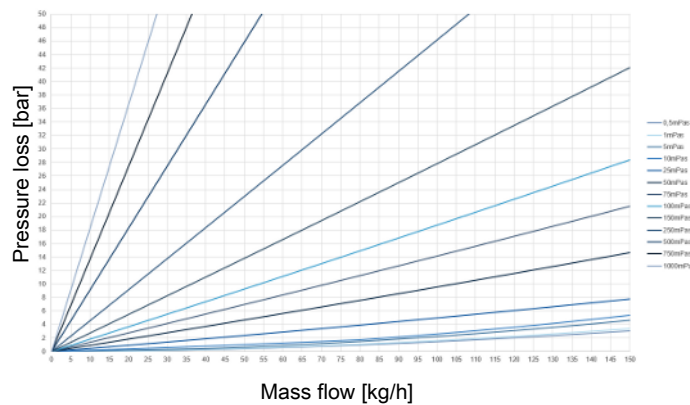

Fig. 19: Pressure loss diagram for DN2

MFC with pump

A MFC with pump has a pressure loss that depends on the medium.

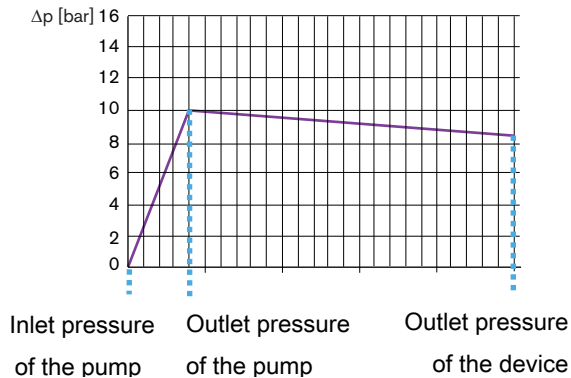

Fig. 20: Pressure loss diagram for water at 20 °C through an MFC with pump

MFC with proportional valve

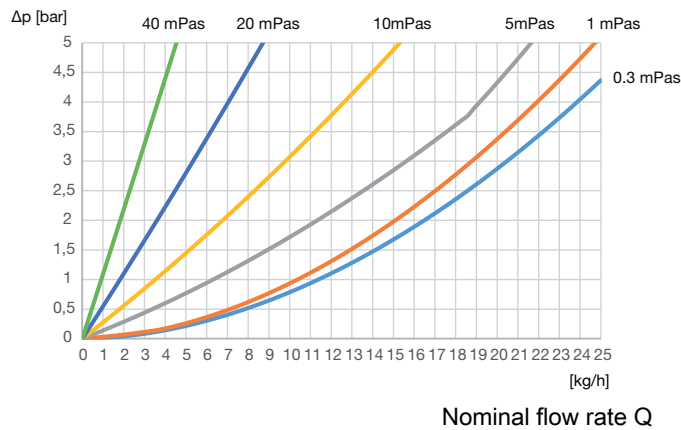

Fig. 21: Pressure loss diagram, MFC with proportional valve

MFC for modular actuator

An MFC for modular actuator has a pressure loss that depends on the following parameters:

- the flow-rate value
- the size of the medium connections
- the type of the medium connections
- the size of the device base block
- the type of medium
- the actuator

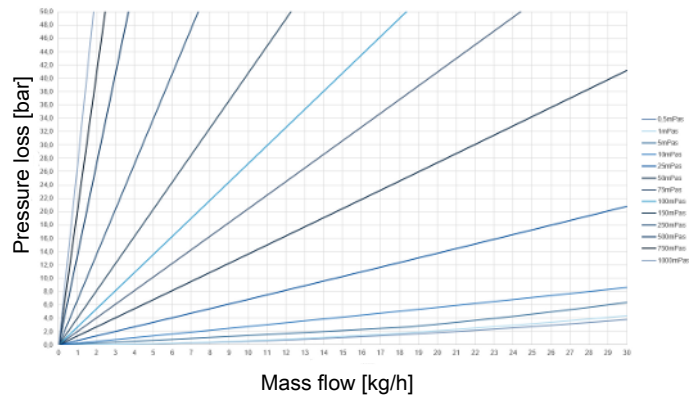

Fig. 22: Pressure loss diagram for DN1

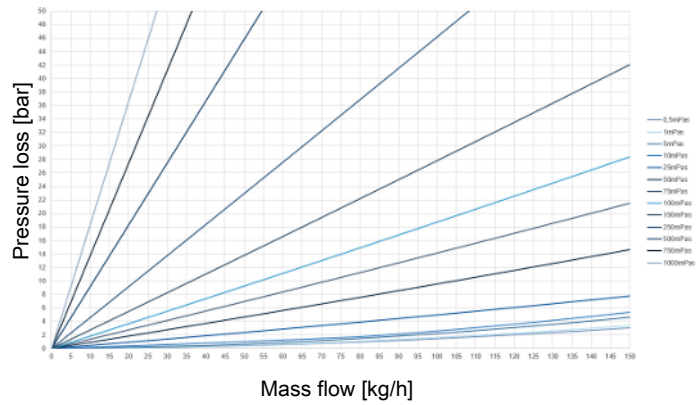

Fig. 23: Pressure loss diagram for DN2

4.4 Electrical data

MFM Analogue

Operating voltage	24 V $\overline{=}$ \pm 10 %
Power consumption	< 2 W
Analogue input for the measured value 0/4...20 mA	Maximum input impedance: 200 Ω Resolution: 5 μ A
Analogue input for the measured value 0...5/10 V	Minimum input impedance: 20 k Ω Resolution: 2,5 mV
Analogue output for the measured value 0/4...20 mA	Maximum loop impedance: 400 Ω at an operating voltage of 24 V $\overline{=}$ Resolution: 20 μ A
Analogue output for the measured value 0...5/10 V	Maximum current: 20 mA Resolution: 10 mV
Digital input	<ul style="list-style-type: none"> • 0...0.2 V to activate level 1 • 1...4 V or open to activate level 2 • 5...28 V to activate level 3
Relay output type	Change-over relay with 1 normally closed contact (break contact) and 1 normally open contact (make contact). Both contacts are free of potential
Maximum ratings	1 A, 30 V, 30 VA
Electrical connections	<ul style="list-style-type: none"> • M12 plug 5-pin A-coding • M12 socket 5-pin A-coding • service bÜS interface
Minimum temperature rating of the cable to be connected to the field wiring terminals:	75 °C

MFM Industrial Ethernet

Operating voltage	24 V \pm 10 %
Power consumption	< 2 W
Communication interface	Industrial Ethernet: PROFINET, EtherNet/IP, EtherCAT, Modbus TCP
Electrical connections	<ul style="list-style-type: none">• M12 plug 5-pin A-coding• 2 M8 socket 4-pin D-coding• service bÜS interface
Minimum temperature rating of the cable to be connected to the field wiring terminals:	75 °C

MFM bÜS/CANopen

Operating voltage	24 V \pm 10 %
Power consumption	< 2 W
Communication interface	bÜS and CANopen. The communication type can be selected with the Bürkert Communicator software.
Electrical connections	M12 plug 5-pin A-coding
Minimum temperature rating of the cable to be connected to the field wiring terminals:	75 °C

MFC Analogue with pump

Operating voltage	24 V $\overline{=}$ $\pm 10\%$ residual ripple < 2 %
Power consumption	< 67 W
Typical power consumption	16 W for water and at a flow rate of 8 kg/h
Analogue input for the measured value 0/4...20 mA	Maximum input impedance: 200 Ω Resolution: 5 μ A
Analogue input for the measured value 0...5/10 V	Minimum input impedance: 20 k Ω Resolution: 2,5 mV
Analogue output for the measured value 0/4...20 mA	Maximum loop impedance: 400 Ω at an operating voltage of 24 V $\overline{=}$ Resolution: 20 μ A
Analogue output for the measured value 0...5/10 V	Maximum current: 20 mA Resolution: 10 mV
Digital input	<ul style="list-style-type: none"> • 0...0.2 V to activate level 1 • 1...4 V or open to activate level 2 • 5...28 V to activate level 3
Relay output type	Change-over relay with 1 normally closed contact (break contact) and 1 normally open contact (make contact). Both contacts are free of potential
Maximum ratings	1 A, 30 V, 30 VA
Electrical connections	<ul style="list-style-type: none"> • M12 plug 5-pin A-coding • M12 socket 5-pin A-coding • service bÜS interface
Minimum temperature rating of the cable to be connected to the field wiring terminals:	75 °C

MFC Industrial Ethernet with pump

Operating voltage	24 V \pm 10 % residual ripple < 2 %
Power consumption	< 67 W
Typical power consumption	16 W for water and at a flow rate of 8 kg/h
Communication interface	Industrial Ethernet: PROFINET, EtherNet/IP, EtherCAT, Modbus TCP
Electrical connections	<ul style="list-style-type: none">• M12 plug 5-pin A-coding• 2 M8 socket 4-pin D-coding• service bÜS interface
Minimum temperature rating of the cable to be connected to the field wiring terminals:	75 °C

MFC bÜS/CANopen with pump

Operating voltage	24 V \pm 10 % residual ripple < 2 %
Power consumption	< 67 W
Typical power consumption	16 W for water and at a flow rate of 8 kg/h
Communication interface	bÜS and CANopen. The communication type can be selected with the Bürkert Communicator software.
Electrical connections	M12 plug 5-pin A-coding
Minimum temperature rating of the cable to be connected to the field wiring terminals:	75 °C

MFC Analogue with proportional valve

Operating voltage	24 V $\overline{=}$ $\pm 10\%$ residual ripple < 2 %
Power consumption	< 18 W
Typical power consumption	10 W for water and at a flow rate of 25 kg/h
Analogue input for the measured value 0/4...20 mA	Maximum input impedance: 200 Ω Resolution: 5 μ A
Analogue input for the measured value 0...5/10 V	Minimum input impedance: 20 k Ω Resolution: 2,5 mV
Analogue output for the measured value 0/4...20 mA	Maximum loop impedance: 400 Ω at an operating voltage of 24 V $\overline{=}$ Resolution: 20 μ A
Analogue output for the measured value 0...5/10 V	Maximum current: 20 mA Resolution: 10 mV
Digital input	<ul style="list-style-type: none"> • 0...0.2 V to activate level 1 • 1...4 V or open to activate level 2 • 5...28 V to activate level 3
Relay output type	Change-over relay with 1 normally closed contact (break contact) and 1 normally open contact (make contact). Both contacts are free of potential
Maximum ratings	1 A, 30 V, 30 VA
Electrical connections	<ul style="list-style-type: none"> • M12 plug 5-pin A-coding • M12 socket 5-pin A-coding • service bÜS interface
Minimum temperature rating of the cable to be connected to the field wiring terminals:	75 °C

MFC Industrial Ethernet with proportional valve

Operating voltage	24 V \pm 10 % residual ripple < 2 %
Power consumption	< 18 W
Typical power consumption	10 W for water and at a flow rate of 25 kg/h
Communication interface	Industrial Ethernet: PROFINET, EtherNet/IP, EtherCAT, Modbus TCP
Electrical connections	<ul style="list-style-type: none">• M12 plug 5-pin A-coding• 2 M8 socket 4-pin D-coding• service bÜS interface
Minimum temperature rating of the cable to be connected to the field wiring terminals:	75 °C

MFC bÜS/CANopen with proportional valve

Operating voltage	24 V \pm 10 % residual ripple < 2 %
Power consumption	< 18 W
Typical power consumption	10 W for water and at a flow rate of 25 kg/h
Communication interface	bÜS and CANopen. The communication type can be selected with the Bürkert Communicator software.
Electrical connections	M12 plug 5-pin A-coding
Minimum temperature rating of the cable to be connected to the field wiring terminals:	75 °C

MFC Analogue for modular actuator

Operating voltage	24 V \pm 10 %
Power consumption	< 2 W PLUS < 30 W (power consumption of the actuator)
PWM signal (actuator output)	Open collector, 22 k Ω -pull-up resistor and free wheeling diode, both to 24 V
Analogue input for the measured value 0/4...20 mA	Maximum input impedance: 200 Ω Resolution: 5 μ A
Analogue input for the measured value 0...5/10 V	Minimum input impedance: 20 k Ω Resolution: 2,5 mV
Analogue output for the measured value 0/4...20 mA	Maximum loop impedance: 400 Ω at an operating voltage of 24 V \pm Resolution: 20 μ A
Analogue output for the measured value 0...5/10 V	Maximum current: 20 mA Resolution: 10 mV
Analog output (actuator output)	0-10 V analog signal
Digital input	<ul style="list-style-type: none"> • 0...0.2 V to activate level 1 • 1...4 V or open to activate level 2 • 5...28 V to activate level 3
Digital output (actuator output)	5 V digital signal
Relay output type	Change-over relay with 1 normally closed contact (break contact) and 1 normally open contact (make contact). Both contacts are free of potential
Maximum ratings	1 A, 30 V, 30 VA
Electrical connections	<ul style="list-style-type: none"> • M12 plug 5-pin A-coding • M12 socket 5-pin A-coding • service b\ddot{u}S interface
Minimum temperature rating of the cable to be connected to the field wiring terminals:	75 $^{\circ}$ C

MFC Industrial Ethernet for modular actuator

Operating voltage	24 V \pm 10 %
Power consumption	< 2 W PLUS < 30 W (power consumption of the actuator)
PWM signal (actuator output)	Open collector, 22 k Ω -pull-up resistor and free wheeling diode, both to 24 V
Analog output (actuator output)	0-10 V analog signal
Digital output (actuator output)	5 V digital signal
Communication interface	Industrial Ethernet: PROFINET, EtherNet/IP, EtherCAT, Modbus TCP
Electrical connections	<ul style="list-style-type: none"> • M12 plug 5-pin A-coding • 2 M8 socket 4-pin D-coding • service b\ddot{u}S interface
Minimum temperature rating of the cable to be connected to the field wiring terminals:	75 °C

MFC b \ddot{u} S/CANopen for modular actuator

Operating voltage	24 V \pm 10 %
Power consumption	< 2 W PLUS < 30 W (power consumption of the actuator)
PWM signal (actuator output)	Open collector, 22 k Ω -pull-up resistor and free wheeling diode, both to 24 V
Analog output (actuator output)	0-10 V analog signal
Digital output (actuator output)	5 V digital signal
Communication interface	b \ddot{u} S and CANopen. The communication type can be selected with the Bürkert Communicator software.
Electrical connections	M12 plug 5-pin A-coding
Minimum temperature rating of the cable to be connected to the field wiring terminals:	75 °C

4.5 Communication

4.5.1 Industrial Ethernet: EtherCAT



Ethernet interface X1, X2	X1: EtherCAT IN X2: EtherCAT OUT
Acyclic communication (CoE)	SDO
Type	Complex Slave
FMMUs	8
Sync managers	4
Transmission speed	100 Mbit/s
Data transport layer	Ethernet II, IEEE 802.3

EtherCAT® is a registered trademark and patented technology, licensed by Beckhoff Automation GmbH, Germany.

4.5.2 Industrial Ethernet: EtherNet/IP

Pre-defined standard objects	Identity Object (0x01) Message Router Object (0x02) Assembly Object (0x04) Connection Manager (0x06) DLR Object (0x47) QoS Object (0x48) TCP/IP Interface Object (0xF5) Ethernet Link Object (0xF6)
DHCP	supported
BOOTP	supported
Transmission speed	10 and 100 Mbit/s
Duplex modes	Half duplex, full duplex, auto-negotiation
MDI modes	MDI, MDI-X, Auto-MDI-X
Data transport layer	Ethernet II, IEEE 802.3
Address Conflict Detection (ACD)	supported
DLR (ring topology)	supported
CIP reset service	Identity Object Reset Service Type 0 and Type 1

4.5.3 Industrial Ethernet: Modbus TCP

Modbus function codes	1, 2, 3, 4, 16
Transmission speed	10 and 100 Mbit/s
Data transport layer	Ethernet II, IEEE 802.3

4.5.4 Industrial Ethernet: PROFINET IO

Topology recognition	LLDP, SNMP V1, MIB2, Physical Device
Minimum cycle time	2 ms
IRT	not supported
MRP media redundancy	MRP client is supported
Other supported functions	DCP, VLAN Priority Tagging, Shared Device
Transmission speed	100 Mbit/s
Data transport layer	Ethernet II, IEEE 802.3
PROFINET IO specification	V2.43
Application Relations (AR)	The device can simultaneously process up to 2 IO ARs, 1 Supervisor AR, and 1 Supervisor DA AR.

4.6 Mechanical data

Dimensions	Refer to data sheet Type 8756
Base block	Stainless steel 316L
Housing	Painted aluminium, stainless steel
Seal	Refer to the type label
Status indicator	Polycarbonate
Parts in contact with the medium (sensor)	stainless steel 1.4404

MFM Alloy C22

Base block	Alloy C22
Parts in contact with the medium (sensor)	Alloy C22

MFC with proportional valve

Parts in contact with the medium	Stainless steel 303, stainless steel 434, stainless steel 301 The material depends on the equipped proportional valve
----------------------------------	--

5 Medium connection



Risk of injury or material damage when working on the device or system.

- ▶ Read and observe the chapter [Safety \[▶ 8\]](#) before working on the device or system.

5.1 Possible medium connections

MFM

- G-internal-threaded connections according to DIN ISO228/1
- NPT-internal-threaded connections according to ASME/ ANSI B 1.20.1
- Connections with external-threaded vacuum fittings
- Connections with external-threaded compression fittings
- Tri-Clamp

MFM Alloy C22

- Connections with external-threaded compression fittings

MFC

- G-internal-threaded connections according to DIN ISO228/1
- NPT-internal-threaded connections according to ASME/ ANSI B 1.20.1
- Connections with external-threaded vacuum fittings
- Connections with external-threaded compression fittings
- Tri-Clamp

5.2 Installation procedure

MFM



CAUTION!

Risk of injury that is due to leakage.

- ▶ At a low mass flow rate and a high pressure, make sure that the installation is tight. The tightness prevents incorrect measurements or the leakage of the medium.
- ▶ To make sure that the installation is tight, observe the following instruction: Use pipes with a diameter that is adapted to the medium connection of the device, and with a smooth surface.

NOTICE!

Malfunction that is due to contamination.

- ▶ If a contaminated medium is used, then install a filter upstream of the device. The filter ensures problem-free functioning of the device. Refer to [Medium data \[▶ 25\]](#)

NOTICE!

Cavitation of gas in the liquid and degassing must be avoided.

- ▶ To avoid cavitation and degassing, make sure that the medium is an homogeneous liquid and that the pressure in the pipe is high enough.
- ▶ When installing the device in the pipe, observe the flow direction that is given on the calibration plate of the device.
- ▶ If a external pump is used, then install the pump upstream of the device.

NOTICE!

- ▶ Do not use any pump in the installation because the flow rate must not pulsate.

No inlet section and no outlet section for flow conditioning are required.

- ▶ We recommend to install the device in a horizontal pipe or in a vertical pipe as shown in the following figures.

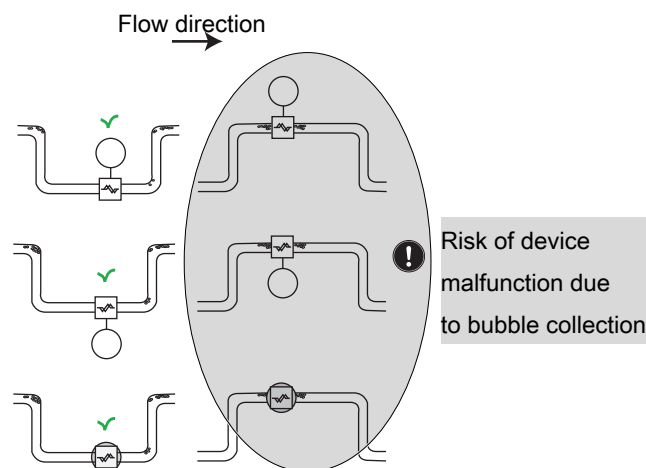

Fig. 24: Horizontal mounting positions

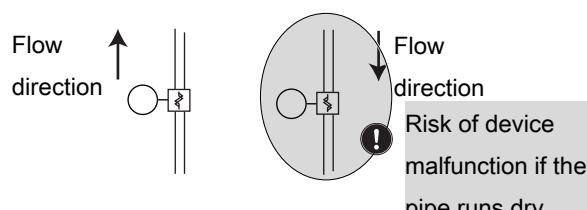

Fig. 25: Vertical mounting positions

MFC with pump



CAUTION!

Risk of injury that is due to leakage.

- ▶ Use pipes with a diameter that is adapted to the medium connection of the device, and with a smooth surface.
- ▶ To avoid possible problems that are due to leakage, make sure that no medium flows when the pump is switched off. Take into account the static pressure.

NOTICE!

Malfunction that is due to contamination.

- ▶ If a contaminated medium is used, then install a filter upstream of the device. The filter ensures problem-free functioning of the device. Refer to [Medium data \[▶ 25\]](#)

NOTICE!

Malfunction that is due to the damage of the device.

- ▶ Mount a mesh filter upstream of the device. The mesh size must be of max. 10 µm. Use the Type KF01 filter from Bürkert.

NOTICE!

Cavitation of gas in the liquid and degassing must be avoided.

- ▶ To avoid cavitation and degassing, make sure that the medium is an homogeneous liquid and that the pressure in the pipe is high enough.
- ▶ When installing the device in the pipe, observe the flow direction that is given on the calibration plate of the device.
- ▶ If a external pump is used, then install the pump upstream of the device.

NOTICE!

- ▶ Do not use any pump in the installation because the flow rate must not pulsate.

No inlet section and no outlet section for flow conditioning are required.

- ▶ We recommend to install the device in a horizontal pipe or in a vertical pipe as shown in the following figures.

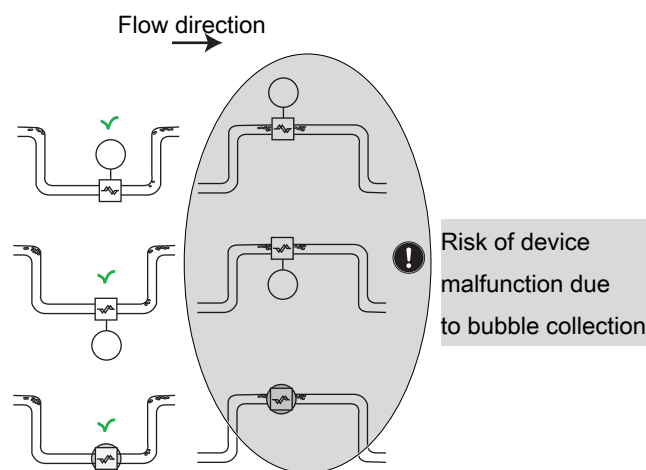

Fig. 26: Horizontal mounting positions

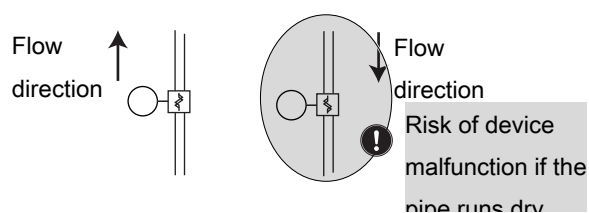

Fig. 27: Vertical mounting positions

MFC with proportional valve



CAUTION!

Risk of injury that is due to leakage.

- ▶ Use pipes with a diameter that is adapted to the medium connection of the device, and with a smooth surface.

NOTICE!

Malfunction that is due to contamination.

- ▶ If a contaminated medium is used, then install a filter upstream of the device. The filter ensures problem-free functioning of the device. Refer to [Medium data](#) [▶ 25]

NOTICE!

Cavitation of gas in the liquid and degassing must be avoided.

- ▶ To avoid cavitation and degassing, make sure that the medium is an homogeneous liquid and that the pressure in the pipe is high enough.
- ▶ When installing the device in the pipe, observe the flow direction that is given on the calibration plate of the device.
- ▶ If a external pump is used, then install the pump upstream of the device.

NOTICE!

- ▶ Do not use any pump in the installation because the flow rate must not pulsate.

No inlet section and no outlet section for flow conditioning are required.

- ▶ We recommend to install the device in a horizontal pipe or in a vertical pipe as shown in the following figures.

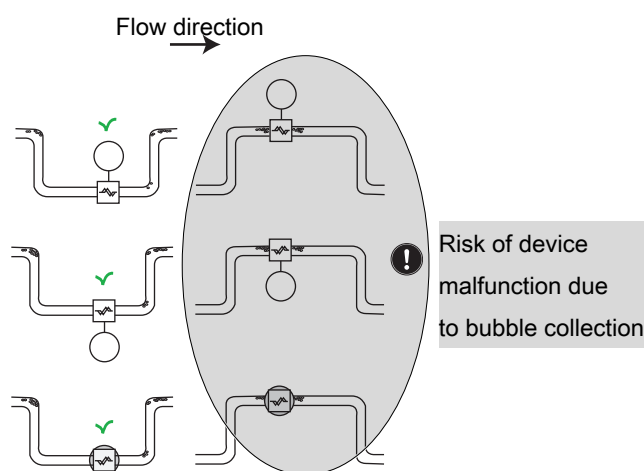

Fig. 28: Horizontal mounting positions

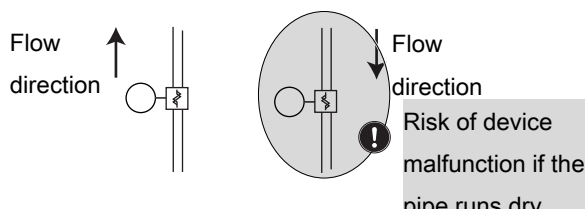

Fig. 29: Vertical mounting positions

MFC for modular actuator

NOTICE!

Malfunction that is due to contamination.

- ▶ If a contaminated medium is used, then install a filter upstream of the device. The filter ensures problem-free functioning of the device. Refer to [Medium data \[▶ 25\]](#)

NOTICE!

Cavitation of gas in the liquid and degassing must be avoided.

- ▶ To avoid cavitation and degassing, make sure that the medium is a homogeneous liquid and that the pressure in the pipe is high enough.
- ▶ When installing the device in the pipe, observe the flow direction that is given on the calibration plate of the device.
- ▶ If an external pump is used, then install the pump upstream of the device.

NOTICE!

- ▶ Do not use any pump in the installation because the flow rate must not pulsate.

No inlet section and no outlet section for flow conditioning are required.

- ▶ We recommend to install the device in a horizontal pipe or in a vertical pipe as shown in the following figures.

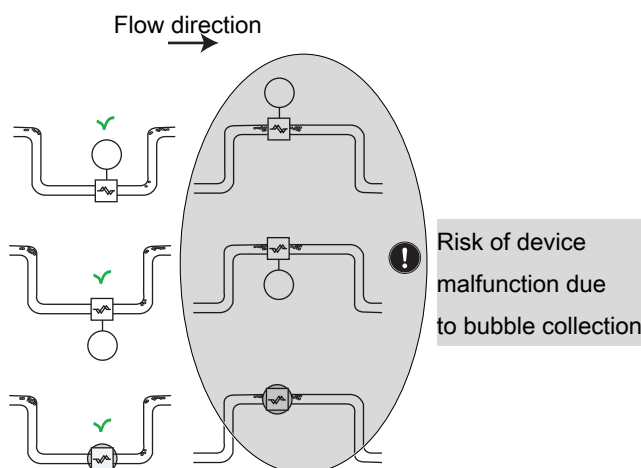

Fig. 30: Horizontal mounting positions

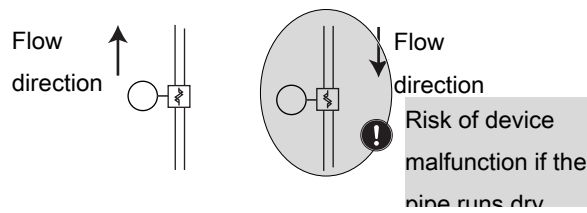

Fig. 31: Vertical mounting positions

5.2.1 G1/8"-internal-threaded connections

- ▶ Remove the protective cap that closes the threaded connection.
- ▶ Do the medium connection on one side of the device.
- ▶ Obey the instructions that are given by the manufacturer of the fitting used.
- ▶ Obey the torques that are given by the manufacturer of the fitting used.
- ▶ Do the medium connection on the other side of the device in the same way.

5.2.2 NPT1/8"-internal-threaded connections

- ▶ Do the medium connection on one side of the device.
- ▶ Obey the instructions that are given by the manufacturer of the fitting used.
- ▶ Obey the torques that are given by the manufacturer of the fitting used.
- ▶ Do the medium connection on the other side of the device in the same way.

5.2.3 Connections with external-threaded vacuum fittings

- ▶ Remove the protective cap that closes the connection.
- ▶ Do the medium connection on one side of the device.
- ▶ Obey the instructions that are given by the manufacturer of the fitting used.
- ▶ **CAUTION! To avoid damage on the sealing of the medium connection, please make sure to lock the hexagonal part in place with a second wrench.**
Obey the torques that are given by the manufacturer of the fitting used.
- ▶ Do the medium connection on the other side of the device in the same way.

5.2.4 Connections with external-threaded compression fittings

- ▶ Do the medium connection on one side of the device.
- ▶ Obey the instructions that are given by the manufacturer of the fitting used.
- ▶ **CAUTION! To avoid damage on the sealing of the medium connection, please make sure to lock the hexagonal part in place with a second wrench.**
Obey the torques that are given by the manufacturer of the fitting used.
- ▶ For the variant Alloy C22: screw the fitting in the base block and tighten it to a torque of 20 N·m.
- ▶ Do the medium connection on the other side of the device in the same way.

5.2.5 Tri-clamp connections

- ▶ Remove the protective cap that closes the threaded connection.
- ▶ Do the medium connection on one side of the device.
- ▶ Obey the instructions that are given by the manufacturer of the fitting used.
- ▶ Do the medium connection on the other side of the device in the same way.

6 Electrical connection



Risk of injury or material damage when working on the device or system.

- ▶ Read and observe the chapter [Safety \[▶ 8\]](#) before working on the device or system.

6.1 Additional documentation

Further documentation concerning the product:

- ▶ Access the page [Type 8756](#)
- ▶ Scroll down to **Downloads**
- ▶ Or enter the article number from the type label in the search bar.

6.2 Wire the variant büS /CANopen

NOTICE!

UL approved versions must be supplied in one of the following ways:

- ▶ "Limited Energy Circuit" (LEC), according to UL / IEC61010-1
- ▶ "Limited Power Source" (LPS), according to UL / IEC60950
- ▶ SELV / PELV with UL-approved overcurrent protection, designed according to UL / IEC61010-1, Table 18 (e.g. Block PM-0124-020-0)
- ▶ NEC Class 2 power supply unit

6.2.1 With büS extension cables from Bürkert



Requirements for the correct operation of the device: refer to the Cabling Guide | büS/EDIP.

- ▶ Access the page [Type 8756](#)
- ▶ Scroll down to **Downloads** > **User Manuals**

To wire the device, use büS extension cables from Bürkert.

- ▶ Screw the mating female connector onto the 5-pin male connector. Apply the tightening torque specified by the manufacturer of the mating female connector.
- ▶ Do the functional earthing of the device. Refer to [Connect the functional earth \[▶ 63\]](#).

6.2.2 With büS cables from Bürkert



Requirements for the correct operation of the device: refer to the Cabling Guide | büS/EDIP.

- ▶ Access the page [Type 8756](#)
- ▶ Scroll down to **Downloads** > **User Manuals**

To wire the device, büS cables and mating female connectors are available from Bürkert.

If a bus cable from Bürkert is used, then observe the signals of the conductors.

Colour of the bus cable conductor	Signal
red	24 V \equiv
black	GND
white	CAN_H
blue	CAN_L

Tab. 3: Signals of the bus cable conductors

NOTICE!

If an own mating female connector is used, then observe the following requirements for the correct operation of the device.

- ▶ Use a mating female connector with shield connection.
- ▶ Make sure that the bus cable passes through the mating female connector. The bus cable that is available from Bürkert has an external diameter of 8.2 mm.

5-pin M12 male connector (A coding)	Pin	Assignment
	1	Shield
	2	24 V \equiv
	3	GND
	4	CAN_H
	5	CAN_L
	6	Coding lug

M12 thread is internally connected to FE

Tab. 4: Pin assignment, 5-pin M12 male connector (A coding) of the device

- ▶ Wire the mating female connector. Observe the instructions that are given by the manufacturer of the mating female connector.
- ▶ Insert each conductor into the appropriate pin.
- ▶ Take a strand of the cable shielding and insert the strand into pin 1.
- ▶ Screw the mating female connector to the 5-pin male connector, to the torque given by the manufacturer of the mating female connector.
- ▶ Do the functional earthing of the device. Refer to [Connect the functional earth \[▶ 63\]](#)

6.2.3 With CANopen cables



Requirements for the correct operation of the device.

- ▶ Use shielded CANopen cables. The cable shielding can be either a braid shielding or a foil shielding.

To wire the device, mating female connectors are available from Bürkert.

NOTICE!

Requirements for the correct operation of the device.

- ▶ Use a mating female connector with shield connection.
- ▶ Observe the specifications for the cable and conductors, that are given by the manufacturer of the mating female connector.

5-pin M12 male connector (A coding)	Pin	Assignment
	1	Shield
	2	24 V \equiv
	3	GND
	4	CAN_H
	5	CAN_L
	6	Coding lug

M12 thread is internally connected to FE

Tab. 5: Pin assignment, 5-pin M12 male connector (A coding) of the device

- ▶ Wire the mating female connector. Observe the instructions that are given by the manufacturer of the mating female connector.
- ▶ Insert each conductor into the appropriate pin.
- ▶ Take a strand of the cable shielding and insert the strand into pin 1.
- ▶ Screw the mating female connector to the 5-pin male connector, to the torque given by the manufacturer of the mating female connector.
- ▶ Do the functional earthing of the device. Refer to [Connect the functional earth \[▶ 63\]](#)

6.3 Wire the variant Analogue



Requirements for the correct operation of the device.

- ▶ Use shielded cables. The cable shielding can be either a braid shielding or a foil shielding.

NOTICE!

Requirements for the correct operation of the device.

- ▶ Use a mating female connector with shield-connection transfer at the union nut.
- ▶ Use a mating male connector with shield-connection transfer at the union nut.
- ▶ Use a mating male connector and a mating female connector that are in metal.
- ▶ Observe the specifications for the cable and conductors, that are given by the manufacturer of the mating female or male connector.

NOTICE!

UL approved versions must be supplied in one of the following ways:

- ▶ "Limited Energy Circuit" (LEC), according to UL / IEC61010-1
- ▶ "Limited Power Source" (LPS), according to UL / IEC60950
- ▶ SELV / PELV with UL-approved overcurrent protection, designed according to UL / IEC61010-1, Table 18 (e.g. Block PM-0124-020-0)
- ▶ NEC Class 2 power supply unit

MFM

5-pin M12 male connector	Pin	Assignment
	1	GND for the analogue output
	2	24 V ---
	3	GND
	4	Not connected
	5	Analogue output for the measured value
	6	Coding lug

M12 thread is internally connected to FE

Tab. 6: Pin assignment, 5-pin M12 male connector (A coding) of the device

MFC

5-pin M12 male connector	Pin	Assignment
	1	GND for the analogue output and the set-point input
	2	24 V $\overline{=}$
	3	GND
	4	Set-point input
	5	Analogue output for the measured value
	6	Coding lug

M12 thread is internally connected to FE

Tab. 7: Pin assignment, 5-pin M12 male connector (A coding) of the device

- ▶ Wire the mating female connector according to the pin assignment of the M12 male connector. Observe the instructions that are given by the manufacturer of the mating female connector.
- ▶ Connect the cable shielding to the mating female connector.
- ▶ Screw the mating female connector to the 5-pin male connector, to the torque that is given by the manufacturer of the mating female connector.

5-pin M12 female connector	Pin	Assignment
	1	GND for the digital input
	2	Digital input +
	3	Relay - Reference contact
	4	Relay - Normally closed contact (Break contact)
	5	Relay - Normally open contact (Make contact)
	6	Coding lug

M12 thread is internally connected to FE

Tab. 8: Pin assignment, 5-pin M12 female connector of the device

- ▶ Wire the mating male connector according to the pin assignment of the M12 female connector. Observe the instructions that are given by the manufacturer of the mating male connector.
- ▶ Connect the cable shielding to the mating male connector.
- ▶ Screw the mating male connector to the 5-pin female connector, to the torque given by the manufacturer of the mating male connector.
- ▶ Do the functional earthing of the device. Refer to [Connect the functional earth \[▶ 63\]](#)

6.3.1 Digital input

The 5-pin M12 female connector has a digital input. A digital input is used to remotely trigger a function.

Available functions on MFM

- Reset the totalizer for the active medium.

Default assignment

Reset totalizer

Available functions on MFC

- Reset the totalizer for the active medium.
- Start the function autotune.
- Trigger the remote control of the actuator or trigger the control of the actuator by the device.
- Select the set-point value.

Default assignment

Start autotune

- ▶ To select the function to be remotely triggered over the digital input, use the Bürkert Communicator software. Only one of the available functions can be associated to the digital input.

A function has up to 3 possible switching levels which may trigger different actions. The following table gives the actions that are associated to the switching levels, and how each level is activated.

MFM | Digital input 1 inverted

Function	Level 1 "low" ⁶⁾	Level 2 "open" ⁷⁾	Level 3 "high" ⁸⁾
Reset totalizer	Resets the Totalizer	-	-

Tab. 9: Actions triggered by the switching levels

MFM | Digital input 1 not inverted

Function	Level 1 "low" ⁶⁾	Level 2 "open" ⁷⁾	Level 3 "high" ⁸⁾
Reset totalizer	-	-	Resets the Totalizer

Tab. 10: Actions triggered by the switching levels

⁶⁾ Digital input is connected to GND

⁷⁾ Digital input is not connected (alternatively: 1..4 V $\overline{\text{---}}$)

⁸⁾ Digital input is connected to +24 V $\overline{\text{---}}$ (alternatively: 5...28 V $\overline{\text{---}}$)

MFC | Digital input 1 inverted

Function	Level 1 "low" ⁹⁾	Level 2 "open" ¹⁰⁾	Level 3 "high" ¹¹⁾
Start autotune	Starts Autotune	-	-
Set-point value source	Triggers Stored set-point active	-	Triggers Open-loop control mode
Reset totalizer	Resets the Totalizer	-	-
Actuator control	Opens the actuator completely	-	Closes the actuator
Close actuator	Closes the actuator	-	-
Open actuator	Opens the actuator completely	-	-

Tab. 11: Actions triggered by the switching levels

MFC | Digital input 1 not inverted

Function	Level 1 "low" ⁹⁾	Level 2 "open" ¹⁰⁾	Level 3 "high" ¹¹⁾
Start autotune	-	-	Starts Autotune
Set-point value source	Triggers Open-loop control mode	-	Triggers Stored set-point active
Reset totalizer	-	-	Resets the Totalizer
Actuator control	Closes the actuator	-	Opens the actuator completely
Close actuator	-	Closes the actuator	Closes the actuator
Open actuator	-	-	Opens the actuator completely

Tab. 12: Actions triggered by the switching levels

6.3.2 Relay output

The 5-pin M12 female connector has a relay output.

⁹⁾ Digital input is connected to GND

¹⁰⁾ Digital input is not connected (alternatively: 1..4 V $\overline{\text{---}}$)

¹¹⁾ Digital input is connected to +24 V $\overline{\text{---}}$ (alternatively: 5...28 V $\overline{\text{---}}$)

MFM

The relay switching can show the following events:

- A warning message has been generated. For example if the supply voltage is too high, then a warning message is generated.
- A failure message has been generated. For example if a sensor failure is detected, then a failure message is generated.

Default assignment

Empty pipe detected

Gas bubbles in the system

MFC

The relay switching can show the following events:

- A warning message has been generated. For example if the supply voltage is too high, then a warning message is generated.
- A failure message has been generated. For example if a sensor failure is detected, then a failure message is generated.
- The set-point value cannot be reached.
- The device is doing an Autotune.
- The **Set-point value source** has changed.

Default assignment

The set-point value cannot be reached

- ▶ To select the events that are assigned to the relay output, use the Bürkert Communicator software. Several events can be associated to the relay output.

6.4 Wire the variant Industrial Ethernet

NOTICE!

Requirements for the correct operation of the device.

- ▶ Use a power supply unit with sufficient power.
- ▶ Use only Industrial Ethernet shielded cables with a category CAT-5e or higher.
- ▶ Connect each cable end to the functional earth.
- ▶ For an MFC pay attention to the maximum permissible residual ripple on the operating voltage (residual ripple < 2 %).

NOTICE!

UL approved versions must be supplied in one of the following ways:

- ▶ "Limited Energy Circuit" (LEC), according to UL / IEC61010-1
- ▶ "Limited Power Source" (LPS), according to UL / IEC60950
- ▶ SELV / PELV with UL-approved overcurrent protection, designed according to UL / IEC61010-1, Table 18 (e.g. Block PM-0124-020-0)
- ▶ NEC Class 2 power supply unit

5-pin M12 male connector (A coding)	Pin	Assignment
	1	Shielding
	2	24 V \equiv
	3	GND
	4	Not connected
	5	Not connected
	6	Coding lug
M12 thread is internally connected to FE		

Tab. 13: Pin assignment, 5-pin M12 male connector (A coding) of the device

4-pin M8 female connector (D coding)	Pin	Assignment
	1	Tx +
	2	Rx +
	3	Tx -
	4	Rx -
	5	Coding lug
M8 thread is internally connected to FE		

Tab. 14: Pin assignment, 4-pin M8 (D coding) of the device

- ▶ If a protocol other than EtherCAT is used, plug an Ethernet cable in one or both sockets.

- ▶ If the EtherCAT protocol is used, plug the incoming Ethernet cable (coming from the PLC) into the socket marked ETH1 and plug the outgoing Ethernet cable into the socket marked ETH2.

6.5 Change the network parameters

Industrial Ethernet variant



The Industrial Ethernet variants Ethernet/IP and ModbusTCP have the same default IP address 192.168.1.100, Profinet devices have 0.0.0.0 by default.

- ▶ Before commissioning the device, change its network parameters.
- ▶ If several devices must be connected to the same Industrial Ethernet network, then connect one device at a time and change its network parameters.

6.5.1 Over the product web server

NOTICE!

Security risk due to default passwords.

Unauthorised persons can log in to the web server and change the parameters.

- ▶ Change the default passwords.
- ▶ If the web server is not required, disable access using Bürkert Communicator. Refer to [Configuration with Bürkert Communicator \[▶ 67\]](#).

Prerequisites:

- The industrial Ethernet variant is not EtherCAT
- Digital device (PC, tablet,...) with a web browser.
- Possibly, a USB-Ethernet adapter.
- ▶ Connect the device to the digital device with an Ethernet cable. Alternatively, connect the device to the PC with a USB-Ethernet adapter.
- ▶ Energise the digital device and the device.
- ▶ If the device is connected to the digital device over a USB-Ethernet adapter, then configure the IP address of the USB-Ethernet adapter. Else, configure the IP address of the network card of the digital device.
- ▶ Change the IP address to 192.168.1.xxx, where xxx is different from 100.
- ▶ Open the web browser. In the address bar of the web browser, enter 192.168.1.100.
 - ✓ The home page of the web server opens. Some device data are shown.
- ▶ Open a web server session, to configure the network parameters of the device.
- ▶ If you are not automatically invited to log in, select **Login**.
- ▶ **User name**: enter admin
- ▶ **User password**: enter admin
- ▶ Click **Login**.
- ▶ Change the default passwords with customised passwords.
- ▶ Change the network parameters of the device.

- ▶ Select **Industrial communication** > **Configuration**.
- ▶ Change the parameters.
- ▶ To save the changes, select **Apply**.
- ▶ To update the parameters, select **Restart**.
- ✓ The device restarts.
- ✓ The network parameters of the device are changed.

6.5.2 Over the Bürkert Communicator software

- ▶ Connect the device to the Bürkert Communicator software. Refer to [Configuration with Bürkert Communicator \[▶ 67\]](#).
- ▶ Change the network parameters of the device.
- ▶ Select **Industrial communication** > **Parameter**.
- ▶ Change the parameters.
- ▶ To update the parameters, restart the device.
- ✓ The device restarts.
- ✓ The network parameters of the device are changed.

6.6 Connect the functional earth



WARNING!

Risk of ignition and risk of fire that are due to electrostatic discharge.

An electrostatic discharge of the device can ignite combustible gas vapours.

- ▶ To avoid a build up of electrostatic charge, connect the housing to the functional earth.
- ▶ If the functional earth is not attached, then the requirements of the EMC directive are not met.

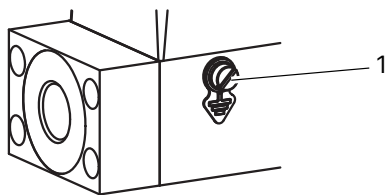

Fig. 32: Location of the M4 screw for the connection of the functional earth

1 M4 screw

- ▶ Use a green-and-yellow cable that is as short as possible. And the cable cross-section must be at least equal to the cross section of the power-supply cable.
- ▶ With a flat screwdriver of size 6.5 mm, loosen the M4 screw.
- ▶ Attach the green-and-yellow cable to the M4 screw with a cable lug.
- ▶ Tighten the M4 screw to a torque of 1,8 N·m...2 N·m (1,33 lbf·ft...1,47 lbf·ft).

6.7 Connect the external actuator

MFC for modular actuator

To wire the device, mating male connectors are available from Bürkert.

8-pin M12 female connector	Pin	Assignment
	1	24 V
	2	GND
	3	0-10 V output
	4	0-10 V GND
	5	Digital output (5 V level)
	6 ¹²⁾	PWM (open collector)
	7	Internal use only
	8	Not connected
	9	Coding lug
	Housing	FE

Tab. 15: Pin assignment, 8-pin M12 female connector

- ▶ Wire the mating male connector according to the pin assignment of the M12 female connector. Observe the instructions that are given by the manufacturer of the mating male connector.
- ▶ Screw the mating male connector to the 8-pin female connector, to the torque given by the manufacturer of the mating male connector.

Refer to [Configure the actuator \[▶ 73\]](#).

6.7.1 Connection examples with Bürkert valves

Valve	Device example	Connection
Proportional valves	Type 2873	Use pin 1 and 6.
On/off valves	Type 6727, 6757, 6013	Use pin 1 and 6.
EVA valves	Type 3280	Use pin 1 and 2 for supply. Use pin 6 or 3+4 for signal (depending on variant).
Pumps		Use pin 1 and 2 for supply. Use pin 5+6 or 3+4+5 for signal (depending on variant).

¹²⁾ 22 kΩ-pull-up resistor and free wheeling diode, both to 24 V, active low.

7 Commissioning



Risk of injury or material damage when working on the device or system.

- ▶ Read and observe the chapter [Safety \[▶ 8\]](#) before working on the device or system.

7.1 Commissioning procedure



The operation of the device is tested at the factory with medium. Residual medium can remain in the device.



If the memory card is defective or lost, then buy a new one from your Bürkert sales office.

MFM

- ▶ No zero adjustment is needed.
- ▶ Pressurise the pipes with medium.
- ▶ Flush the pipes with medium.
- ▶ Vent the pipes completely.
- ▶ Check if the memory card is inserted.
- ▶ Energise the device.
- ▶ Variant büS /CANopen: Choose between CANopen communication and büS communication. Refer to [Set the CANopen communication or the büS communication \[▶ 73\]](#)

MFC with pump



If the pipes are empty and vented, and if the pump runs dry, then the pump of the MFC can be damaged.

- ▶ Set the set-point value to 0.
- ▶ Fill the pipe. Refer to [Fill the pipe without damaging the pump \[▶ 66\]](#).
- ▶ Check if the memory card is inserted.
- ▶ Energise the device.
- ▶ Variant büS /CANopen: Choose between CANopen communication and büS communication. Refer to [Set the CANopen communication or the büS communication \[▶ 73\]](#)
- ▶ Run the Autotune function. Refer to [Optimise the closed-loop control parameters \[▶ 77\]](#)

MFC with proportional valve

- ▶ No zero adjustment is needed.
- ▶ Pressurise the pipes with medium.
- ▶ Make sure that the proportional valve is completely open.
- ▶ Flush the pipes with medium.
- ▶ Vent the pipes completely.

- ▶ Flush bubbles from the pipes. Refer to [Flush bubbles from the pipe \[▶ 72\]](#)
- ▶ Check if the memory card is inserted.
- ▶ Energise the device.
- ▶ Variant būs /CANopen: Choose between CANopen communication and būs communication. Refer to [Set the CANopen communication or the būs communication \[▶ 73\]](#)
- ▶ Run the Autotune function. Refer to [Optimise the closed-loop control parameters \[▶ 77\]](#)

MFC for modular actuator

- ▶ No zero adjustment is needed.
- ▶ Pressurise the pipes with medium.
- ▶ Configure the connected actuator. Refer to [Configure the actuator \[▶ 73\]](#)
- ▶ Flush the pipes with medium.
- ▶ Vent the pipes completely.
- ▶ Check if the memory card is inserted.
- ▶ Energise the device.
- ▶ Variant būs /CANopen: Choose between CANopen communication and būs communication. Refer to [Set the CANopen communication or the būs communication \[▶ 73\]](#)

7.2 Fill the pipe without damaging the pump

MFC with pump

To make sure that the pump is not damaged when filling the pipe, proceed as follows:

- ▶ Connect the device to the Bürkert Communicator software. Refer to [Connect to the Bürkert Communicator \[▶ 67\]](#)
- ▶ Select the device.
- ▶ Make sure that the medium can flow.
- ▶ Make sure that the suction pressure does not exceed 200 mbar during the full procedure.
- ▶ Select **Controller** > **Set-point value source** > **Open-loop control mode**
 - ✓ The status indicator is orange.
 - ✓ A check-function event is generated.
- ▶ Select **Actuator** > **Actuating variable**
- ▶ Set 15%.
- ▶ Wait for 60 seconds. If the device still detects that the pipe is empty, then contact Bürkert.
- ▶ Select **Controller** > **Set-point value source** > **Automatic**

8 Configuration with Bürkert Communicator

8.1 Setting tools



The MassFlowCommunicator is another PC software that is not compatible with the device. The MassFlowCommunicator software cannot be used to configure or operate the device.

Settings can be made with the Type 8920 Bürkert Communicator. For general information about the Bürkert Communicator, refer to the operating instructions of Type 8920.

- ▶ Access the page [Type 8920](#)
- ▶ Scroll down to **Downloads** > **User Manuals**

8.2 Connect to the Bürkert Communicator

Analogue variant | Industrial Ethernet variant

- ▶ Use the USB-büS-Interface set, article number 00772551.
- ▶ Download the latest version of the Type 8920 Bürkert Communicator.
- ▶ Access the page [Type 8920](#)
- ▶ Scroll down to **Downloads** > **Software**
- ▶ Install the Bürkert Communicator on a PC. During installation, the büS stick must not be connected to the PC.
- ▶ Assemble the parts of the USB-büS-Interface set.



Fig. 33: Assembled parts of the USB-büS-Interface set

- ▶ Set the termination-resistance switch of the büS stick to ON.
- ▶ Insert the büS stick into a USB port of the PC.
- ▶ Energise the device. Refer to [Electrical connection \[▶ 53\]](#)
- ▶ Insert the micro-USB connector into the büS interface of the device. Refer to [Product description \[▶ 11\]](#)
- ▶ Wait until the driver of the büS stick has been completely installed on the PC.
- ▶ Start the Bürkert Communicator.



- ▶ Click on  in the Bürkert Communicator to establish the communication with the device.

Type 8756

Configuration with Bürkert Communicator

✓ A window opens.

- ▶ Select **Connect via USB (büs Stick)**.
- ▶ Select the port Bürkert USB büS stick, click on **Finish** and wait until the device symbol appears in the list of devices.
- ▶ In the navigation area, click on the symbol related to the device: The device menu appears.

büs / CANopen variant

- ▶ Use the USB-büs-Interface set, article number 00772426.



Fig. 34: USB-büs-Interface set

1 büS stick with termination-resistance switch

- ▶ Download the latest version of the Type 8920 Bürkert Communicator.
- ▶ Access the page [Type 8920](#)
- ▶ Scroll down to **Downloads > Software**
- ▶ Install the Bürkert Communicator on a PC. During installation, the büS stick must not be connected to the PC.

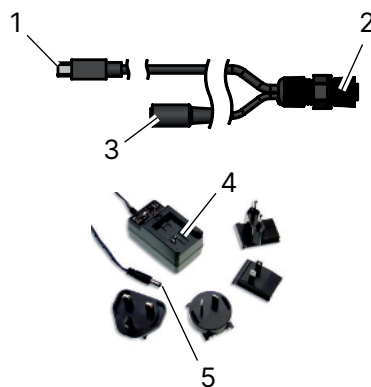



Fig. 35: Electrical connection parts of the USB-büs-Interface set

1 Micro-USB connector	2 5-pin M12 female connector
3 Jack female connector	4 AC/DC adapter
5 Jack male connector	

- ▶ Insert the micro-USB plug into the büS stick.
- ▶ Insert the appropriate power adapter into the AC/DC adapter.

- ▶ Connect the jack male-connector of the AC/DC-adapter cable to the jack female-connector of the M12 female-connector cable.
- ▶ Connect the M12 female connector to the bÜS network.
- ▶ If the device is connected to a bÜS network and is at a bÜS end, then set the bÜS stick switch to "ON". The termination resistance that is integrated in the bÜS stick is then activated.
- ▶ Insert the bÜS stick into a USB port of the PC.
- ▶ Wait until the Windows pilot of the bÜS stick has been completely installed on the PC.
- ▶ Connect the AC/DC adapter to the power supply.
- ▶ Start the Bürkert Communicator.



- ▶ Click on  in the Bürkert Communicator to establish the communication with the device.
 - ✓ A window opens.
- ▶ Select **Connect via USB (bÜS Stick)**.
- ▶ Select the port Bürkert USB bÜS stick, click on **Finish** and wait until the device symbol appears in the list of devices.
- ▶ In the navigation area, click on the symbol related to the device: The device menu appears.

8.3 User levels in the Bürkert Communicator



The Bürkert Communicator has the following user levels User, Advanced user and Installer.

After installation of the Bürkert Communicator, the user level Installer is active and password protection is deactivated.

NOTICE!

Security risk due to deactivated password protection and default password
 Unauthorised persons can make changes to the system.

- ▶ Enable password protection.
- ▶ Use user-defined password.

Symbol	User level	Description
	User	Lowest user level, read authorisation, can change few values. No password
	Advanced user	Can change certain values and perform simple calibrations. Standard password: 5678
	Installer	Has all authorisations for operating the Bürkert Communicator. Standard password: 1946

Tab. 16: The active user level is indicated by an icon in the top left-hand area of the screen.

8.3.1 Enabling password protection

Setting a password enables password protection.

NOTICE!

Security risk due to standard passwords.

The default passwords are publicly accessible and therefore not secure. Unauthorised persons can log in to the web server and make changes to the system.

- ▶ Use user-defined passwords.
- ▶ Select **Options** > **Password manager...**
- ▶ Enter user-defined passwords.
- ▶ **Save**

8.3.2 Activating or deactivating user level

Activate the password-protected user level:

- ▶ Click on the user level icon (top left of the screen).
- ▶ Enter password.
- ✓ The user level with password protection is active.

Deactivate the password-protected user level:

- ▶ Click on the user level icon.
- ▶ **Logout**
- ✓ The user level without password protection is active.

8.4 Functions

8.4.1 Empty-pipe detection

To detect when the pipe is empty, the device monitors the density value of the liquid.

If the density value is lower than 0.2 kg/l, then the pipe is empty and there is a warning with the following means:

- The status indicator is yellow.
- An out-of-specification event is generated.

MFC with pump

- ▶ If needed, fill the pipe. Refer to [Fill the pipe without damaging the pump \[▶ 66\]](#)

8.4.2 Bubble detection

The device detects when there are bubbles in the liquid.

If there are bubbles in the liquid, then there is a warning with the following means:

- The status indicator is yellow.
- An out-of-specification event is generated.

MFM

- ▶ Increase the medium pressure.
- ▶ Do not use a medium that is saturated with air.
- ▶ Observe the installation procedure.

MFC with pump

- ▶ Flush bubbles from the pipe. Refer to [Flush bubbles from the pipe \[▶ 72\]](#)

MFC with proportional valve

- ▶ Flush bubbles from the pipe. Refer to [Flush bubbles from the pipe \[▶ 72\]](#)

8.4.3 Cut-off

If the device measures a mass flow rate value that is under a set limit, then the device transmits a zero mass flow rate.

MFM

Cut-off limit	DN1: 0.05 kg/h
Default value	DN2: 0.25 kg/h

MFC with pump

Cut-off limit	0.05 kg/h
Default value	

MFC with proportional valve

Cut-off limit	0.02 kg/h
Default value	

MFC for modular actuator

Cut-off limit	DN1: 0.05 kg/h
Default value	DN2: 0.25 kg/h

Set the cut-off limit with the Bürkert Communicator software:

- ▶ Connect the device to the Bürkert Communicator software. Refer to [Connect to the Bürkert Communicator \[▶ 67\]](#)
- ▶ In the Bürkert Communicator software, select the device.
 - ✓ The status indicator flashes.
- ▶ Select **Sensor > Parameter > Advanced > Limit on low cutoff**
- ▶ Set the cut-off limit in the range that is displayed.

- ✓ The cut-off limit is set.

8.4.4 Flush bubbles from the pipe

To make sure that there are no bubbles in the pipe, do the following procedure:

MFC with pump

- ▶ Fill the pipe. Refer to [Fill the pipe without damaging the pump \[▶ 66\]](#).
- ▶ Connect the device to the Bürkert Communicator software. Refer to [Connect to the Bürkert Communicator \[▶ 67\]](#)
- ▶ Select the device.



WARNING!

Risk of injury from flowing medium.

While the procedure is running, the mass flow rate value can be higher than the nominal flow rate value.

- ▶ Before running the procedure, make sure that no danger can occur if the mass flow rate value increases.
- ▶ Select **Controller** > **Set-point value source** > **Open-loop control mode**
 - ✓ The status indicator is orange.
 - ✓ A check-function event is generated.
- ▶ Select **Actuator** > **Actuating variable**
- ▶ Set 50% > wait for 5 seconds > set 0% > wait for 5 seconds.
- ▶ Set 60% > wait for 5 seconds > set 0% > wait for 5 seconds..
- ▶ If the device still detects bubbles in the pipe, then contact Bürkert.
- ▶ Select **Controller** > **Set-point value source** > **Automatic**

MFC with proportional valve

- ▶ Make sure that the device is filled with medium.
- ▶ Connect the device to the Bürkert Communicator software. Refer to [Connect to the Bürkert Communicator \[▶ 67\]](#)
- ▶ Select the device.



WARNING!

Risk of injury from flowing medium.

While the procedure is running, the mass flow rate value can be higher than the nominal flow rate value.

- ▶ Before running the procedure, make sure that no danger can occur if the mass flow rate value increases.
- ▶ Select **Controller** > **Set-point value source** > Choose **Open-loop control mode**
 - ✓ The status indicator is orange.
 - ✓ A check-function event is generated.
- ▶ Select **Actuator** > **Actuating variable**

- ▶ Do the following sequence: set 100% > wait for 5 seconds > set 0% > wait for 5 seconds.
- ▶ Repeat the previous sequence 2 times.
- ▶ If the device still detects bubbles in the pipe, then contact Bürkert.
- ▶ Select **Controller** > **Set-point value source** > **Automatic**

8.4.5 Configure the actuator

MFC for modular actuator

- ▶ Connect the device to the Bürkert Communicator software. Refer to [Connect to the Bürkert Communicator \[▶ 67\]](#)
- ▶ Select the device.
- ▶ Select **Actuator** > **Parameter** > **Start-Up Wizard**
 - ✓ The status indicator is orange.
 - ✓ A check-function event is generated.
- ▶ Follow the instructions of the displayed wizard.

8.5 Set the CANopen communication or the bÜS communication

bÜS / CANopen variant

To set the operating mode of the digital communication, do the following:

- ▶ Connect the device to the Bürkert Communicator software. Refer to [Connect to the Bürkert Communicator \[▶ 67\]](#)
- ▶ Select the device.
- ▶ Select **General settings** > **Parameters** > **bÜS** > **Advanced** > **Bus mode**
- ▶ Select the operating mode of the digital communication.
- ▶ Restart the device.
- ✓ The operating mode of the fieldbus is changed.
- ✓ If the operating mode of the fieldbus is bÜS, then the **CANopen status** is set to **Operational** and the PDOs are sent to bÜS.
- ✓ If the operating mode of the fieldbus is CANopen, then the **CANopen status** is set to **Pre-Op** until the CANopen network master switches the device to **Operational**.

8.6 Increase the data transmission speed

bÜS / CANopen variant

If the data transmission speed is increased, then the device provides more cyclic process-data.

For example, the actual value of the mass flow rate is available once every 100 ms by default. If the data transmission-speed is increased, then the actual value of the mass flow rate is available once every 10 ms.

- ▶ If the data transmission-speed is active simultaneously on several devices in the network, then make sure that the bus load does not exceed 50%.

To increase the data transmission-speed, do the following:

- ▶ Energise the bus network.
- ▶ Connect the device to the Bürkert Communicator software. Refer to [Connect to the Bürkert Communicator \[▶ 67\]](#)
- ▶ Move the PC mouse over the bÜS-stick symbol in the list of devices. If the bus load is higher than 45%, then do not increase the data transmission-speed.
- ▶ If the bus load is less than or equal to 45%, then the data transmission-speed can be increased. Do the following procedure:
 - ▶ Select the device.
 - ▶ Select **General settings** > **Parameter** > **PDO Configuration**.
 - ▶ To increase the data transmission-speed, change the inhibit time of the PDO to the desired value (min. 10 ms). Confirm the entry with **Apply and Save**.
 - ✓ The data transmission-speed is increased.
 - ▶ To go back to the default data transmission-speed, click **Reset to default values**.

8.7 Operation modes

MFC

When energising the device for the first time, the device enters a short initialisation phase and then switches to the normal operation mode. Refer to [Normal operation mode \[▶ 74\]](#)

- ▶ To change the operation mode, change the source for the set-point values. Refer to [Select the source that gives the set-point value \[▶ 78\]](#)

The operation mode is kept after a device restart, except when the device performs the function **Analyze system**.

8.8 Normal operation mode

MFC

The normal operation mode is active when energising the device for the first time.

MFC with pump

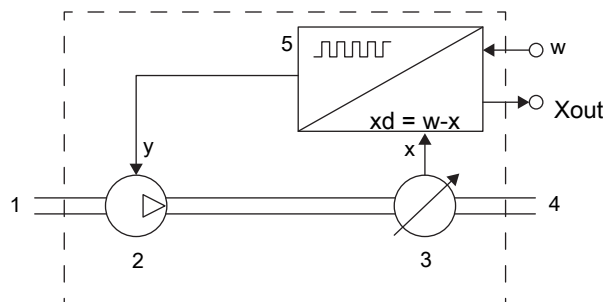

Fig. 36: Function diagram of the MFC with pump

1 Medium inlet	2 Pump
3 Sensor	4 Medium outlet
5 Electronics	x measured value of the mass flow rate
y set-point position of the pump	w set-point value of the mass flow rate

The sensor measures the mass flow rate and compares the measured value x with the set-point value w . The device calculates the set-point position value y of the actuator.

- The set-point position value y determines the speed of the pump. For example, if the setpoint position value y is equal to 10%, then the speed of the pump is 10%.

The transmission means of the set-point value w and the measured value of the flow rate depends on the device.

- ▶ If the operating conditions have changed, then optimise the closed-loop control parameters. Refer to [Optimise the closed-loop control parameters \[▶ 77\]](#)
- ▶ To change the operation mode, change the source for the set-point value. Refer to [Select the source that gives the set-point value \[▶ 78\]](#)

MFC with proportional valve



If the valve seat seal is made of a hard material such as PCTFE, then the control valve may not be tight.

Valves with a seat size of 0.05 mm or 0.1 mm have a seat seal made of a hard material.

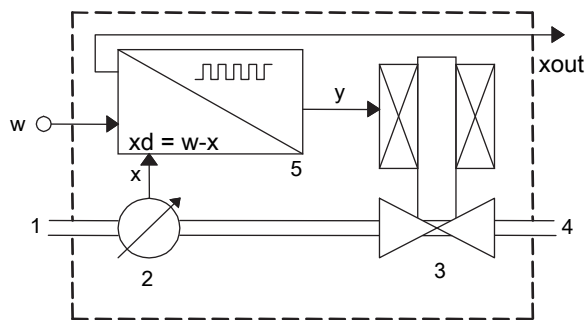

Fig. 37: Function diagram of the MFC with control valve

1 Medium inlet	2 Sensor
3 Control valve	4 Medium outlet
5 Electronics	x measured value of the mass flow rate
y set-point position of the valve	w set-point value of the mass flow rate

The sensor measures the mass flow rate and compares the measured value x with the set-point value w . The device calculates the set-point position value y of the actuator.

- The set-point position value y determines the opening of the control valve. For example, if the set-point position value y is equal to 10%, then the opening of the control valve is 10%.

The transmission means of the set-point value w and the measured value of the flow rate depends on the device.

- ▶ If the operating conditions have changed, then optimise the closed-loop control parameters. Refer to [Optimise the closed-loop control parameters \[▶ 77\]](#)
- ▶ To change the operation mode, change the source for the set-point value. Refer to [Select the source that gives the set-point value \[▶ 78\]](#)

8.8.1 Analogue variant

If the device detects that the pipe is empty, then the device cannot regulate.

On a MFC with pump, fill the pipe. Refer to [Fill the pipe without damaging the pump \[▶ 66\]](#)

After applying the operating voltage, the device enters a short initialisation phase and then switches to the normal operation mode. The normal operation mode of a variant Analogue is the **Analog setpoint** operation mode.

- The set-point value w is transmitted over the set-point analogue input according to the ranges in the following table.
- The measured value of the flow rate is transmitted over the analogue output according to the ranges in the following table.

Analogue output range	Minimum value of the input ranges and output ranges	Maximum value of the input ranges and output ranges
4...20 mA	4 mA, $w = 0\%$	20 mA, $w = 100\%$
0...20 mA	0 mA, $w = 0\%$	20 mA, $w = 100\%$
0...5 V \equiv	0 V, $w = 0\%$	5 V, $w = 100\%$
0...10 V \equiv	0 V, $w = 0\%$	10 V, $w = 100\%$

Tab. 17: Analogue-input ranges and analogue-output ranges

8.8.2 Industrial Ethernet variant

After applying the operating voltage, the device enters a short initialisation phase and then switches to the **Automatic** operation mode.

- ▶ To change the control mode, i. e. to change the source for the set-point values. Refer to [Select the source that gives the set-point value \[▶ 78\]](#)
- ▶ To change the control parameters, use the Bürkert Communicator.

8.8.3 bÜS /CANopen variant

If the device detects that the pipe is empty, then the device cannot regulate.

On a MFC with pump, fill the pipe. Refer to [Fill the pipe without damaging the pump \[▶ 66\]](#)

After applying the operating voltage, the device enters a short initialisation phase and switches to the normal operation mode. The normal operation mode of a variant bÜS/CANopen is the **Automatic** operation mode. The set-point value is set via the fieldbus.

8.9 Optimise the closed-loop control parameters

MFC

The closed-loop control parameters of the device can be optimised for the current operating conditions with a function that is called Autotune.

- Run the Autotune function when the device is started for the first time.
- If the operating conditions have changed, then run the Autotune function.

If the device detects that the pipe is empty, then the Autotune function cannot be started.

On a MFC with pump, fill the pipe. Refer to [Fill the pipe without damaging the pump \[▶ 66\]](#)

When the Autotune is running:

- ▶ Do not interrupt the power supply to the device.

- ▶ Keep the supply pressure constant.



WARNING!

Risk of injury from flowing medium.

While the Autotune function is running, the mass flow rate value can be higher than the nominal flow rate value.

- ▶ Before running the Autotune function, make sure that no danger can occur if the mass flow rate value increases.
- ▶ Trigger the Autotune function with one of the following means:
 - ▶ over the fieldbus (variant büS/CANopen),
 - ▶ over the fieldbus (variant Industrial Ethernet)
 - ▶ over the digital input (variant Analogue),
 - ▶ with the Bürkert Communicator. Refer to [Connect to the Bürkert Communicator \[▶ 67\]](#)
- ✓ The Autotune runs and the status indicator is orange.
- ✓ The device temporarily stops regulating the flow rate in the pipe.
- ✓ When the function is completed, the device returns to its previous operating mode.
- ✓ If the function is completed successfully, then the optimised closed-loop control parameters are transferred to the hard memory of the device.

8.10 Select the source that gives the set-point value

MFC

The process set-point value can be set by different sources. It is possible to select which source is active at a time. The source for the set-point value can be changed during operation.

If the source for the set-point value is changed, then the operation mode of the device is changed.

To change the source for the set-point value, change the setting of the parameter **Set-point value source** with the Bürkert Communicator. Refer to [Connect to the Bürkert Communicator \[▶ 67\]](#)



The setting of the parameter **Set-point value source** is kept after a restart, except when the device performs the function **Analyze system** or the set-point value source was set to manual set-point.

büS / CANopen variant | Industrial Ethernet variant

It is possible to alternatively change the related object. Refer to the file Device Description File.

- ▶ Access the page [Type 8756](#)
- ▶ Scroll down to **Downloads** > **Software**

Possible choices for the parameter **Set-point value source**

Variant büS/CANopen: Automatic	The set-point value is set via the fieldbus.
Variant Analogue: Analog set-point value source	The setpoint value is set via the analogue input.
Variant Industrial Ethernet: Automatic	The set-point value is set via the fieldbus. If different fieldbus participants simultaneously specify a set-point value for the device, it is always the last set value that is used.
Manual set-point value	To manually give in a set-point value for testing purposes or to make sure that the set-point value is not overwritten by other fieldbus participants.
Stored setpoint	To use a fixed set-point value (w). If the device is restarted, then the fixed set-point value remains active. Refer to Normal operation mode [▶ 74]
Open-loop control mode	To directly set the set-point position (y) to the actuator. The value that is given in the menu Actuator > Parameter > Actuating variable is the setpoint position (y) that is used. A restart of the device sets the set-point position (y) to zero. Refer to Normal operation mode [▶ 74]
Analyze system	The device operates in the normal operation mode, but according to a predefined chronological sequence with set-point values. Use the resulting diagram in combination with the graphical representation of process values to analyse the system with the Bürkert Communicator.

8.11 Set-point values without communication

Industrial Ethernet variant | büS / CANopen variant

The function makes it possible to specify the set-point values of the device even if the communication with the external set-point value provider (for example a PLC) is broken. If the function is used, then the set-point is kept constant.



By using the function, the medium can continue to flow even if the communication is broken.

▶ Make sure the process is safe when the function is used.

- ▶ To use the function, refer to the file Device Description File.
- ▶ Access the page [Type 8756](#)
- ▶ Scroll down to **Downloads > Software**
- ▶ The configuration is available under **Controller > Parameter > Setpoint > Advanced settings > Connection abort behaviour**

8.12 Automatic flushing

Can be activated if needed. This function will flush the pipes for a defined period of time after the device was idle for a set period of time.

- ▶ To activate the function, go to: **Controller** > **Parameter** > **Automatic flushing** > **Enable automatic flushing** > **Yes**.
- ▶ See the predefined values and change them.

8.13 Changing between büS and CANopen mode

büS / CANopen variant

To select the different digital communication modes (**büS** or **CANopen**), use the software Bürkert communicator.

- ▶ Connect the device to the Bürkert Communicator software. Refer to [Connect to the Bürkert Communicator \[▶ 67\]](#)
- ▶ Select the device.
- ▶ Select **General settings** > **Parameter** > **büS** > **Advanced** > **Bus mode**
- ▶ Select the operating mode of the digital communication.
- ▶ Restart the device.
- ✓ The operating mode of the fieldbus is changed.
- ✓ If the operating mode of the fieldbus is büS, the **CANopen status** is set to **Operational** and the PDO's are sent to büS.
- ✓ If the operating mode of the fieldbus is CANopen, the **CANopen status** is set to **Pre-Op** until the CANopen network master switches the device to **Operational**.

9 Maintenance

If the device is operated according to the Operating instructions, then the device is maintenance-free.



Risk of injury or material damage when working on the device or system.

- ▶ Read and observe the chapter [Safety \[▶ 8\]](#) before working on the device or system.

9.1 Replace the memory card

- ▶ De-energise the device.
- ▶ With a TX8 screwdriver loosen the screws of the cover. Remove the cover.

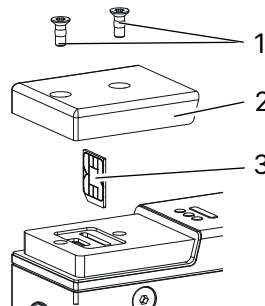

Fig. 38: Insertion direction of the memory card

1 Screws	2 Cover
3 Memory card: make sure the insertion direction is correct.	

- ▶ Remove the old memory card from its slot.
- ▶ Pay attention to the insertion direction of the memory card.

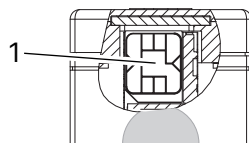

Fig. 39: Cross-sectional drawing

1 Inserted memory card

- ▶ With a TX8 screwdriver, screw the cover to a torque of 1.2 N·m (0.9 lbf·ft).
- ▶ Restart the device to write the data on the new memory card. Possible problems related to the memory card are given in [Troubleshooting \[▶ 83\]](#)

büS / CANopen variant

The büS/CANopen variant supports the config-client if no memory card is used.

- ▶ Activate this functionality in the Bürkert communicator under **General settings > Parameter > Act as a configuration client > Yes.**

For detailed information, refer to the "Software manual | Central configuration management".

- ▶ Access the page [Type 8756](#)
- ▶ Scroll down to **Downloads > User Manuals**

9.2 Sterilising the device with hot water

MFM



The sterilisation procedure is only valid for an MFM with seals in metal or PCTFE.

- ▶ De-energise the device.
- ▶ Let water at a temperature of 90°C flow through the device for maximum 30 minutes.
- ▶ Let the device cool down for 2 hours.
- ▶ Commission the device.

9.3 Sterilising the device with steam

MFM



The sterilisation procedure is only valid for an MFM with seals in FFKM.

- ▶ De-energise the device.
- ▶ Let steam at a temperature of 120°C flow through the device for maximum 30 minutes.
- ▶ Let the device cool down for 2 hours.
- ▶ Commission the device.

10 Troubleshooting

10.1 Status indicator is red

Cause	Solution
The supply voltage is out of the error range. The device can be damaged.	<ul style="list-style-type: none"> ▶ Operate the device within the specifications. <p>If the status indicator does not change, then send the device back to Bürkert.</p>
The sensor, the internal memory or the device is defective.	<p>Maintenance is needed.</p> <ul style="list-style-type: none"> ▶ Contact the manufacturer.
Industrial Ethernet variant	
No proper connection to the PLC.	<ul style="list-style-type: none"> ▶ Check the wiring. ▶ Check the status of the PLC.
EtherCAT variant	
	<ul style="list-style-type: none"> ▶ If the EtherCAT protocol is used, make sure the incoming cable (reception from the PLC) is inserted in the ETH1 port and the outgoing cable is inserted in the ETH2 port.
büS / CANopen variant	
büS error or CANopen-bus error, for example a short circuit.	<ul style="list-style-type: none"> ▶ Check the wiring.
büS / CANopen variant	
The device is connected to büS, but cannot find any fieldbus participants.	<ul style="list-style-type: none"> ▶ Check the wiring. ▶ Operate the device with other fieldbus participants.
büS / CANopen variant	
The device is connected to büS, but does not find the process value to be processed.	<ul style="list-style-type: none"> ▶ Make sure that the process value is correctly allocated. ▶ Check the assigned büS participant that is defective. ▶ Make sure that the assigned büS participant provides the cyclic data.
MFC	
Incorrect Autotune or Autotune aborted. After a restart of the device, the error will be reset.	<ul style="list-style-type: none"> ▶ Make sure that the medium flows through the device. ▶ Check the Q_{nom} of the device. ▶ Start the Autotune again. <p>After a restart of the device, the error will be reset.</p>

10.2 Status indicator is orange

Cause	Solution
A calibration procedure is in progress.	▶ Wait until the procedure is completed.
büS / CANopen variant	
The device is connected to büS and searches assigned fieldbus participant.	▶ Wait until the device has found assigned fieldbus participants.
büS / CANopen variant	
The device is connected to büS and is configured manually, but has no address.	▶ Wait up to one minute until the device assigns its address.
PROFINET variant	
PLC is in Stop mode.	▶ Activate the PLC.
MFC	
The Autotune is in progress.	▶ Wait until the procedure is completed.
MFC	
The operation mode of the device is set to Open-loop control mode , Manual set-point value or Analyze system .	Refer to Select the source that gives the set-point value [▶ 78]

10.3 Status indicator is yellow



The yellow state is displayed for about 15 seconds after electrical power up. The device needs this time to reach the normal operation mode. After this initialisation the device will change to the green state.

Cause	Solution
One of the following values is out of specification. The sensor or the device can be damaged. <ul style="list-style-type: none"> the medium temperature the device temperature the supply voltage 	▶ Operate the device within the specifications. If the status indicator does not change, then send the device back to Bürkert.
The device has detected that the pipe is empty.	▶ Vent the pipe. ▶ Fill the pipe completely with medium. Refer to Commissioning [▶ 65]

Cause	Solution
The device has detected bubbles in the liquid.	MFM ▶ Increase the medium pressure.
	MFM ▶ Do not use a medium that is saturated with air.
	MFM ▶ Observe the installation procedure.
	MFC ▶ Flush bubbles from the pipe. Refer to Flush bubbles from the pipe [▶ 72]
büS / CANopen variant	
Other fieldbus participants use the same node ID.	▶ Assign an individual node ID to each fieldbus participant.
Industrial Ethernet variant	
A change of the Ethernet protocol is in progress.	▶ Wait until the procedure is completed.
MFC	
The set-point position for the actuator has (almost) reached 100%. The set-point value cannot be reached.	▶ Increase the inlet pressure or decrease the output pressure.
	▶ Make sure that the medium viscosity is in the permitted range. Refer to Technical data [▶ 23]
	▶ If the pressure drop in the pipe is too high, then reduce the pressure drop.
	▶ If the filters installed in the pipe are dirty, then clean the filters.

10.4 Status indicator is blue

Cause	Solution
Error in the internal memory.	Maintenance is needed. ▶ Contact the manufacturer.

10.5 Status indicator is off

Cause	Solution
The device is not energised.	<ul style="list-style-type: none"> ▶ Check the wiring. ▶ Make sure that the voltage supply is 24 V $\overline{=}$. ▶ Make sure that the power supply source is working properly.

10.6 Status indicator flashes

Cause	Solution
The power supply source is not working properly.	<ul style="list-style-type: none"> ▶ Make sure that the power supply source is working properly. <p>After max. 10 seconds, the device automatically returns to the previous status.</p>
The device is selected in the Bürkert Communicator.	<p>After max. 10 seconds, the device automatically returns to the previous status.</p>

10.7 Status indicator goes out periodically

Cause	Solution
The power supply is intermittently dropping and the device restarts.	<ul style="list-style-type: none"> ▶ Use a power supply with sufficient power output.
The voltage drop in the connecting cable is too high.	<ul style="list-style-type: none"> ▶ Increase the cross-section of the cable and reduce the cable length.

10.8 Replacement device adopts none of the values from the defective device

Cause	Solution
The article number of the replacement device is different from the article number of the defective device.	<ul style="list-style-type: none"> ▶ Use a replacement device that has the same article number than the defective device. <p>Values can only be transferred between devices with the same article numbers.</p>
The memory card is defective. The device could not write any values to the memory card.	<ul style="list-style-type: none"> ▶ Replace the memory card. <p>Refer to Replace the memory card [▶ 81].</p>

10.9 Replacement device does not adopt all of the values from the defective device

Cause	Solution
The device description of the replacement device is different from the device structure of the defective device. Only the existing values of the defective device can be adopted by the replacement device.	<ul style="list-style-type: none"> ▶ Use the Bürkert Communicator to configure the new values of the replacement device.

10.10 No mass flow rate

Cause	Solution
The pipes are too large or not yet fully vented.	<ul style="list-style-type: none"> ▶ Vent the pipe. ▶ Change the pipe diameter.
The flow-rate value is below the cut-off limit.	<ul style="list-style-type: none"> ▶ If the cut-off limit is too high, decrease the value of the cut-off limit. <p>Refer to Cut-off [▶ 71].</p>

MFC

The device is not in the normal operation mode, refer to [Operation modes \[▶ 74\]](#).

The device is possibly running one of the functions described in [Select the source that gives the set-point value \[▶ 78\]](#)

- ▶ If the device is not running one of the functions described in [Select the source that gives the set-point value \[▶ 78\]](#), then check the other possible causes of the problem.

MFC

The set-point value is lower than the zero-point shut-off limit.

- ▶ Increase the set-point value until it is higher than 2% of the nominal flow rate.

10.11 Unstable measured value

Cause	Solution
Functional earth (FE) is not connected properly.	<ul style="list-style-type: none"> ▶ To connect the functional earth, use a green-and-yellow cable that is as short as possible. <p>the cable cross-section must be at least equal to the cross section of the power-supply cable. Refer to Connect the functional earth [▶ 63]</p>

MFC

The residual ripple on the voltage supply is too high.

- ▶ Use a supply voltage that conforms to the technical data given in [Technical data \[▶ 23\]](#)

Cause	Solution
MFC The device must compensate for irregularities in an unstable pressure supply caused, for example, by pumps.	<ul style="list-style-type: none"> ▶ Install a suitable pressure regulator in front of the device. ▶ Install a buffer tank to absorb the pressure fluctuations.
MFC The controller is unstable.	<ul style="list-style-type: none"> ▶ Run the Autotune function to adapt to the operating conditions.
MFC Appearance of noise in the flow rate signal.	<ul style="list-style-type: none"> ▶ Run the Autotune function to adapt to the operating conditions. ▶ Use degassed medium. ▶ Mount the device in the recommended installation position. <p>Refer to Installation procedure [▶ 46]</p> <ul style="list-style-type: none"> ▶ Reduce the inlet pressure. ▶ Contact the manufacturer.

10.12 Set-point value at 0 %, but medium still flows

Cause	Solution
MFC for modular actuator MFC with proportional valve The connected actuator is a proportional valve and the operating pressure is above the tight sealing pressure of the proportional valve.	<ul style="list-style-type: none"> ▶ Reduce the operating pressure. ▶ To eliminate the defect, return the device to the manufacturer.
MFC for modular actuator MFC with pump The connected actuator is a pump and there is pressure upstream the pump. The pressure makes the medium flow. Pressure can be due to an incorrect position of the medium container.	<ul style="list-style-type: none"> ▶ Install the medium container in such a way that no pressure is generated upstream the pump.
MFC Analogue The operating mode of the device is set to Open-loop control mode , and the actuator is open because the digital input triggers the opening of the actuator.	<ul style="list-style-type: none"> ▶ Set the device to the normal operating mode. <p>Refer to Normal operating mode (MFC) and to Select the source that gives the set-point value [▶ 78].</p> <ul style="list-style-type: none"> ▶ Check the operation of the digital input. <p>Refer to Digital input [▶ 58]</p>

10.13 Set-point value at 0 %, no mass flow, but a non-zero mass flow rate is measured

Cause	Solution
MFC	
The installation position of the device is incorrect.	<ul style="list-style-type: none"> ▶ Install the device as recommended in Medium connection [▶ 46] ▶ Run the Autotune function to adapt to the operating conditions.
MFC	
There are bubbles in the sensor. The relay output of an Analogue variant can be parametered to switch when there are bubbles in the sensor.	<ul style="list-style-type: none"> ▶ Flush the device to remove the bubbles.

10.14 Set-point value is not reached

Cause	Solution
MFC	
The mesh filter is clogged.	<ul style="list-style-type: none"> ▶ Clean or replace the mesh filter. ▶ Run the Autotune function to adapt to the operating conditions.
MFC with pump MFC with proportional valve	
The outlet pressure is too high.	<ul style="list-style-type: none"> ▶ Make sure that the pipe diameters and the pipe lengths are adapted. ▶ If the medium connection pipes after the device are dirty, then clean them.
MFC with pump	
The suction pressure of the pump is too low. The distance between the MFC and the medium container is too high. The position of the medium container is too low with regards to the MFC.	<ul style="list-style-type: none"> ▶ Place the medium container so that the required suction pressure is lower than 200 mbar.
MFC with proportional valve	
The inlet pressure is too low.	<ul style="list-style-type: none"> ▶ Increase the inlet pressure to the calibration pressure value. ▶ Make sure that the pipe diameters and the pipe lengths are adapted.

Cause	Solution
<p>MFC for modular actuator</p> <p>The connected actuator is a proportional valve and the inlet pressure is too low.</p>	<ul style="list-style-type: none"> ▶ Make sure that the pipe diameters and the pipe lengths are adapted.
<p>MFC for modular actuator</p> <p>The connected actuator is a proportional valve and the outlet pressure is too high.</p>	<ul style="list-style-type: none"> ▶ Make sure that the pipe diameters and the pipe lengths are adapted.
<p>MFC for modular actuator</p> <p>The connected actuator is a pump and the suction pressure of the pump is too low. The distance between the MFC and the medium container is too high. The position of the medium container is too low with regards to the MFC.</p>	<ul style="list-style-type: none"> ▶ Place the medium container so that the required suction pressure is lower than 200 mbar.

10.15 Outgassing or bubble formation at the device outlet

Cause	Solution
<p>MFC with pump</p> <p>The pressurized liquid has a high gas solubility.</p>	<ul style="list-style-type: none"> ▶ If possible, reduce the liquid pressure. ▶ Pressurize with a gas that has a lower solubility in the medium.
<p>MFC with proportional valve MFC for modular actuator</p> <p>The pressurized liquid has a high gas solubility or outgassing occurs due to the pressure drop across the control valve.</p>	<ul style="list-style-type: none"> ▶ If possible, reduce the liquid pressure. ▶ Pressurize with a gas that has a lower solubility in the medium. ▶ Pump the unpressurized medium.

10.16 Network status indicator

LED indicator	Meaning	Action
Link/Act-LED (green) fast blinking	Connection to the parent protocol layer is established.	-
Link/Act-LED (green) slow blinking (directly after restart)	Connection to the protocol layer is searched.	-
Link/Act-LED (green) slow blinking (20 s after restart)	No connection to the parent protocol layer.	▶ Check the cable.
Link/Act-LED (green) is OFF.	No connection to the network.	▶ Check the cable.
Link-LED (yellow) is ON	Connection to the network is established.	-
Link LED (yellow) is not lit	Not connected to network.	▶ Check cable.

Tab. 18: Meaning of the LED indicator

11 Uninstallation

11.1 Dismantling

- ▶ Relieve the medium pressure in the installation.
- ▶ Flush the device with distilled water.
- ▶ Relieve the flushing medium pressure in the installation.
- ▶ De-energise the device.
- ▶ Remove the mating female connectors and the mating male connectors.
- ▶ Disconnect the medium connections.

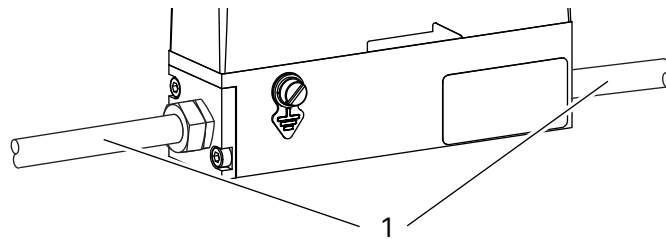

Fig. 40: Medium connections, for example internal-threaded connections

1 Medium connections

- ▶ Remove the device.

12 Spare parts and accessories



Risk of injury and/or damage due to incorrect parts.

- ▶ Use only original accessories and original spare parts from Bürkert.



Order the parts directly on our [eShop](#).

12.1 Electrical accessories

- ▶ For further accessories, refer to the data sheet.

Analogue variant

USB-büS-interface set, without power supply	772551
Straight 5-pin M12 female connector	772416
Straight 5-pin M12 male connector	772417
Bent 5-pin M12 female connector	772418
Memory card	on request
Connection cable with M12 male connector (A-coded) and free cable end, 5 m	566923
Connection cable with M12 male connector (A-coded) and free cable end, 10 m	571393
Connection cable with M12 female connector (A-coded) and free cable end, 5 m	560365
Connection cable with M12 female connector (A-coded) and free cable end, 10 m	563108
Bent 8-pin M12 male connector	775070

Industrial Ethernet variant

USB-büS-interface set, without power supply	772551
Straight 5-pin M12 female connector	772416
Bent 5-pin M12 female connector	772418
Memory card	on request
Connection cable with M12 female connector (A-coded) and free cable end, 5 m	560365
Connection cable with M12 female connector (A-coded) and free cable end, 10 m	563108
Bent 8-pin M12 male connector	775070
Adapter M8 - M12 D coded	576314

Type 8756

Spare parts and accessories

büS / CANopen variant

USB-büS-interface set, including power supply	772426
Straight 5-pin M12 female connector	772416
Bent 5-pin M12 female connector	772418
Y junction	772420
Y junction for connecting 2 separately energised segments of a büS network	772421
5-pin M12 male connector with 120-Ohm termination resistor	772424
5-pin M12 female connector with 120-Ohm termination resistor	772425
Memory card	on request
büS extension cable with 5-pin M12 connectors, 0.1 m	772492
büS extension cable with 5-pin M12 connectors, 0.2 m	772402
büS extension cable with 5-pin M12 connectors, 0.5 m	772403
büS extension cable with 5-pin M12 connectors, 1 m	772404
büS extension cable with 5-pin M12 connectors, 3 m	772405
Bent 8-pin M12 male connector	775070

12.2 Mounting accessories

Alloy C22 compression fitting	907 203
-------------------------------	---------

12.3 Additional software

Bürkert Communicator software	Download from country.burkert.com
büS LabView-driver	Download from country.burkert.com
Variant büS /CANopen and Industrial Ethernet EDS file	Download from country.burkert.com

13 Logistics

13.1 Transport and storage

- ▶ Protect the device against moisture and dirt in the original packaging during transportation and storage.
- ▶ Avoid UV radiation and direct sunlight.
- ▶ Protect connections, if present, from damage with protective caps.
- ▶ Observe the permitted storage temperature.
- ▶ Remove cables, connectors, external filters and installation equipment.
- ▶ Clean and vent contaminated devices.

13.2 Return



No work or tests will be carried out on the device until a valid Contamination Declaration has been received.

- ▶ To return a used device to Bürkert, contact the Bürkert sales office. A return number is required.

13.3 Disposal

Environmentally friendly disposal



- ▶ Follow national regulations regarding disposal and the environment.
- ▶ Collect electrical and electronic devices separately and dispose of them as special waste.

Further information at country.burkert.com