

# Type 8746

Mass flow controller (MFC)/mass flow meter (MFM) for gases



## Operating Instructions

We reserve the right to make technical changes without notice.

© Bürkert SAS 2015-2026

Technical documentation 2603/09\_GBen\_00810417\_520721547\_1005184523 / Original EN

# Table of contents

<b>1</b>	<b>About this document</b>	<b>6</b>
1.1	Symbols	6
1.2	Terms and abbreviations	7
1.3	Manufacturer	7
<b>2</b>	<b>Safety</b>	<b>8</b>
2.1	Intended use	8
2.2	Safety instructions	8
<b>3</b>	<b>Product description</b>	<b>11</b>
3.1	Product overview	11
3.2	Product identification	13
3.2.1	Type label	13
3.2.2	Calibration label	13
3.2.3	Conformity marking	14
3.2.4	Symbols and markings on device	14
3.3	Display elements	14
3.3.1	Status indicator	14
3.3.2	NAMUR mode	15
3.3.3	Network status indicator	15
3.3.4	Communication indicator	16
3.4	Functionality	16
3.4.1	Service-büS interface	16
3.4.2	Control valve	16
3.4.3	Memory card	17
<b>4</b>	<b>Technical data</b>	<b>18</b>
4.1	Standards and directives	18
4.2	Operating conditions	18
4.3	Medium data	19
4.3.1	Pressure loss	21
4.4	Electrical data	23
4.5	Communication	26
4.5.1	Industrial Ethernet: EtherCAT	26
4.5.2	Industrial Ethernet: EtherNet/IP	27
4.5.3	Industrial Ethernet: Modbus TCP	27
4.5.4	Industrial Ethernet: PROFINET IO	27
4.6	Mechanical data	28
<b>5</b>	<b>Medium connection</b>	<b>29</b>
5.1	Possible medium connections	29
5.2	Installation procedure	29
5.2.1	G1/8"-internal-threaded connections	29
5.2.2	NPT1/8"-internal-threaded connections	29
5.2.3	Flange connections	30
5.2.4	Connections with external-threaded vacuum fittings	30
5.2.5	Connections with external-threaded compression fittings	30
5.2.6	Tri-clamp connections	30
<b>6</b>	<b>Electrical connection</b>	<b>31</b>

6.1	Additional documentation	31
6.2	Wire the variant bÜS /CANopen	31
6.2.1	With bÜS extension cables from Bürkert	31
6.2.2	With bÜS cables from Bürkert	31
6.2.3	With CANopen cables	32
6.3	Wire the variant Analogue	33
6.3.1	Digital input	35
6.3.2	Relay output	37
6.4	Wire the variant Industrial Ethernet	38
6.5	Change the network parameters	39
6.5.1	Over the product web server	40
6.5.2	Over the Bürkert Communicator software	40
6.6	Wire the variant Profibus	41
6.7	Change the Profibus network parameters	42
6.7.1	Over the Bürkert Communicator software	42
6.8	Connect the functional earth	43
<b>7</b>	<b>Commissioning</b>	<b>44</b>
7.1	Commissioning procedure	44
<b>8</b>	<b>Configuration with Bürkert Communicator</b>	<b>45</b>
8.1	Setting tools	45
8.2	Connect to the Bürkert Communicator	45
8.3	Setting the Industrial Ethernet address	47
8.4	Functions	47
8.4.1	Shut-Off threshold for the valve	47
8.4.2	Cut-Off threshold for actual flow	47
8.4.3	Flush mode	48
8.5	User-defined adjustment	48
8.6	Zero point adjustment	48
8.7	Set-point value sources and operation modes	48
8.8	Increase the data transmission speed	49
8.9	Operation modes	50
8.10	Normal operation mode	50
8.10.1	Analogue variant	51
8.10.2	Industrial Ethernet variant	52
8.10.3	bÜS /CANopen variant	52
8.11	Optimise the closed-loop control parameters	52
8.12	Select the source that gives the set-point value	53
8.13	Set-point values without communication	54
8.14	Changing between bÜS and CANopen mode	55
<b>9</b>	<b>Maintenance</b>	<b>56</b>
9.1	Service tasks and intervals	56
9.2	Inspect and clean the stainless steel mesh-filter	56
9.3	Calibration	57
9.4	Replace the memory card	57
<b>10</b>	<b>Troubleshooting</b>	<b>60</b>
10.1	Status indicator is red	60
10.2	Status indicator is orange	61
10.3	Status indicator is yellow	61

10.4	Status indicator is blue	62
10.5	Status indicator is off	62
10.6	Status indicator goes out periodically	62
10.7	Replacement device adopts none of the values from the defective device	62
10.8	Replacement device does not adopt all of the values from the defective device	63
10.9	No mass flow rate	63
10.10	Unstable measured value	64
10.11	Set-point value at 0 %, but medium still flows	64
10.12	Set-point value at 0 %, no mass flow, but a non-zero mass flow rate is measured	65
10.13	Set-point value is not reached	65
10.14	Network status indicator	66
<b>11</b>	<b>Uninstallation</b>	<b>67</b>
11.1	Dismantling	67
<b>12</b>	<b>Spare parts and accessories</b>	<b>68</b>
12.1	Electrical accessories	68
12.2	Compression fittings for a device with G-internal-threaded connections	70
12.3	Additional software	70
<b>13</b>	<b>Logistics</b>	<b>71</b>
13.1	Transport and storage	71
13.2	Return	71
13.3	Disposal	71

# 1 About this document

The document is an important part of the product and guides the user to safe installation and operation. The information and instructions in this document are binding for the use of the product.

- ▶ Before using the product for the first time, read and observe the whole safety chapter.
- ▶ Before starting any work on the product, read and observe the respective sections of the document.
- ▶ Keep the document available for reference and give it to the next user.
- ▶ Contact the Bürkert sales office for any questions.



Further information concerning the product at [Products](#).

- ▶ Enter the article number from the type label in the search bar.

The illustrations in these instructions may vary depending on the product variant.

## 1.1 Symbols



### **DANGER!**

Warns of a danger that leads to death or serious injuries.



### **WARNING!**

Warns of a danger that can lead to death or serious injuries.



### **CAUTION!**

Warns of a danger that can lead to minor injuries.

### **NOTICE!**

Warns of property damage on the product or the installation.



Indicates important additional information, tips and recommendations.



Refers to information in this document or in other documents.

- ▶ Indicates a step to be carried out.

✓ Indicates a result.

**Menu** Indicates a software user-interface text.

## 1.2 Terms and abbreviations

The terms and abbreviations are used in this document to refer to following definitions.

Device	Type 8746
MFM	Mass flow meter
MFC	Mass flow controller
büS	Bürkert system bus, a communication bus developed by Bürkert and based on the CANopen protocol
bar, bar (g)	Unit for relative pressure
bar abs	Unit for absolute pressure
Ex area	Potentially explosive atmosphere
Ex approval	Approval for potentially explosive atmosphere

## 1.3 Manufacturer

Bürkert SAS

20, rue du Giessen

67220 TRIEMBACH-AU VAL

FRANCE

The contact addresses are available at [Contact](#).



Need more information or additional products?

► Explore the full range of products on our [eShop](#).

## 2 Safety

### 2.1 Intended use

The device MFM is designed to measure the mass flow rate of clean and dry gases.

The device MFC is designed to measure and regulate the mass flow rate of clean and dry gases.

The permitted media are listed in [Technical data \[▶ 18\]](#).

Prerequisites for safe and trouble-free operation are proper transport, storage, installation, commissioning, operation and maintenance.

The instructions are part of the device. The device is intended exclusively for use within the scope of these instructions. Uses of the device that are not described in these instructions, the contractual documents or the type label can lead to severe personal injury or death, damage to the device or property and dangers for the surrounding area or the environment.

- ▶ Only trained and qualified personnel may install, operate and maintain the device. See qualification of persons in [Safety instructions \[▶ 8\]](#)
- ▶ Use the device only in conjunction with third-party devices and components recommended and authorized by Bürkert.
- ▶ Use the device only when it is in perfect condition.
- ▶ Only use the device indoors.
- ▶ Only use devices that are approved for this type of potentially explosive atmosphere. These devices are labelled with the ATEX label on the type label. When using, always observe the details on the type label and the instructions for the potentially explosive atmosphere included in the scope of delivery for the device.
- ▶ Do not open the device.
- ▶ Do not use the device in high-vibration areas.

### 2.2 Safety instructions

#### Qualification of personnel working with the device

Improper use of the device can lead to serious personal injury or death. To avoid accidents when working with the device, the following minimum requirements must be met:

- ▶ Carry out work on the device within the scope of these instructions in a safety-compliant manner.
- ▶ Detect and avoid dangers when working on the device.
- ▶ Understand the instructions and implement the information contained therein accordingly.

#### Responsibility of the operator

The operator is responsible for observing the location-specific safety regulations, also in relation to personnel.

- ▶ Observe the general rules of technology.
- ▶ Install the device according to the regulations applicable in the respective country.
- ▶ The operator must make hazards arising from the location of the device avoidable by providing appropriate operating instructions.

## Electrostatically sensitive components and assemblies

The device contains electronic components that are susceptible to the effects of electrostatic discharging (ESD). Components that come into contact with electrostatically charged persons or objects are at risk. In the worst case scenario, these components will be destroyed immediately or fail after start-up.

- ▶ Meet the requirements specified by EN 61340-5-1 to minimise or avoid the possibility of damage caused by a sudden electrostatic discharge.
- ▶ Do not touch electronic components when the supply voltage is connected.

## Electric shock due to electrical components

Touching live parts can result in severe electric shock. This can lead to serious personal injury or death.

- ▶ Before working on the device or system, switch off the power supply. Secure it against reactivation.
- ▶ Observe any applicable accident prevention and safety regulations for electrical devices.

## Changes and other modifications, spare parts and accessories

Changes to the device, incorrect installation or use of non-approved devices or components create hazards that can lead to accidents and injuries.

- ▶ Do not make any changes to the device.
- ▶ Do not mechanically load the device.
- ▶ Observe the operating instructions of the device or component used.
- ▶ Only use the devices in conjunction with devices and components recommended or approved by Bürkert.

Spare parts and accessories that do not meet Bürkert's requirements may impair the operational safety of the device and cause accidents.

- ▶ To ensure operational safety, only use original parts from Bürkert.

## Operation only after proper transport, storage, installation, commissioning, or maintenance

Improper transport, storage, installation, commissioning, or maintenance jeopardises the operational safety of the device and can cause accidents. This can lead to serious personal injury or death.

- ▶ Observe all values and limits specified in these instructions to ensure the device's safety and functionality.
- ▶ Only carry out work described in these instructions.
- ▶ Only carry out work using suitable tools.
- ▶ All other work must be carried out by Bürkert only.

## Working on the device

Working on the device that has not been powered down, unauthorised switching on or uncontrolled start-up of the system can cause accidents. This can lead to serious personal injury or death.

- ▶ Only work on the device when it is not in use.
- ▶ Ensure that the device or system cannot be switched on unintentionally.

- ▶ Only start the process in a controlled manner following disruptions. Observe sequence:
  1. Apply supply voltage or pneumatic supply.
  2. Charge the device with medium.

### Technical limit values and media

Non-compliance with technical limit values or unsuitable media can damage the device and lead to leaks. This can cause accidents and seriously injure or kill people.

- ▶ Comply with limit values. See **Technical data** [▶ 18] and information on the type label.
- ▶ Only feed media into the media ports that are listed in the chapter **Technical data** [▶ 18].
- ▶ Observe the safety data sheet for the media used.

### Only use authorised devices in potentially explosive atmospheres

Devices that may be used in potentially explosive atmospheres are labelled with an Ex marking. Additional instructions with Ex labelling are included with these devices.

- ▶ Only use devices that are approved for use in a potentially explosive atmosphere.
- ▶ For use in potentially explosive atmospheres, observe the information on the device.
- ▶ For use in potentially explosive atmospheres, observe the additional instructions with Ex labelling.
- ▶ Do not use devices that do not have this Ex labelling and additional instructions in potentially explosive atmospheres under any circumstances.

### Medium under pressure

Medium under pressure can seriously injure people. In the event of overpressure or pressure surges, the device or lines can burst. Pneumatic lines that are defective or not securely fastened can come loose and swing around.

- ▶ Before working on the device or system, switch off the pressure. Vent or empty the lines.
- ▶ Adhere to the permitted pressure ranges of the medium.
- ▶ Comply with the permitted temperature ranges of the medium.

### Hot surfaces and fire hazard

The surface of the device can become hot with fast-switching actuators or with hot media.

- ▶ Wear suitable protective gloves.
- ▶ Keep highly flammable substances and media away from the device.

### 3 Product description

#### 3.1 Product overview

MFM Analogue | MFM Industrial Ethernet | MFM PROFIBUS

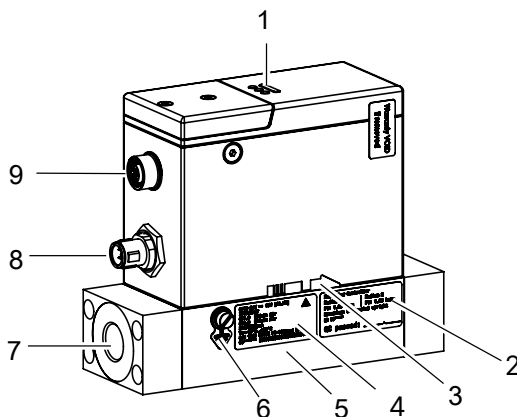

Fig. 1: Example of a variant MFM

1 Status indicator	2 Calibration label
3 Flow direction marking	4 Type label
5 Base block	6 Functional earth connection
7 Medium connection	8 Electrical connection
9 Electrical connection	

#### MFM büS/CANopen

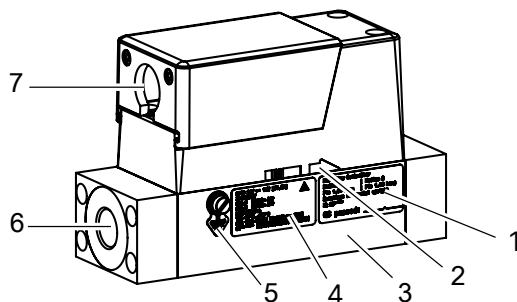

Fig. 2: Example of a variant MFM

1 Calibration label	2 Flow direction marking
3 Base block	4 Type label
5 Functional earth connection	6 Medium connection
7 Electrical connection	

MFC Analogue | MFC Industrial Ethernet | MFC PROFIBUS

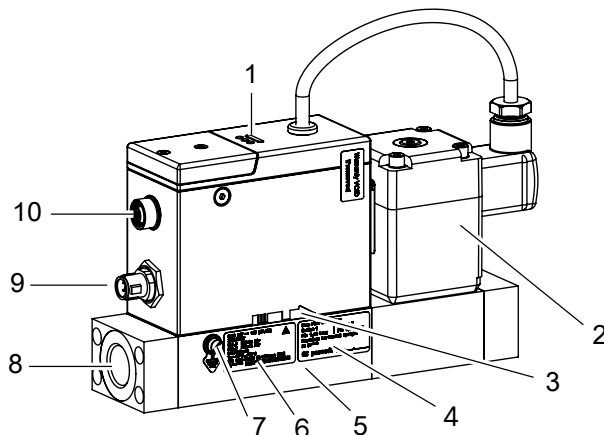

Fig. 3: Example of a variant MFC

1 Status indicator	2 Actuator
3 Flow direction marking	4 Calibration label
5 Base block	6 Type label
7 Functional earth connection	8 Medium connection
9 Electrical connection	10 Electrical connection

MFC büS/CANopen

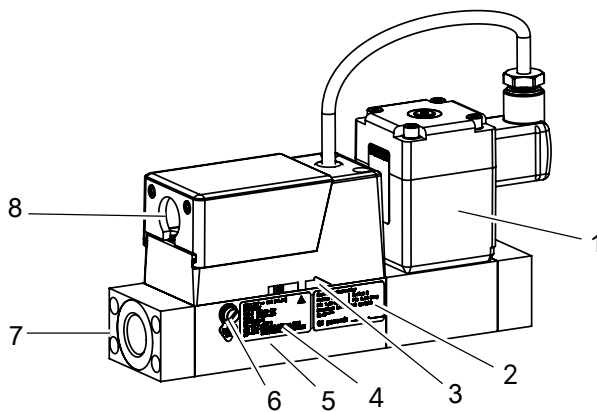

Fig. 4: Example of a variant MFC

1 Actuator	2 Calibration label
3 Flow direction marking	4 Type label
5 Base block	6 Functional earth connection
7 Medium connection	8 Electrical connection

## 3.2 Product identification

### 3.2.1 Type label

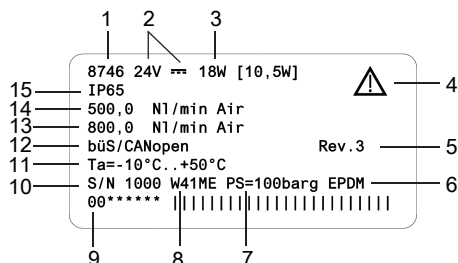

Fig. 5: Example of type label Type 8746

1 Type	2 Operating voltage
3 Power consumption	4 Note: Observe the operating instructions
5 Bürkert internal version	6 Sealing material
7 Burst pressure	8 Manufacture code
9 Article number	10 Serial number
11 Ambient temperature	12 Protocol
13 Nominal mass flow rate (Qnominal), unit and operating gas 2	14 Nominal mass flow rate (Qnominal), unit and operating gas 1
15 Degree of protection	

### 3.2.2 Calibration label

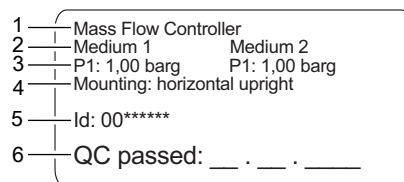

Fig. 6: Example of calibration label

1 Variant	2 Calibration medium
3 Calibration pressure	4 Installation position
5 Article number	6 Calibration date

### 3.2.3 Conformity marking

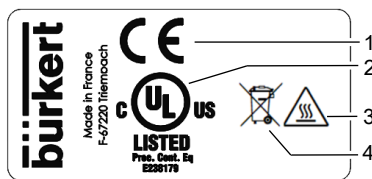

Fig. 7: Conformity label

1 CE marking	2 Certification marking for USA and/or Canada
3 Warning: hot surface	4 Indication for disposal

### 3.2.4 Symbols and markings on device



Earth terminal



Direct current

#### Industrial Ethernet variant

DC-B0-58-FF-FF- Example of marking of the MAC address  
FF

ETH1, ETH2 Ethernet connections

## 3.3 Display elements

### 3.3.1 Status indicator

The status indicator changes its colour based on the NAMUR recommendation NE 107. Refer to [NAMUR mode \[▶ 15\]](#).

The colour of the status indicator indicates:

- Whether device diagnostics are active or not. Diagnostics are active on the device and cannot be deactivated.
- If diagnostics are active, then the status indicator shows whether diagnostics events have been generated or not. If several diagnostics events have been generated, then the status indicator shows the diagnostics event with the highest priority.

If the status indicator flashes, then the device is selected in a man-machine interface such as the Bürkert Communicator software.

- ▶ To solve a problem indicated by the status indicator, refer to [Troubleshooting \[▶ 60\]](#)

### 3.3.2 NAMUR mode

The status indicator shows the status of the device and its peripherals, based on NAMUR recommendation 107 (NE 107).

If various alerts are present, the status indicator always shines in the colour of the highest prioritised alert (red = outage = highest priority).

Colour	Colour code	Status signal	Description
Red	5	Failure	Due to a malfunction in the device or its periphery, normal operation is not possible.
Orange	4	Check function	Work is being carried out on the device, which means that normal operation is temporarily not possible.
Yellow	3	Out of specification	The environmental or process conditions for the device are outside the specified range. Internal device diagnosis indicate problems in the device or process characteristics.
blue	2	Maintenance required	The device is in normal operation, although a function is briefly restricted. ▶ Service device
Green	1	Diagnosis active	Device is running faultlessly, diagnosis are active.
White	0	Diagnosis passive	Device is switched on, diagnosis are inactive.

Tab. 1: Status indicator according to NE 107

### 3.3.3 Network status indicator

#### Industrial Ethernet variant

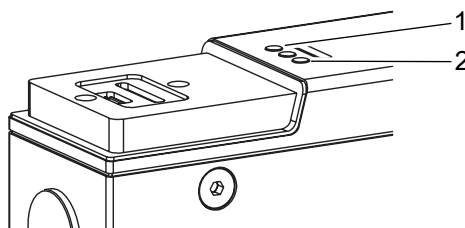

Fig. 8: Location and description of the LED's

1 Ethernet Port 1	2 Ethernet Port 2
-------------------	-------------------

### 3.3.4 Communication indicator

#### Industrial Ethernet variant | PROFIBUS variant

This LED shows the status of the communication between the device and the PLC (Programmable Logical Controller).

LED indicator	Description	Meaning
Green	RUN	Connection to the PLC is active.
Red	ERROR	Connection to the PLC is inactive.

Tab. 2: Description of the communication indicator

## 3.4 Functionality

### 3.4.1 Service-büs interface

#### Analogue variant | Industrial Ethernet variant | PROFIBUS variant

The Service-büs interface is used for short-term servicing of the device with the Bürkert Communicator.

The Bürkert Communicator runs under Windows. Refer to [Connect to the Bürkert Communicator \[▶ 45\]](#)

The USB-büs-Interface set, available as an accessory, is necessary. Refer to [Spare parts and accessories \[▶ 68\]](#)

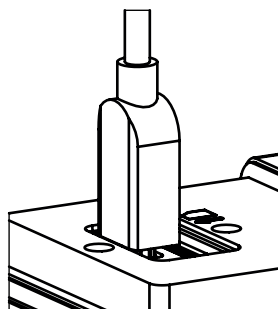

Fig. 9: būs stick, inserted in the related connector of the device

### 3.4.2 Control valve

#### MFC with proportional valve

The control valve is a direct-acting and normally-closed proportional valve.

The control valve provides the sealing function when the following conditions are met:

- The device is used within the specified pressure range.
- The device is equipped with a valve seat seal that is made of a soft material such as FKM, FFKM or EPDM.



If the valve seat seal is made of a hard material such as PCTFE, then the control valve may not be tight.

Valves with a seat size of 0.05 mm or 0.1 mm have a seat seal made of a hard material.

Unstable measured values may occur. Refer to [Unstable measured value \[▶ 64\]](#)

### 3.4.3 Memory card



If the memory card is defective or has been lost, contact the Bürkert sales office to purchase a new one.

The device can be delivered with a memory card that is inserted in the device. When the device is energised, there are two possibilities:

- If the inserted memory card contains device-specific data, the device automatically adopts this data. At the time of delivery, the memory card is preloaded with device-specific information. To view the stored data, refer to the file Device Description File.
- If the inserted memory card is empty, the device saves its own data onto the card. A new memory card is empty.

To download the file Device Description File:

- ▶ Access the page [Type 8746](#)
- ▶ Scroll down to **Downloads** > **Software**

The data stored on the memory card can be transferred to another device with the same article number. For example, data from a defective device can be transferred to a replacement device.

#### büS / CANopen variant

The büS/CANopen variant supports the config-client if no memory card is used.

- ▶ Activate this functionality in the Bürkert communicator under **General settings** > **Parameter** > **Act as a configuration client** > **Yes**.

For detailed information, refer to the "Software manual | Central configuration management".

- ▶ Access the page [Type 8746](#)
- ▶ Scroll down to **Downloads** > **User Manuals**

## 4 Technical data

### 4.1 Standards and directives

This product complies with the legal requirements applicable at the time of placing on the market and has been developed and tested in accordance with the relevant European directives/regulations and harmonized standards. The conformity is documented and, if necessary, supported by evidence. The EU Declaration of Conformity can be found behind the respective type on the home page [country.burkert.com](http://country.burkert.com)

### 4.2 Operating conditions

#### MFM

Ambient temperature	-10...+50 °C
Storage temperature	-10...+70 °C
Degree of protection (EN 60529 / IEC 60529)	IP65 <sup>1)</sup>
Medium temperature	<ul style="list-style-type: none"> <li>-10...+70 °C</li> <li>-10...+60 °C for oxygen</li> </ul>
Medium	Refer to the type label Clean and dry. Quality classes according to DIN ISO 8573-1.
Operating pressure	max. 25 bar (g)
Relative air humidity	< 95 %, non-condensing

#### MFC with proportional valve

Ambient temperature	-10...+50 °C
Storage temperature	-10...+70 °C
Degree of protection (EN 60529 / IEC 60529)	IP65 <sup>1)</sup>
Medium temperature	<ul style="list-style-type: none"> <li>-10...+70 °C</li> <li>-10...+60 °C for oxygen</li> </ul>
Medium	Refer to the type label Clean and dry. Quality classes according to DIN ISO 8573-1.
Operating pressure	Max. 25 bar (g) (depending on the nominal diameter of the valve)
Relative air humidity	< 95 %, non-condensing

<sup>1)</sup> When cables or plugs and sockets are connected correctly, verified by Bürkert, not evaluated by UL.

## MFC with motor valve

Ambient temperature	-10...+50 °C
Storage temperature	-10...+70 °C
Degree of protection (EN 60529 / IEC 60529)	IP65 <sup>1)</sup>
Medium temperature	<ul style="list-style-type: none"> <li>• -10...+70 °C</li> <li>• -10...+60 °C for oxygen</li> </ul>
Medium	Refer to the type label Clean and dry. Quality classes according to DIN ISO 8573-1.
Operating pressure	Max. 22 bar (g) (depending on the nominal diameter of the valve)
Relative air humidity	< 95 %, non-condensing

## 4.3 Medium data

### MFM

Calibration medium	Operating fluid or air
Mass flow rate range (reference to N <sub>2</sub> (I <sub>N</sub> /min))	20...2500 I <sub>N</sub> /min <sup>2)</sup>
Turndown ratio	1:50 <sup>3)</sup>
Repeatability	±0.1% of the full scale
Measurement accuracy, after 15 minute warm-up time	±1.5% <sup>4)</sup> of the measured value ±0.3% <sup>4)</sup> of the full scale
Response time (t <sub>95%</sub> )	< 500 ms

2) Exact range depends on the product base-block size and on the gas used. Refer to the datasheet related to the product type.

3) Larger measuring range available on request.

4) If the operation medium deviates from the calibration medium, the actual measurement accuracy might vary from the value specified in the data sheet. If the medium is natural gas, the measurement accuracy depends on the composition of the natural gas, which can vary depending on the origin and season.

### MFC with proportional valve

Calibration medium	Operating fluid or air
Mass flow rate range (reference to N <sub>2</sub> (I <sub>N</sub> /min))	20...1500 I <sub>N</sub> /min <sup>2</sup>
Turndown ratio	1:50 <sup>3</sup>
Repeatability	±0.1% of the full scale
Measurement accuracy, after 15 minute warm-up time	±1.5% <sup>4</sup> of the measured value ±0.3% <sup>4</sup> of the full scale
Settling time (t <sub>95%</sub> )	< 500 ms

### MFC with motor valve

Calibration medium	Operating fluid or air
Mass flow rate range (reference to N <sub>2</sub> (I <sub>N</sub> /min))	20...2500 I <sub>N</sub> /min <sup>2</sup>
Turndown ratio	1:50 <sup>3</sup>
Repeatability	±0.1% of the full scale
Measurement accuracy, after 15 minute warm-up time	±2% <sup>4</sup> of the measured value ±0.5% <sup>4</sup> of the full scale
Settling time (t <sub>95%</sub> )	< 5 s

### Quality of the medium

#### NOTICE!

The medium must obey the quality criteria to obey the following requirements:

- ▶ the necessary measurement accuracy of the device
- ▶ to meet the safety requirements
- ▶ to meet the closed-loop control accuracy of an MFC

✓ For further information on the quality criteria, refer to ISO 8573-1.

Criteria	Quality class	Value
Maximum particle size	2	1 µm
Maximum particle density	2	1 mg/m <sup>3</sup>
Maximum dew point under pressure	4	3 °C
Maximum oil concentration	1	0.01 mg/m <sup>3</sup>

Tab. 3: Quality criteria of the medium, ISO 8573-1, Compressed Air - Part 1: Contaminants and purity classes

### 4.3.1 Pressure loss

#### MFM

A mass flow meter has a pressure loss that depends on the following parameters:

- the flow rate value
  - the size of the device connections
  - the type of the device connections
  - the size of the device base-block
  - the type of operating medium
- Determine the pressure-loss value depending on whether the medium is air or a gas other than air.

#### 4.3.1.1 Medium is air or nitrogen

If the medium is air or nitrogen, read the pressure-loss value directly from the diagram in following figures.

The diagram shows an example of the pressure loss characteristics when air flows through. To determine the pressure loss of other gases, the corresponding air equivalent must first be calculated and the base block used for the other gas taken into account.

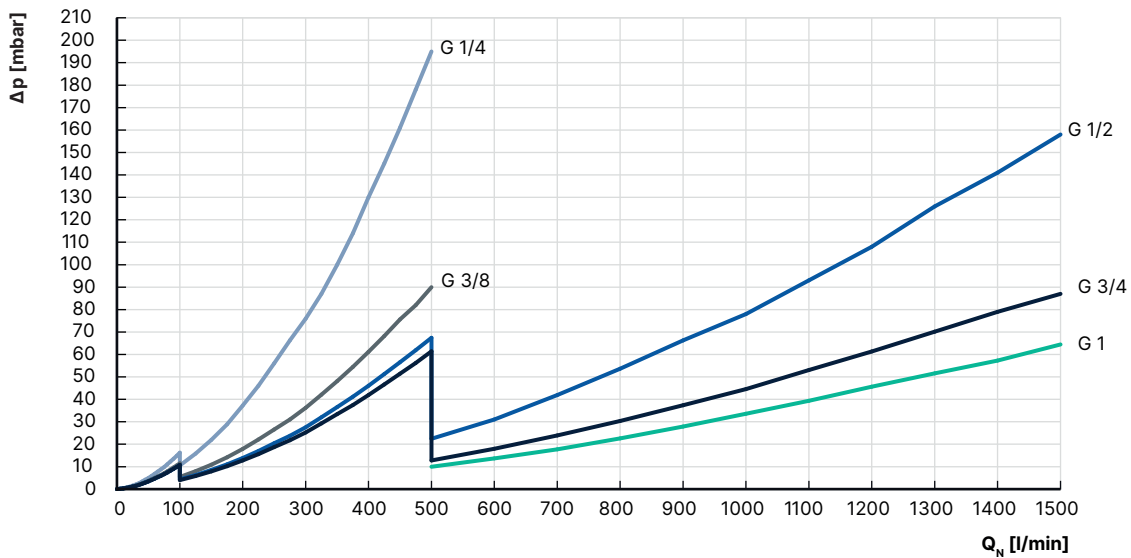

Fig. 10: Pressure loss diagram MFM

#### 4.3.1.2 Medium is not air or nitrogen

If the medium is not air or nitrogen, determine the pressure loss as follows:

- Read the air pressure-loss  $\Delta P_{Air}$  from the diagram (approach  $Q_{Gas} = Q_{Air}$ ).
- Calculate the pressure loss  $\Delta P_{Gas}$  with the following formula.

$$\Delta P_{Gas} = \Delta P_{Air} \cdot \sqrt{\frac{\rho_{N, Gas}}{\rho_{N, Air}}}$$

Fig. 11: Formula to calculate the pressure loss in an MFM

$\Delta P_{Gas}$	Pressure loss of the medium
$\Delta P_{Air}$	Pressure loss of air
$\rho_{N, Gas}$	Density of the medium at the standard conditions according to DIN 1343 $P_N = 1013.25 \text{ mbar}, T_N = 273.15 \text{ K}$
$\rho_{N, Air}$	Density of air at the standard conditions according to DIN 1343 $P_N = 1013.25 \text{ mbar}, T_N = 273.15 \text{ K}$

Example for argon gas that flows through an MFM with 1/4" threaded connections:

- ▶ If the flow rate is 140 l<sub>N</sub>/min then the air pressure-loss P<sub>air</sub> as given in previous figure is 140 mbar.
- ▶ The pressure loss for argon gas at a flow rate of 1400 l<sub>N</sub>/min is 164,4 mbar as given by the following formula.

$$\Delta P_{Argon} = 140 \text{ mbar} \cdot \sqrt{\frac{1,784}{1,294}} = 164,4 \text{ mbar}$$

Fig. 12: Calculation of the pressure loss for argon gas

## 4.4 Electrical data

### MFM Analogue

Operating voltage	24 V $\overline{=}$ $\pm 10\%$
Power consumption	< 2 W
Analogue input for the measured value 0/4...20 mA	Maximum input impedance: 200 $\Omega$ Resolution: 5 $\mu$ A
Analogue input for the measured value 0...5/10 V	Minimum input impedance: 20 k $\Omega$ Resolution: 2,5 mV
Analogue output for the measured value 0/4...20 mA	Maximum loop impedance: 400 $\Omega$ at an operating voltage of 24 V $\overline{=}$ Resolution: 20 $\mu$ A
Analogue output for the measured value 0...5/10 V	Maximum current: 20 mA Resolution: 10 mV
Digital input	<ul style="list-style-type: none"> <li>• 0...0.2 V to activate level 1</li> <li>• 1...4 V or open to activate level 2</li> <li>• 5...28 V to activate level 3</li> </ul>
Relay output type	Normally closed contact (break contact), free of potential
Maximum ratings	1 A, 30 V, 30 VA
Electrical connections	<ul style="list-style-type: none"> <li>• M12 plug 5-pin A-coding</li> <li>• M12 socket 5-pin A-coding</li> <li>• service bÜS interface</li> </ul>
Minimum temperature rating of the cable to be connected to the field wiring terminals:	90 °C

### MFM Industrial Ethernet

Operating voltage	24 V $\overline{=}$ $\pm 10\%$
Power consumption	< 2 W
Communication interface	Industrial Ethernet: PROFINET, EtherNet/IP, EtherCAT, Modbus TCP
Electrical connections	<ul style="list-style-type: none"> <li>• M12 plug 5-pin A-coding</li> <li>• 2 M8 socket 4-pin D-coding</li> <li>• service bÜS interface</li> </ul>
Minimum temperature rating of the cable to be connected to the field wiring terminals:	90 °C

### MFM büS/CANopen

Operating voltage	24 V $\pm$ 10 %
Power consumption	< 2 W
Communication interface	büS and CANopen. The communication type can be selected with the Bürkert Communicator software.
Electrical connections	M12 plug 5-pin A-coding
Minimum temperature rating of the cable to be connected to the field wiring terminals:	90 °C

### MFM PROFIBUS

Operating voltage	24 V $\pm$ 10 %
Power consumption	< 3 W
Communication interface	PROFIBUS-DP-V1
Electrical connections	<ul style="list-style-type: none"><li>• M12 plug 5-pin A-coding</li><li>• M12 socket 5-pin B-coding</li><li>• service büS interface</li></ul>
Minimum temperature rating of the cable to be connected to the field wiring terminals:	90 °C

## MFC Analogue

Operating voltage	24 V $\overline{=}$ $\pm 10\%$ residual ripple < 2 %
Power consumption	Refer to type label
Analogue input for the measured value 0/4...20 mA	Maximum input impedance: 200 $\Omega$ Resolution: 5 $\mu$ A
Analogue input for the measured value 0...5/10 V	Minimum input impedance: 20 k $\Omega$ Resolution: 2,5 mV
Analogue output for the measured value 0/4...20 mA	Maximum loop impedance: 400 $\Omega$ at an operating voltage of 24 V $\overline{=}$ Resolution: 20 $\mu$ A
Analogue output for the measured value 0...5/10 V	Maximum current: 20 mA Resolution: 10 mV
Digital input	<ul style="list-style-type: none"> <li>• 0...0.2 V to activate level 1</li> <li>• 1...4 V or open to activate level 2</li> <li>• 5...28 V to activate level 3</li> </ul>
Relay output type	Normally closed contact (break contact), free of potential
Maximum ratings	1 A, 30 V, 30 VA
Electrical connections	<ul style="list-style-type: none"> <li>• M12 plug 5-pin A-coding</li> <li>• M12 socket 5-pin A-coding</li> <li>• service b<math>\ddot{u}</math>S interface</li> </ul>
Minimum temperature rating of the cable to be connected to the field wiring terminals:	90 $^{\circ}$ C

## MFC Industrial Ethernet

Operating voltage	24 V $\overline{=}$ $\pm 10\%$ residual ripple < 2 %
Power consumption	Refer to type label
Communication interface	Industrial Ethernet: PROFINET, EtherNet/IP, EtherCAT, Modbus TCP
Electrical connections	<ul style="list-style-type: none"> <li>• M12 plug 5-pin A-coding</li> <li>• 2 M8 socket 4-pin D-coding</li> <li>• service b<math>\ddot{u}</math>S interface</li> </ul>
Minimum temperature rating of the cable to be connected to the field wiring terminals:	90 $^{\circ}$ C

## MFC büS/CANopen

Operating voltage	24 V $\pm 10\%$ residual ripple < 2 %
Power consumption	Refer to type label
Communication interface	büS and CANopen. The communication type can be selected with the Bürkert Communicator software.
Electrical connections	M12 plug 5-pin A-coding
Minimum temperature rating of the cable to be connected to the field wiring terminals:	90 °C

## MFC PROFIBUS

Operating voltage	24 V $\pm 10\%$ residual ripple < 2 %
Power consumption	Refer to type label
Communication interface	PROFIBUS-DP-V1
Electrical connections	<ul style="list-style-type: none"> <li>• M12 plug 5-pin A-coding</li> <li>• M12 socket 5-pin B-coding</li> <li>• service büS interface</li> </ul>
Minimum temperature rating of the cable to be connected to the field wiring terminals:	90 °C

## 4.5 Communication

### 4.5.1 Industrial Ethernet: EtherCAT



Ethernet interface X1, X2	X1: EtherCAT IN X2: EtherCAT OUT
Acyclic communication (CoE)	SDO
Type	Complex Slave
FMMUs	8
Sync managers	4
Transmission speed	100 Mbit/s
Data transport layer	Ethernet II, IEEE 802.3

EtherCAT® is a registered trademark and patented technology, licensed by Beckhoff Automation GmbH, Germany.

## 4.5.2 Industrial Ethernet: EtherNet/IP

Pre-defined standard objects	Identity Object (0x01) Message Router Object (0x02) Assembly Object (0x04) Connection Manager (0x06) DLR Object (0x47) QoS Object (0x48) TCP/IP Interface Object (0xF5) Ethernet Link Object (0xF6)
DHCP	supported
BOOTP	supported
Transmission speed	10 and 100 Mbit/s
Duplex modes	Half duplex, full duplex, auto-negotiation
MDI modes	MDI, MDI-X, Auto-MDI-X
Data transport layer	Ethernet II, IEEE 802.3
Address Conflict Detection (ACD)	supported
DLR (ring topology)	supported
CIP reset service	Identity Object Reset Service Type 0 and Type 1

## 4.5.3 Industrial Ethernet: Modbus TCP

Modbus function codes	1, 2, 3, 4, 16
Transmission speed	10 and 100 Mbit/s
Data transport layer	Ethernet II, IEEE 802.3

## 4.5.4 Industrial Ethernet: PROFINET IO

Topology recognition	LLDP, SNMP V1, MIB2, Physical Device
Minimum cycle time	2 ms
IRT	not supported
MRP media redundancy	MRP client is supported
Other supported functions	DCP, VLAN Priority Tagging, Shared Device
Transmission speed	100 Mbit/s
Data transport layer	Ethernet II, IEEE 802.3
PROFINET IO specification	V2.42
Application Relations (AR)	The device can simultaneously process up to 2 IO ARs, 1 Supervisor AR, and 1 Supervisor DA AR.

## 4.6 Mechanical data

Dimensions	Refer to data sheet <a href="#">Type 8746</a>
Base block	Aluminium or stainless steel 1.4305
Housing	Painted die-cast aluminium
Seal	Refer to the type label
Status indicator	PMMA
Parts in contact with the medium (sensor)	1.4404, Al <sub>2</sub> O <sub>3</sub> , PPS GF40, epoxy resin, silicon, silicon nitride

## 5 Medium connection



Risk of injury or material damage when working on the device or system.

- ▶ Read and observe the chapter **Safety** [▶ 8] before working on the device or system.

### 5.1 Possible medium connections

- G-internal-threaded connections according to DIN ISO228/1
- NPT-internal-threaded connections according to ASME/ ANSI B 1.20.1
- Flange connection
- Connections with external-threaded vacuum fittings
- Connections with external-threaded compression fittings
- Tri-Clamp

### 5.2 Installation procedure



#### **WARNING!**

Risk of injury that is due to leakage.

At a low mass flow rate and a high pressure, make sure that the installation is tight. The tightness prevents incorrect measurements or leakage of the medium.

To make sure that the installation is tight, observe the following instructions:

- ▶ Use compression fittings. Mount the compression fittings in a way that they are not subject to any stresses.
- ▶ Use pipes with diameter that is adapted to the medium connection of the device, and a smooth surface.

#### **NOTICE!**

Malfunction that is due to contamination.

If a contaminated medium is used, then install a filter upstream of the device. The filter mesh-size must be smaller than 25 µm. The filter ensures problem-free functioning of the device.

#### 5.2.1 G1/8"-internal-threaded connections

- ▶ Remove the protective cap that closes the threaded connection.
- ▶ Do the medium connection on one side of the device.
- ▶ Obey the instructions that are given by the manufacturer of the fitting used.
- ▶ Obey the torques that are given by the manufacturer of the fitting used.
- ▶ Do the medium connection on the other side of the device in the same way.

#### 5.2.2 NPT1/8"-internal-threaded connections

- ▶ Do the medium connection on one side of the device.

- ▶ Obey the instructions that are given by the manufacturer of the fitting used.
- ▶ Obey the torques that are given by the manufacturer of the fitting used.
- ▶ Do the medium connection on the other side of the device in the same way.

### 5.2.3 Flange connections

A variant with flange connections is mounted on a process connection plate by the manufacturer.

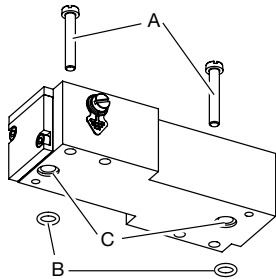

- ▶ Use the M4 screws [A] and O-ring sealings [B] delivered with the device.
- ▶ Place the O-ring sealings in the cavity [C] of the base block.
- ▶ Tighten the screws to a torque of 2,7...2,9 N·m (1,99...2,14 lbf·ft).

Fig. 13: Flange connection with screws and O-ring sealings

### 5.2.4 Connections with external-threaded vacuum fittings

- ▶ Remove the protective cap that closes the connection.
- ▶ Do the medium connection on one side of the device.
- ▶ Obey the instructions that are given by the manufacturer of the fitting used.
- ▶ **CAUTION! To avoid damage on the sealing of the medium connection, please make sure to lock the hexagonal part in place with a second wrench.**  
Obey the torques that are given by the manufacturer of the fitting used.
- ▶ Do the medium connection on the other side of the device in the same way.

### 5.2.5 Connections with external-threaded compression fittings

- ▶ Do the medium connection on one side of the device.
- ▶ Obey the instructions that are given by the manufacturer of the fitting used.
- ▶ **CAUTION! To avoid damage on the sealing of the medium connection, please make sure to lock the hexagonal part in place with a second wrench.**  
Obey the torques that are given by the manufacturer of the fitting used.
- ▶ Do the medium connection on the other side of the device in the same way.

### 5.2.6 Tri-clamp connections

- ▶ Remove the protective cap that closes the threaded connection.
- ▶ Do the medium connection on one side of the device.
- ▶ Obey the instructions that are given by the manufacturer of the fitting used.
- ▶ Do the medium connection on the other side of the device in the same way.

## 6 Electrical connection



Risk of injury or material damage when working on the device or system.

- ▶ Read and observe the chapter [Safety \[▶ 8\]](#) before working on the device or system.

### 6.1 Additional documentation

Further documentation concerning the product:

- ▶ Access the page [Type 8746](#)
- ▶ Scroll down to **Downloads**
- ▶ Or enter the article number from the type label in the search bar.

### 6.2 Wire the variant büS /CANopen

#### NOTICE!

UL approved versions must be supplied in one of the following ways:

- ▶ "Limited Energy Circuit" (LEC), according to UL / IEC61010-1
- ▶ "Limited Power Source" (LPS), according to UL / IEC60950
- ▶ SELV / PELV with UL-approved overcurrent protection, designed according to UL / IEC61010-1, Table 18 (e.g. Block PM-0124-020-0)
- ▶ NEC Class 2 power supply unit

#### 6.2.1 With büS extension cables from Bürkert



Requirements for the correct operation of the device: refer to the Cabling Guide | büS/EDIP.

- ▶ Access the page [Type 8746](#)
- ▶ Scroll down to **Downloads** > **User Manuals**

To wire the device, use büS extension cables from Bürkert.

- ▶ Screw the mating female connector onto the 5-pin male connector. Apply the tightening torque specified by the manufacturer of the mating female connector.
- ▶ Do the functional earthing of the device. Refer to [Connect the functional earth \[▶ 43\]](#).

#### 6.2.2 With büS cables from Bürkert



Requirements for the correct operation of the device: refer to the Cabling Guide | büS/EDIP.

- ▶ Access the page [Type 8746](#)
- ▶ Scroll down to **Downloads** > **User Manuals**

To wire the device, büS cables and mating female connectors are available from Bürkert.

If a bus cable from Bürkert is used, then observe the signals of the conductors.

Colour of the bus cable conductor	Signal
red	24 V $\equiv$
black	GND
white	CAN_H
blue	CAN_L

Tab. 4: Signals of the bus cable conductors

### NOTICE!

If an own mating female connector is used, then observe the following requirements for the correct operation of the device.

- ▶ Use a mating female connector with shield connection.
- ▶ Make sure that the bus cable passes through the mating female connector. The bus cable that is available from Bürkert has an external diameter of 8.2 mm.

5-pin M12 male connector (A coding)	Pin	Assignment
	1	Shield
	2	24 V $\equiv$
	3	GND
	4	CAN_H
	5	CAN_L
	6	Coding lug

M12 thread is internally connected to FE

Tab. 5: Pin assignment, 5-pin M12 male connector (A coding) of the device

- ▶ Wire the mating female connector. Observe the instructions that are given by the manufacturer of the mating female connector.
- ▶ Insert each conductor into the appropriate pin.
- ▶ Take a strand of the cable shielding and insert the strand into pin 1.
- ▶ Screw the mating female connector to the 5-pin male connector, to the torque given by the manufacturer of the mating female connector.
- ▶ Do the functional earthing of the device. Refer to [Connect the functional earth \[▶ 43\]](#)

### 6.2.3 With CANopen cables



Requirements for the correct operation of the device.

- ▶ Use shielded CANopen cables. The cable shielding can be either a braid shielding or a foil shielding.

To wire the device, mating female connectors are available from Bürkert.

## NOTICE!

Requirements for the correct operation of the device.

- ▶ Use a mating female connector with shield connection.
- ▶ Observe the specifications for the cable and conductors, that are given by the manufacturer of the mating female connector.

5-pin M12 male connector (A coding)	Pin	Assignment
	1	Shield
	2	24 V $\equiv$
	3	GND
	4	CAN_H
	5	CAN_L
	6	Coding lug

M12 thread is internally connected to FE

Tab. 6: Pin assignment, 5-pin M12 male connector (A coding) of the device

- ▶ Wire the mating female connector. Observe the instructions that are given by the manufacturer of the mating female connector.
- ▶ Insert each conductor into the appropriate pin.
- ▶ Take a strand of the cable shielding and insert the strand into pin 1.
- ▶ Screw the mating female connector to the 5-pin male connector, to the torque given by the manufacturer of the mating female connector.
- ▶ Do the functional earthing of the device. Refer to [Connect the functional earth \[▶ 43\]](#)

## 6.3 Wire the variant Analogue



Requirements for the correct operation of the device.

- ▶ Use shielded cables. The cable shielding can be either a braid shielding or a foil shielding.

## NOTICE!

Requirements for the correct operation of the device.

- ▶ Use a mating female connector with shield-connection transfer at the union nut.
- ▶ Use a mating male connector with shield-connection transfer at the union nut.
- ▶ Use a mating male connector and a mating female connector that are in metal.
- ▶ Observe the specifications for the cable and conductors, that are given by the manufacturer of the mating female or male connector.

## NOTICE!

UL approved versions must be supplied in one of the following ways:

- ▶ "Limited Energy Circuit" (LEC), according to UL / IEC61010-1
- ▶ "Limited Power Source" (LPS), according to UL / IEC60950
- ▶ SELV / PELV with UL-approved overcurrent protection, designed according to UL / IEC61010-1, Table 18 (e.g. Block PM-0124-020-0)
- ▶ NEC Class 2 power supply unit

## MFM

5-pin M12 male connector	Pin	Assignment
	1	GND for the analogue output
	2	24 V $\equiv$
	3	GND
	4	Not connected
	5	Analogue output for the measured value
	6	Coding lug

M12 thread is internally connected to FE

Tab. 7: Pin assignment, 5-pin M12 male connector (A coding) of the device

## MFC

5-pin M12 male connector	Pin	Assignment
	1	GND for the analogue output and the set-point input
	2	24 V $\equiv$
	3	GND
	4	Set-point input
	5	Analogue output for the measured value
	6	Coding lug

M12 thread is internally connected to FE

Tab. 8: Pin assignment, 5-pin M12 male connector (A coding) of the device

- ▶ Wire the mating female connector according to the pin assignment of the M12 male connector. Observe the instructions that are given by the manufacturer of the mating female connector.
- ▶ Connect the cable shielding to the mating female connector.
- ▶ Screw the mating female connector to the 5-pin male connector, to the torque that is given by the manufacturer of the mating female connector.

5-pin M12 female connector	Pin	Assignment
<p>M12 thread is internally connected to FE</p>	1	GND for the digital input
	2	Digital input +
	3	Relay - Reference contact
	4	Relay - Normally closed contact (Break contact)
	5	Relay - Normally open contact (Make contact)
	6	Coding lug

Tab. 9: Pin assignment, 5-pin M12 female connector of the device

- ▶ Wire the mating male connector according to the pin assignment of the M12 female connector. Observe the instructions that are given by the manufacturer of the mating male connector.
- ▶ Connect the cable shielding to the mating male connector.
- ▶ Screw the mating male connector to the 5-pin female connector, to the torque given by the manufacturer of the mating male connector.
- ▶ Do the functional earthing of the device. Refer to [Connect the functional earth \[▶ 43\]](#)

### 6.3.1 Digital input

The D-sub DE-9 male connector has a digital input. A digital input is used to remotely trigger a function.

#### Available functions on MFM

- Reset the totalizer for the active gas.
- Select which gas is active among 3 gases.

Default assignment
No assignment

#### Available functions on MFC

- Start the function autotune.
- Trigger the remote control of the actuator or trigger the control of the actuator by the device.
- Reset the totalizer for the active gas.
- Select which gas is active among 3 gases.
- Select the set-point value.

Default assignment
Start autotune

- ▶ To select the function to be remotely triggered over the digital input, use the Bürkert Communicator. Only one of the available functions can be associated to the digital input.

A function has up to 3 possible switching levels which may trigger different actions. The following table gives the actions that are associated to the switching levels, and how each level is activated.

### MFM | Digital input 1 inverted

Function	Level 1 "low" <sup>5)</sup>	Level 2 "open" <sup>6)</sup>	Level 3 "high" <sup>7)</sup>
Reset totalizer	Resets the Totalizer	-	-
Gas selection for 2 gases	Switches to gas 2	Switches to gas 1	Switches to gas 1
Gas selection for 3 gases <sup>8)</sup>	Switches to gas 2	Switches to gas 1	Switches to gas 3

Tab. 10: Actions triggered by the switching levels

### MFM | Digital input 1 not inverted

Function	Level 1 "low" <sup>5)</sup>	Level 2 "open" <sup>6)</sup>	Level 3 "high" <sup>7)</sup>
Reset totalizer	-	-	Resets the Totalizer
Gas selection for 2 gases	Switches to gas 1	Switches to gas 1	Switches to gas 2
Gas selection for 3 gases <sup>8)</sup>	Switches to gas 3	Switches to gas 1	Switches to gas 2

Tab. 11: Actions triggered by the switching levels

MAN 1000242105 EN Version: K Status: RL (released | freigegeben) printed: 23.03.2026

5) Digital input is connected to GND  
 6) Digital input is not connected (alternatively: 1..4 V  $\overline{\text{---}}$ )  
 7) Digital input is connected to +24 V  $\overline{\text{---}}$  (alternatively: 5...28 V  $\overline{\text{---}}$ )  
 8) Not possible to select the 4<sup>th</sup> gas curve

## MFC | Digital input 1 inverted

Function	Level 1 "low" <sup>9)</sup>	Level 2 "open" <sup>10)</sup>	Level 3 "high" <sup>11)</sup>
Start autotune	Starts <b>Autotune</b>	-	-
Set-point value source	Triggers <b>Stored set-point active</b>	-	Triggers <b>Open-loop control mode</b>
Reset totalizer	Resets the <b>Totalizer</b>	-	-
Gas selection for 2 gases	Switches to gas 2	Switches to gas 1	Switches to gas 1
Gas selection for 3 gases <sup>12)</sup>	Switches to gas 2	Switches to gas 1	Switches to gas 3
Actuator control	Opens the actuator completely	-	Closes the actuator
Close actuator	Closes the actuator	-	-

Tab. 12: Actions triggered by the switching levels

## MFC | Digital input 1 not inverted

Function	Level 1 "low" <sup>9)</sup>	Level 2 "open" <sup>10)</sup>	Level 3 "high" <sup>11)</sup>
Start autotune	-	-	Starts <b>Autotune</b>
Set-point value source	Triggers <b>Open-loop control mode</b>	-	Triggers <b>Stored set-point active</b>
Reset totalizer	-	-	Resets the <b>Totalizer</b>
Gas selection for 2 gases	Switches to gas 1	Switches to gas 1	Switches to gas 2
Gas selection for 3 gases <sup>12)</sup>	Switches to gas 3	Switches to gas 1	Switches to gas 2
Actuator control	Closes the actuator	-	Opens the actuator completely
Close actuator	-	Closes the actuator	Closes the actuator

Tab. 13: Actions triggered by the switching levels

### 6.3.2 Relay output

The 5-pin M12 female connector has a relay output.

<sup>9)</sup> Digital input is connected to GND

<sup>10)</sup> Digital input is not connected (alternatively: 1..4 V  $\overline{\text{---}}$ )

<sup>11)</sup> Digital input is connected to +24 V  $\overline{\text{---}}$  (alternatively: 5...28 V  $\overline{\text{---}}$ )

<sup>12)</sup> Not possible to select the 4<sup>th</sup> gas curve

## MFM

The relay switching can show the following events:

- A warning message has been generated. For example if the supply voltage is too high, then a warning message is generated.
- A failure message has been generated. For example if a sensor failure is detected, then a failure message is generated.

### Default assignment

Empty pipe detected

Gas bubbles in the system

## MFC

The relay switching can show the following events:

- A warning message has been generated. For example if the supply voltage is too high, then a warning message is generated.
- A failure message has been generated. For example if a sensor failure is detected, then a failure message is generated.
- The set-point value cannot be reached.
- The device is doing an Autotune.
- The **Set-point value source** has changed.

### Default assignment

The set-point value cannot be reached

- ▶ To select the events that are assigned to the relay output, use the Bürkert Communicator software. Several events can be associated to the relay output.

## 6.4 Wire the variant Industrial Ethernet

### NOTICE!

Requirements for the correct operation of the device.

- ▶ Use a power supply unit with sufficient power.
- ▶ Use only Industrial Ethernet shielded cables with a category CAT-5e or higher.
- ▶ Connect each cable end to the functional earth.
- ▶ For an MFC pay attention to the maximum permissible residual ripple on the operating voltage (residual ripple < 2 %).

### NOTICE!

UL approved versions must be supplied in one of the following ways:

- ▶ "Limited Energy Circuit" (LEC), according to UL / IEC61010-1
- ▶ "Limited Power Source" (LPS), according to UL / IEC60950
- ▶ SELV / PELV with UL-approved overcurrent protection, designed according to UL / IEC61010-1, Table 18 (e.g. Block PM-0124-020-0)
- ▶ NEC Class 2 power supply unit

5-pin M12 male connector (A coding)	Pin	Assignment
	1	Shielding
	2	24 V $\equiv$
	3	GND
	4	Not connected
	5	Not connected
	6	Coding lug

M12 thread is internally connected to FE

Tab. 14: Pin assignment, 5-pin M12 male connector (A coding) of the device

4-pin M8 female connector (D coding)	Pin	Assignment
	1	Tx +
	2	Rx +
	3	Tx -
	4	Rx -
	5	Coding lug

M8 thread is internally connected to FE

Tab. 15: Pin assignment, 4-pin M8 (D coding) of the device

- ▶ If a protocol other than EtherCAT is used, plug an Ethernet cable in one or both sockets.
- ▶ If the EtherCAT protocol is used, plug the incoming Ethernet cable (coming from the PLC) into the socket marked ETH1 and plug the outgoing Ethernet cable into the socket marked ETH2.

## 6.5 Change the network parameters

### Industrial Ethernet variant



The Industrial Ethernet variants Ethernet/IP and ModbusTCP have the same default IP address 192.168.1.100, Profinet devices have 0.0.0.0 by default.

- ▶ Before commissioning the device, change its network parameters.
- ▶ If several devices must be connected to the same Industrial Ethernet network, then connect one device at a time and change its network parameters.

## 6.5.1 Over the product web server

### NOTICE!

Security risk due to default passwords.

Unauthorised persons can log in to the web server and change the parameters.

- ▶ Change the default passwords.
- ▶ If the web server is not required, disable access using Bürkert Communicator. Refer to [Configuration with Bürkert Communicator \[▶ 45\]](#).

Prerequisites:

- The industrial Ethernet variant is not EtherCAT
- Digital device (PC, tablet,...) with a web browser.
- Possibly, a USB-Ethernet adapter.
- ▶ Connect the device to the digital device with an Ethernet cable. Alternatively, connect the device to the PC with a USB-Ethernet adapter.
- ▶ Energise the digital device and the device.
- ▶ If the device is connected to the digital device over a USB-Ethernet adapter, then configure the IP address of the USB-Ethernet adapter. Else, configure the IP address of the network card of the digital device.
- ▶ Change the IP address to 192.168.1.xxx, where xxx is different from 100.
- ▶ Open the web browser. In the address bar of the web browser, enter 192.168.1.100.
  - ✓ The home page of the web server opens. Some device data are shown.
- ▶ Open a web server session, to configure the network parameters of the device.
- ▶ If you are not automatically invited to log in, select **Login**.
- ▶ **User name**: enter admin
- ▶ **User password**: enter admin
- ▶ Click **Login**.
- ▶ Change the default passwords with customised passwords.
- ▶ Change the network parameters of the device.
- ▶ Select **Industrial communication** > **Configuration**.
- ▶ Change the parameters.
- ▶ To save the changes, select **Apply**.
- ▶ To update the parameters, select **Restart**.
- ✓ The device restarts.
- ✓ The network parameters of the device are changed.

## 6.5.2 Over the Bürkert Communicator software

- ▶ Connect the device to the Bürkert Communicator software. Refer to [Configuration with Bürkert Communicator \[▶ 45\]](#).
- ▶ Change the network parameters of the device.
- ▶ Select **Industrial communication** > **Parameter**.

- ▶ Change the parameters.
- ▶ To update the parameters, restart the device.
- ✓ The device restarts.
- ✓ The network parameters of the device are changed.

## 6.6 Wire the variant Profibus



Requirements for the correct operation of the device.

- ▶ Use shielded cables. The cable shielding can be either a braid shielding or a foil shielding.

### NOTICE!

Requirements for the correct operation of the device.

- ▶ Use a mating female connector with shield-connection transfer at the union nut.
- ▶ Use a mating male connector with shield-connection transfer at the union nut.
- ▶ Use a mating male connector and a mating female connector that are in metal.
- ▶ Observe the specifications for the cable and conductors, that are given by the manufacturer of the mating female or male connector.

### NOTICE!

UL approved versions must be supplied in one of the following ways:

- ▶ "Limited Energy Circuit" (LEC), according to UL / IEC61010-1
- ▶ "Limited Power Source" (LPS), according to UL / IEC60950
- ▶ SELV / PELV with UL-approved overcurrent protection, designed according to UL / IEC61010-1, Table 18 (e.g. Block PM-0124-020-0)
- ▶ NEC Class 2 power supply unit

5-pin M12 male connector	Pin	Assignment
	1	Shielding
	2	24 V $\overline{---}$
	3	GND
	4	Not connected
	5	Not connected
	6	Coding lug

M12 thread is internally connected to FE

Tab. 16: Pin assignment, 5-pin M12 male connector (A coding) of the device

- ▶ Wire the mating female connector according to the pin assignment of the M12 male connector. Observe the instructions that are given by the manufacturer of the mating female connector.
- ▶ Connect the cable shielding to the mating female connector.

5-pin M12 female connector	Pin	Assignment
<p>M12 thread is internally connected to FE</p>	1	5 V
	2	RxD / TxD (line A)
	3	DGND
	4	RxD / TxD (line B)
	5	Not connected
	6	Coding lug

Tab. 17: Pin assignment, 5-pin M12 female connector (B coding) of the device

- ▶ Wire the mating male connector according to the pin assignment of the M12 female connector. Observe the instructions that are given by the manufacturer of the mating male connector.
- ▶ Connect the cable shielding to the mating male connector.
- ▶ Screw the mating male connector to the 5-pin female connector, to the torque given by the manufacturer of the mating male connector.
- ▶ Do the functional earthing of the device. Refer to chapter: [Connect the functional earth \[▶ 43\]](#)

## 6.7 Change the Profibus network parameters

### PROFIBUS variant



All the variants Profibus have the same default Profibus adress 126.

- ▶ Before commissioning the device, change its network parameters.
- ▶ If several devices must be connected to the same Profibus network, then connect one device at a time and change its network parameters.

#### 6.7.1 Over the Bürkert Communicator software

- ▶ Connect the device to the Bürkert Communicator software. Refer to [Configuration with Bürkert Communicator \[▶ 45\]](#).
- ▶ Change the network parameters of the device.
- ▶ Select **Industrial communication** > **Parameter**.
- ▶ Change the parameters.
- ▶ To update the parameters, restart the device.
- ✓ The device restarts.
- ✓ The network parameters of the device are changed.

## 6.8 Connect the functional earth

### **WARNING!**

Risk of ignition and risk of fire that are due to electrostatic discharge.

An electrostatic discharge of the device can ignite combustible gas vapours.

- ▶ To avoid a build up of electrostatic charge, connect the housing to the functional earth.
- ▶ If the functional earth is not attached, then the requirements of the EMC directive are not met.

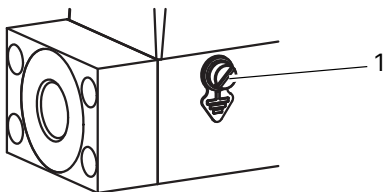

Fig. 14: Location of the M4 screw for the connection of the functional earth

1 M4 screw

- ▶ Use a green-and-yellow cable that is as short as possible. And the cable cross-section must be at least equal to the cross section of the power-supply cable.
- ▶ With a flat screwdriver of size 6.5 mm, loosen the M4 screw.
- ▶ Attach the green-and-yellow cable to the M4 screw with a cable lug.
- ▶ Tighten the M4 screw to a torque of 1,8 N·m...2 N·m (1,33 lbf·ft...1,47 lbf·ft).

## 7 Commissioning

---



Risk of injury or material damage when working on the device or system.

- ▶ Read and observe the chapter [Safety \[▶ 8\]](#) before working on the device or system.
- 

### 7.1 Commissioning procedure

- ▶ Pressurise the pipes with medium.
- ▶ Flush the pipes with medium at the calibration pressure.
- ▶ Vent the pipes completely.
- ▶ Check if the memory card is inserted.
- ▶ Energise the device.
- ▶ If the device is an MFC, and the medium is not the calibration medium or the pressure conditions have changed, then run the Autotune function. Refer to [Optimise the closed-loop control parameters \[▶ 52\]](#)
- ✓ The device operates normally.

## 8 Configuration with Bürkert Communicator

### 8.1 Setting tools



The MassFlowCommunicator is another PC software that is not compatible with the device. The MassFlowCommunicator software cannot be used to configure or operate the device.

Settings can be made with the Type 8920 Bürkert Communicator. For general information about the Bürkert Communicator, refer to the operating instructions of Type 8920.

- ▶ Access the page [Type 8920](#)
- ▶ Scroll down to **Downloads** > **User Manuals**

### 8.2 Connect to the Bürkert Communicator

[Analogue variant](#) | [Industrial Ethernet variant](#) | [PROFIBUS variant](#)

- ▶ Use the USB-büS-Interface set, article number 00772551.
- ▶ Download the latest version of the Type 8920 Bürkert Communicator.
- ▶ Access the page [Type 8920](#)
- ▶ Scroll down to **Downloads** > **Software**
- ▶ Install the Bürkert Communicator on a PC. During installation, the büS stick must not be connected to the PC.
- ▶ Assemble the parts of the USB-büS-Interface set.



Fig. 15: Assembled parts of the USB-büS-Interface set

- ▶ Set the termination-resistance switch of the büS stick to ON.
- ▶ Insert the büS stick into a USB port of the PC.
- ▶ Energise the device. Refer to [Electrical connection](#) [▶ 31]
- ▶ Insert the micro-USB connector into the büS interface of the device. Refer to [Product description](#) [▶ 11]
- ▶ Wait until the driver of the büS stick has been completely installed on the PC.
- ▶ Start the Bürkert Communicator.



- ▶ Click on  in the Bürkert Communicator to establish the communication with the device.

✓ A window opens.

- ▶ Select **Connect via USB (büs Stick)**.
- ▶ Select the port Bürkert USB büS stick, click on **Finish** and wait until the device symbol appears in the list of devices.
- ▶ In the navigation area, click on the symbol related to the device: The device menu appears.

### büs / CANopen variant

- ▶ Use the USB-büs-Interface set, article number 00772426.



Fig. 16: USB-büs-Interface set

---

1 büS stick with termination-resistance switch

---

- ▶ Download the latest version of the Type 8920 Bürkert Communicator.
- ▶ Access the page [Type 8920](#)
- ▶ Scroll down to **Downloads > Software**
- ▶ Install the Bürkert Communicator on a PC. During installation, the büS stick must not be connected to the PC.

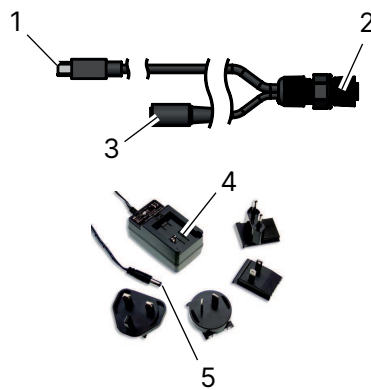



Fig. 17: Electrical connection parts of the USB-büs-Interface set

---

1 Micro-USB connector	2 5-pin M12 female connector
3 Jack female connector	4 AC/DC adapter
5 Jack male connector	

---

- ▶ Insert the micro-USB plug into the büS stick.
- ▶ Insert the appropriate power adapter into the AC/DC adapter.

- ▶ Connect the jack male-connector of the AC/DC-adapter cable to the jack female-connector of the M12 female-connector cable.
- ▶ Connect the M12 female connector to the bÜS network.
- ▶ If the device is connected to a bÜS network and is at a bÜS end, then set the bÜS stick switch to "ON". The termination resistance that is integrated in the bÜS stick is then activated.
- ▶ Insert the bÜS stick into a USB port of the PC.
- ▶ Wait until the Windows pilot of the bÜS stick has been completely installed on the PC.
- ▶ Connect the AC/DC adapter to the power supply.
- ▶ Start the Bürkert Communicator.
- ▶ Click on  in the Bürkert Communicator to establish the communication with the device.
  - ✓ A window opens.
- ▶ Select **Connect via USB (bÜS Stick)**.
- ▶ Select the port Bürkert USB bÜS stick, click on **Finish** and wait until the device symbol appears in the list of devices.
- ▶ In the navigation area, click on the symbol related to the device: The device menu appears.

## 8.3 Setting the Industrial Ethernet address

- ▶ To set the fieldbus address, use the Bürkert Communicator.
- ▶ Or use the man-machine interface of the PLC the device is connected to.
- ▶ If the address is changed and to avoid malfunction of the device, restart the device by turning off and on the power supply.

## 8.4 Functions

### 8.4.1 Shut-Off threshold for the valve

A shut-Off threshold ensures the sealing function of the control valve (except valve with PCTFE seat sealing). If the used set-point value is below the shut-off threshold, the control signal for the valve is set to 0% immediately.

### 8.4.2 Cut-Off threshold for actual flow

A cut-off threshold for the actual flow is calculated from the nominal flow, the measuring span and a calculation factor. Measured values below the calculated cut-off threshold will be displayed as zero actual flow.

### 8.4.3 Flush mode

#### Industrial Ethernet variant | PROFIBUS variant | bÜS / CANopen variant



MFC: If the integrated valve is fully open, the internal device temperature increases. If the internal device temperature increases, the device can be damaged.

- ▶ Do not let the valve fully open for more than 10 minutes.

To open the valve completely:

- ▶ Send an acyclic command to the device.
- ▶ Or send a cyclic command with the double nominal flow rate.

## 8.5 User-defined adjustment

At delivery the device is calibrated by the manufacturer.

With the Bürkert Communicator, it is possible to define an adjustment procedure with up to 32 calibration points.

This procedure is described in device specific **Documents and tools** in the Bürkert Communicator.

- ▶ Connect the device to the Bürkert Communicator. Refer to [Connect to the Bürkert Communicator \[▶ 45\]](#)

## 8.6 Zero point adjustment

It is possible to perform a zero point adjustment procedure to adapt the sensor characteristic curve to the current conditions (mounting/installation position, medium, operating pressure). The device will be calibrated in installation position in any case. It is possible to use another installation position. Afterwards a zero point adjustment procedure is necessary.

- ▶ Start the communication with the Bürkert Communicator. Refer to [Connect to the Bürkert Communicator \[▶ 45\]](#)
- ▶ Choose the device.
- ▶ Select **Sensor > Diagnostics > Start zero point adjustment**

✓ The procedure starts.

✓ The device switches the namur status to orange.

## 8.7 Set-point value sources and operation modes

### MFC

Different sources can set the process set-point value. Select one active source at a time.

Change the set-point value source during operation if required. Changing the set-point value source also changes the device operating mode.

When energising the device for the first time, the device enters a short initialisation phase and then switches to the normal operation mode.

- ▶ Connect the device to the Bürkert Communicator. Refer to [Connect to the Bürkert Communicator \[▶ 45\]](#).

- ▶ Select the device.
- ▶ Go to **Controller** > **Parameter** > **Set-point value** > **Set-point value source**.



The **Set-point value source** remains after a restart. It resets only when the selected source is **Manual set-point value** or **Analyze system**.

Set-point value source	Description	Operation mode
<b>Analog set-point value source</b> Only variant Analogue	The analogue input sets the set-point value	Normal operation mode (Closed Loop)
<b>Automatic</b> Only variant Industrial Ethernet	The fieldbus sets the set-point value. If several fieldbus participants simultaneously send values, the device uses the last received value.	Normal operation mode (Closed Loop)
<b>Manual set-point value</b>	For testing or to prevent overwriting by other fieldbus participants.	Normal operation mode (Closed Loop)
<b>Stored setpoint</b>	To use a fixed set-point value (w). After a device restart, the fixed set-point value remains active.	Normal operation mode (Closed Loop)
<b>Open-loop control mode</b>	To directly set the position set-point value (y) to the actuator.  The menu <b>Actuator</b> > <b>Parameter</b> > <b>Actuating variable</b> provides the used position set-point value (y). Restarting the device sets the position set-point value (y) to zero.	Open-loop control mode
<b>Analyze system</b>	The device operates in normal operation mode according to a predefined chronological sequence of set-point values. Use the resulting diagram with the graphical process values to analyse the system with the Bürkert Communicator.	Analyse the system

Tab. 18: Set-point value sources and operation modes

## 8.8 Increase the data transmission speed

### büS / CANopen variant

If the data transmission speed is increased, then the device provides more cyclic process-data.

For example, the actual value of the mass flow rate is available once every 100 ms by default. If the data transmission-speed is increased, then the actual value of the mass flow rate is available once every 10 ms.

- ▶ If the data transmission-speed is active simultaneously on several devices in the network, then make sure that the bus load does not exceed 50%.

To increase the data transmission-speed, do the following:

- ▶ Energise the bus network.

- ▶ Connect the device to the Bürkert Communicator software. Refer to [Connect to the Bürkert Communicator \[▶ 45\]](#)
- ▶ Move the PC mouse over the bus-stick symbol in the list of devices. If the bus load is higher than 45%, then do not increase the data transmission-speed.
- ▶ If the bus load is less than or equal to 45%, then the data transmission-speed can be increased. Do the following procedure:
  - ▶ Select the device.
  - ▶ Select **General settings** > **Parameter** > **PDO Configuration**.
  - ▶ To increase the data transmission-speed, change the inhibit time of the PDO to the desired value (min. 10 ms). Confirm the entry with **Apply and Save**.
    - ✓ The data transmission-speed is increased.
  - ▶ To go back to the default data transmission-speed, click **Reset to default values**.

## 8.9 Operation modes

### MFC

When energising the device for the first time, the device enters a short initialisation phase and then switches to the normal operation mode. Refer to [Normal operation mode \[▶ 50\]](#)

- ▶ To change the operation mode, change the source for the set-point values. Refer to [Select the source that gives the set-point value \[▶ 53\]](#)

The operation mode is kept after a device restart, except when the device performs the function **Analyze system**.

## 8.10 Normal operation mode

### MFC

The normal operation mode is active when energising the device for the first time.

#### MFC with proportional valve



If the valve seat seal is made of a hard material such as PCTFE, then the control valve may not be tight.

Valves with a seat size of 0.05 mm or 0.1 mm have a seat seal made of a hard material.

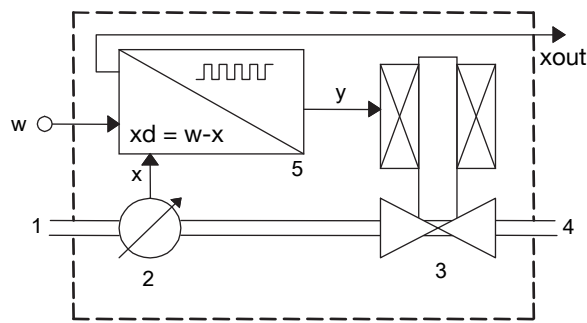

Fig. 18: Function diagram of the MFC with control valve

1 Medium inlet	2 Sensor
3 Control valve	4 Medium outlet
5 Electronics	x measured value of the mass flow rate
y set-point position of the valve	w set-point value of the mass flow rate

The sensor measures the mass flow rate and compares the measured value  $x$  with the set-point value  $w$ . The device calculates the set-point position value  $y$  of the actuator.

- The set-point position value  $y$  determines the opening of the control valve. For example, if the set-point position value  $y$  is equal to 10%, then the opening of the control valve is 10%.

The transmission means of the set-point value  $w$  and the measured value of the flow rate depends on the device.

- ▶ If the operating conditions have changed, then optimise the closed-loop control parameters. Refer to [Optimise the closed-loop control parameters \[▶ 52\]](#)
- ▶ To change the operation mode, change the source for the set-point value. Refer to [Select the source that gives the set-point value \[▶ 53\]](#)

### 8.10.1 Analogue variant

After applying the operating voltage, the device enters a short initialisation phase and then switches to the normal operation mode. The normal operation mode of a variant Analogue is the **Analog setpoint** operation mode.

- The set-point value  $w$  is transmitted over the set-point analogue input according to the ranges in the following table.
- The measured value of the flow rate is transmitted over the analogue output according to the ranges in the following table.

Analogue output range	Minimum value of the input ranges and output ranges	Maximum value of the input ranges and output ranges
4...20 mA	4 mA, $w = 0\%$	20 mA, $w = 100\%$
0...20 mA	0 mA, $w = 0\%$	20 mA, $w = 100\%$
0...5 V $\equiv$	0 V, $w = 0\%$	5 V, $w = 100\%$
0...10 V $\equiv$	0 V, $w = 0\%$	10 V, $w = 100\%$

Tab. 19: Analogue-input ranges and analogue-output ranges

## 8.10.2 Industrial Ethernet variant

After applying the operating voltage, the device enters a short initialisation phase and then switches to the **Automatic** operation mode.

- ▶ To change the control mode, i. e. to change the source for the set-point values. Refer to [Select the source that gives the set-point value \[▶ 53\]](#)
- ▶ To change the control parameters, use the Bürkert Communicator.

## 8.10.3 büS /CANopen variant

If the device detects that the pipe is empty, then the device cannot regulate.

After applying the operating voltage, the device enters a short initialisation phase and switches to the normal operation mode. The normal operation mode of a variant büS/CANopen is the **Automatic** operation mode. The set-point value is set via the fieldbus.

## 8.11 Optimise the closed-loop control parameters

### MFC

The closed-loop control parameters of the device can be optimised for the current operating conditions with a function that is called Autotune.

- Run the Autotune function when the device is started for the first time.
- If the operating conditions have changed, then run the Autotune function.

If the device detects that the pipe is empty, then the Autotune function cannot be started.

When the Autotune is running:

- ▶ Do not interrupt the power supply to the device.
- ▶ Keep the supply pressure constant.



### **WARNING!**

**Risk of injury from flowing medium.**

While the Autotune function is running, the mass flow rate value can be higher than the nominal flow rate value.

- ▶ Before running the Autotune function, make sure that no danger can occur if the mass flow rate value increases.
- ▶ Trigger the Autotune function with one of the following means:
  - ▶ over the fieldbus (variant büS/CANopen ),
  - ▶ over the fieldbus (variant Industrial Ethernet)
  - ▶ over the fieldbus (variant Profibus)
  - ▶ over the digital input (variant Analogue),
  - ▶ with the Bürkert Communicator. Refer to [Connect to the Bürkert Communicator \[▶ 45\]](#)
- ✓ The Autotune runs and the status indicator is orange.
- ✓ The device temporarily stops regulating the flow rate in the pipe.
- ✓ When the function is completed, the device returns to its previous operating mode.

- ✓ If the function is completed successfully, then the optimised closed-loop control parameters are transferred to the hard memory of the device.

## 8.12 Select the source that gives the set-point value

### MFC

The process set-point value can be set by different sources. It is possible to select which source is active at a time. The source for the set-point value can be changed during operation.

If the source for the set-point value is changed, then the operation mode of the device is changed.

To change the source for the set-point value, change the setting of the parameter **Set-point value source** with the Bürkert Communicator. Refer to [Connect to the Bürkert Communicator \[▶ 45\]](#)



The setting of the parameter **Set-point value source** is kept after a restart, except when the device performs the function **Analyze system** or the set-point value source was set to manual set-point.

### büS / CANopen variant | Industrial Ethernet variant | PROFIBUS variant

It is possible to alternatively change the related object. Refer to the file Device Description File.

- ▶ Access the page [Type 8746](#)
- ▶ Scroll down to **Downloads** > **Software**

## Possible choices for the parameter **Set-point value source**

Variant büS/CANopen: <b>Automatic</b>	The set-point value is set via the fieldbus.
Variant Analogue: <b>Analog set-point value source</b>	The setpoint value is set via the analogue input.
Variant Industrial Ethernet: <b>Automatic</b>	The set-point value is set via the fieldbus. If different fieldbus participants simultaneously specify a set-point value for the device, it is always the last set value that is used.
Variant Profibus: <b>Automatic</b>	The set-point value is set via the fieldbus.
<b>Manual set-point value</b>	To manually give in a set-point value for testing purposes or to make sure that the set-point value is not overwritten by other fieldbus participants.
<b>Stored setpoint</b>	To use a fixed set-point value (w). If the device is restarted, then the fixed set-point value remains active. Refer to <a href="#">Normal operation mode</a> [▶ 50]
<b>Open-loop control mode</b>	To directly set the set-point position (y) to the actuator. The value that is given in the menu <b>Actuator</b> > <b>Parameter</b> > <b>Actuating variable</b> is the setpoint position (y) that is used. A restart of the device sets the set-point position (y) to zero. Refer to <a href="#">Normal operation mode</a> [▶ 50]
<b>Analyze system</b>	The device operates in the normal operation mode, but according to a predefined chronological sequence with set-point values. Use the resulting diagram in combination with the graphical representation of process values to analyse the system with the Bürkert Communicator.

## 8.13 Set-point values without communication

### Industrial Ethernet variant | büS / CANopen variant | PROFIBUS variant

The function makes it possible to specify the set-point values of the device even if the communication with the external set-point value provider (for example a PLC) is broken. If the function is used, then the set-point is kept constant.



By using the function, the medium can continue to flow even if the communication is broken.

▶ Make sure the process is safe when the function is used.

- ▶ To use the function, refer to the file Device Description File.
- ▶ Access the page [Type 8746](#)
- ▶ Scroll down to **Downloads** > **Software**
- ▶ The configuration is available under **Controller** > **Parameter** > **Setpoint** > **Advanced settings** > **Connection abort behaviour**

## 8.14 Changing between bÜS and CANopen mode

### bÜS / CANopen variant

To select the different digital communication modes (bÜS or CANopen), use the software Bürkert communicator.

- ▶ Connect the device to the Bürkert Communicator software. Refer to [Connect to the Bürkert Communicator \[▶ 45\]](#)
- ▶ Select the device.
- ▶ Select **General settings** > **Parameter** > **bÜS** > **Advanced** > **Bus mode**
- ▶ Select the operating mode of the digital communication.
- ▶ Restart the device.
- ✓ The operating mode of the fieldbus is changed.
- ✓ If the operating mode of the fieldbus is bÜS, the **CANopen status** is set to **Operational** and the PDO's are sent to bÜS.
- ✓ If the operating mode of the fieldbus is CANopen, the **CANopen status** is set to **Pre-Op** until the CANopen network master switches the device to **Operational**.

## 9 Maintenance

If the device is operated according to the Operating instructions, then the device is maintenance-free.



Risk of injury or material damage when working on the device or system.

- ▶ Read and observe the chapter [Safety \[▶ 8\]](#) before working on the device or system.

### 9.1 Service tasks and intervals

The device is equipped with a stainless steel mesh-filter, which is located in the medium connection. If the device is exposed to a demanding environment or contaminated medium, the filter must be checked regularly. If necessary, the filter can be cleaned.

### 9.2 Inspect and clean the stainless steel mesh-filter

The inspection and possibly cleaning of the stainless steel meshfilter must be done at regular intervals. The inspection frequency and cleaning frequency depend on the measured medium.

If a contaminated medium is used, then clean the stainless steel mesh-filter immediately. If the stainless steel mesh-filter is contaminated, then replace it with a new one.

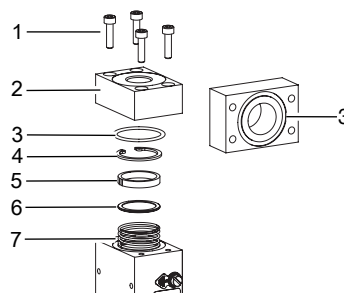

Fig. 19: Parts in contact with the medium

1 Screws	2 Flange plate
3 O-ring	4 Circlip
5 Ring	6 Stainless steel mesh-filter
7 Compression spring	

- ▶ Position the device upright with the medium inlet at the top.
- ▶ With an hexagon key of size 3 mm, loosen the screws [1] and remove the flange plate [2]. The O-ring [3] remains in the groove on the rear side of the flange plate.
- ▶ With a pair of tweezers, carefully remove the circlip [4] because the mesh filter [6] and the ring [5] will be pushed out by the compression spring [7].
- ▶ **CAUTION! Do not clean the mesh filter with tap water.** Clean the stainless steel mesh-filter [6] with acetone, isopropanol or compressed air.
- ▶ Dry the mesh filter.

- ▶ **CAUTION! Before mounting the parts back, make sure that the fine side of the mesh filter [6] faces the flange plate [2]**
- ▶ Push back the compression spring [7] together with the mesh filter [6] into the base block and secure them with the circlip [4].
- ▶ Make sure that the mesh filter and the O-ring are seated flat and not tilted.
- ▶ Insert the flange plate [2] and the screws [1].
- ▶ Tighten the screws to a torque of 2.8 N·m (2.06 lbf·ft).

## 9.3 Calibration

The device is factory calibrated.

A regular check of the accuracy depends on the use and the individual requirements of the application. Mechanical wear, ageing of the materials, temperature changes, frequent use or contamination can affect the measuring accuracy over time. It is therefore advisable to calibrate measuring devices regularly to ensure precise measurement results at all times. The customer is responsible for determining the timing of the periodic inspection. We recommend checking the calibration after 12 months. If required, contact [Bürkert](#) for further information on calibrations and to arrange an appointment.



The calibration only applies to the primary measuring function of the measuring device. The secondary outputs are not covered by the calibration.

## 9.4 Replace the memory card

### Analogue variant | Industrial Ethernet variant | PROFIBUS variant

- ▶ De-energise the device.
- ▶ With a TX8 screwdriver loosen the screws of the cover. Remove the cover.

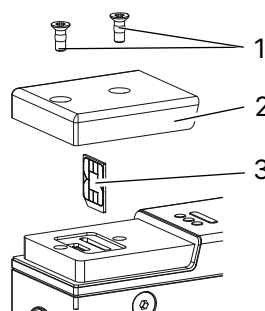

Fig. 20: Insertion direction of the memory card

- |                                                              |         |
|--------------------------------------------------------------|---------|
| 1 Screws                                                     | 2 Cover |
| 3 Memory card: make sure the insertion direction is correct. |         |

- ▶ Remove the old memory card from its slot.
- ▶ Pay attention to the insertion direction of the memory card.

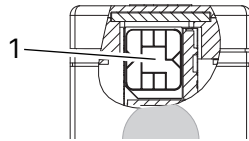

Fig. 21: Cross-sectional drawing

---

1 Inserted memory card

---

- ▶ With a TX8 screwdriver, screw the cover to a torque of 1.2 N·m (0.9 lbf·ft).
- ▶ Restart the device to write the data on the new memory card. Possible problems related to the memory card are given in Troubleshooting

### büS / CANopen variant

- ▶ De-energise the device.
- ▶ With a 2.5-mm hex key, loosen the screws of the impact protection-cover and remove the impact protection-cover.
- ▶ Loosen and remove the wired 5-pin female connector.
- ▶ With a T30 hexalobular-internal screwdriver, open the blind plug.
- ▶ Remove the old memory card from its slot.
- ▶ Pay attention to the insertion direction of the memory card.

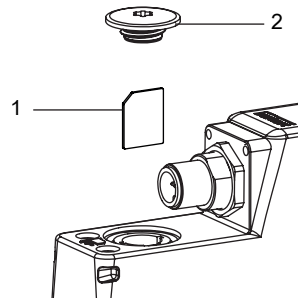

Fig. 22: Insertion direction of the memory card

---

1 Memory card

2 Blind plug

---

- ▶ Grip the memory card with flat nose pliers and insert the memory card at an angle. Apply pressure to overcome the counter force of the spring contact.

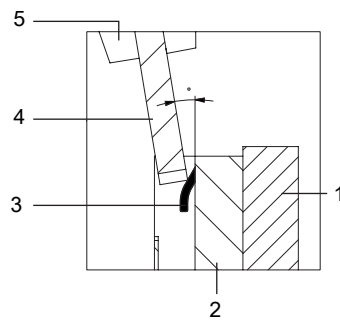

Fig. 23: Insertion of the memory card with flat-nose pliers

1 Electronic board	2 Holder of the memory card
3 Contact spring	4 Memory card
5 Flat-nose pliers	

- ▶ After overcoming the force of the spring, insert the memory card vertically.
- ▶ With a T30 hexalobular-internal screwdriver, screw the blind plug to a torque of 2 N·m (1.47 lbf·ft).
- ▶ Screw the wired 5-pin female connector.
- ▶ With a 2.5-mm hex key, screw back the impact protection-cover.
- ▶ Restart the device to write the data on the new memory card. Possible problems related to the memory card are given in [Troubleshooting \[▶ 60\]](#)

### büS / CANopen variant

The büS/CANopen variant supports the config-client if no memory card is used.

- ▶ Activate this functionality in the Bürkert communicator under **General settings > Parameter > Act as a configuration client > Yes**.

For detailed information, refer to the "Software manual | Central configuration management".

- ▶ Access the page [Type 8746](#)
- ▶ Scroll down to **Downloads > User Manuals**

## 10 Troubleshooting

### 10.1 Status indicator is red

Cause	Solution
The supply voltage is out of the error range. The device can be damaged.	<ul style="list-style-type: none"> <li>▶ Operate the device within the specifications.</li> </ul> <p>If the status indicator does not change, then send the device back to Bürkert.</p>
The sensor, the internal memory or the device is defective.	<p>Maintenance is needed.</p> <ul style="list-style-type: none"> <li>▶ Contact the manufacturer.</li> </ul>
<b>Industrial Ethernet variant   PROFIBUS variant</b>	
No proper connection to the PLC.	<ul style="list-style-type: none"> <li>▶ Check the wiring.</li> <li>▶ Check the status of the PLC.</li> </ul>
<b>EtherCAT variant</b>	
	<ul style="list-style-type: none"> <li>▶ If the EtherCAT protocol is used, make sure the incoming cable (reception from the PLC) is inserted in the ETH1 port and the outgoing cable is inserted in the ETH2 port.</li> </ul>
<b>büS / CANopen variant</b>	
büS error or CANopen-bus error, for example a short circuit.	<ul style="list-style-type: none"> <li>▶ Check the wiring.</li> </ul>
<b>büS / CANopen variant</b>	
The device is connected to büS, but cannot find any fieldbus participants.	<ul style="list-style-type: none"> <li>▶ Check the wiring.</li> <li>▶ Operate the device with other fieldbus participants.</li> </ul>
<b>büS / CANopen variant</b>	
The device is connected to büS, but does not find the process value to be processed.	<ul style="list-style-type: none"> <li>▶ Make sure that the process value is correctly allocated.</li> <li>▶ Check the assigned büS participant that is defective.</li> <li>▶ Make sure that the assigned büS participant provides the cyclic data.</li> </ul>
<b>MFC</b>	
Incorrect Autotune or Autotune aborted. After a restart of the device, the error will be reset.	<ul style="list-style-type: none"> <li>▶ Make sure that the medium flows through the device.</li> <li>▶ Check the <math>Q_{nom}</math> of the device.</li> <li>▶ Start the Autotune again.</li> </ul> <p>After a restart of the device, the error will be reset.</p>

## 10.2 Status indicator is orange

Cause	Solution
A calibration procedure is in progress.	▶ Wait until the procedure is completed.
<b>büS / CANopen variant</b>	
The device is connected to büS and searches assigned fieldbus participant.	▶ Wait until the device has found assigned fieldbus participants.
<b>büS / CANopen variant</b>	
The device is connected to büS and is configured manually, but has no address.	▶ Wait up to one minute until the device assigns its address.
<b>PROFINET variant</b>	
PLC is in Stop mode.	▶ Activate the PLC.
<b>MFC</b>	
The Autotune is in progress.	▶ Wait until the procedure is completed.
<b>MFC</b>	
The operation mode of the device is set to <b>Open-loop control mode</b> , <b>Manual set-point value</b> or <b>Analyze system</b> .	Refer to <a href="#">Select the source that gives the set-point value</a> [▶ 53]

## 10.3 Status indicator is yellow

Cause	Solution
One of the following values is out of specification. The sensor or the device can be damaged. <ul style="list-style-type: none"> <li>• the medium temperature</li> <li>• the device temperature</li> <li>• the supply voltage</li> </ul>	▶ Operate the device within the specifications. If the status indicator does not change, then send the device back to Bürkert.
<b>büS / CANopen variant</b>	
Other fieldbus participants use the same node ID.	▶ Assign an individual node ID to each fieldbus participant.
<b>Industrial Ethernet variant</b>	
A change of the Ethernet protocol is in progress.	▶ Wait until the procedure is completed.

Cause	Solution
<b>MFC</b>	
The set-point position for the actuator has (almost) reached 100%. The set-point value cannot be reached.	▶ Increase the inlet pressure or decrease the output pressure.
	▶ If the pressure drop in the pipe is too high, then reduce the pressure drop.
	▶ If the filters installed in the pipe are dirty, then clean the filters.

## 10.4 Status indicator is blue

Cause	Solution
Error in the internal memory.	Maintenance is needed. ▶ Contact the manufacturer.

## 10.5 Status indicator is off

Cause	Solution
The device is not energised.	▶ Check the wiring.
	▶ Make sure that the voltage supply is 24 V $\overline{\text{---}}$ .
	▶ Make sure that the power supply source is working properly.

## 10.6 Status indicator goes out periodically

Cause	Solution
The power supply is intermittently dropping and the device restarts.	▶ Use a power supply with sufficient power output.
The voltage drop in the connecting cable is too high.	▶ Increase the cross-section of the cable and reduce the cable length.

## 10.7 Replacement device adopts none of the values from the defective device

Cause	Solution
The article number of the replacement device is different from the article number of the defective device.	▶ Use a replacement device that has the same article number than the defective device.
	Values can only be transferred between devices with the same article numbers.

Cause	Solution
The memory card is defective. The device could not write any values to the memory card.	<ul style="list-style-type: none"> <li>▶ Replace the memory card.</li> </ul> Refer to <a href="#">Replace the memory card [▶ 57]</a> .

## 10.8 Replacement device does not adopt all of the values from the defective device

Cause	Solution
The device description of the replacement device is different from the device structure of the defective device. Only the existing values of the defective device can be adopted by the replacement device.	<ul style="list-style-type: none"> <li>▶ Use the Bürkert Communicator to configure the new values of the replacement device.</li> </ul>

## 10.9 No mass flow rate

Cause	Solution
The pipes are too large or not yet fully vented.	<ul style="list-style-type: none"> <li>▶ Vent the pipe.</li> <li>▶ Change the pipe diameter.</li> </ul>
The flow-rate value is below the cut-off limit.	<ul style="list-style-type: none"> <li>▶ If the cut-off limit is too high, decrease the value of the cut-off limit.</li> </ul> Refer to Cut-off.

### MFC

The device is not in the normal operation mode, refer to [Operation modes \[▶ 50\]](#).

The device is possibly running one of the functions described in [Select the source that gives the set-point value \[▶ 53\]](#)

- ▶ If the device is not running one of the functions described in [Select the source that gives the set-point value \[▶ 53\]](#), then check the other possible causes of the problem.

### MFC

The set-point value is lower than the zero-point shut-off limit.

- ▶ Increase the set-point value until it is higher than 2% of the nominal flow rate.

## 10.10 Unstable measured value

Cause	Solution
Functional earth (FE) is not connected properly.	<ul style="list-style-type: none"> <li>▶ To connect the functional earth, use a green-and-yellow cable that is as short as possible.</li> </ul> <p>the cable cross-section must be at least equal to the cross section of the power-supply cable. Refer to <a href="#">Connect the functional earth [▶ 43]</a></p>
<b>MFC</b>	
The residual ripple on the voltage supply is too high.	<ul style="list-style-type: none"> <li>▶ Use a supply voltage that conforms to the technical data given in <a href="#">Technical data [▶ 18]</a></li> </ul>
<b>MFC</b>	
The device must compensate for irregularities in an unstable pressure supply caused, for example, by pumps.	<ul style="list-style-type: none"> <li>▶ Install a suitable pressure regulator in front of the device.</li> <li>▶ Install a buffer tank to absorb the pressure fluctuations.</li> </ul>
<b>MFC</b>	
The controller is unstable.	<ul style="list-style-type: none"> <li>▶ Run the Autotune function to adapt to the operating conditions.</li> </ul>

## 10.11 Set-point value at 0 %, but medium still flows

Cause	Solution
<b>MFC with proportional valve</b>	
The connected actuator is a proportional valve and the operating pressure is above the tight sealing pressure of the proportional valve.	<ul style="list-style-type: none"> <li>▶ Reduce the operating pressure.</li> <li>▶ To eliminate the defect, return the device to the manufacturer.</li> </ul>
<b>MFC Analogue</b>	
The operating mode of the device is set to <b>Open-loop control mode</b> , and the actuator is open because the digital input triggers the opening of the actuator.	<ul style="list-style-type: none"> <li>▶ Set the device to the normal operating mode.</li> </ul> <p>Refer to Normal operating mode (MFC) and to <a href="#">Select the source that gives the set-point value [▶ 53]</a>.</p> <ul style="list-style-type: none"> <li>▶ Check the operation of the digital input.</li> </ul> <p>Refer to Digital input</p>

## 10.12 Set-point value at 0 %, no mass flow, but a non-zero mass flow rate is measured

Cause	Solution
<b>MFC</b>	
The installation position of the device is incorrect.	<ul style="list-style-type: none"> <li>▶ Install the device as recommended in <a href="#">Medium connection [▶ 29]</a></li> <li>▶ Run the Autotune function to adapt to the operating conditions.</li> <li>▶ Run a zero point adjustment.</li> </ul> Refer to <a href="#">Zero point adjustment [▶ 48]</a>
<b>MFC</b>	
The medium is different from the medium specified during the calibration.	<ul style="list-style-type: none"> <li>▶ Use the specified medium or send the device to the manufacturer for calibration with the new medium.</li> </ul>

## 10.13 Set-point value is not reached

Cause	Solution
<b>MFC</b>	
The mesh filter is clogged.	<ul style="list-style-type: none"> <li>▶ Clean or replace the mesh filter.</li> <li>▶ Run the Autotune function to adapt to the operating conditions.</li> </ul>
<b>MFC with proportional valve</b>	
The outlet pressure is too high.	<ul style="list-style-type: none"> <li>▶ Make sure that the pipe diameters and the pipe lengths are adapted.</li> <li>▶ If the medium connection pipes after the device are dirty, then clean them.</li> </ul>
<b>MFC with proportional valve</b>	
The inlet pressure is too low.	<ul style="list-style-type: none"> <li>▶ Increase the inlet pressure to the calibration pressure value.</li> <li>▶ Make sure that the pipe diameters and the pipe lengths are adapted.</li> </ul>

## 10.14 Network status indicator

LED indicator	Meaning	Action
Link/Act-LED (green) fast blinking	Connection to the parent protocol layer is established.	-
Link/Act-LED (green) slow blinking (directly after restart)	Connection to the protocol layer is searched.	-
Link/Act-LED (green) slow blinking (20 s after restart)	No connection to the parent protocol layer.	▶ Check the cable.
Link/Act-LED (green) is OFF.	No connection to the network.	▶ Check the cable.
Link-LED (yellow) is ON	Connection to the network is established.	-
Link LED (yellow) is not lit	Not connected to network.	▶ Check cable.

Tab. 20: Meaning of the LED indicator

# 11 Uninstallation

## 11.1 Dismantling

- ▶ Relieve the medium pressure in the installation.
- ▶ Flush the device with a neutral medium (for example nitrogen)
- ▶ Relieve the flushing medium pressure in the installation.
- ▶ De-energise the device.
- ▶ Remove the electrical wiring.
- ▶ Disconnect the medium connections.
- ▶ Remove the device.

## 12 Spare parts and accessories



Risk of injury and/or damage due to incorrect parts.

- ▶ Use only original accessories and original spare parts from Bürkert.



Order the parts directly on our [eShop](#).

### 12.1 Electrical accessories

- ▶ For further accessories, refer to the data sheet.

#### Analogue variant

USB-büS-interface set, without power supply	772551
Straight 5-pin M12 female connector	772416
Straight 5-pin M12 male connector	772417
Bent 5-pin M12 female connector	772418
Memory card	on request
Connection cable with M12 male connector (A-coded) and free cable end, 5 m	566923
Connection cable with M12 male connector (A-coded) and free cable end, 10 m	571393
Connection cable with M12 female connector (A-coded) and free cable end, 5 m	560365
Connection cable with M12 female connector (A-coded) and free cable end, 10 m	563108

#### Industrial Ethernet variant

USB-büS-interface set, without power supply	772551
Straight 5-pin M12 female connector	772416
Bent 5-pin M12 female connector	772418
Memory card	on request
Connection cable with M12 female connector (A-coded) and free cable end, 5 m	560365
Connection cable with M12 female connector (A-coded) and free cable end, 10 m	563108
Adapter M8 - M12 D coded	576314

**Type 8746**

Spare parts and accessories

**PROFIBUS variant**

USB-büS-interface set, without power supply	772551
Straight 5-pin M12 female connector	772416
Bent 5-pin M12 female connector	772418
Memory card	on request
Connection cable with M12 female connector (A-coded) and free cable end, 5 m	560365
Connection cable with M12 female connector (A-coded) and free cable end, 10 m	563108
Straight 5-pin M12 male connector (B coding)	918198
Profibus Y-piece	902098
Profibus T-piece	918531
Straight 5-pin M12 female connector (B coding)	918447
Profibus termination resistor, male connector (B coding)	902553

**büS / CANopen variant**

USB-büS-interface set, including power supply	772426
büS cable, 50 m	772413
büS cable, 100 m	772414
Straight 5-pin M12 female connector	772416
Bent 5-pin M12 female connector	772418
Y junction	772420
Y junction for connecting 2 separately energised segments of a büS network	772421
5-pin M12 male connector with 120-Ohm termination resistor	772424
5-pin M12 female connector with 120-Ohm termination resistor	772425
Memory card	on request
büS extension cable with 5-pin M12 connectors, 0.1 m	772492
büS extension cable with 5-pin M12 connectors, 0.2 m	772402
büS extension cable with 5-pin M12 connectors, 0.5 m	772403
büS extension cable with 5-pin M12 connectors, 1 m	772404
büS extension cable with 5-pin M12 connectors, 3 m	772405

## 12.2 Compression fittings for a device with G-internal-threaded connections

The threaded pipe-connection plates of the device obey standard DIN ISO 228/1. If the pipe fittings are not delivered with the device, then choose pipe fittings that are adapted to the medium connection of the device. Also order the seal depending on the medium connection and the pipe diameter.

Device internal-threaded connection in accordance with DIN ISO 228/1	Pipe diameter	Article number	
		Stainless steel compression-fitting	Seal (1 piece)
G 1/4	6 mm	901538	901575 (Copper)
G 1/4	8 mm	901540	
G 1/4	1/4"	901551	901579 (Rubber steel)
G 1/4	3/8"	901553	

Tab. 21: Stainless steel compression fittings and related seals

## 12.3 Additional software

Bürkert Communicator	Download from <a href="https://country.burkert.com">country.burkert.com</a>
----------------------	-----------------------------------------------------------------------------

Tab. 22: Documentation and software

## 13 Logistics

### 13.1 Transport and storage

- ▶ Protect the device against moisture and dirt in the original packaging during transportation and storage.
- ▶ Avoid UV radiation and direct sunlight.
- ▶ Protect connections, if present, from damage with protective caps.
- ▶ Observe the permitted storage temperature.
- ▶ Remove cables, connectors, external filters and installation equipment.
- ▶ Clean and vent contaminated devices.

### 13.2 Return



---

No work or tests will be carried out on the device until a valid Contamination Declaration has been received.

---

- ▶ To return a used device to Bürkert, contact the Bürkert sales office. A return number is required.

### 13.3 Disposal

Environmentally friendly disposal



- ▶ Follow national regulations regarding disposal and the environment.
- ▶ Collect electrical and electronic devices separately and dispose of them as special waste.

Further information at [country.burkert.com](https://country.burkert.com)