

Type 8741

Mass flow controller (MFC)/mass flow meter (MFM) for gases



Operating Instructions

We reserve the right to make technical changes without notice.

© Bürkert SAS 2017-2026

Technical documentation 2603/07_GBen_00568707_517166091_1163417227 / Original EN

Table of contents

1	About this document	6
1.1	Symbols	6
1.2	Terms and abbreviations	7
1.3	Manufacturer	7
2	Safety	8
2.1	Intended use	8
2.2	Safety instructions	8
3	Product description	11
3.1	Product overview	11
3.2	Product identification	15
3.2.1	Type label	15
3.2.2	Calibration label	16
3.2.3	Conformity marking	16
3.2.4	Symbols and markings on device	16
3.3	Display elements	16
3.3.1	Status indicator	16
3.3.2	NAMUR mode	18
3.3.3	Network status indicator	18
3.3.4	Communication indicator	19
3.4	Functionality	19
3.4.1	Service-büS interface	19
3.4.2	Control valve	19
3.4.3	Memory card	20
4	Technical data	21
4.1	Standards and directives	21
4.2	Operating conditions	21
4.3	Medium data	22
4.3.1	Pressure loss	23
4.4	Electrical data	25
4.5	Communication	28
4.5.1	Industrial Ethernet: EtherCAT	28
4.5.2	Industrial Ethernet: EtherNet/IP	29
4.5.3	Industrial Ethernet: Modbus TCP	29
4.5.4	Industrial Ethernet: PROFINET IO	29
4.6	Mechanical data	30
5	Medium connection	31
5.1	Possible medium connections	31
5.2	Installation procedure	31
5.2.1	G1/8"-internal-threaded connections	31
5.2.2	NPT1/8"-internal-threaded connections	31
5.2.3	Flange connections	32
5.2.4	Connections with external-threaded vacuum fittings	32
5.2.5	Connections with external-threaded compression fittings	32
5.2.6	Tri-clamp connections	32
6	Electrical connection	33

6.1	Additional documentation	33
6.2	Wire the variant bÜS /CANopen	33
6.2.1	With bÜS extension cables from Bürkert	33
6.2.2	With bÜS cables from Bürkert	33
6.2.3	With CANopen cables	34
6.3	Wire the variant Analogue with D-sub DE-9 male connector	35
6.3.1	Digital input	37
6.3.2	Relay output	39
6.4	Wire the variant Analogue with a 6-pin terminal strip	40
6.5	Wire the variant Industrial Ethernet	41
6.6	Change the network parameters	42
6.6.1	Over the product web server	43
6.6.2	Over the Bürkert Communicator software	43
6.7	Wire the variant RS485/Modbus RTU	44
6.8	Connect the functional earth	45
7	Commissioning	46
7.1	Commissioning procedure	46
8	Configuration with Bürkert Communicator	47
8.1	Setting tools	47
8.2	Connect to the Bürkert Communicator	47
8.3	Setting the Industrial Ethernet address	49
8.4	Functions	49
8.4.1	Shut-Off threshold for the valve	49
8.4.2	Cut-Off threshold for actual flow	49
8.4.3	Flush mode	50
8.5	User-defined adjustment	51
8.6	Zero point adjustment	51
8.7	Set-point value sources and operation modes	51
8.8	Increase the data transmission speed	52
8.9	Operation modes	53
8.10	Normal operation mode	53
8.10.1	Analogue variant	54
8.10.2	Industrial Ethernet variant	54
8.10.3	bÜS /CANopen variant	54
8.11	Optimise the closed-loop control parameters	55
8.12	Select the source that gives the set-point value	55
8.13	Set-point values without communication	56
8.14	Changing between bÜS and CANopen mode	57
9	Maintenance	58
9.1	Service tasks and intervals	58
9.2	Inspect and clean the stainless steel mesh-filter	58
9.3	Calibration	59
9.4	Replace the memory card	59
10	Troubleshooting	62
10.1	Status indicator is red	62
10.2	Status indicator is orange	63
10.3	Status indicator is yellow	63
10.4	Status indicator is blue	64

10.5	Status indicator is off	64
10.6	Status indicator goes out periodically	64
10.7	Replacement device adopts none of the values from the defective device	64
10.8	Replacement device does not adopt all of the values from the defective device	65
10.9	No mass flow rate	65
10.10	Unstable measured value	66
10.11	Set-point value at 0 %, but medium still flows	66
10.12	Set-point value at 0 %, no mass flow, but a non-zero mass flow rate is measured	67
10.13	Set-point value is not reached	67
10.14	Network status indicator	68
11	Uninstallation	69
11.1	Dismantling	69
12	Spare parts and accessories	70
12.1	Electrical accessories	70
12.2	Compression fittings for a device with G-internal-threaded connections	71
12.3	Additional software	71
13	Logistics	72
13.1	Transport and storage	72
13.2	Return	72
13.3	Disposal	72

1 About this document

The document is an important part of the product and guides the user to safe installation and operation. The information and instructions in this document are binding for the use of the product.

- ▶ Before using the product for the first time, read and observe the whole safety chapter.
- ▶ Before starting any work on the product, read and observe the respective sections of the document.
- ▶ Keep the document available for reference and give it to the next user.
- ▶ Contact the Bürkert sales office for any questions.



Further information concerning the product at [Products](#).

- ▶ Enter the article number from the type label in the search bar.

The illustrations in these instructions may vary depending on the product variant.

1.1 Symbols



DANGER!

Warns of a danger that leads to death or serious injuries.



WARNING!

Warns of a danger that can lead to death or serious injuries.



CAUTION!

Warns of a danger that can lead to minor injuries.

NOTICE!

Warns of property damage on the product or the installation.



Indicates important additional information, tips and recommendations.



Refers to information in this document or in other documents.

- ▶ Indicates a step to be carried out.

✓ Indicates a result.

Menu Indicates a software user-interface text.

1.2 Terms and abbreviations

The terms and abbreviations are used in this document to refer to following definitions.

Device	Type 8741
MFM	Mass flow meter
MFC	Mass flow controller
büS	Bürkert system bus, a communication bus developed by Bürkert and based on the CANopen protocol
bar, bar (g)	Unit for relative pressure
bar abs	Unit for absolute pressure
Ex area	Potentially explosive atmosphere
Ex approval	Approval for potentially explosive atmosphere

1.3 Manufacturer

Bürkert SAS

20, rue du Giessen

67220 TRIEMBACH-AU VAL

FRANCE

The contact addresses are available at [Contact](#).



Need more information or additional products?

► Explore the full range of products on our [eShop](#).

2 Safety

2.1 Intended use

The device MFM is designed to measure the mass flow rate of clean and dry gases.

The device MFC is designed to measure and regulate the mass flow rate of clean and dry gases.

The permitted media are listed in [Technical data \[▶ 21\]](#).

Prerequisites for safe and trouble-free operation are proper transport, storage, installation, commissioning, operation and maintenance.

The instructions are part of the device. The device is intended exclusively for use within the scope of these instructions. Uses of the device that are not described in these instructions, the contractual documents or the type label can lead to severe personal injury or death, damage to the device or property and dangers for the surrounding area or the environment.

- ▶ Only trained and qualified personnel may install, operate and maintain the device. See qualification of persons in [Safety instructions \[▶ 8\]](#)
- ▶ Use the device only in conjunction with third-party devices and components recommended and authorized by Bürkert.
- ▶ Use the device only when it is in perfect condition.
- ▶ Only use the device indoors.
- ▶ Only use devices that are approved for this type of potentially explosive atmosphere. These devices are labelled with the ATEX label on the type label. When using, always observe the details on the type label and the instructions for the potentially explosive atmosphere included in the scope of delivery for the device.
- ▶ Do not open the device.
- ▶ Do not use the device in high-vibration areas.

2.2 Safety instructions

Qualification of personnel working with the device

Improper use of the device can lead to serious personal injury or death. To avoid accidents when working with the device, the following minimum requirements must be met:

- ▶ Carry out work on the device within the scope of these instructions in a safety-compliant manner.
- ▶ Detect and avoid dangers when working on the device.
- ▶ Understand the instructions and implement the information contained therein accordingly.

Responsibility of the operator

The operator is responsible for observing the location-specific safety regulations, also in relation to personnel.

- ▶ Observe the general rules of technology.
- ▶ Install the device according to the regulations applicable in the respective country.
- ▶ The operator must make hazards arising from the location of the device avoidable by providing appropriate operating instructions.

Electrostatically sensitive components and assemblies

The device contains electronic components that are susceptible to the effects of electrostatic discharging (ESD). Components that come into contact with electrostatically charged persons or objects are at risk. In the worst case scenario, these components will be destroyed immediately or fail after start-up.

- ▶ Meet the requirements specified by EN 61340-5-1 to minimise or avoid the possibility of damage caused by a sudden electrostatic discharge.
- ▶ Do not touch electronic components when the supply voltage is connected.

Electric shock due to electrical components

Touching live parts can result in severe electric shock. This can lead to serious personal injury or death.

- ▶ Before working on the device or system, switch off the power supply. Secure it against reactivation.
- ▶ Observe any applicable accident prevention and safety regulations for electrical devices.

Changes and other modifications, spare parts and accessories

Changes to the device, incorrect installation or use of non-approved devices or components create hazards that can lead to accidents and injuries.

- ▶ Do not make any changes to the device.
- ▶ Do not mechanically load the device.
- ▶ Observe the operating instructions of the device or component used.
- ▶ Only use the devices in conjunction with devices and components recommended or approved by Bürkert.

Spare parts and accessories that do not meet Bürkert's requirements may impair the operational safety of the device and cause accidents.

- ▶ To ensure operational safety, only use original parts from Bürkert.

Operation only after proper transport, storage, installation, commissioning, or maintenance

Improper transport, storage, installation, commissioning, or maintenance jeopardises the operational safety of the device and can cause accidents. This can lead to serious personal injury or death.

- ▶ Observe all values and limits specified in these instructions to ensure the device's safety and functionality.
- ▶ Only carry out work described in these instructions.
- ▶ Only carry out work using suitable tools.
- ▶ All other work must be carried out by Bürkert only.

Working on the device

Working on the device that has not been powered down, unauthorised switching on or uncontrolled start-up of the system can cause accidents. This can lead to serious personal injury or death.

- ▶ Only work on the device when it is not in use.
- ▶ Ensure that the device or system cannot be switched on unintentionally.

- ▶ Only start the process in a controlled manner following disruptions. Observe sequence:
 1. Apply supply voltage or pneumatic supply.
 2. Charge the device with medium.

Technical limit values and media

Non-compliance with technical limit values or unsuitable media can damage the device and lead to leaks. This can cause accidents and seriously injure or kill people.

- ▶ Comply with limit values. See **Technical data** [▶ 21] and information on the type label.
- ▶ Only feed media into the media ports that are listed in the chapter **Technical data** [▶ 21].
- ▶ Observe the safety data sheet for the media used.

Only use authorised devices in potentially explosive atmospheres

Devices that may be used in potentially explosive atmospheres are labelled with an Ex marking. Additional instructions with Ex labelling are included with these devices.

- ▶ Only use devices that are approved for use in a potentially explosive atmosphere.
- ▶ For use in potentially explosive atmospheres, observe the information on the device.
- ▶ For use in potentially explosive atmospheres, observe the additional instructions with Ex labelling.
- ▶ Do not use devices that do not have this Ex labelling and additional instructions in potentially explosive atmospheres under any circumstances.

Medium under pressure

Medium under pressure can seriously injure people. In the event of overpressure or pressure surges, the device or lines can burst. Pneumatic lines that are defective or not securely fastened can come loose and swing around.

- ▶ Before working on the device or system, switch off the pressure. Vent or empty the lines.
- ▶ Adhere to the permitted pressure ranges of the medium.
- ▶ Comply with the permitted temperature ranges of the medium.

Hot surfaces and fire hazard

The surface of the device can become hot with fast-switching actuators or with hot media.

- ▶ Wear suitable protective gloves.
- ▶ Keep highly flammable substances and media away from the device.

3 Product description

3.1 Product overview

MFM Analogue

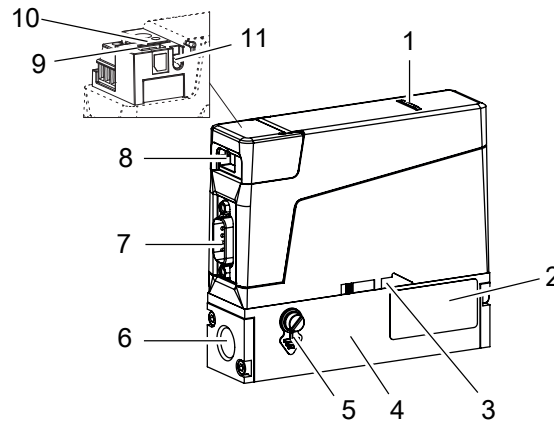

Fig. 1: Example of a variant MFM Analogue

1 Status indicator	2 Type label
3 Flow direction marking	4 Base block
5 Functional earth connection	6 Medium connection
7 Electrical connection	8 Not used
9 büS interface	10 Slot for memory card
11 Not used	

MFM Industrial Ethernet

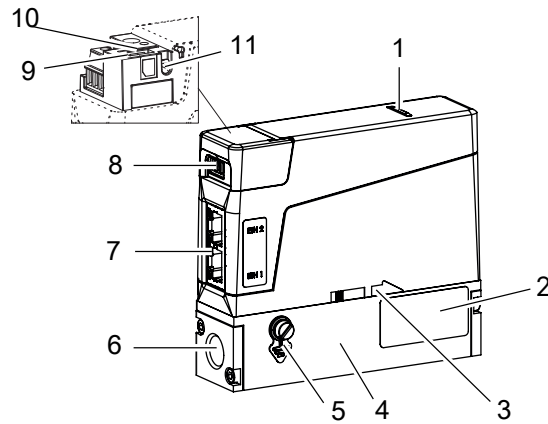

Fig. 2: Example of a variant MFM Industrial Ethernet

1 Status indicator	2 Type label
3 Flow direction marking	4 Base block
5 Functional earth connection	6 Medium connection
7 Electrical connection	8 3-pin removable terminal strip
9 büS interface	10 Slot for memory card
11 Communication indicator	

MFM büS/CANopen

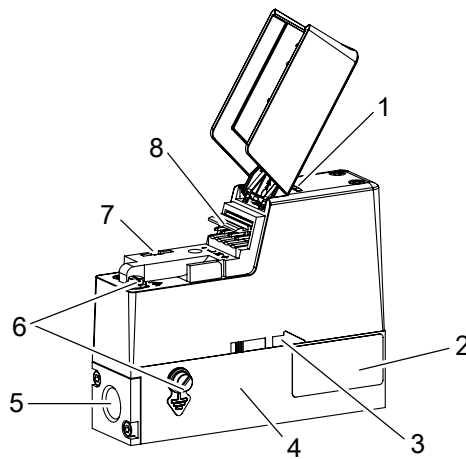

Fig. 3: Example of a variant MFM büS/CANopen

1 Status indicator	2 Type label
3 Flow direction marking	4 Base block
5 Medium connection	6 Functional earth connection
7 Slot for memory card	8 Electrical connection

MFM RS485/Modbus RTU

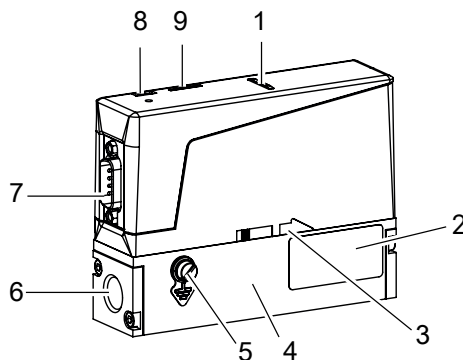

Fig. 4: Example of a variant MFM RS485/Modbus RTU

1 Status indicator	2 Type label
3 Flow direction marking	4 Base block
5 Functional earth connection	6 Medium connection
7 Electrical connection	8 büS interface
9 Slot for memory card	

MFC Analogue

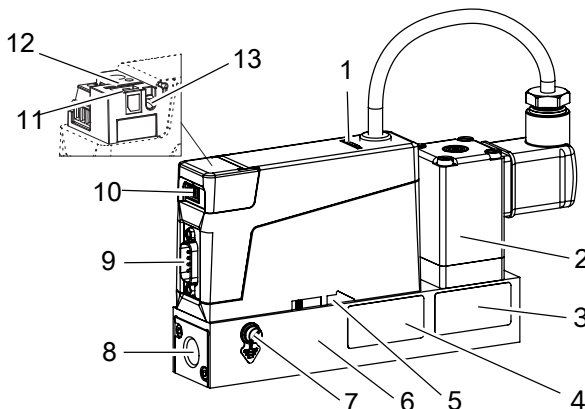

Fig. 5: Example of a variant MFC Analogue

1 Status indicator	2 Proportional valve
3 Type label	4 Calibration label
5 Flow direction marking	6 Base block
7 Functional earth connection	8 Medium connection
9 Electrical connection	10 Not used
11 büS interface	12 Slot for memory card
13 Not used	

MFC Industrial Ethernet

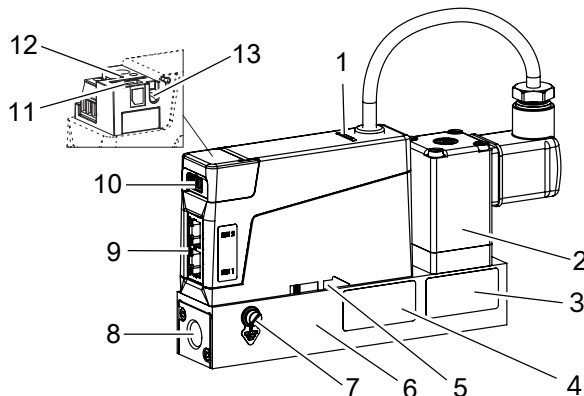

Fig. 6: Example of a variant MFC Industrial Ethernet

1 Status indicator	2 Proportional valve
3 Type label	4 Calibration label
5 Flow direction marking	6 Base block
7 Functional earth connection	8 Medium connection
9 Electrical connection	10 3-pin removable terminal strip
11 bus interface	12 Slot for memory card
13 Communication indicator	

MFC bus/CANopen

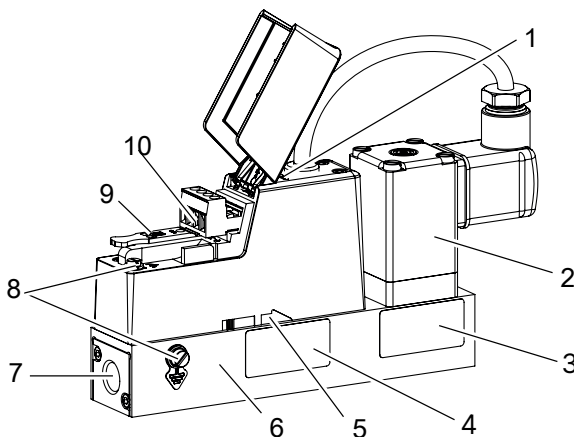

Fig. 7: Example of a variant MFC bus/CANopen

1 Status indicator	2 Proportional valve
3 Type label	4 Calibration label
5 Flow direction marking	6 Base block
7 Medium connection	8 Functional earth connection
9 Slot for memory card	10 Electrical connection

MFC RS485/Modbus RTU

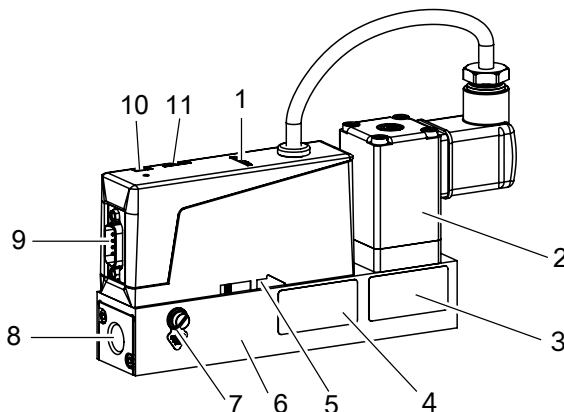

Fig. 8: Example of a variant MFC RS485/Modbus RTU

1 Status indicator	2 Proportional valve
3 Type label	4 Calibration label
5 Flow direction marking	6 Base block
7 Functional earth connection	8 Medium connection
9 Electrical connection	10 bÜS interface
11 Slot for memory card	

3.2 Product identification

3.2.1 Type label

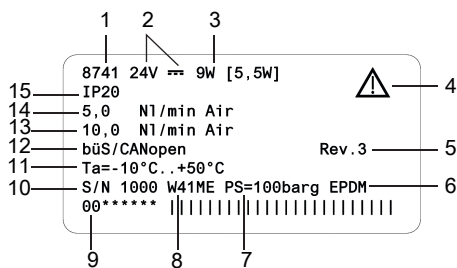

Fig. 9: Example of type label Type 8741

1 Type	2 Operating voltage
3 Power consumption	4 Note: Observe the operating instructions
5 Bürkert internal version	6 Sealing material
7 Burst pressure	8 Manufacture code
9 Article number	10 Serial number
11 Ambient temperature	12 Protocol
13 Nominal mass flow rate (Q nominal), unit and operating gas 2	14 Nominal mass flow rate (Q nominal), unit and operating gas 1
15 Degree of protection	

3.2.2 Calibration label

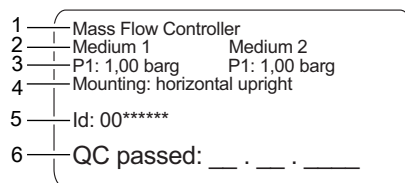

Fig. 10: Example of calibration label

1 Variant	2 Calibration medium
3 Calibration pressure	4 Installation position
5 Article number	6 Calibration date

3.2.3 Conformity marking

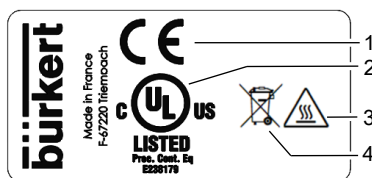

Fig. 11: Conformity label

1 CE marking	2 Certification marking for USA and/or Canada
3 Warning: hot surface	4 Indication for disposal

3.2.4 Symbols and markings on device



Earth terminal



Direct current

Industrial Ethernet variant

DC-B0-58-FF-FF- Example of marking of the MAC address
FF

ETH1, ETH2 Ethernet connections

3.3 Display elements

3.3.1 Status indicator

The status indicator changes its colour based on the NAMUR recommendation NE 107. Refer to [NAMUR mode \[► 18\]](#).

Type 8741

Product description

The colour of the status indicator indicates:

- Whether device diagnostics are active or not. Diagnostics are active on the device and cannot be deactivated.
- If diagnostics are active, then the status indicator shows whether diagnostics events have been generated or not. If several diagnostics events have been generated, then the status indicator shows the diagnostics event with the highest priority.

If the status indicator flashes, then the device is selected in a man-machine interface such as the Bürkert Communicator software.

- ▶ To solve a problem indicated by the status indicator, refer to [Troubleshooting \[▶ 62\]](#)

3.3.2 NAMUR mode

The status indicator shows the status of the device and its peripherals, based on NAMUR recommendation 107 (NE 107).

If various alerts are present, the status indicator always shines in the colour of the highest prioritised alert (red = outage = highest priority).

Colour	Colour code	Status signal	Description
Red	5	Failure	Due to a malfunction in the device or its periphery, normal operation is not possible.
Orange	4	Check function	Work is being carried out on the device, which means that normal operation is temporarily not possible.
Yellow	3	Out of specification	The environmental or process conditions for the device are outside the specified range. Internal device diagnosis indicate problems in the device or process characteristics.
blue	2	Maintenance required	The device is in normal operation, although a function is briefly restricted. ▶ Service device
Green	1	Diagnosis active	Device is running faultlessly, diagnosis are active.
White	0	Diagnosis passive	Device is switched on, diagnosis are inactive.

Tab. 1: Status indicator according to NE 107

3.3.3 Network status indicator

Industrial Ethernet variant

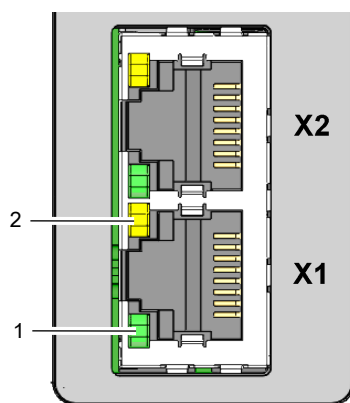

Fig. 12: Location and description of the LED's of an RJ45 socket

1 Link/Act LED (green)	2 Link LED (yellow)
------------------------	---------------------

3.3.4 Communication indicator

Industrial Ethernet variant

This LED shows the status of the communication between the device and the PLC (Programmable Logical Controller).

LED indicator	Description	Meaning
Green	RUN	Connection to the PLC is active.
Red	ERROR	Connection to the PLC is inactive.

Tab. 2: Description of the communication indicator

3.4 Functionality

3.4.1 Service-büS interface

Analogue variant | Industrial Ethernet variant | RS485/Modbus RTU variant

The Service-büS interface is used for short-term servicing of the device with the Bürkert Communicator.

The Bürkert Communicator runs under Windows. Refer to [Connect to the Bürkert Communicator \[▶ 47\]](#)

The USB-büS-Interface set, available as an accessory, is necessary. Refer to [Spare parts and accessories \[▶ 70\]](#)

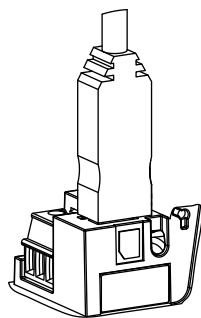

Fig. 13: büS stick, inserted in the related connector of the device

3.4.2 Control valve

MFC with proportional valve

The control valve is a direct-acting and normally-closed proportional valve.

The control valve provides the sealing function when the following conditions are met:

- The device is used within the specified pressure range.
- The device is equipped with a valve seat seal that is made of a soft material such as FKM, FFKM or EPDM.



If the valve seat seal is made of a hard material such as PCTFE, then the control valve may not be tight.

Valves with a seat size of 0.05 mm or 0.1 mm have a seat seal made of a hard material.

Unstable measured values may occur. Refer to [Unstable measured value \[► 66\]](#)

3.4.3 Memory card



If the memory card is defective or has been lost, contact the Bürkert sales office to purchase a new one.

The device can be delivered with a memory card that is inserted in the device. When the device is energised, there are two possibilities:

- If the inserted memory card contains device-specific data, the device automatically adopts this data. At the time of delivery, the memory card is preloaded with device-specific information. To view the stored data, refer to the file Device Description File.
- If the inserted memory card is empty, the device saves its own data onto the card. A new memory card is empty.

To download the file Device Description File:

- ▶ Access the page [Type 8741](#)
- ▶ Scroll down to **Downloads** > **Software**

The data stored on the memory card can be transferred to another device with the same article number. For example, data from a defective device can be transferred to a replacement device.

büS / CANopen variant

The büS/CANopen variant supports the config-client if no memory card is used.

- ▶ Activate this functionality in the Bürkert communicator under **General settings** > **Parameter** > **Act as a configuration client** > **Yes**.

For detailed information, refer to the "Software manual | Central configuration management".

- ▶ Access the page [Type 8741](#)
- ▶ Scroll down to **Downloads** > **User Manuals**

4 Technical data

4.1 Standards and directives

This product complies with the legal requirements applicable at the time of placing on the market and has been developed and tested in accordance with the relevant European directives/regulations and harmonized standards. The conformity is documented and, if necessary, supported by evidence. The EU Declaration of Conformity can be found behind the respective type on the home page country.burkert.com

4.2 Operating conditions

MFM

Ambient temperature	-10...+50 °C
Storage temperature	-10...+70 °C
Degree of protection (EN 60529 / IEC 60529)	IP20 ¹⁾
Medium temperature	<ul style="list-style-type: none"> -10...+70 °C -10...+60 °C for oxygen
Medium	Refer to the type label Clean and dry. Quality classes according to DIN ISO 8573-1.
Operating pressure	max. 25 bar (g)
Relative air humidity	< 95 %, non-condensing

MFC with proportional valve

Ambient temperature	-10...+50 °C
Storage temperature	-10...+70 °C
Degree of protection (EN 60529 / IEC 60529)	IP20 ¹⁾
Medium temperature	<ul style="list-style-type: none"> -10...+70 °C -10...+60 °C for oxygen
Medium	Refer to the type label Clean and dry. Quality classes according to DIN ISO 8573-1.
Operating pressure	Max. 25 bar (g) (depending on the nominal diameter of the valve)
Relative air humidity	< 95 %, non-condensing

¹⁾ When cables or plugs and sockets are connected correctly, verified by Bürkert, not evaluated by UL.

4.3 Medium data

Calibration medium	Operating fluid or air
Mass flow rate range (reference to N ₂ (I _N /min))	<ul style="list-style-type: none"> • 0.025...160 I_N/min (if measurement range 1:50) • 0.01...160 I_N/min (if measurement range 1:20)
Measurement accuracy, after warm-up time	±0.8% ²⁾ of the measured value ±0.3% ²⁾ of the full scale
Turndown ratio	1:20 (Q _{nom} < 0,025 I _N /min) 1:50 (Q _{nom} ≥ 0,025 I _N /min) others on request
Repeatability	±0.1% of the full scale

Quality of the medium

NOTICE!

The medium must obey the quality criteria to obey the following requirements:

- ▶ the necessary measurement accuracy of the device
- ▶ to meet the safety requirements
- ▶ to meet the closed-loop control accuracy of an MFC

✓ For further information on the quality criteria, refer to ISO 8573-1.

Criteria	Quality class	Value
Maximum particle size	2	1 µm
Maximum particle density	2	1 mg/m ³
Maximum dew point under pressure	4	3 °C
Maximum oil concentration	1	0.01 mg/m ³

Tab. 3: Quality criteria of the medium, ISO 8573-1, Compressed Air - Part 1: Contaminants and purity classes

²⁾ If the operation medium deviates from the calibration medium, the actual measurement accuracy might vary from the value specified in the data sheet. If the medium is natural gas, the measurement accuracy depends on the composition of the natural gas, which can vary depending on the origin and season.

4.3.1 Pressure loss

MFM

A mass flow meter has a pressure loss that depends on the following parameters:

- the flow rate value
 - the size of the device connections
 - the type of the device connections
 - the size of the device base-block
 - the type of operating medium
- Determine the pressure-loss value depending on whether the medium is air or a gas other than air.

4.3.1.1 Medium is air or nitrogen

If the medium is air or nitrogen, read the pressure-loss value directly from the diagram in following figures.

The diagram shows an example of the pressure loss characteristics when air flows through. To determine the pressure loss of other gases, the corresponding air equivalent must first be calculated and the base block used for the other gas taken into account.

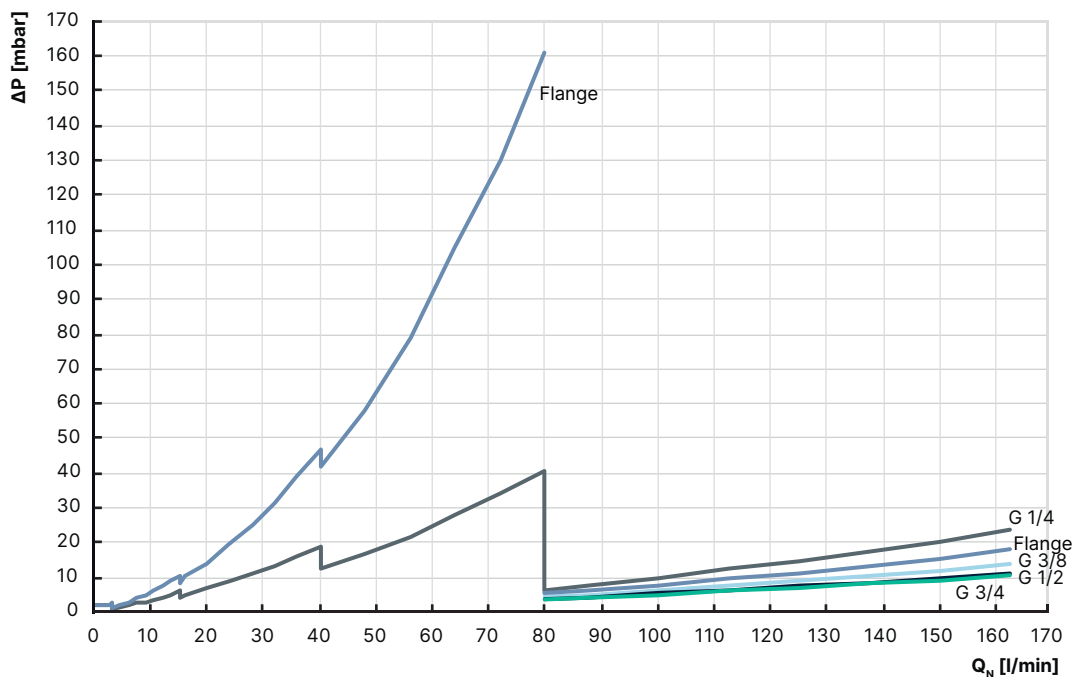

Fig. 14: Pressure loss diagram MFM

4.3.1.2 Medium is not air or nitrogen

If the medium is not air or nitrogen, determine the pressure loss as follows:

- Read the air pressure-loss ΔP_{Air} from the diagram (approach $Q_{\text{Gas}} = Q_{\text{Air}}$).
- Calculate the pressure loss ΔP_{Gas} with the following formula.

$$\Delta P_{Gas} = \Delta P_{Air} \cdot \sqrt{\frac{\rho_{N,Gas}}{\rho_{N,Air}}}$$

Fig. 15: Formula to calculate the pressure loss in an MFM

ΔP_{Gas}	Pressure loss of the medium
ΔP_{Air}	Pressure loss of air
$\rho_{N,Gas}$	Density of the medium at the standard conditions according to DIN 1343 $P_N = 1013.25 \text{ mbar}, T_N = 273.15 \text{ K}$
$\rho_{N,Air}$	Density of air at the standard conditions according to DIN 1343 $P_N = 1013.25 \text{ mbar}, T_N = 273.15 \text{ K}$

Example for argon gas that flows through an MFM with 1/4" threaded connections:

- ▶ If the flow rate is 55 l_N/min then the air pressure-loss P_{air} as given in previous figure is 20 mbar.
- ▶ The pressure loss for argon gas at a flow rate of 55 l_N/min is 27,6 mbar as given by the following formula.

$$\Delta P_{Argon} = 20 \text{ mbar} \cdot \sqrt{\frac{1,784}{1,294}} = 27,6 \text{ mbar}$$

Fig. 16: Calculation of the pressure loss for argon gas

4.4 Electrical data

MFM Analogue

Operating voltage	24 V $\overline{=}$ $\pm 10\%$
Power consumption	< 1 W
Analogue input for the measured value 0/4...20 mA	Maximum input impedance: 200 Ω Resolution: 5 μ A
Analogue input for the measured value 0...5/10 V	Minimum input impedance: 20 k Ω Resolution: 2,5 mV
Analogue output for the measured value 0/4...20 mA	Maximum loop impedance: 400 Ω at an operating voltage of 24 V $\overline{=}$ Resolution: 20 μ A
Analogue output for the measured value 0...5/10 V	Maximum current: 20 mA Resolution: 10 mV
Digital input	<ul style="list-style-type: none"> • 0...0.2 V to activate level 1 • 1...4 V or open to activate level 2 • 5...28 V to activate level 3
Relay output type	Normally closed contact (break contact), free of potential
Maximum ratings	1 A, 30 V, 30 VA
Electrical connections	<ul style="list-style-type: none"> • 6-pin terminal strip, pitch 5.0 mm • D-sub DE-9 plug • service bÜS interface
Minimum temperature rating of the cable to be connected to the field wiring terminals:	75 °C

MFM Industrial Ethernet

Operating voltage	24 V $\overline{=}$ $\pm 10\%$
Power consumption	< 1 W
Communication interface	Industrial Ethernet: PROFINET, EtherNet/IP, EtherCAT, Modbus TCP
Electrical connections	<ul style="list-style-type: none"> • 3-pin terminal strip, pitch 3.5 mm • 2 RJ45 sockets • service bÜS interface
Minimum temperature rating of the cable to be connected to the field wiring terminals:	75 °C

MFM büS/CANopen

Operating voltage	24 V \pm 10 %
Power consumption	< 1 W
Communication interface	büS and CANopen. The communication type can be selected with the Bürkert Communicator software.
Electrical connections	4-pin terminals, 5.08 mm grid
Minimum temperature rating of the cable to be connected to the field wiring terminals:	75 °C

MFM RS485/Modbus RTU

Operating voltage	24 V \pm 10 %
Power consumption	< 1 W
Communication interface	Modbus RTU (List 0 or 1). The communication parameters can be chosen with the Bürkert communicator software.
Electrical connections	<ul style="list-style-type: none">• D-sub DE-9 plug• service büS interface
Minimum temperature rating of the cable to be connected to the field wiring terminals:	75 °C

MFC Analogue

Operating voltage	24 V $\overline{=}$ $\pm 10\%$ residual ripple < 2 %
Power consumption	Refer to type label
Analogue input for the measured value 0/4...20 mA	Maximum input impedance: 200 Ω Resolution: 5 μ A
Analogue input for the measured value 0...5/10 V	Minimum input impedance: 20 k Ω Resolution: 2,5 mV
Analogue output for the measured value 0/4...20 mA	Maximum loop impedance: 400 Ω at an operating voltage of 24 V $\overline{=}$ Resolution: 20 μ A
Analogue output for the measured value 0...5/10 V	Maximum current: 20 mA Resolution: 10 mV
Digital input	<ul style="list-style-type: none"> • 0...0.2 V to activate level 1 • 1...4 V or open to activate level 2 • 5...28 V to activate level 3
Relay output type	Normally closed contact (break contact), free of potential
Maximum ratings	1 A, 30 V, 30 VA
Electrical connections	<ul style="list-style-type: none"> • 6-pin terminal strip, pitch 5.0 mm • D-sub DE-9 plug • service bÜS interface
Minimum temperature rating of the cable to be connected to the field wiring terminals:	75 °C

MFC Industrial Ethernet

Operating voltage	24 V $\overline{=}$ $\pm 10\%$ residual ripple < 2 %
Power consumption	Refer to type label
Communication interface	Industrial Ethernet: PROFINET, EtherNet/IP, EtherCAT, Modbus TCP
Electrical connections	<ul style="list-style-type: none"> • 3-pin terminal strip, pitch 3.5 mm • 2 RJ45 sockets • service bÜS interface
Minimum temperature rating of the cable to be connected to the field wiring terminals:	75 °C

MFC büS/CANopen

Operating voltage	24 V \pm 10 % residual ripple < 2 %
Power consumption	Refer to type label
Communication interface	büS and CANopen. The communication type can be selected with the Bürkert Communicator software.
Electrical connections	4-pin terminals, 5.08 mm grid
Minimum temperature rating of the cable to be connected to the field wiring terminals:	75 °C

MFC RS485/Modbus RTU

Operating voltage	24 V \pm 10 % residual ripple < 2 %
Power consumption	Refer to type label
Communication interface	Modbus RTU (List 0 or 1). The communication parameters can be chosen with the Bürkert communicator software.
Electrical connections	<ul style="list-style-type: none"> • D-sub DE-9 plug • service büS interface
Minimum temperature rating of the cable to be connected to the field wiring terminals:	75 °C

4.5 Communication

4.5.1 Industrial Ethernet: EtherCAT



Ethernet interface X1, X2	X1: EtherCAT IN X2: EtherCAT OUT
Acyclic communication (CoE)	SDO
Type	Complex Slave
FMMUs	8
Sync managers	4
Transmission speed	100 Mbit/s
Data transport layer	Ethernet II, IEEE 802.3

EtherCAT® is a registered trademark and patented technology, licensed by Beckhoff Automation GmbH, Germany.

4.5.2 Industrial Ethernet: EtherNet/IP

Pre-defined standard objects	Identity Object (0x01) Message Router Object (0x02) Assembly Object (0x04) Connection Manager (0x06) DLR Object (0x47) QoS Object (0x48) TCP/IP Interface Object (0xF5) Ethernet Link Object (0xF6)
DHCP	supported
BOOTP	supported
Transmission speed	10 and 100 Mbit/s
Duplex modes	Half duplex, full duplex, auto-negotiation
MDI modes	MDI, MDI-X, Auto-MDI-X
Data transport layer	Ethernet II, IEEE 802.3
Address Conflict Detection (ACD)	supported
DLR (ring topology)	supported
CIP reset service	Identity Object Reset Service Type 0 and Type 1

4.5.3 Industrial Ethernet: Modbus TCP

Modbus function codes	1, 2, 3, 4, 16
Transmission speed	10 and 100 Mbit/s
Data transport layer	Ethernet II, IEEE 802.3

4.5.4 Industrial Ethernet: PROFINET IO

Topology recognition	LLDP, SNMP V1, MIB2, Physical Device
Minimum cycle time	2 ms
IRT	not supported
MRP media redundancy	MRP client is supported
Other supported functions	DCP, VLAN Priority Tagging, Shared Device
Transmission speed	100 Mbit/s
Data transport layer	Ethernet II, IEEE 802.3
PROFINET IO specification	V2.42
Application Relations (AR)	The device can simultaneously process up to 2 IO ARs, 1 Supervisor AR, and 1 Supervisor DA AR.

4.6 Mechanical data

Dimensions	Refer to data sheet Type 8741
Base block	Aluminium or stainless steel 1.4305
Housing	Polycarbonate (PC)
Seal	Refer to the type label
Parts in contact with the medium	1.4310, 1.4113, 1.4305

5 Medium connection



Risk of injury or material damage when working on the device or system.

- ▶ Read and observe the chapter **Safety** [▶ 8] before working on the device or system.

5.1 Possible medium connections

- G-internal-threaded connections according to DIN ISO228/1
- NPT-internal-threaded connections according to ASME/ ANSI B 1.20.1
- Flange connection
- Connections with external-threaded vacuum fittings
- Connections with external-threaded compression fittings
- Tri-Clamp

5.2 Installation procedure



WARNING!

Risk of injury that is due to leakage.

At a low mass flow rate and a high pressure, make sure that the installation is tight. The tightness prevents incorrect measurements or leakage of the medium.

To make sure that the installation is tight, observe the following instructions:

- ▶ Use compression fittings. Mount the compression fittings in a way that they are not subject to any stresses.
- ▶ Use pipes with diameter that is adapted to the medium connection of the device, and a smooth surface.

NOTICE!

Malfunction that is due to contamination.

If a contaminated medium is used, then install a filter upstream of the device. The filter mesh-size must be smaller than 25 µm. The filter ensures problem-free functioning of the device.

5.2.1 G1/8"-internal-threaded connections

- ▶ Remove the protective cap that closes the threaded connection.
- ▶ Do the medium connection on one side of the device.
- ▶ Obey the instructions that are given by the manufacturer of the fitting used.
- ▶ Obey the torques that are given by the manufacturer of the fitting used.
- ▶ Do the medium connection on the other side of the device in the same way.

5.2.2 NPT1/8"-internal-threaded connections

- ▶ Do the medium connection on one side of the device.

- ▶ Obey the instructions that are given by the manufacturer of the fitting used.
- ▶ Obey the torques that are given by the manufacturer of the fitting used.
- ▶ Do the medium connection on the other side of the device in the same way.

5.2.3 Flange connections

A variant with flange connections is mounted on a process connection plate by the manufacturer.

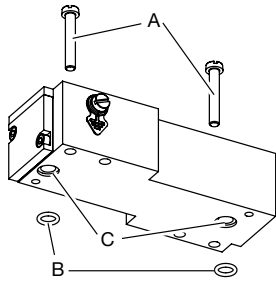

- ▶ Use the M4 screws [A] and O-ring sealings [B] delivered with the device.
- ▶ Place the O-ring sealings in the cavity [C] of the base block.
- ▶ Tighten the screws to a torque of 2,7...2,9 N·m (1,99...2,14 lbf·ft).

Fig. 17: Flange connection with screws and O-ring sealings

5.2.4 Connections with external-threaded vacuum fittings

- ▶ Remove the protective cap that closes the connection.
- ▶ Do the medium connection on one side of the device.
- ▶ Obey the instructions that are given by the manufacturer of the fitting used.
- ▶ **CAUTION! To avoid damage on the sealing of the medium connection, please make sure to lock the hexagonal part in place with a second wrench.**
Obey the torques that are given by the manufacturer of the fitting used.
- ▶ Do the medium connection on the other side of the device in the same way.

5.2.5 Connections with external-threaded compression fittings

- ▶ Do the medium connection on one side of the device.
- ▶ Obey the instructions that are given by the manufacturer of the fitting used.
- ▶ **CAUTION! To avoid damage on the sealing of the medium connection, please make sure to lock the hexagonal part in place with a second wrench.**
Obey the torques that are given by the manufacturer of the fitting used.
- ▶ Do the medium connection on the other side of the device in the same way.

5.2.6 Tri-clamp connections

- ▶ Remove the protective cap that closes the threaded connection.
- ▶ Do the medium connection on one side of the device.
- ▶ Obey the instructions that are given by the manufacturer of the fitting used.
- ▶ Do the medium connection on the other side of the device in the same way.

6 Electrical connection



Risk of injury or material damage when working on the device or system.

- ▶ Read and observe the chapter [Safety \[▶ 8\]](#) before working on the device or system.

6.1 Additional documentation

Further documentation concerning the product:

- ▶ Access the page [Type 8741](#)
- ▶ Scroll down to **Downloads**
- ▶ Or enter the article number from the type label in the search bar.

6.2 Wire the variant büS /CANopen

NOTICE!

UL approved versions must be supplied in one of the following ways:

- ▶ "Limited Energy Circuit" (LEC), according to UL / IEC61010-1
- ▶ "Limited Power Source" (LPS), according to UL / IEC60950
- ▶ SELV / PELV with UL-approved overcurrent protection, designed according to UL / IEC61010-1, Table 18 (e.g. Block PM-0124-020-0)
- ▶ NEC Class 2 power supply unit

6.2.1 With büS extension cables from Bürkert



Requirements for the correct operation of the device: refer to the Cabling Guide | büS/EDIP.

- ▶ Access the page [Type 8741](#)
- ▶ Scroll down to **Downloads** > **User Manuals**

To wire the device, use büS extension cables from Bürkert.

- ▶ Screw the mating female connector onto the 5-pin male connector. Apply the tightening torque specified by the manufacturer of the mating female connector.
- ▶ Do the functional earthing of the device. Refer to [Connect the functional earth \[▶ 45\]](#).

6.2.2 With büS cables from Bürkert



Requirements for the correct operation of the device: refer to the Cabling Guide | büS/EDIP.

- ▶ Access the page [Type 8741](#)
- ▶ Scroll down to **Downloads** > **User Manuals**

To wire the device, büS cables and mating female connectors are available from Bürkert.

If a bus cable from Bürkert is used, then observe the signals of the conductors.

Colour of the bus cable conductor	Signal
red	24 V \equiv
black	GND
white	CAN_H
blue	CAN_L

Tab. 4: Signals of the bus cable conductors

NOTICE!

If an own mating female connector is used, then observe the following requirements for the correct operation of the device.

- ▶ Use a mating female connector with shield connection.
- ▶ Make sure that the bus cable passes through the mating female connector. The bus cable that is available from Bürkert has an external diameter of 8.2 mm.

5-pin M12 male connector (A coding)	Pin	Assignment
	1	Shield
	2	24 V \equiv
	3	GND
	4	CAN_H
	5	CAN_L
	6	Coding lug

M12 thread is internally connected to FE

Tab. 5: Pin assignment, 5-pin M12 male connector (A coding) of the device

- ▶ Wire the mating female connector. Observe the instructions that are given by the manufacturer of the mating female connector.
- ▶ Insert each conductor into the appropriate pin.
- ▶ Take a strand of the cable shielding and insert the strand into pin 1.
- ▶ Screw the mating female connector to the 5-pin male connector, to the torque given by the manufacturer of the mating female connector.
- ▶ Do the functional earthing of the device. Refer to [Connect the functional earth \[▶ 45\]](#)

6.2.3 With CANopen cables



Requirements for the correct operation of the device.

- ▶ Use shielded CANopen cables. The cable shielding can be either a braid shielding or a foil shielding.

To wire the device, mating female connectors are available from Bürkert.

NOTICE!

Requirements for the correct operation of the device.

- ▶ Use a mating female connector with shield connection.
- ▶ Observe the specifications for the cable and conductors, that are given by the manufacturer of the mating female connector.

5-pin M12 male connector (A coding)	Pin	Assignment
	1	Shield
	2	24 V \equiv
	3	GND
	4	CAN_H
	5	CAN_L
	6	Coding lug

M12 thread is internally connected to FE

Tab. 6: Pin assignment, 5-pin M12 male connector (A coding) of the device

- ▶ Wire the mating female connector. Observe the instructions that are given by the manufacturer of the mating female connector.
- ▶ Insert each conductor into the appropriate pin.
- ▶ Take a strand of the cable shielding and insert the strand into pin 1.
- ▶ Screw the mating female connector to the 5-pin male connector, to the torque given by the manufacturer of the mating female connector.
- ▶ Do the functional earthing of the device. Refer to [Connect the functional earth \[▶ 45\]](#)

6.3 Wire the variant Analogue with D-sub DE-9 male connector

NOTICE!

Requirements for the correct operation of the device.

- ▶ Use a power supply unit with sufficient power.
- ▶ Use shielded cables only.
- ▶ Connect each cable end to the functional earth.
- ▶ For an MFC pay attention to the maximum permissible residual ripple on the operating voltage (residual ripple < 2 %).

NOTICE!

UL approved versions must be supplied in one of the following ways:

- ▶ "Limited Energy Circuit" (LEC), according to UL / IEC61010-1
- ▶ "Limited Power Source" (LPS), according to UL / IEC60950
- ▶ SELV / PELV with UL-approved overcurrent protection, designed according to UL / IEC61010-1, Table 18 (e.g. Block PM-0124-020-0)
- ▶ NEC Class 2 power supply unit



The cable shield is connected by the housing of the D-sub DE-9 male connector.

MFM

D-sub DE-9 male connector	Pin	Assignment
	1	Digital input
	2	GND for the digital input and the power supply
	3	+24 V $\overline{=}$
	4	Relay: normally closed contact (Break contact)
	5	Relay: reference contact
	6	Not used
	7	Not used
	8	Analogue output for the measured value
	9	GND for the analogue output
Housing		FE

Tab. 7: Pin assignment of the D-sub DE-9 male of the device

- ▶ Wire a D-sub DE-9 female connector according to the pin assignment.
- ▶ Connect the D-sub DE-9 female connector to the D-sub DE-9 male connector.
- ▶ Tighten the screws to a torque of 0,5...0,6 N·m (0,37...0,44 lbf·ft).
- ▶ Connect the functional earthing of the device. Refer to [Connect the functional earth \[▶ 45\]](#)

MFC

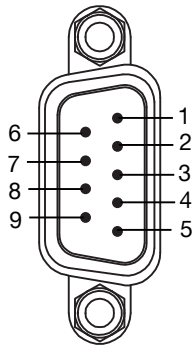

D-sub DE-9 male connector	Pin	Assignment
	1	Digital input
	2	GND for the digital input and the power supply
	3	+24 V $\overline{=}$
	4	Relay: normally closed contact (Break contact)
	5	Relay: reference contact
	6	Set-point input
	7	GND for the set-point input
	8	Analogue output for the measured value
	9	GND for the analogue output
Housing		FE

Tab. 8: Pin assignment of the D-sub DE-9 male of the device

- ▶ Wire a D-sub DE-9 female connector according to the pin assignment.
- ▶ Connect the D-sub DE-9 female connector to the D-sub DE-9 male connector.
- ▶ Tighten the screws to a torque of 0,5...0,6 N·m (0,37...0,44 lbf·ft).
- ▶ Connect the functional earthing of the device. Refer to [Connect the functional earth \[▶ 45\]](#)

6.3.1 Digital input

The D-sub DE-9 male connector has a digital input. A digital input is used to remotely trigger a function.

Available functions on MFM

- Reset the totalizer for the active gas.
- Select which gas is active among 3 gases.

Default assignment

No assignment

Available functions on MFC

- Start the function autotune.
- Trigger the remote control of the actuator or trigger the control of the actuator by the device.
- Reset the totalizer for the active gas.
- Select which gas is active among 3 gases.
- Select the set-point value.

Default assignment

Start autotune

- ▶ To select the function to be remotely triggered over the digital input, use the Bürkert Communicator. Only one of the available functions can be associated to the digital input.

A function has up to 3 possible switching levels which may trigger different actions. The following table gives the actions that are associated to the switching levels, and how each level is activated.

MFM | Digital input 1 inverted

Function	Level 1 "low" ³⁾	Level 2 "open" ⁴⁾	Level 3 "high" ⁵⁾
Reset totalizer	Resets the Totalizer	-	-
Gas selection for 2 gases	Switches to gas 2	Switches to gas 1	Switches to gas 1
Gas selection for 3 gases ⁶⁾	Switches to gas 2	Switches to gas 1	Switches to gas 3

Tab. 9: Actions triggered by the switching levels

MFM | Digital input 1 not inverted

Function	Level 1 "low" ³⁾	Level 2 "open" ⁴⁾	Level 3 "high" ⁵⁾
Reset totalizer	-	-	Resets the Totalizer
Gas selection for 2 gases	Switches to gas 1	Switches to gas 1	Switches to gas 2
Gas selection for 3 gases ⁶⁾	Switches to gas 3	Switches to gas 1	Switches to gas 2

Tab. 10: Actions triggered by the switching levels

3) Digital input is connected to GND
 4) Digital input is not connected (alternatively: 1..4 V $\overline{\text{---}}$)
 5) Digital input is connected to +24 V $\overline{\text{---}}$ (alternatively: 5...28 V $\overline{\text{---}}$)
 6) Not possible to select the 4th gas curve

MFC | Digital input 1 inverted

Function	Level 1 "low" ⁷⁾	Level 2 "open" ⁸⁾	Level 3 "high" ⁹⁾
Start autotune	Starts Autotune	-	-
Set-point value source	Triggers Stored set-point active	-	Triggers Open-loop control mode
Reset totalizer	Resets the Totalizer	-	-
Gas selection for 2 gases	Switches to gas 2	Switches to gas 1	Switches to gas 1
Gas selection for 3 gases ¹⁰⁾	Switches to gas 2	Switches to gas 1	Switches to gas 3
Actuator control	Opens the actuator completely	-	Closes the actuator
Close actuator	Closes the actuator	-	-

Tab. 11: Actions triggered by the switching levels

MFC | Digital input 1 not inverted

Function	Level 1 "low" ⁷⁾	Level 2 "open" ⁸⁾	Level 3 "high" ⁹⁾
Start autotune	-	-	Starts Autotune
Set-point value source	Triggers Open-loop control mode	-	Triggers Stored set-point active
Reset totalizer	-	-	Resets the Totalizer
Gas selection for 2 gases	Switches to gas 1	Switches to gas 1	Switches to gas 2
Gas selection for 3 gases ¹⁰⁾	Switches to gas 3	Switches to gas 1	Switches to gas 2
Actuator control	Closes the actuator	-	Opens the actuator completely
Close actuator	-	Closes the actuator	Closes the actuator

Tab. 12: Actions triggered by the switching levels

6.3.2 Relay output

The D-sub DE-9 male connector has a relay output.

7) Digital input is connected to GND

8) Digital input is not connected (alternatively: 1..4 V $\overline{\text{---}}$)

9) Digital input is connected to +24 V $\overline{\text{---}}$ (alternatively: 5...28 V $\overline{\text{---}}$)

10) Not possible to select the 4th gas curve

MFM

The relay switching can show the following events:

- A warning message has been generated. For example if the supply voltage is too high, then a warning message is generated.
- A failure message has been generated. For example if a sensor failure is detected, then a failure message is generated.

Default assignment

No assignment

MFC

The relay switching can show the following events:

- A warning message has been generated. For example if the supply voltage is too high, then a warning message is generated.
- A failure message has been generated. For example if a sensor failure is detected, then a failure message is generated.
- The set-point value cannot be reached.
- The device is doing an Autotune.
- The **Set-point value source** has changed.

Default assignment

The set-point value cannot be reached

- ▶ To choose the events that are assigned to the relay output, use the Bürkert Communicator. Several events can be associated to the relay output.

6.4 Wire the variant Analogue with a 6-pin terminal strip

NOTICE!

Requirements for the correct operation of the device.

- ▶ Use a power supply unit with sufficient power.
- ▶ Use shielded cables only.
- ▶ Connect each cable end to the functional earth.
- ▶ For an MFC pay attention to the maximum permissible residual ripple on the operating voltage (residual ripple < 2 %).

NOTICE!

UL approved versions must be supplied in one of the following ways:

- ▶ "Limited Energy Circuit" (LEC), according to UL / IEC61010-1
- ▶ "Limited Power Source" (LPS), according to UL / IEC60950
- ▶ SELV / PELV with UL-approved overcurrent protection, designed according to UL / IEC61010-1, Table 18 (e.g. Block PM-0124-020-0)
- ▶ NEC Class 2 power supply unit

6-pin terminal strip	Pin	Assignment
	1	+24 V \equiv
	2	GND
	3	Set-point analogue input +
	4	Set-point analogue input GND
	5	Actual value analogue output +
	6	Actual value analogue output GND

Tab. 13: Pin assignment of the 6-pin terminal strip of the device

- ▶ Connect the conductors.
- ▶ Tighten the screws at a torque between 0,5...0,6 N·m (0,37...0,44 lbf·ft).
- ▶ Earth the device. Refer to [Connect the functional earth \[▶ 45\]](#)

6.5 Wire the variant Industrial Ethernet

NOTICE!

Requirements for the correct operation of the device.

- ▶ Use a power supply unit with sufficient power.
- ▶ Use only Industrial Ethernet shielded cables with a category CAT-5e or higher.
- ▶ Connect each cable end to the functional earth.
- ▶ For an MFC pay attention to the maximum permissible residual ripple on the operating voltage (residual ripple < 2 %).

NOTICE!

UL approved versions must be supplied in one of the following ways:

- ▶ "Limited Energy Circuit" (LEC), according to UL / IEC61010-1
- ▶ "Limited Power Source" (LPS), according to UL / IEC60950
- ▶ SELV / PELV with UL-approved overcurrent protection, designed according to UL / IEC61010-1, Table 18 (e.g. Block PM-0124-020-0)
- ▶ NEC Class 2 power supply unit

Connecting the power supply and the functional earth

3-pin terminal strip	Pin	Assignment
	1	FE (functional earth)
	2	DGND
	3	+24 V \equiv

Tab. 14: Terminal assignment of the 3-pin terminal strip of the device

- ▶ Open the cover of the device.
- ▶ Connect the conductors according to the figure.
- ▶ Earth the device. Refer to [Connect the functional earth \[▶ 45\]](#)
- ▶ Tighten the conductors at a torque between 0.22...0.25 N (0.16...0.18 lbf·ft.)

Connecting the Industrial Ethernet

The cable shield is connected by the housing of the cable plug.

Both RJ45 sockets have the same pin assignment.

RJ45	Pin	Assignment
	1	TX+
	2	TX-
	3	RX+
	4	N. C.
	5	N. C.
	6	RX-
	7	N. C.
	8	N. C.
Housing		FE

Tab. 15: Pin assignment of an RJ45 socket of the device

- ▶ If a protocol other than EtherCAT is used, plug an Ethernet cable in one or both sockets.
- ▶ If the EtherCAT protocol is used, plug the incoming Ethernet cable (coming from the PLC) into the socket marked ETH1 and plug the outgoing Ethernet cable into the socket marked ETH2.

6.6 Change the network parameters

Industrial Ethernet variant



The Industrial Ethernet variants Ethernet/IP and ModbusTCP have the same default IP address 192.168.1.100, Profinet devices have 0.0.0.0 by default.

- ▶ Before commissioning the device, change its network parameters.
- ▶ If several devices must be connected to the same Industrial Ethernet network, then connect one device at a time and change its network parameters.

6.6.1 Over the product web server

NOTICE!

Security risk due to default passwords.

Unauthorised persons can log in to the web server and change the parameters.

- ▶ Change the default passwords.
- ▶ If the web server is not required, disable access using Bürkert Communicator. Refer to [Configuration with Bürkert Communicator \[▶ 47\]](#).

Prerequisites:

- The industrial Ethernet variant is not EtherCAT
- Digital device (PC, tablet,...) with a web browser.
- Possibly, a USB-Ethernet adapter.
- ▶ Connect the device to the digital device with an Ethernet cable. Alternatively, connect the device to the PC with a USB-Ethernet adapter.
- ▶ Energise the digital device and the device.
- ▶ If the device is connected to the digital device over a USB-Ethernet adapter, then configure the IP address of the USB-Ethernet adapter. Else, configure the IP address of the network card of the digital device.
- ▶ Change the IP address to 192.168.1.xxx, where xxx is different from 100.
- ▶ Open the web browser. In the address bar of the web browser, enter 192.168.1.100.
 - ✓ The home page of the web server opens. Some device data are shown.
- ▶ Open a web server session, to configure the network parameters of the device.
- ▶ If you are not automatically invited to log in, select **Login**.
- ▶ **User name**: enter admin
- ▶ **User password**: enter admin
- ▶ Click **Login**.
- ▶ Change the default passwords with customised passwords.
- ▶ Change the network parameters of the device.
- ▶ Select **Industrial communication** > **Configuration**.
- ▶ Change the parameters.
- ▶ To save the changes, select **Apply**.
- ▶ To update the parameters, select **Restart**.
- ✓ The device restarts.
- ✓ The network parameters of the device are changed.

6.6.2 Over the Bürkert Communicator software

- ▶ Connect the device to the Bürkert Communicator software. Refer to [Configuration with Bürkert Communicator \[▶ 47\]](#).
- ▶ Change the network parameters of the device.
- ▶ Select **Industrial communication** > **Parameter**.

- ▶ Change the parameters.
- ▶ To update the parameters, restart the device.
- ✓ The device restarts.
- ✓ The network parameters of the device are changed.

6.7 Wire the variant RS485/Modbus RTU

NOTICE!

Requirements for the correct operation of the device.

- ▶ Use a power supply unit with sufficient power.
- ▶ Use shielded cables only.
- ▶ Connect each cable end to the functional earth.
- ▶ For an MFC pay attention to the maximum permissible residual ripple on the operating voltage (residual ripple < 2 %).

NOTICE!

UL approved versions must be supplied in one of the following ways:

- ▶ "Limited Energy Circuit" (LEC), according to UL / IEC61010-1
- ▶ "Limited Power Source" (LPS), according to UL / IEC60950
- ▶ SELV / PELV with UL-approved overcurrent protection, designed according to UL / IEC61010-1, Table 18 (e.g. Block PM-0124-020-0)
- ▶ NEC Class 2 power supply unit



The cable shield is connected by the housing of the D-sub DE-9 male connector.

D-sub DE-9 male connector	Pin	Assignment
	1	Not used
	2	GND
	3	+24 V \equiv
	4	Not used
	5	Not used
	6	TX+ (RS485-Y) * bridge with Pin 9 for Half-Duplex
	7	TX- (RS485-Z) *bridge with Pin 8 for Half-Duplex
	8	RX- (RS485-B)
	9	RX+ (RS485-A)
Housing		FE

Tab. 16: Pin assignment of the D-sub DE-9 male of the device

- ▶ Wire a D-sub DE-9 female connector according to the pin assignment.
- ▶ Connect the D-sub DE-9 female connector to the D-sub DE-9 male connector.

- ▶ Tighten the screws to a torque of 0,5...0,6 N·m (0,37...0,44 lbf·ft).
- ▶ Connect the functional earthing of the device. Refer to [Connect the functional earth \[▶ 45\]](#)

6.8 Connect the functional earth

WARNING!

Risk of ignition and risk of fire that are due to electrostatic discharge.

An electrostatic discharge of the device can ignite combustible gas vapours.

- ▶ To avoid a build up of electrostatic charge, connect the housing to the functional earth.
- ▶ If the functional earth is not attached, then the requirements of the EMC directive are not met.

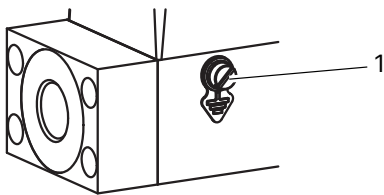

Fig. 18: Location of the M4 screw for the connection of the functional earth

1 M4 screw

- ▶ Use a green-and-yellow cable that is as short as possible. And the cable cross-section must be at least equal to the cross section of the power-supply cable.
- ▶ With a flat screwdriver of size 6.5 mm, loosen the M4 screw.
- ▶ Attach the green-and-yellow cable to the M4 screw with a cable lug.
- ▶ Tighten the M4 screw to a torque of 1,8 N·m...2 N·m (1,33 lbf·ft...1,47 lbf·ft).

7 Commissioning



Risk of injury or material damage when working on the device or system.

- ▶ Read and observe the chapter [Safety \[▶ 8\]](#) before working on the device or system.
-

7.1 Commissioning procedure

- ▶ Pressurise the pipes with medium.
- ▶ Flush the pipes with medium at the calibration pressure.
- ▶ Vent the pipes completely.
- ▶ Check if the memory card is inserted.
- ▶ Energise the device.
- ▶ If the device is an MFC, and the medium is not the calibration medium or the pressure conditions have changed, then run the Autotune function. Refer to [Optimise the closed-loop control parameters \[▶ 55\]](#)
- ✓ The device operates normally.

8 Configuration with Bürkert Communicator

8.1 Setting tools



The MassFlowCommunicator is another PC software that is not compatible with the device. The MassFlowCommunicator software cannot be used to configure or operate the device.

Settings can be made with the Type 8920 Bürkert Communicator. For general information about the Bürkert Communicator, refer to the operating instructions of Type 8920.

- ▶ Access the page [Type 8920](#)
- ▶ Scroll down to **Downloads** > **User Manuals**

8.2 Connect to the Bürkert Communicator

[Analogue variant](#) | [Industrial Ethernet variant](#) | [RS485/Modbus RTU variant](#)

- ▶ Use the USB-büS-Interface set, article number 00772551.
- ▶ Download the latest version of the Type 8920 Bürkert Communicator.
- ▶ Access the page [Type 8920](#)
- ▶ Scroll down to **Downloads** > **Software**
- ▶ Install the Bürkert Communicator on a PC. During installation, the büS stick must not be connected to the PC.
- ▶ Assemble the parts of the USB-büS-Interface set.



Fig. 19: Assembled parts of the USB-büS-Interface set

- ▶ Set the termination-resistance switch of the büS stick to ON.
- ▶ Insert the büS stick into a USB port of the PC.
- ▶ Energise the device. Refer to [Electrical connection](#) [▶ 33]
- ▶ Insert the micro-USB connector into the büS interface of the device. Refer to [Product description](#) [▶ 11]
- ▶ Wait until the driver of the büS stick has been completely installed on the PC.
- ▶ Start the Bürkert Communicator.



- ▶ Click on  in the Bürkert Communicator to establish the communication with the device.

✓ A window opens.

- ▶ Select **Connect via USB (büs Stick)**.
- ▶ Select the port Bürkert USB büS stick, click on **Finish** and wait until the device symbol appears in the list of devices.
- ▶ In the navigation area, click on the symbol related to the device: The device menu appears.

büs / CANopen variant

- ▶ Use the USB-büs-Interface set, article number 00772426.



Fig. 20: USB-büs-Interface set

1 büS stick with termination-resistance switch

- ▶ Download the latest version of the Type 8920 Bürkert Communicator.
- ▶ Access the page [Type 8920](#)
- ▶ Scroll down to **Downloads > Software**
- ▶ Install the Bürkert Communicator on a PC. During installation, the büS stick must not be connected to the PC.

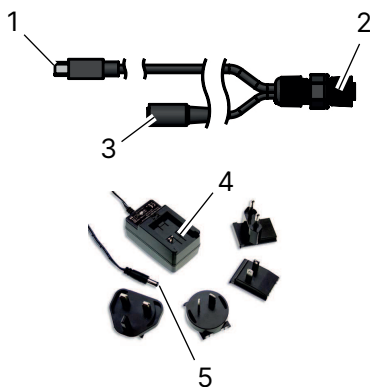



Fig. 21: Electrical connection parts of the USB-büs-Interface set

1 Micro-USB connector	2 5-pin M12 female connector
3 Jack female connector	4 AC/DC adapter
5 Jack male connector	

- ▶ Insert the micro-USB plug into the büS stick.
- ▶ Insert the appropriate power adapter into the AC/DC adapter.

- ▶ Connect the jack male-connector of the AC/DC-adapter cable to the jack female-connector of the M12 female-connector cable.
- ▶ Connect the M12 female connector to the bÜS network.
- ▶ If the device is connected to a bÜS network and is at a bÜS end, then set the bÜS stick switch to "ON". The termination resistance that is integrated in the bÜS stick is then activated.
- ▶ Insert the bÜS stick into a USB port of the PC.
- ▶ Wait until the Windows pilot of the bÜS stick has been completely installed on the PC.
- ▶ Connect the AC/DC adapter to the power supply.
- ▶ Start the Bürkert Communicator.
- ▶ Click on  in the Bürkert Communicator to establish the communication with the device.
 - ✓ A window opens.
- ▶ Select **Connect via USB (bÜS Stick)**.
- ▶ Select the port Bürkert USB bÜS stick, click on **Finish** and wait until the device symbol appears in the list of devices.
- ▶ In the navigation area, click on the symbol related to the device: The device menu appears.

8.3 Setting the Industrial Ethernet address

- ▶ To set the fieldbus address, use the Bürkert Communicator.
- ▶ Or use the man-machine interface of the PLC the device is connected to.
- ▶ If the address is changed and to avoid malfunction of the device, restart the device by turning off and on the power supply.

8.4 Functions

8.4.1 Shut-Off threshold for the valve

A shut-Off threshold ensures the sealing function of the control valve (except valve with PCTFE seat sealing). If the used set-point value is below the shut-off threshold, the control signal for the valve is set to 0% immediately.

8.4.2 Cut-Off threshold for actual flow

A cut-off threshold for the actual flow is calculated from the nominal flow, the measuring span and a calculation factor. Measured values below the calculated cut-off threshold will be displayed as zero actual flow.

8.4.3 Flush mode

Industrial Ethernet variant | RS485/Modbus RTU variant | bÜS / CANopen variant



MFC: If the integrated valve is fully open, the internal device temperature increases. If the internal device temperature increases, the device can be damaged.

- ▶ Do not let the valve fully open for more than 10 minutes.
-

To open the valve completely:

- ▶ Send an acyclic command to the device.
- ▶ Or send a cyclic command with the double nominal flow rate.

8.5 User-defined adjustment

At delivery the device is calibrated by the manufacturer.

With the Bürkert Communicator, it is possible to define an adjustment procedure with up to 32 calibration points.

This procedure is described in device specific **Documents and tools** in the Bürkert Communicator.

- ▶ Connect the device to the Bürkert Communicator. Refer to [Connect to the Bürkert Communicator \[▶ 47\]](#)

8.6 Zero point adjustment

It is possible to perform a zero point adjustment procedure to adapt the sensor characteristic curve to the current conditions (mounting/installation position, medium, operating pressure). The device will be calibrated in installation position in any case. It is possible to use another installation position. Afterwards a zero point adjustment procedure is necessary.

- ▶ Start the communication with the Bürkert Communicator. Refer to [Connect to the Bürkert Communicator \[▶ 47\]](#)
- ▶ Choose the device.
- ▶ Select **Sensor > Diagnostics > Start zero point adjustment**
- ✓ The procedure starts.
- ✓ The device switches the namur status to orange.

8.7 Set-point value sources and operation modes

MFC

Different sources can set the process set-point value. Select one active source at a time.

Change the set-point value source during operation if required. Changing the set-point value source also changes the device operating mode.

When energising the device for the first time, the device enters a short initialisation phase and then switches to the normal operation mode.

- ▶ Connect the device to the Bürkert Communicator. Refer to [Connect to the Bürkert Communicator \[▶ 47\]](#).
- ▶ Select the device.
- ▶ Go to **Controller > Parameter > Set-point value > Set-point value source**.



The **Set-point value source** remains after a restart. It resets only when the selected source is **Manual set-point value** or **Analyze system**.

Set-point value source	Description	Operation mode
Analog set-point value source Only variant Analogue	The analogue input sets the set-point value	Normal operation mode (Closed Loop)
Automatic Only variant Industrial Ethernet	The fieldbus sets the set-point value. If several fieldbus participants simultaneously send values, the device uses the last received value.	Normal operation mode (Closed Loop)
Manual set-point value	For testing or to prevent overwriting by other fieldbus participants.	Normal operation mode (Closed Loop)
Stored setpoint	To use a fixed set-point value (w). After a device restart, the fixed set-point value remains active.	Normal operation mode (Closed Loop)
Open-loop control mode	To directly set the position set-point value (y) to the actuator. The menu Actuator > Parameter > Actuating variable provides the used position set-point value (y). Restarting the device sets the position set-point value (y) to zero.	Open-loop control mode
Analyze system	The device operates in normal operation mode according to a predefined chronological sequence of set-point values. Use the resulting diagram with the graphical process values to analyse the system with the Bürkert Communicator.	Analyse the system

Tab. 17: Set-point value sources and operation modes

8.8 Increase the data transmission speed

büS / CANopen variant

If the data transmission speed is increased, then the device provides more cyclic process-data.

For example, the actual value of the mass flow rate is available once every 100 ms by default. If the data transmission-speed is increased, then the actual value of the mass flow rate is available once every 10 ms.

- ▶ If the data transmission-speed is active simultaneously on several devices in the network, then make sure that the bus load does not exceed 50%.

To increase the data transmission-speed, do the following:

- ▶ Energise the bus network.
- ▶ Connect the device to the Bürkert Communicator software. Refer to [Connect to the Bürkert Communicator \[▶ 47\]](#)
- ▶ Move the PC mouse over the büS-stick symbol in the list of devices. If the bus load is higher than 45%, then do not increase the data transmission-speed.
- ▶ If the bus load is less than or equal to 45%, then the data transmission-speed can be increased. Do the following procedure:

- ▶ Select the device.
- ▶ Select **General settings** > **Parameter** > **PDO Configuration**.
- ▶ To increase the data transmission-speed, change the inhibit time of the PDO to the desired value (min. 10 ms). Confirm the entry with **Apply and Save**.
 - ✓ The data transmission-speed is increased.
- ▶ To go back to the default data transmission-speed, click **Reset to default values**.

8.9 Operation modes

MFC

When energising the device for the first time, the device enters a short initialisation phase and then switches to the normal operation mode. Refer to **Normal operation mode** [▶ 53]

- ▶ To change the operation mode, change the source for the set-point values. Refer to **Select the source that gives the set-point value** [▶ 55]

The operation mode is kept after a device restart, except when the device performs the function **Analyze system**.

8.10 Normal operation mode

MFC

The normal operation mode is active when energising the device for the first time.

MFC with proportional valve



If the valve seat seal is made of a hard material such as PCTFE, then the control valve may not be tight.

Valves with a seat size of 0.05 mm or 0.1 mm have a seat seal made of a hard material.

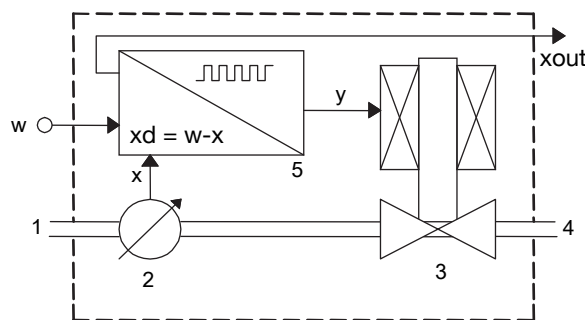

Fig. 22: Function diagram of the MFC with control valve

1 Medium inlet	2 Sensor
3 Control valve	4 Medium outlet
5 Electronics	x measured value of the mass flow rate
y set-point position of the valve	w set-point value of the mass flow rate

The sensor measures the mass flow rate and compares the measured value x with the set-point value w . The device calculates the set-point position value y of the actuator.

- The set-point position value y determines the opening of the control valve. For example, if the set-point position value y is equal to 10%, then the opening of the control valve is 10%.

The transmission means of the set-point value w and the measured value of the flow rate depends on the device.

- ▶ If the operating conditions have changed, then optimise the closed-loop control parameters. Refer to [Optimise the closed-loop control parameters \[▶ 55\]](#)
- ▶ To change the operation mode, change the source for the set-point value. Refer to [Select the source that gives the set-point value \[▶ 55\]](#)

8.10.1 Analogue variant

After applying the operating voltage, the device enters a short initialisation phase and then switches to the normal operation mode. The normal operation mode of a variant Analogue is the **Analog setpoint** operation mode.

- The set-point value w is transmitted over the set-point analogue input according to the ranges in the following table.
- The measured value of the flow rate is transmitted over the analogue output according to the ranges in the following table.

Analogue output range	Minimum value of the input ranges and output ranges	Maximum value of the input ranges and output ranges
4...20 mA	4 mA, $w = 0\%$	20 mA, $w = 100\%$
0...20 mA	0 mA, $w = 0\%$	20 mA, $w = 100\%$
0...5 V \equiv	0 V, $w = 0\%$	5 V, $w = 100\%$
0...10 V \equiv	0 V, $w = 0\%$	10 V, $w = 100\%$

Tab. 18: Analogue-input ranges and analogue-output ranges

8.10.2 Industrial Ethernet variant

After applying the operating voltage, the device enters a short initialisation phase and then switches to the **Automatic** operation mode.

- ▶ To change the control mode, i. e. to change the source for the set-point values. Refer to [Select the source that gives the set-point value \[▶ 55\]](#)
- ▶ To change the control parameters, use the Bürkert Communicator.

8.10.3 bÜS /CANopen variant

If the device detects that the pipe is empty, then the device cannot regulate.

After applying the operating voltage, the device enters a short initialisation phase and switches to the normal operation mode. The normal operation mode of a variant bÜS/CANopen is the **Automatic** operation mode. The set-point value is set via the fieldbus.

8.11 Optimise the closed-loop control parameters

MFC

The closed-loop control parameters of the device can be optimised for the current operating conditions with a function that is called Autotune.

- Run the Autotune function when the device is started for the first time.
- If the operating conditions have changed, then run the Autotune function.

If the device detects that the pipe is empty, then the Autotune function cannot be started.

When the Autotune is running:

- ▶ Do not interrupt the power supply to the device.
- ▶ Keep the supply pressure constant.



WARNING!

Risk of injury from flowing medium.

While the Autotune function is running, the mass flow rate value can be higher than the nominal flow rate value.

- ▶ Before running the Autotune function, make sure that no danger can occur if the mass flow rate value increases.
- ▶ Trigger the Autotune function with one of the following means:
 - ▶ over the fieldbus (variant büS/CANopen),
 - ▶ over the fieldbus (variant Industrial Ethernet)
 - ▶ over the fieldbus (variant RS485 / Modbus RTU)
 - ▶ over the digital input (variant Analogue),
 - ▶ with the Bürkert Communicator. Refer to [Connect to the Bürkert Communicator \[▶ 47\]](#)
- ✓ The Autotune runs and the status indicator is orange.
- ✓ The device temporarily stops regulating the flow rate in the pipe.
- ✓ When the function is completed, the device returns to its previous operating mode.
- ✓ If the function is completed successfully, then the optimised closed-loop control parameters are transferred to the hard memory of the device.

8.12 Select the source that gives the set-point value

MFC

The process set-point value can be set by different sources. It is possible to select which source is active at a time. The source for the set-point value can be changed during operation.

If the source for the set-point value is changed, then the operation mode of the device is changed.

To change the source for the set-point value, change the setting of the parameter **Set-point value source** with the Bürkert Communicator. Refer to [Connect to the Bürkert Communicator \[▶ 47\]](#)



The setting of the parameter **Set-point value source** is kept after a restart, except when the device performs the function **Analyze system** or the set-point value source was set to manual set-point.

büS / CANopen variant | Industrial Ethernet variant

It is possible to alternatively change the related object. Refer to the file Device Description File.

- ▶ Access the page [Type 8741](#)
- ▶ Scroll down to **Downloads** > **Software**

Possible choices for the parameter **Set-point value source**

Variant büS/CANopen: Automatic	The set-point value is set via the fieldbus.
Variant RS485/Modbus RTU: Automatic	The set-point value is set via the fieldbus.
Variant Analogue: Analog set-point value source	The setpoint value is set via the analogue input.
Variant Industrial Ethernet: Automatic	The set-point value is set via the fieldbus. If different fieldbus participants simultaneously specify a set-point value for the device, it is always the last set value that is used.
Manual set-point value	To manually give in a set-point value for testing purposes or to make sure that the set-point value is not overwritten by other fieldbus participants.
Stored setpoint	To use a fixed set-point value (w). If the device is restarted, then the fixed set-point value remains active. Refer to Normal operation mode [▶ 53]
Open-loop control mode	To directly set the set-point position (y) to the actuator. The value that is given in the menu Actuator > Parameter > Actuating variable is the setpoint position (y) that is used. A restart of the device sets the set-point position (y) to zero. Refer to Normal operation mode [▶ 53]
Analyze system	The device operates in the normal operation mode, but according to a predefined chronological sequence with set-point values. Use the resulting diagram in combination with the graphical representation of process values to analyse the system with the Bürkert Communicator.

8.13 Set-point values without communication

Industrial Ethernet variant | büS / CANopen variant | RS485/Modbus RTU variant

The function makes it possible to specify the set-point values of the device even if the communication with the external set-point value provider (for example a PLC) is broken. If the function is used, then the set-point is kept constant.



By using the function, the medium can continue to flow even if the communication is broken.

- ▶ Make sure the process is safe when the function is used.
- ▶ To use the function, refer to the file Device Description File.
- ▶ Access the page [Type 8741](#)

- ▶ Scroll down to **Downloads** > **Software**
- ▶ The configuration is available under **Controller** > **Parameter** > **Setpoint** > **Advanced settings** > **Connection abort behaviour**

8.14 Changing between bÜS and CANopen mode

bÜS / CANopen variant

To select the different digital communication modes (bÜS or CANopen), use the software Bürkert communicator.

- ▶ Connect the device to the Bürkert Communicator software. Refer to [Connect to the Bürkert Communicator \[▶ 47\]](#)
- ▶ Select the device.
- ▶ Select **General settings** > **Parameter** > **bÜS** > **Advanced** > **Bus mode**
- ▶ Select the operating mode of the digital communication.
- ▶ Restart the device.
- ✓ The operating mode of the fieldbus is changed.
- ✓ If the operating mode of the fieldbus is bÜS, the **CANopen status** is set to **Operational** and the PDO's are sent to bÜS.
- ✓ If the operating mode of the fieldbus is CANopen, the **CANopen status** is set to **Pre-Op** until the CANopen network master switches the device to **Operational**.

9 Maintenance

If the device is operated according to the Operating instructions, then the device is maintenance-free.



Risk of injury or material damage when working on the device or system.

- ▶ Read and observe the chapter **Safety** [▶ 8] before working on the device or system.

9.1 Service tasks and intervals

The device is equipped with a stainless steel mesh-filter, which is located in the medium connection. If the device is exposed to a demanding environment or contaminated medium, the filter must be checked regularly. If necessary, the filter can be cleaned.

9.2 Inspect and clean the stainless steel mesh-filter

The inspection and possibly cleaning of the stainless steel meshfilter must be done at regular intervals. The inspection frequency and cleaning frequency depend on the measured medium.

If a contaminated medium is used, then clean the stainless steel mesh-filter immediately. If the stainless steel mesh-filter is contaminated, then replace it with a new one.

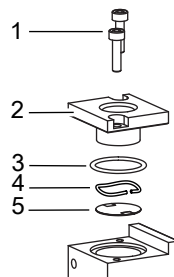

Fig. 23: Parts in contact with the medium

1 Screws	2 Flange plate
3 O-ring	4 Spring
5 Stainless steel mesh-filter	

- ▶ Position the device upright with the medium inlet at the top.
- ▶ With an hexagon key of size 2.5 mm, loosen the screws [1] and remove the flange plate [2].
- ▶ With a pair of tweezers, remove the O-ring [3], the wave spring [4] and the mesh filter [5].
- ▶ **CAUTION! Do not clean the mesh filter with tap water.** Clean the stainless steel mesh-filter [5] with acetone, isopropanol or compressed air.
- ▶ Dry the mesh filter.
- ▶ **CAUTION! Before mounting the parts back, make sure that the fine side of the mesh filter [5] faces the flange plate [2]**
- ▶ Mount the parts back in the correct order.
- ▶ Make sure that the mesh filter and the O-ring are seated flat and not tilted.

- ▶ Insert the flange plate [2] and the screws [1].
- ▶ Tighten the screws to a torque of 1.2 N·m (0,88 lbf·ft).

9.3 Calibration

The device is factory calibrated.

A regular check of the accuracy depends on the use and the individual requirements of the application. Mechanical wear, ageing of the materials, temperature changes, frequent use or contamination can affect the measuring accuracy over time. It is therefore advisable to calibrate measuring devices regularly to ensure precise measurement results at all times. The customer is responsible for determining the timing of the periodic inspection. We recommend checking the calibration after 12 months. If required, contact [Bürkert](#) for further information on calibrations and to arrange an appointment.



The calibration only applies to the primary measuring function of the measuring device. The secondary outputs are not covered by the calibration.

9.4 Replace the memory card

büS / CANopen variant

- ▶ De-energise the device.
- ▶ Remove the old memory card from its slot.
- ▶ Pay attention to the insertion direction of the memory card.

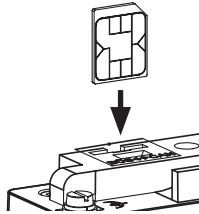

Fig. 24: Insertion direction of the memory card

- ▶ Grip the memory card with flat nose pliers and insert the memory card at an angle. Apply pressure to overcome the counter force of the spring contact.

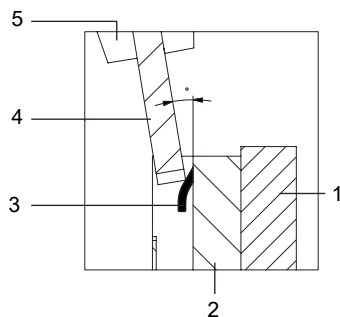

Fig. 25: Insertion of the memory card with flat-nose pliers

1 Electronic board	2 Holder of the memory card
3 Contact spring	4 Memory card
5 Flat-nose pliers	

- ▶ After overcoming the force of the spring, insert the memory card vertically.
- ▶ Restart the device to write the data on the new memory card. Possible problems related to the memory card are given in [Troubleshooting \[▶ 62\]](#)

Analogue variant | Industrial Ethernet variant | MFM RS485/Modbus RTU

- ▶ De-energise the device.
- ▶ With tweezers slightly push the memory card to the stop in the device and release. The old memory card comes out.
- ▶ Pay attention to the insertion direction of the memory card.

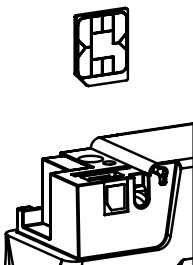

Fig. 26: Insertion direction of the memory card

- ▶ Push the new memory card in the slot until you hear a locking noise. If the memory card comes out, the locking failed.

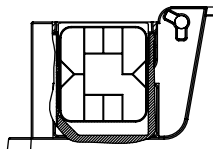

Fig. 27: Inserted memory card

- ▶ Restart the device to write the data on the new memory card. Possible problems related to the memory card are given in [Troubleshooting \[▶ 62\]](#)

büS / CANopen variant

The büS/CANopen variant supports the config-client if no memory card is used.

- ▶ Activate this functionality in the Bürkert communicator under **General settings > Parameter > Act as a configuration client > Yes.**

For detailed information, refer to the "Software manual | Central configuration management".

- ▶ Access the page [Type 8741](#)
- ▶ Scroll down to **Downloads > User Manuals**

10 Troubleshooting

10.1 Status indicator is red

Cause	Solution
The supply voltage is out of the error range. The device can be damaged.	<ul style="list-style-type: none"> ▶ Operate the device within the specifications. <p>If the status indicator does not change, then send the device back to Bürkert.</p>
The sensor, the internal memory or the device is defective.	<p>Maintenance is needed.</p> <ul style="list-style-type: none"> ▶ Contact the manufacturer.
Industrial Ethernet variant RS485/Modbus RTU variant	
No proper connection to the PLC.	<ul style="list-style-type: none"> ▶ Check the wiring. ▶ Check the status of the PLC.
EtherCAT variant	
	<ul style="list-style-type: none"> ▶ If the EtherCAT protocol is used, make sure the incoming cable (reception from the PLC) is inserted in the ETH1 port and the outgoing cable is inserted in the ETH2 port.
büS / CANopen variant	
büS error or CANopen-bus error, for example a short circuit.	<ul style="list-style-type: none"> ▶ Check the wiring.
büS / CANopen variant	
The device is connected to büS, but cannot find any fieldbus participants.	<ul style="list-style-type: none"> ▶ Check the wiring. ▶ Operate the device with other fieldbus participants.
büS / CANopen variant	
The device is connected to büS, but does not find the process value to be processed.	<ul style="list-style-type: none"> ▶ Make sure that the process value is correctly allocated. ▶ Check the assigned büS participant that is defective. ▶ Make sure that the assigned büS participant provides the cyclic data.
MFC	
Incorrect Autotune or Autotune aborted. After a restart of the device, the error will be reset.	<ul style="list-style-type: none"> ▶ Make sure that the medium flows through the device. ▶ Check the Q_{nom} of the device. ▶ Start the Autotune again. <p>After a restart of the device, the error will be reset.</p>

10.2 Status indicator is orange

Cause	Solution
A calibration procedure is in progress.	▶ Wait until the procedure is completed.
büS / CANopen variant	
The device is connected to büS and searches assigned fieldbus participant.	▶ Wait until the device has found assigned fieldbus participants.
büS / CANopen variant	
The device is connected to büS and is configured manually, but has no address.	▶ Wait up to one minute until the device assigns its address.
PROFINET variant	
PLC is in Stop mode.	▶ Activate the PLC.
MFC	
The Autotune is in progress.	▶ Wait until the procedure is completed.
MFC	
The operation mode of the device is set to Open-loop control mode , Manual set-point value or Analyze system .	Refer to Select the source that gives the set-point value [▶ 55]

10.3 Status indicator is yellow

Cause	Solution
One of the following values is out of specification. The sensor or the device can be damaged. <ul style="list-style-type: none"> the medium temperature the device temperature the supply voltage 	▶ Operate the device within the specifications. If the status indicator does not change, then send the device back to Bürkert.
büS / CANopen variant	
Other fieldbus participants use the same node ID.	▶ Assign an individual node ID to each fieldbus participant.
Industrial Ethernet variant	
A change of the Ethernet protocol is in progress.	▶ Wait until the procedure is completed.

Cause	Solution
MFC	
The set-point position for the actuator has (almost) reached 100%. The set-point value cannot be reached.	▶ Increase the inlet pressure or decrease the output pressure.
	▶ If the pressure drop in the pipe is too high, then reduce the pressure drop.
	▶ If the filters installed in the pipe are dirty, then clean the filters.

10.4 Status indicator is blue

Cause	Solution
Error in the internal memory.	Maintenance is needed. ▶ Contact the manufacturer.

10.5 Status indicator is off

Cause	Solution
The device is not energised.	▶ Check the wiring.
	▶ Make sure that the voltage supply is 24 V $\overline{\text{---}}$.
	▶ Make sure that the power supply source is working properly.

10.6 Status indicator goes out periodically

Cause	Solution
The power supply is intermittently dropping and the device restarts.	▶ Use a power supply with sufficient power output.
The voltage drop in the connecting cable is too high.	▶ Increase the cross-section of the cable and reduce the cable length.

10.7 Replacement device adopts none of the values from the defective device

Cause	Solution
The article number of the replacement device is different from the article number of the defective device.	▶ Use a replacement device that has the same article number than the defective device. Values can only be transferred between devices with the same article numbers.

Cause	Solution
The memory card is defective. The device could not write any values to the memory card.	<ul style="list-style-type: none"> ▶ Replace the memory card. Refer to Replace the memory card [▶ 59] .

10.8 Replacement device does not adopt all of the values from the defective device

Cause	Solution
The device description of the replacement device is different from the device structure of the defective device. Only the existing values of the defective device can be adopted by the replacement device.	<ul style="list-style-type: none"> ▶ Use the Bürkert Communicator to configure the new values of the replacement device.

10.9 No mass flow rate

Cause	Solution
The pipes are too large or not yet fully vented.	<ul style="list-style-type: none"> ▶ Vent the pipe. ▶ Change the pipe diameter.
The flow-rate value is below the cut-off limit.	<ul style="list-style-type: none"> ▶ If the cut-off limit is too high, decrease the value of the cut-off limit. Refer to Cut-off.

MFC

The device is not in the normal operation mode, refer to [Operation modes \[▶ 53\]](#).

The device is possibly running one of the functions described in [Select the source that gives the set-point value \[▶ 55\]](#)

- ▶ If the device is not running one of the functions described in [Select the source that gives the set-point value \[▶ 55\]](#), then check the other possible causes of the problem.

MFC

The set-point value is lower than the zero-point shut-off limit.

- ▶ Increase the set-point value until it is higher than 2% of the nominal flow rate.

10.10 Unstable measured value

Cause	Solution
Functional earth (FE) is not connected properly.	<ul style="list-style-type: none"> ▶ To connect the functional earth, use a green-and-yellow cable that is as short as possible. <p>the cable cross-section must be at least equal to the cross section of the power-supply cable. Refer to Connect the functional earth [▶ 45]</p>
MFC	
The residual ripple on the voltage supply is too high.	<ul style="list-style-type: none"> ▶ Use a supply voltage that conforms to the technical data given in Technical data [▶ 21]
MFC	
The device must compensate for irregularities in an unstable pressure supply caused, for example, by pumps.	<ul style="list-style-type: none"> ▶ Install a suitable pressure regulator in front of the device. ▶ Install a buffer tank to absorb the pressure fluctuations.
MFC	
The controller is unstable.	<ul style="list-style-type: none"> ▶ Run the Autotune function to adapt to the operating conditions.

10.11 Set-point value at 0 %, but medium still flows

Cause	Solution
MFC with proportional valve	
The connected actuator is a proportional valve and the operating pressure is above the tight sealing pressure of the proportional valve.	<ul style="list-style-type: none"> ▶ Reduce the operating pressure. ▶ To eliminate the defect, return the device to the manufacturer.
MFC Analogue	
The operating mode of the device is set to Open-loop control mode , and the actuator is open because the digital input triggers the opening of the actuator.	<ul style="list-style-type: none"> ▶ Set the device to the normal operating mode. <p>Refer to Normal operating mode (MFC) and to Select the source that gives the set-point value [▶ 55].</p> <ul style="list-style-type: none"> ▶ Check the operation of the digital input. <p>Refer to Digital input</p>

10.12 Set-point value at 0 %, no mass flow, but a non-zero mass flow rate is measured

Cause	Solution
MFC	
The installation position of the device is incorrect.	<ul style="list-style-type: none"> ▶ Install the device as recommended in Medium connection [▶ 31] ▶ Run the Autotune function to adapt to the operating conditions. ▶ Run a zero point adjustment. Refer to Zero point adjustment [▶ 51]
MFC	
The medium is different from the medium specified during the calibration.	<ul style="list-style-type: none"> ▶ Use the specified medium or send the device to the manufacturer for calibration with the new medium.

10.13 Set-point value is not reached

Cause	Solution
MFC	
The mesh filter is clogged.	<ul style="list-style-type: none"> ▶ Clean or replace the mesh filter. ▶ Run the Autotune function to adapt to the operating conditions.
MFC with proportional valve	
The outlet pressure is too high.	<ul style="list-style-type: none"> ▶ Make sure that the pipe diameters and the pipe lengths are adapted. ▶ If the medium connection pipes after the device are dirty, then clean them.
MFC with proportional valve	
The inlet pressure is too low.	<ul style="list-style-type: none"> ▶ Increase the inlet pressure to the calibration pressure value. ▶ Make sure that the pipe diameters and the pipe lengths are adapted.

10.14 Network status indicator

LED indicator	Meaning	Action
Link/Act-LED (green) fast blinking	Connection to the parent protocol layer is established.	-
Link/Act-LED (green) slow blinking (directly after restart)	Connection to the protocol layer is searched.	-
Link/Act-LED (green) slow blinking (20 s after restart)	No connection to the parent protocol layer.	▶ Check the cable.
Link/Act-LED (green) is OFF.	No connection to the network.	▶ Check the cable.
Link-LED (yellow) is ON	Connection to the network is established.	-
Link LED (yellow) is not lit	Not connected to network.	▶ Check cable.

Tab. 19: Meaning of the LED indicator

11 Uninstallation

11.1 Dismantling

- ▶ Relieve the medium pressure in the installation.
- ▶ Flush the device with a neutral medium (for example nitrogen)
- ▶ Relieve the flushing medium pressure in the installation.
- ▶ De-energise the device.
- ▶ Remove the electrical wiring.
- ▶ Disconnect the medium connections.
- ▶ Remove the device.

12 Spare parts and accessories



Risk of injury and/or damage due to incorrect parts.

- ▶ Use only original accessories and original spare parts from Bürkert.



Order the parts directly on our [eShop](#).

12.1 Electrical accessories

- ▶ For further accessories, refer to the data sheet.

büS / CANopen variant

USB-büS-interface set, including power supply	772426
büS cable, 50 m	772413
büS cable, 100 m	772414
4-pin plug connector	565876
4-pin plug connector with integrated 120-Ohm terminal resistor	566066
Memory card	on request

Industrial Ethernet variant

USB-büS-interface set, without power supply	772551
Memory card	on request

Analogue variant

USB-büS-interface set, without power supply	772551
Memory card	on request
D-sub DE-9 female connector with 5 m cable, with stripped end	580882
D-sub DE-9 female connector with 10 m cable, with stripped end	580883

RS485/Modbus RTU variant

USB-büS-interface set, without power supply	772551
Memory card	on request
D-sub DE-9 female connector with 5 m cable, with stripped end	580882
D-sub DE-9 female connector with 10 m cable, with stripped end	580883

12.2 Compression fittings for a device with G-internal-threaded connections

The threaded pipe-connection plates of the device obey standard DIN ISO 228/1. If the pipe fittings are not delivered with the device, then choose pipe fittings that are adapted to the medium connection of the device. Also order the seal depending on the medium connection and the pipe diameter.

Device internal-threaded connection in accordance with DIN ISO 228/1	Pipe diameter	Article number	
		Stainless steel compression-fitting	Seal (1 piece)
G 1/4	6 mm	901538	901575 (Copper)
G 1/4	8 mm	901540	
G 1/4	1/4"	901551	901579 (Rubber steel)
G 1/4	3/8"	901553	

Tab. 20: Stainless steel compression fittings and related seals

12.3 Additional software

Bürkert Communicator	Download from country.burkert.com
----------------------	---

Tab. 21: Documentation and software

13 Logistics

13.1 Transport and storage

- ▶ Protect the device against moisture and dirt in the original packaging during transportation and storage.
- ▶ Avoid UV radiation and direct sunlight.
- ▶ Protect connections, if present, from damage with protective caps.
- ▶ Observe the permitted storage temperature.
- ▶ Remove cables, connectors, external filters and installation equipment.
- ▶ Clean and vent contaminated devices.

13.2 Return



No work or tests will be carried out on the device until a valid Contamination Declaration has been received.

- ▶ To return a used device to Bürkert, contact the Bürkert sales office. A return number is required.

13.3 Disposal

Environmentally friendly disposal



- ▶ Follow national regulations regarding disposal and the environment.
- ▶ Collect electrical and electronic devices separately and dispose of them as special waste.

Further information at country.burkert.com