

# Type 8020

Flowmeter with paddle wheel



## Operating Instructions

We reserve the right to make technical changes without notice.

© Bürkert SAS 2010-2026

Technical documentation 2602/05\_GBen\_00419607\_1186118539\_1186282123 / Original EN

# Table of contents

<b>1</b>	<b>About this document</b>	<b>4</b>
1.1	Symbols	4
1.2	Terms and abbreviations	5
1.3	Manufacturer	5
<b>2</b>	<b>Safety</b>	<b>6</b>
2.1	Intended use	6
2.2	Safety instructions	6
<b>3</b>	<b>Description</b>	<b>8</b>
3.1	Construction	8
3.2	Measuring principle	8
3.3	Type label	8
3.4	Available versions of the electronic module	9
<b>4</b>	<b>Technical data</b>	<b>10</b>
4.1	Standards and directives	10
4.2	Operating conditions	10
4.3	Conformity to the Pressure Equipment Directive	10
4.4	Mechanical data	11
4.5	Dimensions	11
4.6	Fluid data	11
4.7	Electrical data	12
<b>5</b>	<b>Installation and commissioning</b>	<b>14</b>
5.1	Safety instructions	14
5.2	Installation onto the pipe	15
5.3	Installation of the 8020 on the S020 fitting	17
5.4	Wiring	17
5.5	Assembling the female connector	18
<b>6</b>	<b>Maintenance</b>	<b>22</b>
6.1	Safety instructions	22
6.2	Cleaning	22
6.3	Cleaning the flow sensor	23
<b>7</b>	<b>Accessories</b>	<b>24</b>
<b>8</b>	<b>Logistics</b>	<b>25</b>
8.1	Transport and storage	25
8.2	Return	25
8.3	Disposal	25

# 1 About this document

The document is an important part of the product and guides the user to safe installation and operation. The information and instructions in this document are binding for the use of the product.

- ▶ Before using the product for the first time, read and observe the whole safety chapter.
- ▶ Before starting any work on the product, read and observe the respective sections of the document.
- ▶ Keep the document available for reference and give it to the next user.
- ▶ Contact the Bürkert sales office for any questions.



Further information concerning the product at [Products](#).

- ▶ Enter the article number from the type label in the search bar.

The illustrations in these instructions may vary depending on the product variant.

## 1.1 Symbols



### **DANGER!**

Warns of a danger that leads to death or serious injuries.



### **WARNING!**

Warns of a danger that can lead to death or serious injuries.



### **CAUTION!**

Warns of a danger that can lead to minor injuries.

### **NOTICE!**

Warns of property damage on the product or the installation.



Indicates important additional information, tips and recommendations.



Refers to information in this document or in other documents.

- ▶ Indicates a step to be carried out.

✓ Indicates a result.

**Menu** Indicates a software user-interface text.

## 1.2 Terms and abbreviations

The terms and abbreviations are used in this document to refer to following definitions.

---

Device	Flowmeter Type 8020.
--------	----------------------

---

## 1.3 Manufacturer

Bürkert SAS

20, rue du Giessen

67220 TRIEMBACH-AU VAL

FRANCE

The contact addresses are available at [Contact](#).



Need more information or additional products?

► Explore the full range of products on our [eShop](#).

---

## 2 Safety

### 2.1 Intended use

Use of the device that does not comply with the instructions could present risks to people, nearby installations and the environment.

The flowmeter type 8020 is exclusively intended to measure the flow rate of neutral or slightly aggressive liquids free of solid particles.

- ▶ This device must be protected against electromagnetic interference, ultraviolet rays and, when installed outdoors, the effects of climatic conditions.
- ▶ This device must be used in compliance with the characteristics and commissioning and use conditions specified in the contractual documents and in the user manual.
- ▶ Requirements for the safe and proper operation of the device are proper transport, storage and installation, as well as careful operation and maintenance.
- ▶ Only use the device as intended.

### 2.2 Safety instructions

This safety information does not take into account any contingencies or occurrences that may arise during installation, use and maintenance of the device.

The operating company is responsible for the respect of the local safety regulations including for the staff safety.

**Danger due to high pressure in the installation.**

**Danger due to electrical voltage.**

**Danger due to high temperatures of the fluid.**

**Danger due to the nature of the fluid.**

#### Various dangerous situations

- ▶ Prevent any unintentional power supply switch-on.
- ▶ Ensure that installation and maintenance work are carried out by qualified, authorised personnel in possession of the appropriate tools.
- ▶ Guarantee a set or controlled restarting of the process, after a power supply interruption.
- ▶ Use the device only if in perfect working order and in compliance with the instructions provided in the operating instructions.
- ▶ Observe the general technical rules when installing and using the device.
- ▶ Do not use this device in explosive atmospheres.
- ▶ Do not use fluid that is incompatible with the materials the device is made of.
- ▶ Do not use this device in an environment incompatible with the materials it is made of.
- ▶ Do not subject the device to mechanical loads.
- ▶ Do not make any modifications to the device.

### The device may be damaged by the fluid in contact with.

- ▶ Systematically check the chemical compatibility of the component materials of the device and the fluids likely to come into contact with it (for example: alcohols, strong or concentrated acids, aldehydes, alkaline compounds, esters, aliphatic compounds, ketones, halogenated aromatics or hydrocarbons, oxidants and chlorinated agents).

### Elements / Components sensitive to electrostatic discharges

- ▶ This device contains electronic components sensitive to electrostatic discharges. They may be damaged if they are touched by an electrostatically charged person or object. In the worst case scenario, these components are instantly destroyed or go out of order as soon as they are activated.
- ▶ To minimise or even avoid all damage due to an electrostatic discharge, take all the precautions described in the EN 61340-5-1 norm.
- ▶ Do not touch any of the live electrical components.

## 3 Description

### 3.1 Construction

The device is made up of an electronic module and of a flow sensor. The device can be installed in any pipe from DN20 (except for DN20 specified in [Installation onto the pipe \[► 15\]](#)) to DN400.

The device has, depending on the version, 1 NPN transistor output, 2 transistor outputs, NPN and PNP, or 1 sinus output (coil output).

Electrical connection is made via a male fixed connector.

### 3.2 Measuring principle

The circulation of fluid within the pipe causes the paddle wheel of the sensor to rotate. The flowmeter detects the rotation of the paddle-wheel and generates a signal which frequency  $f$  is proportional to the flow rate  $Q$ , using the formula  $f = KxQ$ .

$f$  = frequency in Hertz (Hz)

$K$  = K factor of the S020 fitting used, in pulse/litre

$Q$  = flow rate in litre/second

### 3.3 Type label

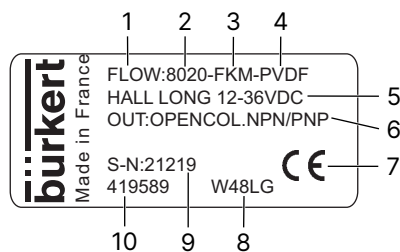

1 Measured quantity	2 Type
3 Sealing material	4 Material of the flow sensor frame
5 Version of the flow sensor and, when required, power supply	6 Output data
7 CE marking	8 Manufacture code
9 Serial number	10 Article number

### 3.4 Available versions of the electronic module

The electrical connection of all the devices is made through a male fixed connector.

Supply voltage	Output	Flow sensor	Article number
12...36 V DC filtered and regulated	2 transistors, NPN and PNP	Hall, short	419 587
		Hall, long	419 589
energized via the Bürkert transmitter the flow sensor is connected to	1 NPN transistor	Hall Low Power, short	419 591
		Hall Low Power, long	419 593
without	1 sinus output	Coil, short	419 583
		Coil, long	419 585

## 4 Technical data

### 4.1 Standards and directives

This product complies with the legal requirements applicable at the time of placing on the market and has been developed and tested in accordance with the relevant European directives/regulations and harmonized standards. The conformity is documented and, if necessary, supported by evidence. The EU Declaration of Conformity can be found behind the respective type on the home page [country.burkert.com](http://country.burkert.com)

### 4.2 Operating conditions

Ambient temperature	-15 °C...+60 °C
Air humidity	< 80 %, non condensated
Protection rating acc. to EN 60529	IP65, female connector wired, plugged and tightened
Storage temperature	-15...+60°C

### 4.3 Conformity to the Pressure Equipment Directive

- ▶ Make sure that the device materials are compatible with the fluid.
- ▶ Make sure that the pipe DN is adapted for the device.
- ▶ Observe the fluid nominal pressure (PN) for the device. The nominal pressure (PN) is given by the device manufacturer.

The device conforms to Article 4, Paragraph 1 of the Pressure Equipment Directive 2014/68/EU under the following conditions:

#### Device used on a pipe

(PS = maximum admissible pressure in bar; DN = nominal dimension of the pipe, no unit)

Type of fluid	Conditions
Fluid group 1, Article 4, Paragraph 1.c.i	DN ≤ 25
Fluid group 2, Article 4, Paragraph 1.c.i	DN ≤ 32 or PSxDN ≤ 1000
Fluid group 1, Article 4, Paragraph 1.c.ii	DN ≤ 25 or PSxDN ≤ 2000
Fluid group 2, Article 4, Paragraph 1.c.ii	DN ≤ 200 or PS ≤ 10 or PSxDN ≤ 5000

## 4.4 Mechanical data

Housing	PE
Nut	PC
Female connector type 2518 / screw / seal	PA / Stainless steel / NBR
Frame of the flow sensor and paddle wheel	PVDF
Axis and bearings	Ceramic
Gasket	FKM (EPDM optional)

## 4.5 Dimensions

Refer to the related datasheet at [Type 8020](#)

## 4.6 Fluid data

Fluid temperature	The fluid temperature may be restricted by the fluid pressure: Refer to the fluid temperaturepressure dependency curves for the device. See following figure.
<ul style="list-style-type: none"> <li>with fitting S020 in metal or PVDF</li> </ul>	-15 °C...+80 °C
<ul style="list-style-type: none"> <li>with fitting S020 in PP</li> </ul>	0 °C...+80 °C
<ul style="list-style-type: none"> <li>with fitting S020 in PVC</li> </ul>	0 °C...+50 °C
Flow rate measuring range	
<ul style="list-style-type: none"> <li>Hall and Hall Low Power versions</li> </ul>	0.3...10 m/s
<ul style="list-style-type: none"> <li>Sinus version</li> </ul>	0.5...10 m/s
Measurement deviation	
<ul style="list-style-type: none"> <li>with standard K-factor</li> </ul>	2.5 % of the measured value <sup>1)</sup>
<ul style="list-style-type: none"> <li>with Teach-In</li> </ul>	+1 % of the measured value <sup>1)</sup>
Linearity	±0.5 % of the full scale (10 m/s)
Repeatability	±0.4 % of the measured value <sup>1)</sup>

<sup>1)</sup> Determined under following reference conditions: medium = water, water and ambient temperatures 20 °C, min. upstream and downstream distances respected, appropriate pipe dimensions

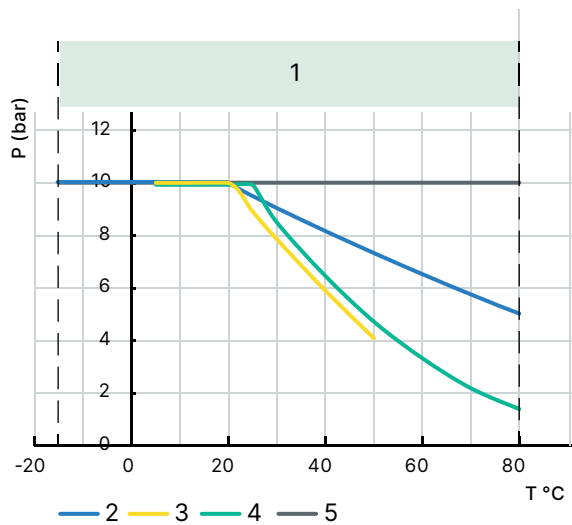

Fig. 1: Fluid temperature-pressure dependency curves

1 Application range for complete device (fitting Type S020 + flowmeter Type 8020)	2 PVDF
3 PVC	4 PP
5 Metal	

## 4.7 Electrical data

Supply voltage	
• Hall version	12...36 V DC, filtered and regulated
• Hall Low Power version	12...36 V DC, via transmitter the device is connected to
Current consumption	
• Hall version	50 mA max.
• Hall Low Power version	0.8 mA max.
Protection against polarity reversal	yes
Protection against spike voltages	yes
Protection against short circuits	yes
Transistor output (Hall version)	pulse output, NPN and PNP, open collector, max. 100 mA, frequency up to 300 Hz, duty cycle 1/2 ±10 % NPN output: 0.2...36 V DC PNP output: supply voltage
Transistor output (Hall Low Power version)	pulse output, NPN, open collector, max. 10 mA, frequency up to 300 Hz, duty cycle 1/2 ±10 %
Coil output	sine-wave signal, frequency up to 300 Hz, about 2.8 mV peak-to-peak/Hz under a 50 kW load

## Electrical connection

Type of connector	Cable type
2518 female connector (supplied), with order code 572264	For the Hall and Hall Low Power versions: <ul style="list-style-type: none"><li>• shielded, max. 50 m</li><li>• 5...8 mm in diameter</li><li>• wires, 0.25...1.5 mm<sup>2</sup> in cross section</li></ul> <hr/> <p>For the sinus version:</p> <ul style="list-style-type: none"><li>• shielded, max. 10 m</li><li>• 5...8 mm in diameter</li><li>• wires, 0.25...1.5 mm<sup>2</sup> in cross section</li></ul> <hr/>

## 5 Installation and commissioning

### 5.1 Safety instructions

#### **DANGER!**

Risk of injury due to high pressure in the installation.

- ▶ Stop the circulation of fluid, cut off the pressure and drain the pipe before loosening the process connections.

#### **DANGER!**

Risk of injury due to high fluid temperatures.

- ▶ Use safety gloves to handle the device.
- ▶ Stop the circulation of fluid, and drain the pipe before loosening the process connections.

#### **DANGER!**

Risk of injury due to the nature of the fluid.

- ▶ Respect the prevailing regulations on accident prevention and safety relating to the use of hazardous products.

#### **WARNING!**

Risk of injury due to electrical voltage.

- ▶ Shut down and isolate the electrical power source before carrying out work on the system.
- ▶ Observe all applicable accident protection and safety regulations for electrical equipment.

#### **WARNING!**

Risk of injury due to non-conforming installation.

- ▶ The electrical and fluid installation can only be carried out by qualified and skilled staff with the appropriate tools.
- ▶ Observe mounting instructions of the fitting.
- ▶ Risk of injury due to an uncontrolled restart.
- ▶ Ensure that the restart of the installation is controlled after any interventions on it.

#### **WARNING!**

Risk of injury if the fluid pressure/ temperature dependency is not respected.

- ▶ Take account of fluid temperature-pressure dependency according to the nature of the materials the fitting is made of (see figure in [Fluid data](#) [▶ 11]).
- ▶ Comply with the pressure equipment directive 2014/68/EU.

 **WARNING!**

**Danger due to non-conforming commissioning.**

Non-conforming commissioning may lead to injuries and damage the product and its surroundings.

- ▶ Before commissioning, make sure that the staff in charge have read and fully understood the contents of the manual.
- ▶ In particular, observe the safety recommendations and intended use.
- ▶ The device / the installation must only be commissioned by suitably trained staff.

**NOTICE!**

**Risk of damage to the device due to the environment**

- ▶ Protect this device against electromagnetic interference, ultraviolet rays and, when installed outdoors, the effects of the climatic conditions.



To make sure the device operates correctly, plug in and tighten the connector.

## 5.2 Installation onto the pipe

- ▶ Choose a fitting appropriate to the velocity and the flow rate of the fluid inside the pipe, refer to the following graph. The graph is used to determine the DN of the pipe and the fitting appropriate to the application, according to the fluid velocity and the flow rate.
- ▶ Install the fitting on the pipe as described in the operating instructions of the fitting used.

The graph is used to determine the DN of the pipe and the fitting appropriate to the application, according to the fluid velocity and the flow rate.

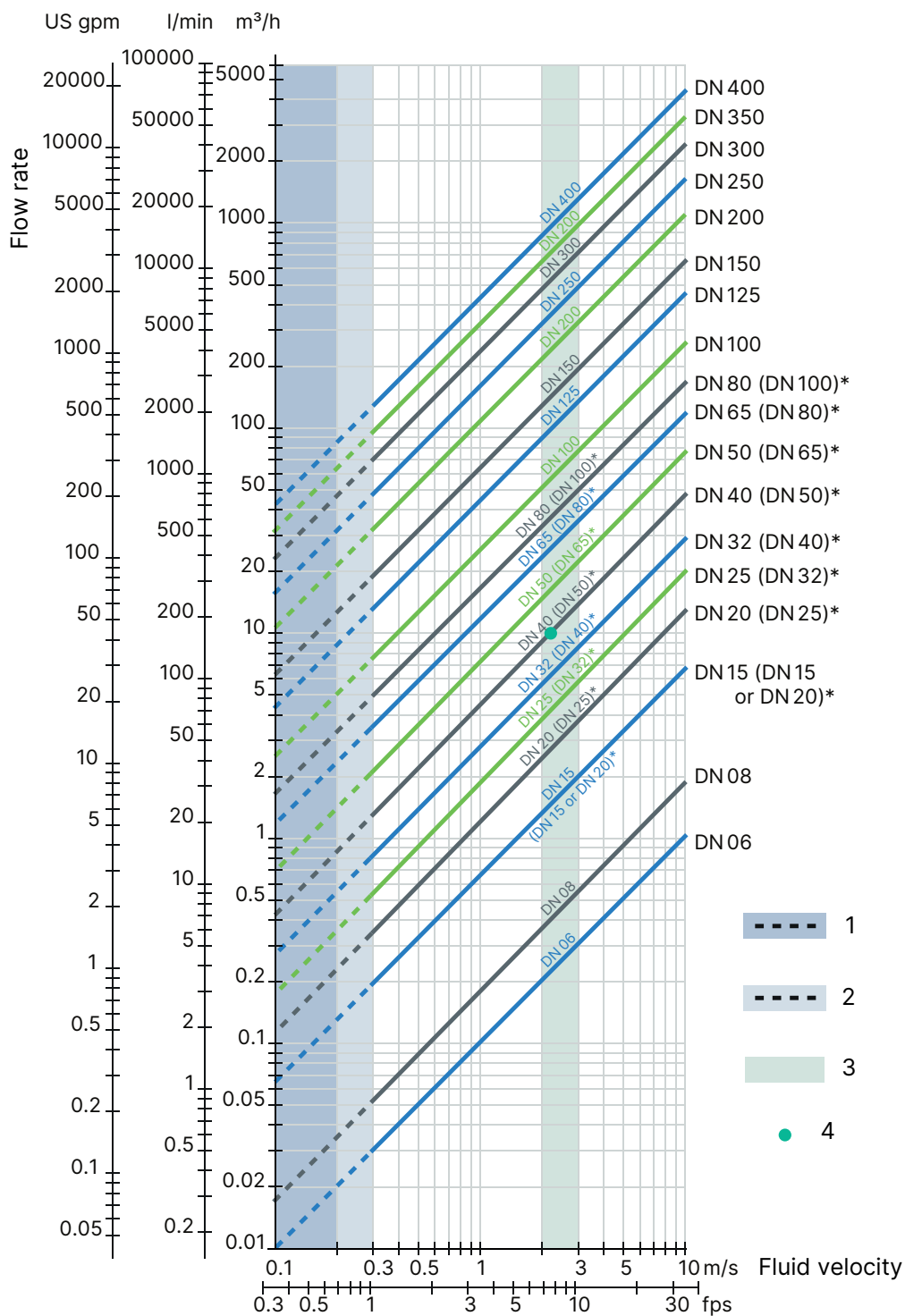

1 Not recommended, if used with Type 8041 or 8045

2 Not recommended, if used with Type 8020, 8025 or 8026

3 Optimal flow rate

4 Diameter of example 1 and example 2

**\* Note**

- For the fittings listed below, the corresponding nominal size in the bracket must be used:  
– External threads according to SMS 1145

- Weld ends according to SMS 3008, BS4825-1/ASME BPE/DIN 11866 series C or DIN 11850 series 2/DIN 11866 series A/ DIN EN 10357 series A
- Clamp according to SMS 3017, BS 4825-3/ASME BPE or DIN 32676 series A
- For all other fittings, the corresponding nominal diameter without bracket applies.

Example 1	Example 2 With external threads according to SMS 1145
<ul style="list-style-type: none"> <li>• Nominal flow: 10 m<sup>3</sup>/h</li> <li>• Optimal flow rate: 2...3 m/s</li> </ul>	<ul style="list-style-type: none"> <li>• Nominal flow: 10 m<sup>3</sup>/h</li> <li>• Optimal flow rate: 2...3 m/s</li> </ul>
Result: Select a pipe size of DN 40	Result: Select a pipe size of DN 50

### 5.3 Installation of the 8020 on the S020 fitting

- ▶ Insert the nut on the fitting.
- ▶ Insert the snap ring into the groove.
- ▶ Check that there is a seal on the device and that it is not damaged. Replace the seal if necessary.
- ▶ Slowly insert the device into the fitting.

If the mounting is correctly done, the device cannot be turned around anymore.

- ▶ Hand lock the assembly with the nut.

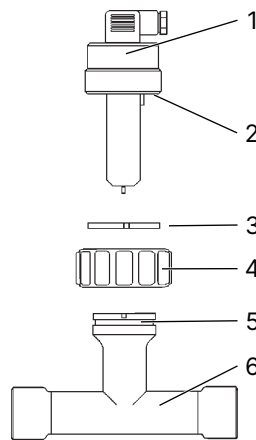

Fig. 2: Installation of the flowmeter on the S020 fitting

1 Device	2 Seal
3 Snap ring	4 Nut
5 Groove	6 Fitting

### 5.4 Wiring

#### DANGER!

Risk of injury due to electrical discharge

- ▶ Shut down and isolate the electrical power source before carrying out work on the system.
- ▶ Observe all applicable accident protection and safety regulations for electrical equipment.

**NOTICE!**

**Protect the power supply**

- ▶ Protect the power supply with a correctly rated fuse if it is not protected by default.

**NOTICE!**

- ▶ Use a shielded cable with an operating temperature limit higher than +80 °C.
- ▶ Use a high quality electrical power supply (filtered and regulated).
- ▶ Do not install the cable near high voltage or high frequency cables.
- ▶ If a closed installation cannot be avoided, maintain a minimum distance of 30 cm.

## 5.5 Assembling the female connector

- ▶ Unscrew the pressure screw and remove the pressure ring and the seal.
- ▶ Remove contact holder from the cover.
- ▶ Insert the cable into pressure screw, through the pressure ring, through the seal and finally through the cover.
- ▶ Connect the wires on the contact holder.
- ▶ Position the contact holder in steps of 90° then put it back into cover, pulling gently on the cable so that the wires do not clutter the housing.
- ▶ Tighten the pressure screw (1.5...2 Nm).
- ▶ Place the seal between the connector and the fixed connector on the device and then plug the type 2518 connector into the fixed connector.
- ▶ Insert and tighten the central screw (0.5...0.6 Nm) to ensure tightness and correct electrical contact.

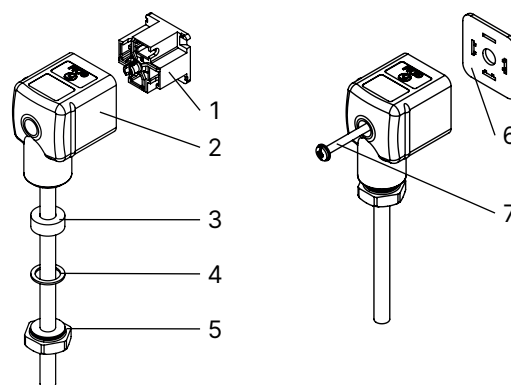

Fig. 3: Assembling the female connector type 2518

1 Contact holder	2 Cover
3 Seal	4 Pressure ring
5 Pressure screw	6 Seal
7 Central screw	

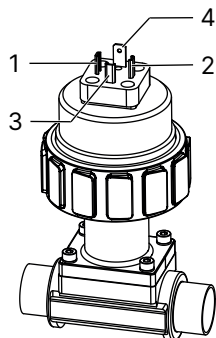

Fig. 4: Pin assignment of the fixed connector, Hall version

1 V+ (12...36 V DC)	2 NPN transistor output
3 0 V DC	4 PNP transistor output

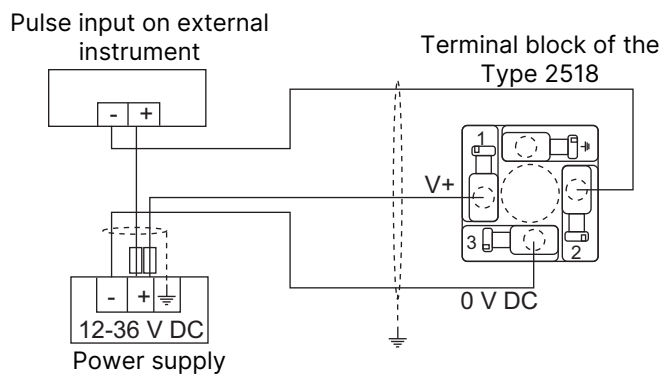

Fig. 5: NPN wiring of the Hall version

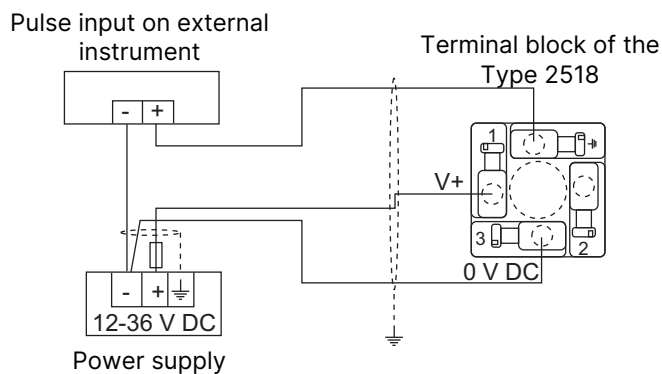

Fig. 6: PNP wiring of the Hall version

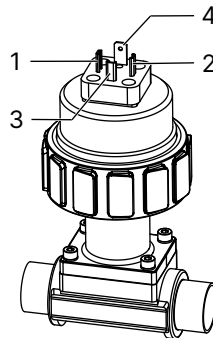

Fig. 7: Pin assignment of the fixed connector, Hall Low Power version

1 V+ (12...36 V DC)	2 NPN transistor output
3 0 V DC	4 Not connected

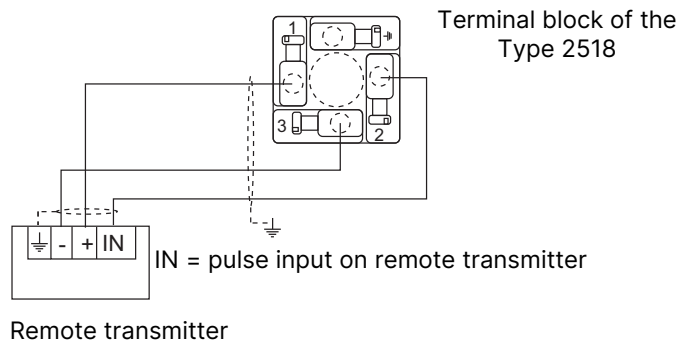

Fig. 8: NPN wiring of the Hall Low Power version

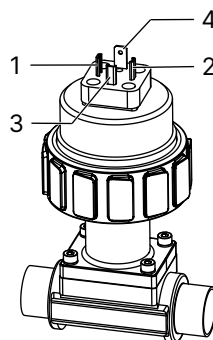

Fig. 9: Pin assignment of the fixed connector, sinus version

1 Not connected	2 Sinus output
3 Sinus output	4 Not connected

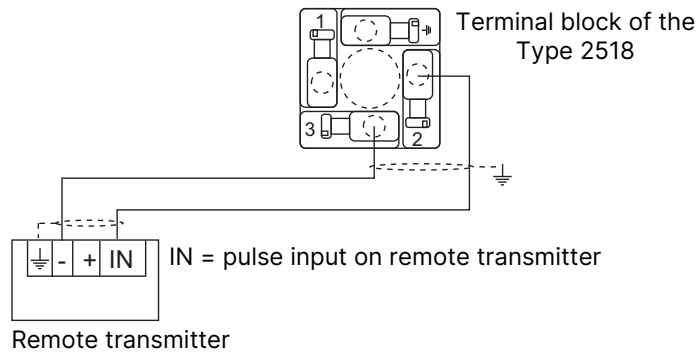

Fig. 10: Wiring of the sinus output of a sinus version

## 6 Maintenance

### 6.1 Safety instructions

#### **DANGER!**

Risk of injury due to electrical voltage.

- ▶ Shut down and isolate the electrical power source before carrying out work on the system.
- ▶ Observe all applicable accident protection and safety regulations for electrical equipment.

#### **DANGER!**

Risk of injury due to high pressure in the installation.

- ▶ Stop the circulation of fluid, cut off the pressure and drain the pipe before loosening the process connections.

#### **DANGER!**

Risk of injury due to high fluid temperatures.

- ▶ Use safety gloves to handle the device.
- ▶ Stop the circulation of fluid, and drain the pipe before loosening the process connections.
- ▶ Keep all easily flammable material and fluid away from the device.

#### **DANGER!**

Risk of injury due to the nature of the fluid.

- ▶ Respect the prevailing regulations on accident prevention and safety relating to the use of aggressive fluids.

#### **WARNING!**

Risk of injury due to non-conforming maintenance.

- ▶ Maintenance must only be carried out by qualified and skilled staff with the appropriate tools.
- ▶ Ensure that the restart of the installation is controlled after any interventions.

### 6.2 Cleaning

#### **NOTICE!**

Warns of property damage on the product or the installation.

- ▶ Clean the device with a cloth slightly dampened with water or a cleaning liquid compatible with the materials the device is made of.

## 6.3 Cleaning the flow sensor

### NOTICE!

The flow sensor may be damaged by the cleaning liquid.

- ▶ Use a cleaning product that is compatible with the materials the flow sensor is made of.
- ▶ Do not use any abrasive acting materials.

### NOTICE!

After cleaning the flow sensor:

- ▶ Rinse the flow sensor.
- ▶ Check the seal and replace it if necessary.

## 7 Accessories



### CAUTION!

Risk of injury and/or damage caused by the use of unsuitable parts.

Incorrect accessories and unsuitable spare parts may cause injuries and damage the device and the surrounding area.

► Use only original accessories and original spare parts from Bürkert.

Accessories	Article number
Female connector with cable gland (type 2518)	572 264
Female connector (type 2509) with NPT 1/2" reduction, without cable gland	162 673
Set with seals (1 FKM + 1 EPDM)	552 111

## 8 Logistics

### 8.1 Transport and storage

- ▶ Protect the device against moisture and dirt in the original packaging during transportation and storage.
- ▶ Avoid UV radiation and direct sunlight.
- ▶ Protect connections, if present, from damage with protective caps.
- ▶ Observe the permitted storage temperature.

### 8.2 Return



---

No work or tests will be carried out on the device until a valid Contamination Declaration has been received.

---

- ▶ To return a used device to Bürkert, contact the Bürkert sales office. A return number is required.

### 8.3 Disposal

Environmentally friendly disposal



- ▶ Follow national regulations regarding disposal and the environment.
- ▶ Collect electrical and electronic devices separately and dispose of them as special waste.

Further information at [country.burkert.com](https://country.burkert.com)