

# Type 8012

Flowmeter with paddle wheel for continuous flow measurement

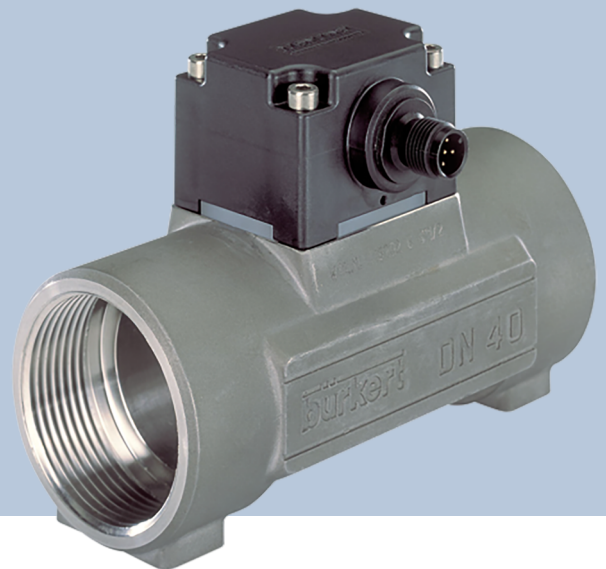

## Operating Instructions

We reserve the right to make technical changes without notice.

© Bürkert SAS 2012 - 2026

Technical documentation 2602/05\_GBen\_00563643\_1088140555\_9007200342972299 / Original EN

# Table of contents

<b>1</b>	<b>About this document</b>	<b>5</b>
1.1	Symbols	5
1.2	Terms and abbreviations	6
1.3	Manufacturer	6
<b>2</b>	<b>Safety</b>	<b>7</b>
2.1	Intended use	7
2.2	Safety instructions	7
<b>3</b>	<b>Product description</b>	<b>9</b>
3.1	Product overview	9
3.1.1	Version with pulse output	10
3.1.2	Version with pulse output and current output	11
3.2	Type label	12
3.3	Article numbers for the basic versions of the SE12 module	13
<b>4</b>	<b>Technical data</b>	<b>15</b>
4.1	Standards and directives	15
4.2	Conditions of use	15
4.3	Conformity to standards and directives	15
4.4	Mechanical data	16
4.5	Dimensions	16
4.6	Fluid data	17
4.7	Electrical data	18
4.8	Electrical connections	18
4.9	K factors	19
<b>5</b>	<b>Installation and wiring</b>	<b>22</b>
5.1	Safety instructions	22
5.2	Installation onto the pipe	24
5.2.1	Recommendations for installing the 8012 on the pipe	24
5.2.2	Installing a device with welding ends	27
5.2.3	Installing a device with Clamp connections	27
5.2.4	Installing a device with flange connections	27
5.3	Graphs	28
5.4	Electrical wiring	29
5.4.1	Assembling the M12 female connector	30
5.4.2	Wiring a version with adjustable M12 fixed connector	31
5.4.3	Wiring a version with cable gland	33
<b>6</b>	<b>Commissioning</b>	<b>35</b>
6.1	Safety instructions	35
<b>7</b>	<b>Adjustment and functions</b>	<b>36</b>
7.1	Safety instructions	36
7.2	Pulse output	36
7.2.1	Frequency proportional to a volume	36
7.2.2	Switching function	36
7.2.3	Detection of a change in the fluid direction (only 8012 with optical sensor)	39
7.3	Current output	40

7.3.1	Extension of the current range	40
7.3.2	Conversion of the frequency into a flow rate	40
7.3.3	Current attenuation variations	41
<b>8</b>	<b>Maintenance and troubleshooting</b>	<b>42</b>
8.1	Safety instructions	42
8.2	Cleaning	42
8.3	Replacing the seal	43
8.4	Problem solving	43
<b>9</b>	<b>Spare parts and accessories</b>	<b>45</b>
<b>10</b>	<b>Logistics</b>	<b>47</b>
10.1	Transport and storage	47
10.2	Return	47
10.3	Disposal	47

# 1 About this document

The document is an important part of the product and guides the user to safe installation and operation. The information and instructions in this document are binding for the use of the product.

- ▶ Before using the product for the first time, read and observe the whole safety chapter.
- ▶ Before starting any work on the product, read and observe the respective sections of the document.
- ▶ Keep the document available for reference and give it to the next user.
- ▶ Contact the Bürkert sales office for any questions.



Further information concerning the product at [Products](#).

- ▶ Enter the article number from the type label in the search bar.

The illustrations in these instructions may vary depending on the product variant.

## 1.1 Symbols



### **DANGER!**

Warns of a danger that leads to death or serious injuries.



### **WARNING!**

Warns of a danger that can lead to death or serious injuries.



### **CAUTION!**

Warns of a danger that can lead to minor injuries.

### **NOTICE!**

Warns of property damage on the product or the installation.



Indicates important additional information, tips and recommendations.



Refers to information in this document or in other documents.

- ▶ Indicates a step to be carried out.

✓ Indicates a result.

**Menu** Indicates a software user-interface text.

## 1.2 Terms and abbreviations

The terms and abbreviations are used in this document to refer to following definitions.

---

Product	Type 8012 flowmeter
---------	---------------------

---

## 1.3 Manufacturer

Bürkert SAS

20, rue du Giessen

67220 TRIEMBACH-AU VAL

FRANCE

The contact addresses are available at [Contact](#).



Need more information or additional products?

- ▶ Explore the full range of products on our [eShop](#).

## 2 Safety

### 2.1 Intended use

Use of the flowmeter that does not comply with the instructions could present risks to people, nearby installations and the environment.

The 8012 flowmeter with magnetic sensor is intended to measure the flow rate of neutral or slightly aggressive liquids free of solid particles.

The 8012 flowmeter with optical sensor is intended exclusively for measuring the flow rate of liquids that allow the passage of infrared rays.

- ▶ This device must be protected against electromagnetic interference, ultraviolet rays and, when installed outdoors, the effects of climatic conditions.
- ▶ This device must be used in compliance with the characteristics and commissioning and use conditions specified in the contractual documents and in the Operating Instructions.
- ▶ Requirements for the safe and proper operation of the device are proper transport, storage and installation, as well as careful operation and maintenance.
- ▶ Only use the device as intended.

### 2.2 Safety instructions

This safety information does not take into account any contingencies or occurrences that may arise during installation, use and maintenance of the product.

The operating company is responsible for the respect of the local safety regulations including for the staff safety.

**Danger due to high pressure in the installation.**

**Danger due to electrical voltage.**

**Danger due to high temperatures of the fluid.**

**Danger due to the nature of the fluid.**

#### Various dangerous situations

To avoid injury take care:

- ▶ to prevent any unintentional power supply switch-on.
- ▶ to ensure that installation and maintenance work are carried out by qualified, authorised personnel in possession of the appropriate tools.
- ▶ to guarantee a defined or controlled restarting of the process, after a power supply interruption.
- ▶ to use the device only if in perfect working order and in compliance with the instructions provided in the Operating Instructions.
- ▶ to observe the general technical rules when installing and using the device.
- ▶ not to use this device in explosive atmospheres.
- ▶ not to use the device for the measurement of gas flow rates.
- ▶ not to use fluid that is incompatible with the materials the device is made of.
- ▶ not to use this device in an environment incompatible with the materials it is made of.

- ▶ not to subject the device to mechanical loads (e.g. by placing objects on top of it or by using it as a step).
- ▶ not to make any external modifications to the device. Do not paint any part of the device.

The device may be damaged by the fluid in contact with.

- ▶ Systematically check the chemical compatibility of the component materials of the device and the fluids likely to come into contact with it (for example: alcohols, strong or concentrated acids, aldehydes, alkaline compounds, esters, aliphatic compounds, ketones, halogenated aromatics or hydrocarbons, oxidants and chlorinated agents).

#### Elements / Components sensitive to electrostatic discharges

- ▶ This device contains electronic components sensitive to electrostatic discharges. They may be damaged if they are touched by an electrostatically charged person or object. In the worst case scenario, these components are instantly destroyed or go out of order as soon as they are activated.
- ▶ To minimise or even avoid all damage due to an electrostatic discharge, take all the precautions described in the EN 61340-5-1 norm.
- ▶ Also ensure that you do not touch any of the live electrical components.

## 3 Product description

### 3.1 Product overview

The 8012 flowmeter comprises the SE12 electronics incorporating the measuring paddle-wheel and an S012 fitting allowing the device to be fitted to all types of pipes from DN6 to DN65.

The sensor detects the rotation of the paddle-wheel; it generates a signal in which the frequency  $f$  is proportional to the rotation frequency of the paddle-wheel.

The electronic module is fitted with 2 LEDs visible by transparency on the side of the housing:

- A green LED is on when the device is energized (the paddle-wheel is not running) and then flashes proportionally to the rotation frequency of the paddle-wheel.
- A red LED signals a malfunction of the flowmeter. Refer to [Problem solving \[► 43\]](#).

Depending on the version, the electrical connection is made using a 1 m long cable or a multi-pin M12 fixed connector which position can be adjusted.

Depending on the version, the device is equipped:

- with one pulse output
- or one pulse output and one 4...20 mA current output.

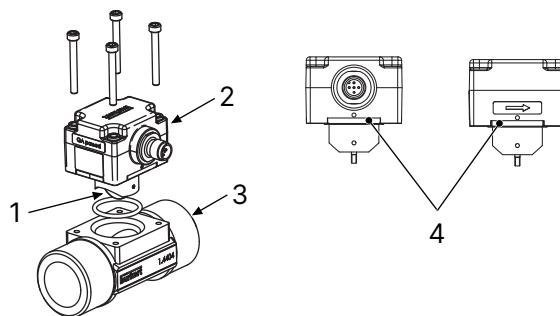

1 Paddle-wheel	2 SE12
3 S012	4 Location of the LEDs

### 3.1.1 Version with pulse output

On the 16 basic versions of the SE12 module (refer to [Article numbers for the basic versions of the SE12 module \[▶ 13\]](#)), the NPN pulse output generates a signal with a frequency  $f$  proportional to the rotation frequency of the paddle-wheel.

To obtain a flow rate  $Q$ , this frequency must be divided by a proportionality factor  $K$  according to the following formula:

$$Q = f/K$$

Characteristic of the pulse output	Possible configurations (on request)	Pulse output of the basic versions
Transistor wiring	<ul style="list-style-type: none"> <li>• NPN</li> <li>• or PNP</li> </ul>	NPN
Behaviour of the output	<ul style="list-style-type: none"> <li>• Frequency proportional to the rotation of the paddle-wheel (see above)</li> <li>• or frequency proportional to a volume (see <a href="#">Frequency proportional to a volume [▶ 36]</a>)</li> <li>• or switching mode (see <a href="#">Switching function [▶ 36]</a>)</li> <li>• or mode detecting the immediate or delayed change of circulation direction of the fluid (only on versions with optical sensor) (see <a href="#">Detection of a change in the fluid direction (only 8012 with optical sensor) [▶ 39]</a>)</li> </ul>	Frequency proportional to the rotation of the paddle-wheel

Tab. 1: Characteristics of the pulse output

### 3.1.2 Version with pulse output and current output

#### Pulse output

The characteristics of the pulse output are identical to those on a version with pulse output only. Refer to [Version with pulse output \[► 10\]](#)

#### Current output

The current output on the basic versions is connected in sink mode and delivers a current I, an image of the rotation frequency f of the paddle-wheel:

$$I = 8f/125 + 4$$

As  $f = KQ$ , the flow Q is therefore proportional to this current:

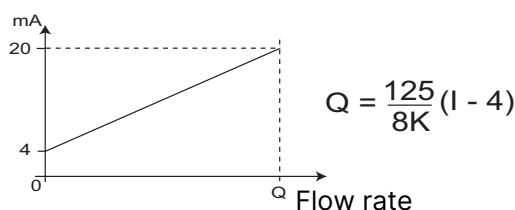

Q	flow rate [litre/s]	K	K factor [pulse/litre]
I	current [mA]		

#### Current attenuation variations

When the flow varies quickly, the current output signal from your device can be stabilised. On the basic versions, the current variations are slightly attenuated.

#### Generation of an alarm current (versions with optical sensor only)

On the basic versions, an "alarm" current of 22 mA is generated when the circulation direction of the fluid is the opposite of the direction of the arrow on the side of the housing.

Characteristic	Possible configurations (on request)	Configuration on a basic version
Wiring	<ul style="list-style-type: none"> <li>• source</li> <li>• or sink</li> </ul>	sink
Current output range and associated measuring range	<ul style="list-style-type: none"> <li>• 4...20 mA, corresponding to the rotation frequency range 0...250 Hz of the paddlewheel (see above)</li> <li>• or 4...20 mA, corresponding to a flow range, in the unit specific to the application (see <a href="#">Extension of the current range [▶ 40]</a>)</li> <li>• or 4...21.6 mA, corresponding to the rotation frequency range 0...275 Hz of the paddlewheel (see <a href="#">Extension of the current range [▶ 40]</a>)</li> <li>• or 4...21.6 mA, corresponding to a flow range, in the unit specific to the application (see <a href="#">Conversion of the frequency into a flow rate [▶ 40]</a>)</li> </ul>	4...20 mA, corresponding to the 0...250 Hz rotation frequency range of the paddlewheel
Current attenuation variations	Ten possible attenuation levels: ranging from "no attenuation" to "maximum attenuation" (see <a href="#">Current attenuation variations [▶ 41]</a> )	Slight attenuation of the current variations

Tab. 2: Current output data

### 3.2 Type label

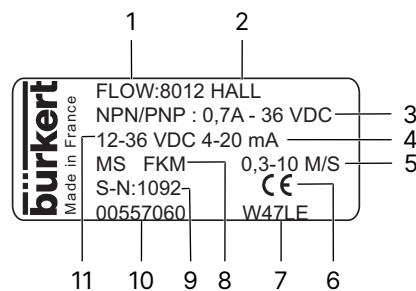

Fig. 1: Description of the type plate of the 8012

1 Measured value and type of the device	2 Type of sensor
3 Characteristics of the pulse output	4 Type of the current output
5 Flow range	6 CE marking
7 Manufacture code	8 Materials the fitting and the seal in contact with the fluid are made of
9 Serial number	10 Article number
11 Supply voltage	

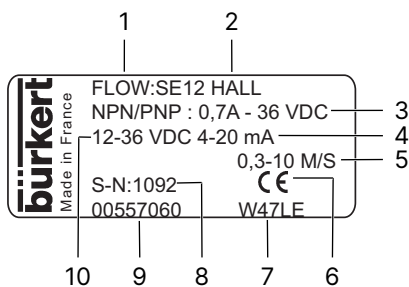

Fig. 2: Description of the type plate of the SE12

1 Measured value and type of the device	2 Type of sensor
3 Characteristics of the pulse output	4 Type of current output
5 Flow range	6 CE marking
7 Manufacture code	8 Serial number
9 Article number	10 Supply voltage

### 3.3 Article numbers for the basic versions of the SE12 module

The fitting S012 is not available as a separate part.

Two versions of the S012 in DN15 and DN20 exist, having different K factors.

Only version 2, identified by the "v2" marking, is available from March 2012. The "v2" marking can be found:

on the bottom of the DN15 or DN20 fitting in plastic:



on the side of the DN15 or DN20 fitting in metal:

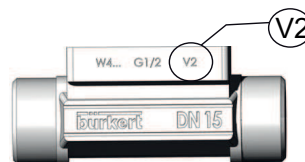

Supply voltage	Measurement principle	Fitting	Electrical connection	Outputs	Article number			
12...36 V DC	Hall	DN6, DN8, DN15 v2 and DN20 v2	Male 5-pin M12 fixed connector	Pulse, NPN	557 054			
				Pulse, NPN + 4...20 mA	557 058			
			Cable gland, including 1 m cable	Pulse, NPN	557 056			
				Pulse, NPN + 4...20 mA	557 060			
		DN15 to DN65 (except DN15 v2 and DN20 v2)	Male 5-pin M12 fixed connector	Pulse, NPN	557 053			
				Pulse, NPN + 4...20 mA	557 057			
			Cable gland, including 1 m cable	Pulse, NPN	557 055			
				Pulse, NPN + 4...20 mA	557 059			
			12...36 V DC	Optical	DN6, DN8, DN15 v2 and DN20 v2	Male 5-pin M12 fixed connector	Pulse, NPN	557 062
							Pulse, NPN + 4...20 mA	557 066
Cable gland, including 1 m cable	Pulse, NPN	557 064						
	Pulse, NPN + 4...20 mA	557 068						
DN15 to DN65 (except DN15 v2 and DN20 v2)	Male 5-pin M12 fixed connector	Pulse, NPN			557 061			
		Pulse, NPN + 4...20 mA			557 065			
	Cable gland, including 1 m cable	Pulse, NPN			557 063			
		Pulse, NPN + 4...20 mA			557 067			

## 4 Technical data

### 4.1 Standards and directives

This product complies with the legal requirements applicable at the time of placing on the market and has been developed and tested in accordance with the relevant European directives/regulations and harmonized standards. The conformity is documented and, if necessary, supported by evidence. The EU Declaration of Conformity can be found behind the respective type on the home page [country.burkert.com](http://country.burkert.com)

### 4.2 Conditions of use

Ambient temperature	-15 to +60 °C
Air humidity	< 80%, non condensated
Protection class acc. to EN 60529	<ul style="list-style-type: none"> <li>• IP67 (version with M12 fixed connector), female connector wired, plugged in and tightened</li> <li>• IP65 (version with cable gland)</li> </ul>
Storage temperature	-15...+60°C

### 4.3 Conformity to standards and directives

The applied standards, which verify conformity with the EU Directives, can be found on the EU Type Examination Certificate and/or the EU Declaration of Conformity (if applicable).

Pressure: according to article 4§1 of the Pressure Equipment Directive 2014/68/EU, the product can only be used in the following cases (depending on the max. pressure, the DN of the pipe and the fluid):

Type of fluid	Conditions
Fluid group 1, Article 4, Paragraph 1.c.i	DN ≤ 25
Fluid group 2, Article 4, Paragraph 1.c.i	DN ≤ 32 or PNxDN ≤ 1000
Fluid group 1, Article 4, Paragraph 1.c.ii	DN ≤ 25 or PNxDN ≤ 2000
Fluid group 2, Article 4, Paragraph 1.c.ii	DN ≤ 200 or PN ≤ 10 bar or PNxDN ≤ 5000

## 4.4 Mechanical data

SE12 electronic housing	PPS
Cable gland, M12 fixed connector	PA
Cable, 1 m	PVC, Tmax = 80 °C
Seal exposed to the fluid	FKM (EDPM on request)
Seal exposed to the ambient air	EDPM
Paddle-wheel holder	PVDF
Paddle-wheel	PVDF
Paddle-wheel axis and bearings	ceramic
Body of the S012 fitting	stainless steel (316L/DIN1.4404), brass, PVC, PP, PVDF
Screws	Stainless steel A4

## 4.5 Dimensions

Refer to the related datasheet at [Type 8012](#)

## 4.6 Fluid data

Type of fluid (optical sensor)	transparent to infrared rays
Max. temperature of the fluid	<ul style="list-style-type: none"> <li>Fitting in stainless steel, brass, PVDF:                             <ul style="list-style-type: none"> <li>– 100 °C if the ambient temperature <math>\leq</math> +45 °C</li> <li>– 90 °C if the ambient temperature is between 45 °C and 60 °C</li> </ul> </li> <li>Fitting in PP: 80 °C</li> <li>Fitting in PVC: 60 °C</li> </ul>
Min. fluid temperature	<ul style="list-style-type: none"> <li>Fitting in stainless steel, brass: –15 °C</li> <li>Fitting in PP or PVC: +5 °C</li> <li>Fitting in PVDF: –15 °C</li> </ul>
Fluid pressure	depends on the fitting material; see figure in <a href="#">Safety instructions</a> [▶ 22]
Fluid viscosity	300 cSt max.
Rate of solid particles	1% max.
Measurement range	0.3 m/s to 10 m/s
Measurement deviation	<ul style="list-style-type: none"> <li>standard K factor                             <ul style="list-style-type: none"> <li>+ 2.5% of the measured value<sup>1)</sup></li> </ul> </li> <li>Teach-In                             <ul style="list-style-type: none"> <li><math>\pm</math> 1% of the measured value<sup>1)</sup></li> </ul> </li> </ul>
Linearity	$\pm$ 0.5 % of the full scale (10 m/s)
Repeatability	$\pm$ 0.4% of the measured value <sup>1)</sup>
Measuring element	magnetic or optical sensor

<sup>1)</sup> Values determined in the following reference conditions:  
 medium = water, water and ambient temperatures 20 °C, min. upstream and downstream distances respected,  
 appropriate pipe dimensions

## 4.7 Electrical data

Power supply	12...36 V DC, filtered and regulated
Current consumption	max. 60 mA (at 12 V DC for the version with current output - no load)
Protection against polarity reversal	yes
Protection against spike voltages	yes
Protection against short circuits	yes, for the pulse output
Pulse output	transistor, NPN by default (can be configured as PNP, on request), open collector, 700 mA max., NPN output: 0.2...36 V DC and PNP output: supply voltage, frequency up to 300 Hz (frequency = K factor x flow rate). Configurable on request
Current output (depending on version)	4...20 mA, sinking wiring by default, equals the rotation frequency of the paddle-wheel (by default). Configurable on request
max. loop impedance	<ul style="list-style-type: none"><li>• 1125 <math>\Omega</math> at 36 V DC</li><li>• 650 <math>\Omega</math> at 24 V DC</li><li>• 140 <math>\Omega</math> at 12 V DC</li></ul>

## 4.8 Electrical connections

With a cable gland	Cable, 1 m
With a fixed connector	5-pin M12 fixed connector, adjustable in position

## 4.9 K factors

The K factors have all been determined in the following reference conditions:

medium = water, water and ambient temperatures 20 °C, min. upstream and downstream distances respected, appropriate pipe dimensions

---

Two versions of the S012 in DN15 and DN20 exist, having different K factors. Only version 2, identified by the "v2" marking, is available from March 2012. The "v2" marking can be found:

---

on the bottom of the DN15 fitting in plastic



on the side of the DN15 or DN20 fitting in metal

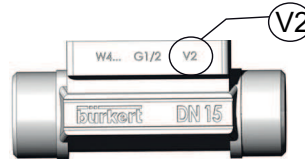

---

The names of the following norms have changed in the Operating Instructions:

- for the welding ends, norm BS 4825 is renamed BS 4825-1
- for the clamp connections, norm BS 4825 is renamed BS 4825-3
- for the clamp connections, norm ISO (for pipes acc. to EN ISO 1127 / ISO 4200) is renamed DIN 32676 series B
- for the clamp connections, norm DIN 32676 is renamed DIN 32676 series A
- for the flange connections, norm EN 1092-1 (ISO PN16) is renamed EN 1092-1 / B1 / PN16

Material	Type of connections and standard	K factor [Pulse/litre] <sup>2)</sup>					
		DN6	DN8	DN15	DN15 v2	DN20	DN20 v2
Stainless steel	welding ends acc. to						
	• SMS 3008	-	-	-	-	97,0	73,4
	• to DIN 11866 series C / BS 4825-1 / ASME BPE	-	-	-	-	97,0	73,4
	• DIN 11866 series B / EN ISO 1127 / ISO 4200	450	288	97,0	73,4	61,5	-
Stainless steel	external threads acc. to						
	• G	450	288	97,0	73,4	61,5	-
Stainless steel	internal threads acc. to						
	• G, Rc, NPT	450	288	97,0	73,4	61,5	-
Stainless steel	clamp acc. to						
	• SMS 3017	-	-	-	-	97,0	73,4
	• BS 4825-3 / ASME BPE	-	-	-	-	97,0	73,4
	• DIN 32676 series A	450	288	97,0	73,4	61,5	-
Stainless steel	flanges acc. to						
	• EN 1092-1 / B1 / PN16	450	288	97,0	73,4	61,5	-
	• ANSI B16-5						
	• JIS 10K						
Brass	all	450	288	97,0	73,4	61,5	-
PVC	all	450	288	110	83,5	76,5	-
PP	all	-	-	115	86,6	77,0	-
PVDF	all	450	288	120	89,6	73,2	-

<sup>2)</sup> K factor in pulse/US gallon = K factor in pulse/l x 3,785  
K factor in pulse/UK gallon = K factor in pulse/l x 4,546

Material	Type of connection and standard	K factor [Pulse/litre] <sup>2)</sup>				
		DN25	DN32	DN40	DN50	DN65
Stainless steel	welding ends acc. to					
	• SMS 3008	61,5	47,5	29,5	18,9	10,5
	• to DIN 11866 series C / BS 4825-1 / ASME BPE	61,5	47,5	29,5	18,9	10,5
	• DIN 11866 series B / EN ISO 1127 / ISO 4200	47,5	29,5	18,9	10,5	-
Stainless steel	external threads acc. to					
	• SMS 1145	61,5	47,5	29,5	18,9	10,5
	• G	47,5	29,5	18,9	10,5	-
	internal threads acc. to					
Stainless steel	clamp acc. to					
	• SMS 3017	61,5	47,5	29,5	18,9	10,5
	• BS 4825-3 / ASME BPE	61,5	47,5	29,5	18,9	10,5
	• DIN 32676 series A	47,5	29,5	18,9	10,5	-
Stainless steel	flanges acc. to					
	• EN 1092-1 / B1 / PN16	47,5	29,5	18,9	10,5	-
	• ANSI B16-5					
	• JIS 10K					
Brass	all	47,5	29,5	18,9	10,5	-
PVC	all	51,5	28,2	17,5	10,2	-
PP	all	52,0	29,2	17,0	10,0	-
PVDF	all	52,5	29,5	18,0	10,3	-

## 5 Installation and wiring

### 5.1 Safety instructions

#### **DANGER!**

Danger due to high pressure in the installation.

- ▶ Stop the circulation of fluid, cut off the pressure and drain the pipe before loosening the process connections.

#### **DANGER!**

Danger due to electrical voltage.

- ▶ Shut down and isolate the electrical power source before carrying out work on the system.
- ▶ Observe all applicable accident protection and safety regulations for electrical equipment.

#### **DANGER!**

Danger due to high temperatures of the fluid.

- ▶ Use safety gloves to handle the device.
- ▶ Stop the circulation of fluid and drain the pipe before loosening the process connections.

#### **DANGER!**

Danger due to the nature of the fluid.

- ▶ Respect the prevailing regulations on accident prevention and safety relating to the use of aggressive fluids.

#### **WARNING!**

Risk of injury due to non-conforming installation.

- ▶ The electrical and fluid installation can only be carried out by qualified and skilled staff with the appropriate tools.
- ▶ Install appropriate safety devices (correctly rated fuse and/or circuit-breaker).

#### **WARNING!**

Risk of injury due to unintentional switch on of power supply or uncontrolled restarting of the installation.

- ▶ Take appropriate measures to avoid unintentional activation of the installation.
- ▶ Guarantee a defined or controlled restarting of the process subsequent to the installation of the device.

#### **WARNING!**

Risk of injury if the fluid pressure/ temperature dependency is not respected.

- ▶ Take the fluid pressure / temperature dependency into account according to the nature of the material of the fitting used (see following figure).

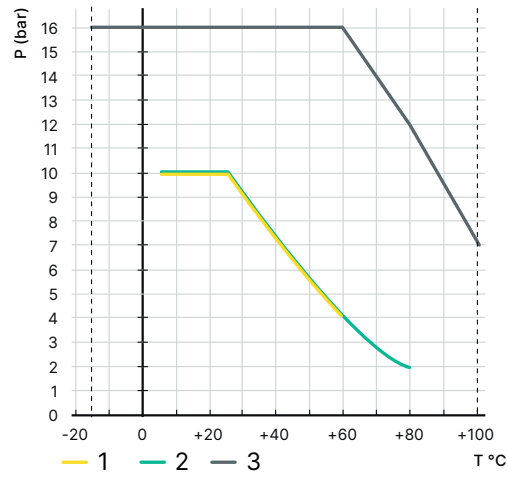

Fig. 3: Fluid pressure /temperature dependency curves

1 PVC	2 PP
3 Metal	

## 5.2 Installation onto the pipe

### **DANGER!**

Danger due to high pressure in the installation.

- ▶ Stop the circulation of fluid, cut off the pressure and drain the pipe before loosening the process connections.

### **DANGER!**

Danger due to high temperatures of the fluid.

- ▶ Use safety gloves to handle the device.
- ▶ Stop the circulation of fluid and drain the pipe before loosening the process connections.

### **DANGER!**

Danger due to the nature of the fluid.

- ▶ Respect the prevailing regulations on accident prevention and safety relating to the use of aggressive fluids.

### 5.2.1 Recommendations for installing the 8012 on the pipe

#### **NOTICE!**

When installing an 8012 with optical sensor:

- ▶ Protect the device from strong light intensity to prevent any disruption of measurements.
- ▶ Ensure that the arrow on the side of the housing is in line with the flow direction of the fluid.

#### **NOTICE!**

Check that the DN of the fitting is dimensioned to the process according to the graphs in [Graphs \[▶ 28\]](#)

- ▶ Install the device on the pipe in such a way that the upstream and downstream distances are respected according to the design of the pipes, as EN ISO 5167-1 standard.

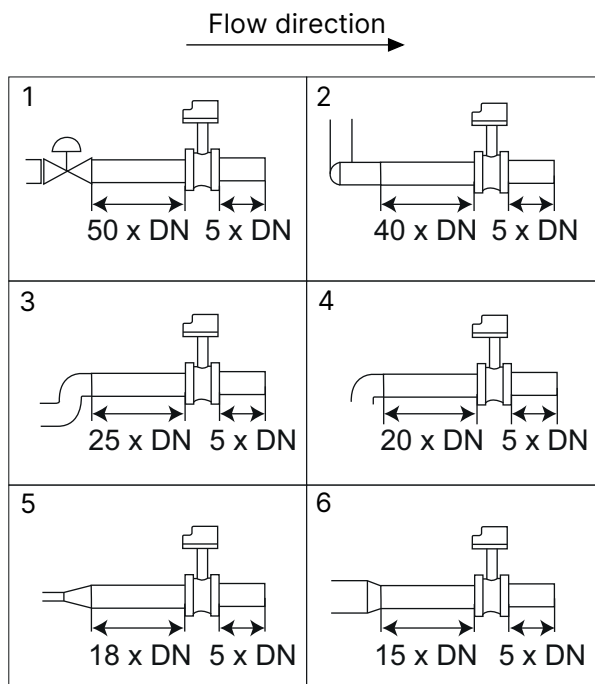

Fig. 4: Upstream and downstream distances depending on the design of the pipes.

1 With regulating valve	2 Pipe with 2 elbows at 90° in 3 dimensions
3 Pipe with 2 elbows at 90°	4 Pipe with 1 elbow at 90° or 1 T-piece
5 With pipe expansion	6 With pipe reduction

- ▶ If necessary, use a flow conditioner to improve measurement precision.
- ▶ Install the device in such a way that the paddle-wheel axis is horizontal.

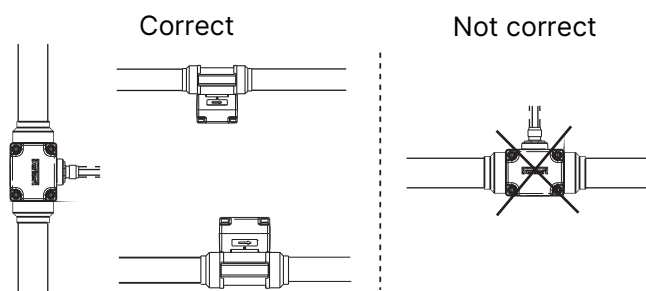

Fig. 5: The paddle-wheel axis must be horizontal

- ▶ Prevent the formation of air bubbles in the pipe in the section around the device.

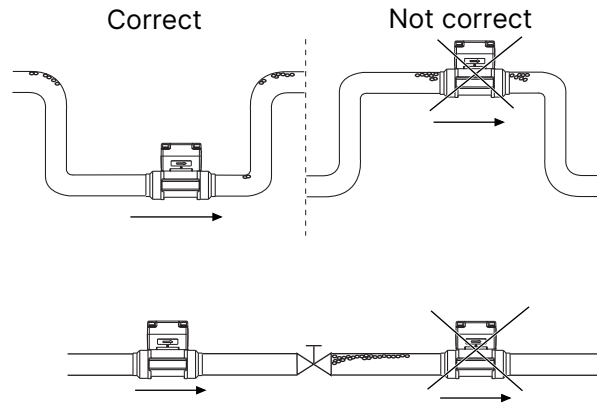

Fig. 6: Air bubbles within the pipe

- ▶ Ensure that the pipe is always filled in the section around the device.

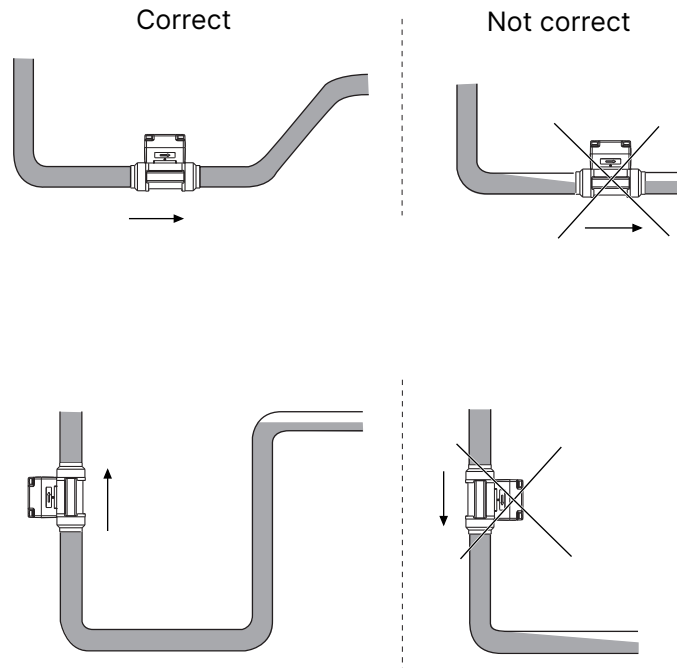

Fig. 7: Filling the pipe

## 5.2.2 Installing a device with welding ends

### NOTICE!

The SE12 electronic module and the seal may be damaged when welding the connections to the pipe.

- ▶ Before welding to the pipe, unscrew the 4 locking screws on the SE12 electronic module.
  - ▶ Remove the electronic module.
  - ▶ Remove the seal.
- 
- ▶ Follow the installation recommendations in [Recommandations for installing the 8012 on the pipe](#) [▶ 24]
  - ▶ Weld the connections.
  - ▶ After welding the connections to the pipe, correctly replace the seal.
  - ▶ Properly replace the electronic module.
  - ▶ Tighten the 4 screws in an alternating pattern, applying a torque of 1.5 Nm.

## 5.2.3 Installing a device with Clamp connections

- ▶ Follow the installation recommendations in [Recommandations for installing the 8012 on the pipe](#) [▶ 24]

### NOTICE!

- ▶ Check that the seals are in good condition.
  - ▶ Place the seals, that have been chosen depending on the process temperature and fluid, into the grooves of the Clamp connections.
- 
- ▶ Fit the Clamp connections to the pipe using a clamping collar.

## 5.2.4 Installing a device with flange connections

- ▶ Follow the installation recommendations in [Recommandations for installing the 8012 on the pipe](#) [▶ 24]

### NOTICE!

- ▶ Check that the seals are in good condition.
  - ▶ Insert a seal, that has been chosen depending on the process temperature and fluid, into the grooves of the connections.
- 

### NOTICE!

- ▶ Make sure the seal remains in its groove when tightening the flange.
- 
- ▶ Tighten the flange to mount the device to the pipe.

### 5.3 Graphs

The graph is used to determine the DN of the pipe and the fitting appropriate to the application, according to the fluid velocity and the flow rate.

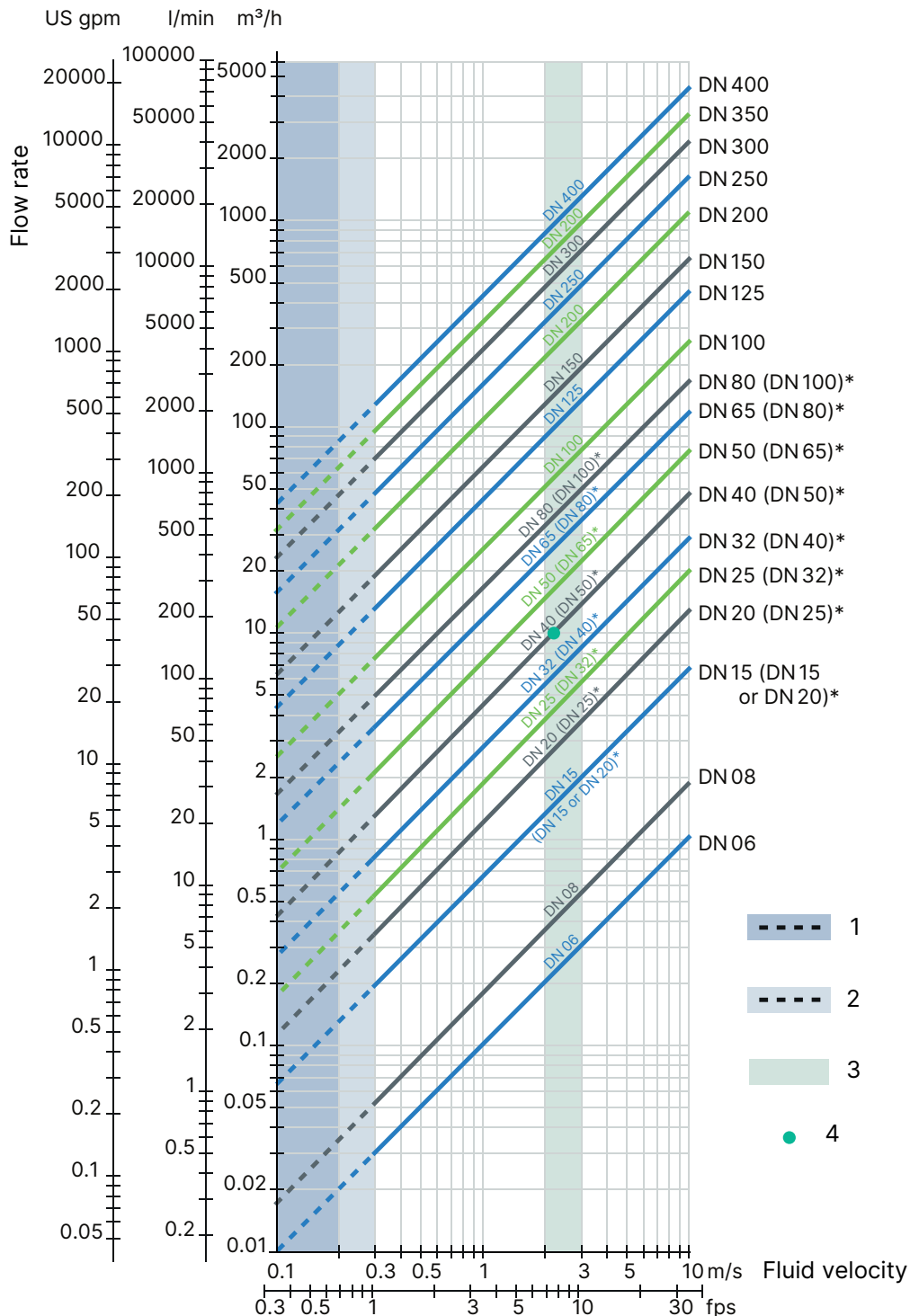

1 Not recommended, if used with Type 8041 or 8045

2 Not recommended, if used with Type 8020, 8025 or 8026

3 Optimal flow rate

4 Diameter of example 1 and example 2

\* Note

- For the fittings listed below, the corresponding nominal size in the bracket must be used:
  - External threads according to SMS 1145
  - Weld ends according to SMS 3008, BS4825-1/ASME BPE/DIN 11866 series C or DIN 11850 series 2/DIN 11866 series A/ DIN EN 10357 series A
  - Clamp according to SMS 3017, BS 4825-3/ASME BPE or DIN 32676 series A
- For all other fittings, the corresponding nominal diameter without bracket applies.

Example 1	Example 2
<ul style="list-style-type: none"><li>• Nominal flow: 10 m<sup>3</sup>/h</li><li>• Optimal flow rate: 2...3 m/s</li></ul> Result: Select a pipe size of DN 40	<p>With external threads according to SMS 1145</p> <ul style="list-style-type: none"><li>• Nominal flow: 10 m<sup>3</sup>/h</li><li>• Optimal flow rate: 2...3 m/s</li></ul> Result: Select a pipe size of DN 50

## 5.4 Electrical wiring



### DANGER!

Risk of injury due to electrical discharge

- ▶ Shut down and isolate the electrical power source before carrying out work on the system.
- ▶ Observe all applicable accident protection and safety regulations for electrical equipment.



Use cables with an operating temperature limit suitable for your application.

### NOTICE!

Use a high quality electrical power supply (filtered and regulated).

- ▶ Under normal conditions of use, cable with a cross section of 0.75 mm<sup>2</sup> should be enough to transmit the signal.
- ▶ Do not install the cable near high voltage or high frequency cables.
- ▶ If this is unavoidable, keep a minimum distance of 30 cm.

### NOTICE!

Make sure the installation is equipotential (power supply - 8012):

- ▶ Connect the different earth connections of the installation to one another in order to remove any differences in potential which may arise between two earth connections.
- ▶ Correctly connect the cable shielding to the earth.
- ▶ Connect the negative power supply terminal to the earth to eradicate the effects of common mode currents. If this connection cannot be made directly, a 100 nF / 50 V capacitor can be fitted between the negative power supply terminal and the earth.

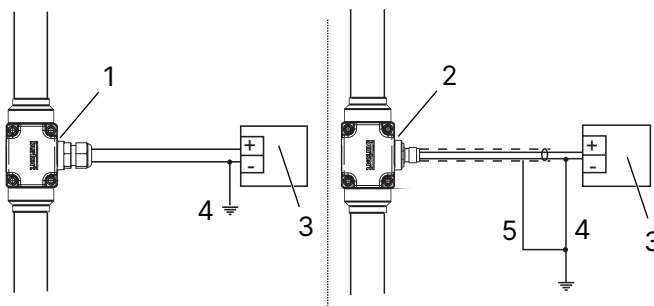

1 8012 with cable gland

2 8012 with M12 fixed connector

3 Power supply 12-36 V DC

4 If a direct earth connection is not possible, fit a 100 nF / 50 V condenser between the negative power supply terminal and the earth

5 If the cable used is shielded.

### 5.4.1 Assembling the M12 female connector

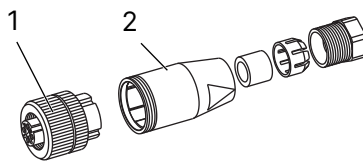

Fig. 8: M12 multi-pin connector (not supplied, ordering code 917116)

1 Nut

2 Connector

- ▶ Completely unscrew the nut.
- ▶ Remove the rear section of the connector.
- ▶ Wire the device. See [Detection of a change in the fluid direction \(only 8012 with optical sensor\)](#) [▶ 39]

## 5.4.2 Wiring a version with adjustable M12 fixed connector

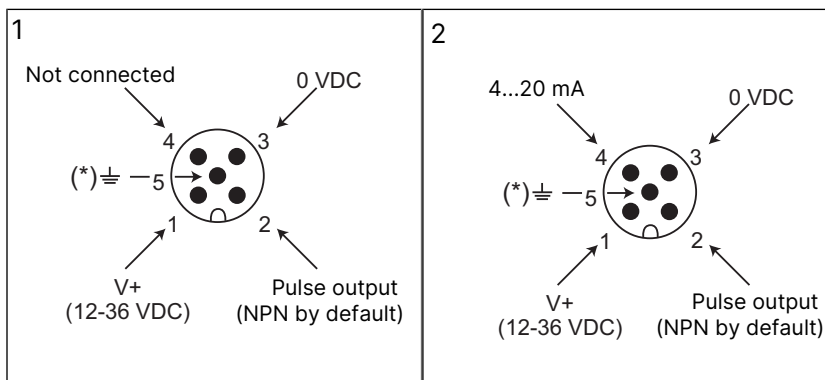

Fig. 9: Pin assignment of the M12 male fixed connector

1 Version with pulse output

2 Version with pulse and current output

(\*) Functional earth; If a direct earth connection is not possible, fit a 100 nF / 50 V capacitor between the negative power supply terminal and the earth.

Pin of the M12 female cable available as accessory equipment (order code 438680)	Colour of the wire
1	brown
2	white
3	blue
4	black
5	grey

The M12 fixed connector of the device is adjustable in position:

- ▶ Unscrew the locknut.
- ▶ Turn the fixed connector to the desired position, by 360° max. so as not to twist the cables inside the enclosure.
- ▶ Tighten the locknut using a spanner, while keeping the fixed connector in the desired position.

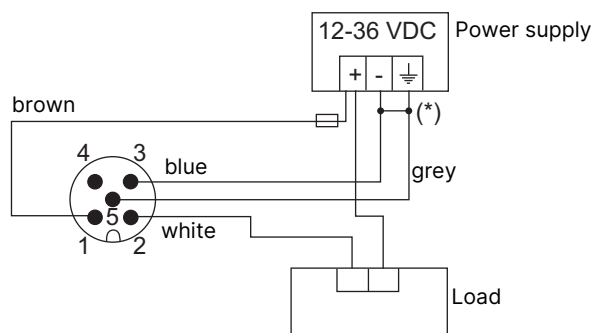

Fig. 10: NPN wiring (default) of the pulse output of a version with M12 fixed connector

(\*) Functional earth; If a direct earth connection is not possible, fit a 100 nF / 50 V capacitor between the negative power supply terminal and the earth.

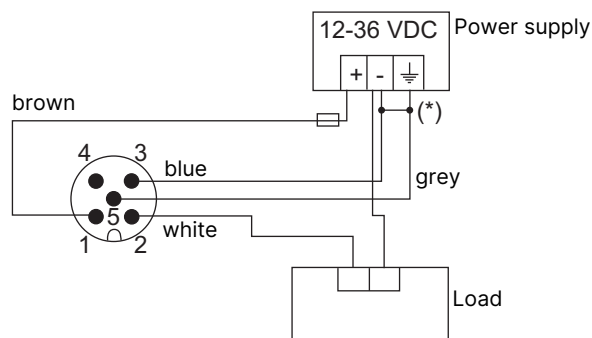

Fig. 11: PNP wiring of the pulse output of a version with M12 fixed connector

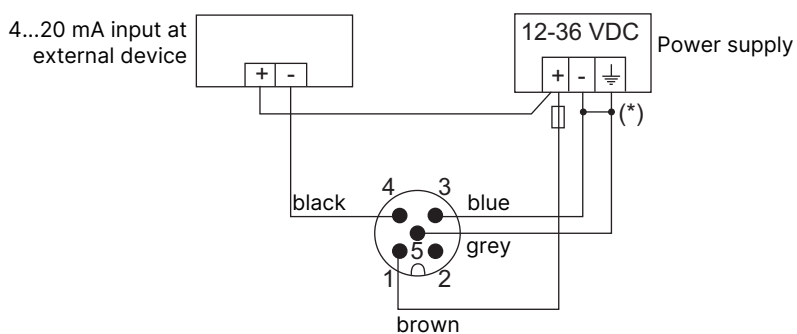

Fig. 12: Wiring the current output in sinking mode (by default) on a version with M12 fixed connector.

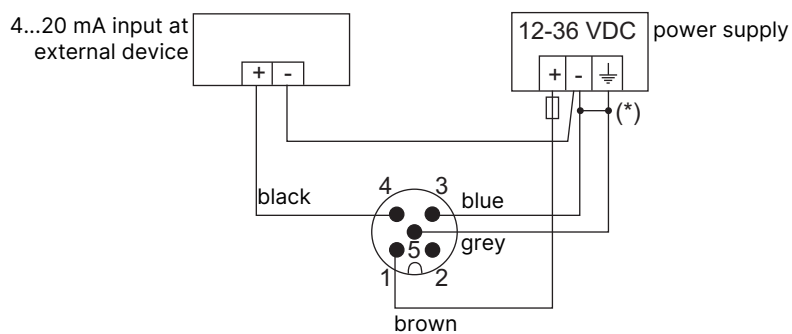

Fig. 13: Wiring the current output in sinking mode (by default) on a version with M12 fixed connector.

(\*) Functional earth; If a direct earth connection is not possible, fit a 100 nF / 50 V capacitor between the negative power supply terminal and the earth.

### 5.4.3 Wiring a version with cable gland

Colour of the wire	BN (brown)	WH (white)	GN (green)	YE (yellow)	GY (grey)
Signal on a version with pulse output	V+ (12...36 V DC)	0 V DC	Functional earth	Not connected	NPN or PNP
Signal on a version with pulse and current outputs	V+ (12...36 V DC)	0 V DC	Functional earth	Current in mA	NPN or PNP

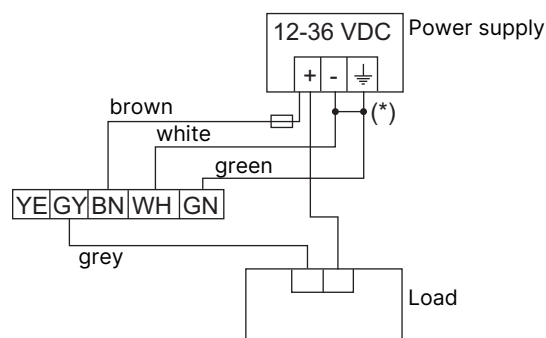

Fig. 14: NPN wiring (default) of the pulse output of a version with cable gland

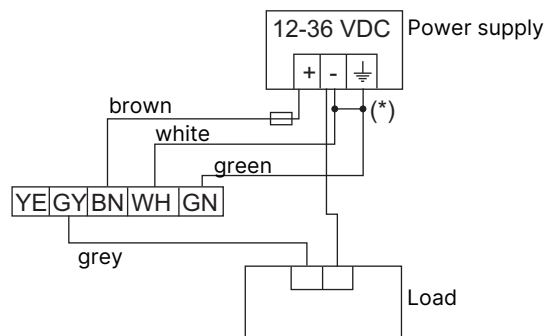

Fig. 15: PNP wiring of the pulse output of a version with cable gland

(\* Functional earth; If a direct earth connection is not possible, fit a 100 nF / 50 V capacitor between the negative power supply terminal and the earth.

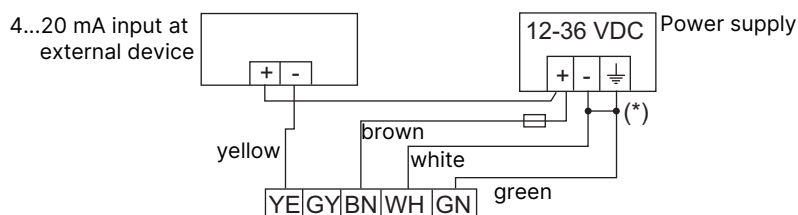

Fig. 16: Wiring the current output in sinking mode (by default) on a version with cable gland

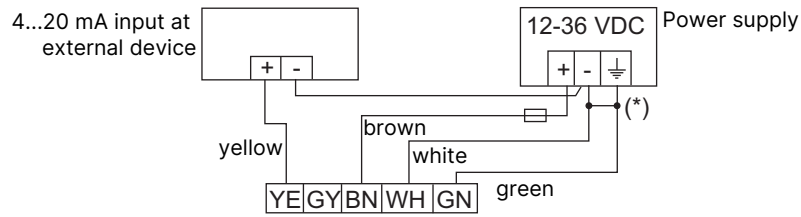

Fig. 17: Wiring the current output in sourcing mode on a version with cable gland

(\*) Functional earth; If a direct earth connection is not possible, fit a 100 nF / 50 V capacitor between the negative power supply terminal and the earth.

## 6 Commissioning

### 6.1 Safety instructions



#### **DANGER!**

Danger due to nonconforming commissioning.

Non conforming commissioning may lead to injuries and damage the device and its surroundings.

- ▶ Before commissioning, make sure that the staff in charge have read and fully understood the contents of the Operating Instructions.
- ▶ In particular, observe the safety recommendations and intended use.
- ▶ The device / the installation must only be commissioned by suitably trained staff.

#### **NOTICE!**

Risk of damage to the device due to the environment

- ▶ Protect this device against electromagnetic interference, ultraviolet rays and, when installed outdoors, the effects of the climatic conditions.

## 7 Adjustment and functions

### 7.1 Safety instructions



#### **DANGER!**

Risk of injury due to non-conforming adjustment.

Non-conforming adjustment could lead to injuries and damage the device and its surroundings.

- ▶ The operators in charge of adjustment must have read and understood the contents of these Operating Instructions.
- ▶ In particular, observe the safety recommendations and intended use.
- ▶ The device/installation must only be adjusted by suitably trained staff.

### 7.2 Pulse output

The pulse output of the device can be parametered with one of the following functions.

#### 7.2.1 Frequency proportional to a volume

This function is used to generate a pulse each time a predetermined volume of fluid passed.

#### 7.2.2 Switching function

The pulse output of the 8012 can be parametered to switch a solenoid valve or activate an alarm.

The following parameters can be preset:

- hysteresis or window operating, inverted or not
- the switching thresholds, low and high
- immediate or delayed switching

### Hysteresis operating

The output status changes when a threshold is reached:

- by increasing flow rate, the output status changes when the high threshold is reached.
- by decreasing flow rate, the output status changes when the low threshold is reached.

The behaviour of the output depends on the output wiring, NPN or PNP.

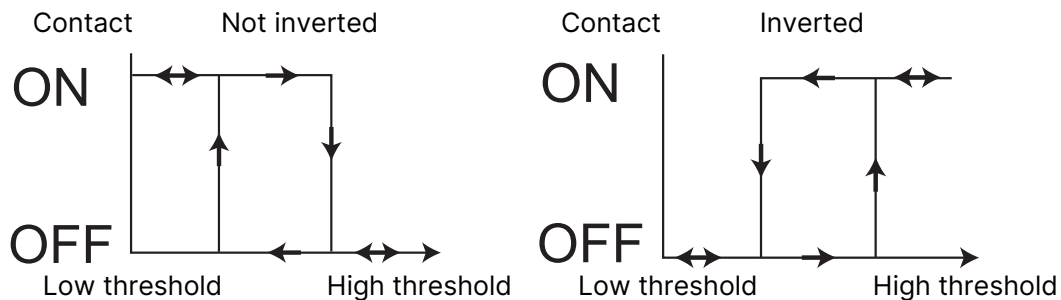

Fig. 18: NPN pulse output, hysteresis operating, non inverted and inverted

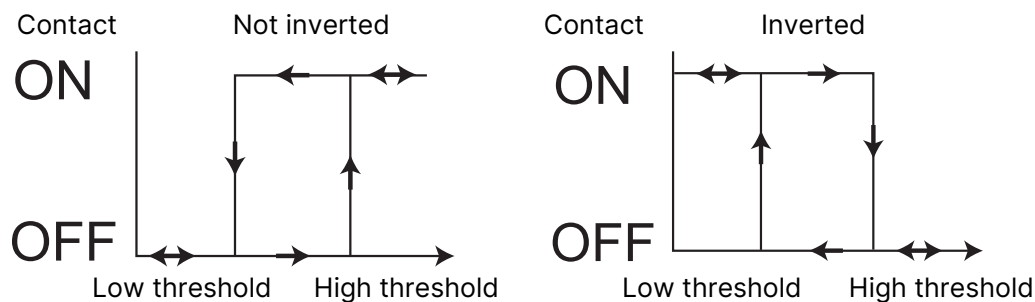

Fig. 19: PNP pulse output, hysteresis operating, non inverted and inverted

### Window operating

The output status changes when either threshold is reached. The behaviour of the output depends on the output wiring, NPN or PNP.

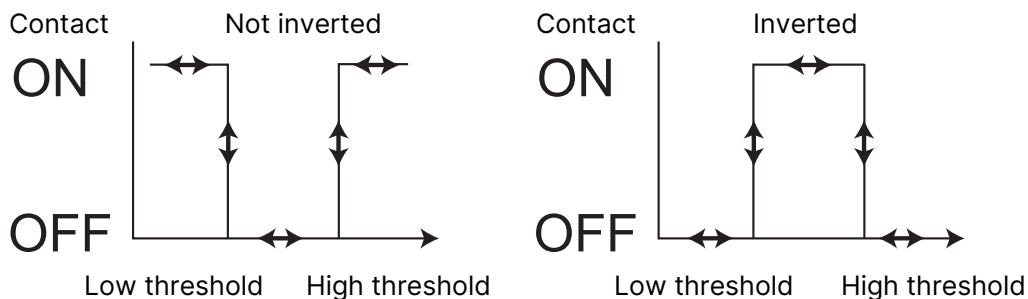

Fig. 20: NPN pulse output, window operating, non inverted and inverted

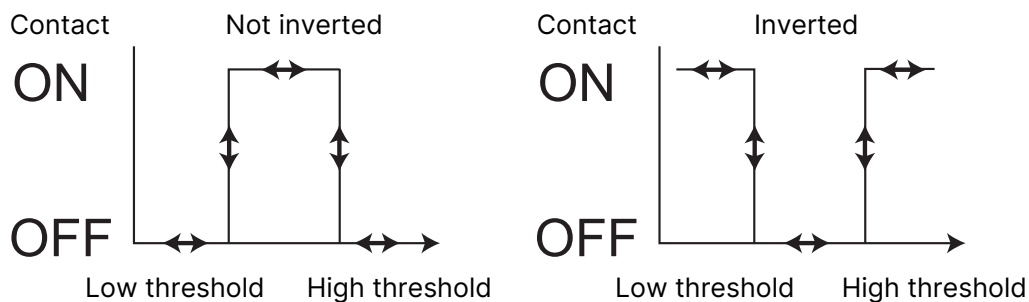
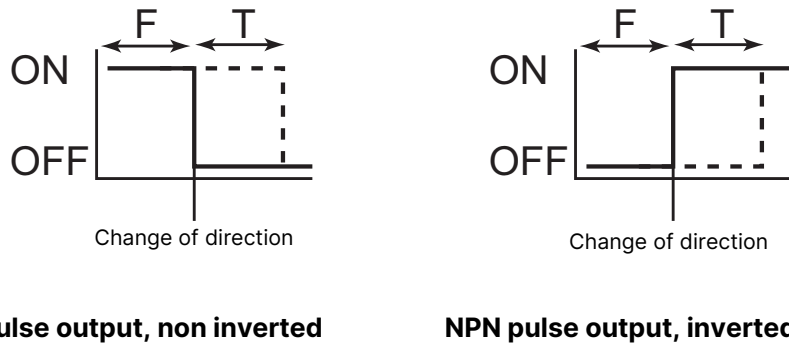

Fig. 21: PNP pulse output, window operating, non inverted and inverted

### 7.2.3 Detection of a change in the fluid direction (only 8012 with optical sensor)

On an 8012 with optical sensor, the pulse output can be configured to indicate a change in the fluid circulation direction. Furthermore the change of direction can be indicated immediately or after a configurable time delay.

The behaviour of the output depends on the output wiring, NPN or PNP, and on the operating, inverted or not.



F = Fluid direction same as direction of the arrow on the housing  
T = Time delay before switching

Fig. 22: Detection of the change in fluid circulation direction; NPN pulse output, not inverted and inverted

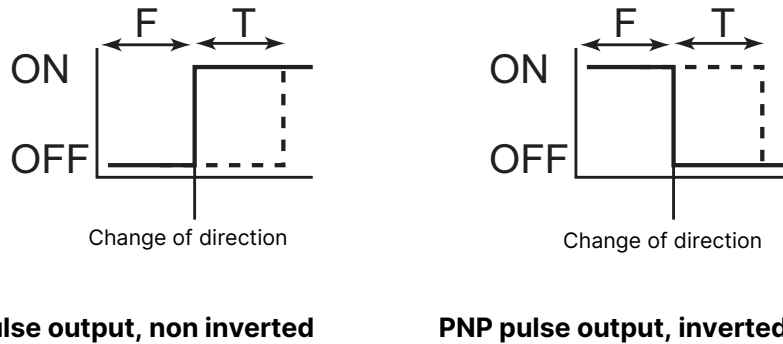

F = Fluid direction same as direction of the arrow on the housing  
T = Time delay before switching

Fig. 23: Detection of the change in fluid circulation direction; PNP pulse output, not inverted and inverted

#### Time delay before switching

Switching occurs if one of the thresholds (low, high) is exceeded for a duration higher than the parametered time delay. The time delay is applied to both switching thresholds. If the time delay equals 0, switching occurs immediately.

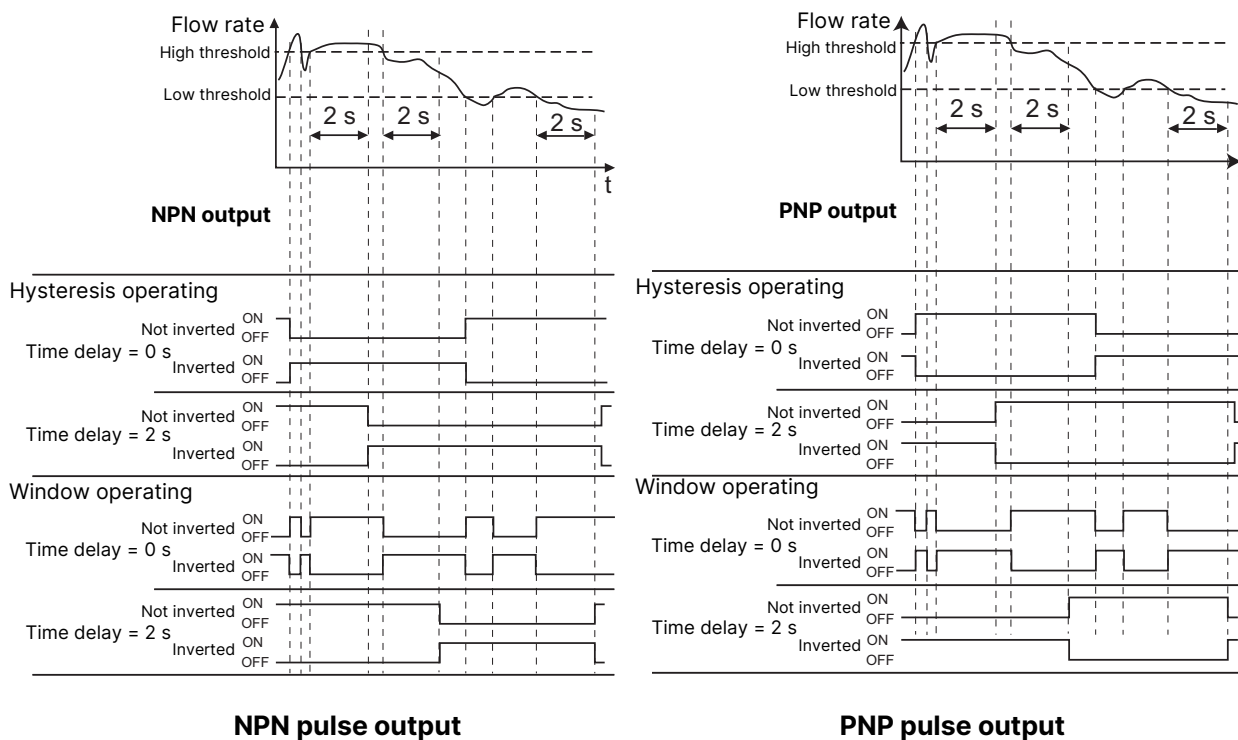

Fig. 24: Examples of behaviour of the 8012 depending on the flow rate in the pipe and the switching operating chosen for the pulse output

## 7.3 Current output

The current output, if one exists, can be parametered with the following functions:

- an extended output range or the current output range corresponding to a flow range
- an attenuation of the current variations, different from that of the basic versions.

### 7.3.1 Extension of the current range

The current output of the device can be configured to deliver a current varying from 4 to 21.6 mA, depending on the paddle-wheel rotation frequency.

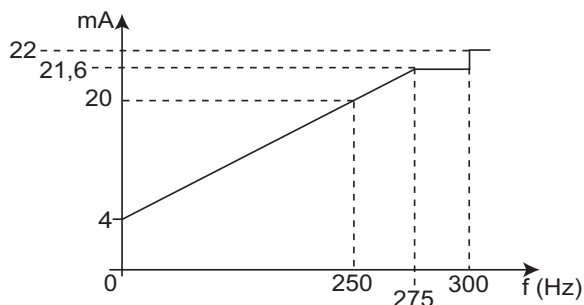

Fig. 25: Curve for the current proportional to the paddle-wheel rotation frequency

### 7.3.2 Conversion of the frequency into a flow rate

The 8012 can be parametered to convert the paddle-wheel rotation frequency into a flow rate, in a unit specific to the application.

In this case, the 8012 is parametered with the K factor of the device and the desired flow rate unit.

The following flow units are available:

l/s, l/min., l/h, m<sup>3</sup>/min., m<sup>3</sup>/h, Ga/s, Ga/min., Ga/h, USGa/s, USGa/min., USGa/h.

The current output then delivers a current of 4 to 20 mA or 4 to 21.6 mA proportional to a flow rate range:

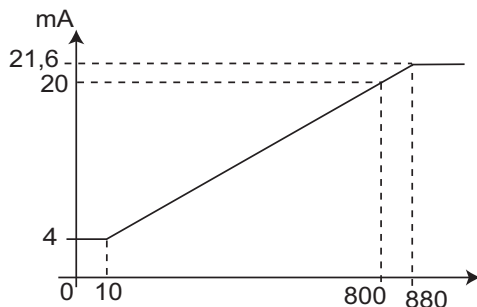

Fig. 26: Curve for the current proportional to the flow rate

### 7.3.3 Current attenuation variations

When the flow varies quickly, the current output signal from your device can be stabilised.

The device can be configured with one of the 10 filter levels available, varying from no filter to maximum filter.

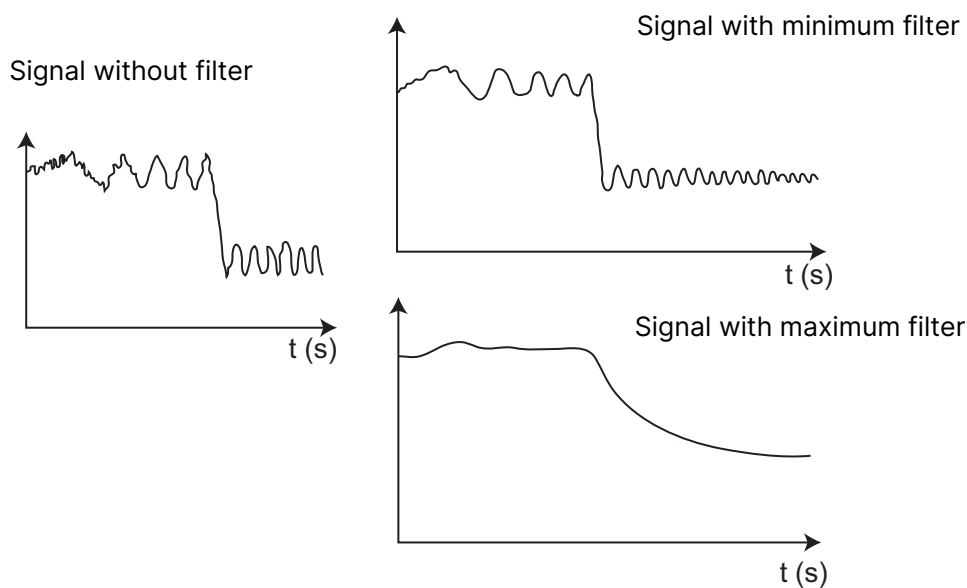

Fig. 27: Different filter levels for current fluctuations

## 8 Maintenance and troubleshooting

### 8.1 Safety instructions

#### **DANGER!**

Risk of injury due to high pressure in the installation.

- ▶ Stop the circulation of fluid, cut off the pressure and drain the pipe before loosening the process connections.

#### **DANGER!**

Risk of injury due to electrical voltage.

- ▶ Shut down and isolate the electrical power source before carrying out work on the system.
- ▶ Observe all applicable accident protection and safety regulations for electrical equipment.

#### **DANGER!**

Risk of injury due to high fluid temperatures.

- ▶ Use safety gloves to handle the device.
- ▶ Stop the circulation of fluid and drain the pipe before loosening the process connections.

#### **DANGER!**

Risk of injury due to the nature of the fluid.

- ▶ Respect the prevailing regulations on accident prevention and safety relating to the use of aggressive fluids.

#### **WARNING!**

Risk of injury due to non-conforming maintenance.

- ▶ Maintenance must only be carried out by qualified and skilled staff with the appropriate tools.
- ▶ Ensure that the restart of the installation is controlled after any interventions.

### 8.2 Cleaning

Depending on the nature of the fluid, regularly check for clogging of the paddle-wheel.

#### **NOTICE!**

The device may be damaged by the cleaning liquid.

- ▶ Clean the device with a cloth slightly dampened with water or a cleaning liquid compatible with the materials the device is made of.

## 8.3 Replacing the seal

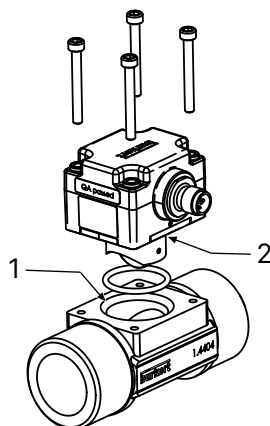

Fig. 28: Exploded view of the 8012

1 O-ring for plastic fitting

2 O-ring for metal fitting

- ▶ Unscrew the 4 screws in the electronic module and remove it from the fitting.
- ▶ Remove the used seal.
- ▶ Clean the surfaces on which the seal is placed.
- ▶ Insert the new seal.
- ▶ Position the electronic module on the fitting so that the arrow points in the fluid direction on versions with optical sensor.
- ▶ Insert the 4 screws into the electronic module (use the long screws for a plastic S012, DN6 or DN8 fitting).
- ▶ Tighten the 4 screws in an alternating pattern, to a torque of 1.5 Nm.

## 8.4 Problem solving



### **DANGER!**

Risk of injury due to high pressure in the installation.

- ▶ Stop the circulation of fluid, cut off the pressure and drain the pipe before loosening the process connections.



### **DANGER!**

Risk of injury due to electrical voltage.

- ▶ Shut down and isolate the electrical power source before carrying out work on the system.
- ▶ Observe all applicable accident protection and safety regulations for electrical equipment.



### **DANGER!**

Risk of injury due to high fluid temperatures.

- ▶ Use safety gloves to handle the device.
- ▶ Stop the circulation of fluid and drain the pipe before loosening the process connections.

**! DANGER!**

Risk of injury due to the nature of the fluid.

- ▶ Respect the prevailing regulations on accident prevention and safety relating to the use of aggressive fluids.

**Problems signalled by the LEDs**

Status red LED	Status green LED	Status current output	Possible cause	Recommended action
Flashes 3 times every second	Off	22 mA	Full scale exceeded (flow rate in the pipe is too high)	Check the process parameters
On	Off	22 mA	Memory problem	Switch the power supply off then on. If the error persists, contact your Bürkert retailer.
Off	Flashes twice every second	22 mA	The device with optical detection is mounted in the wrong direction	Mount the device, ensuring that the arrow on the side of the housing indicates the direction of the fluid.

**Problems not signalled by the LEDs**

Problem	Recommended action	See chapter
The device does not function	<ul style="list-style-type: none"> <li>▶ Check the wiring</li> <li>▶ Check that the device is energized</li> </ul>	<a href="#">Electrical wiring [▶ 29]</a>
The pulse output does not work	▶ Check whether the wiring is suitable for the output type, NPN or PNP	<a href="#">Electrical wiring [▶ 29]</a>
The current output does not work	▶ Check whether the wiring is suitable for the output type, source or sink	<a href="#">Electrical wiring [▶ 29]</a>
The flow rate measurement is incorrect	▶ Recalculate and change the setting of the K factor	<a href="#">K factors [▶ 19]</a>

## 9 Spare parts and accessories

### CAUTION!

Risk of injury and/or damage caused by the use of unsuitable parts.

Incorrect accessories and unsuitable spare parts may cause injuries and damage the device and the surrounding area.

- ▶ Use only original accessories and original spare parts from Bürkert.

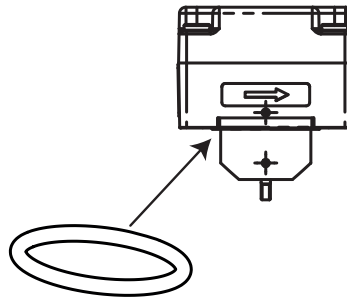

Fig. 29: Seal for metal fitting

Spare part	Article number
Seal for metal fitting	
FKM (DN6 to DN65)	426 340
EPDM (DN6 to DN65)	426 341

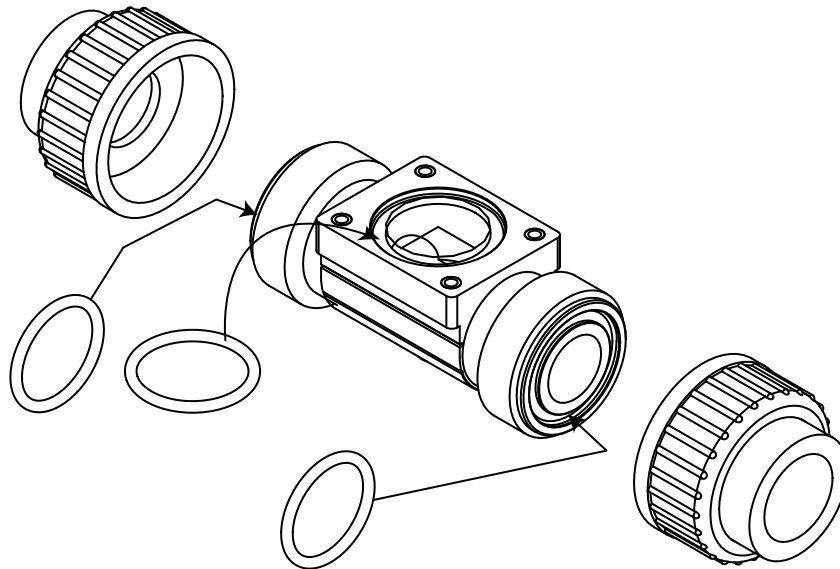

Fig. 30: Seals for plastic fitting

**Type 8012**

Spare parts and accessories

Spare part	Article number
Set of 2 O-rings for the end pieces (true union connections only) + 1 flat seal and 1 O-ring for the SE12 electronic module connection	
The O-ring is only intended for fitting body with flat bottom groove. The O-ring is not suitable for fitting body with ribbed groove (old variant).	
FKM - DN8	448 679
FKM - DN15	431 555
FKM - DN20	431 556
FKM - DN25	431 557
FKM - DN32	431 558
FKM - DN40	431 559
FKM - DN50	431 560
EPDM - DN8	448 680
EPDM - DN15	431 561
EPDM - DN20	431 562
EPDM - DN25	431 563
EPDM - DN32	431 564
EPDM - DN40	431 565
EPDM - DN50	431 566
Set of screws: 4 short screws (M4x35 - A4) + 4 long screws (M4x60 - A4)	555 775
Accessory	Article number
5-pin M12 female connector, moulded on shielded cable (2 m)	438 680
5-pin M12 female connector, to be wired	917 116
Set including:	556 500
<ul style="list-style-type: none"> <li>• 1 CD with TACT (TrAnsmmitter Configuration Tool) configuration software</li> <li>• 1 TACT interface board</li> <li>• 2 connection cables</li> </ul>	
Set of connection cables for the TACT interface	556 160

## 10 Logistics

### 10.1 Transport and storage

- ▶ Protect the device against moisture and dirt in the original packaging during transportation and storage.
- ▶ Avoid UV radiation and direct sunlight.
- ▶ Protect connections, if present, from damage with protective caps.
- ▶ Observe the permitted storage temperature.

### 10.2 Return



---

No work or tests will be carried out on the device until a valid Contamination Declaration has been received.

---

- ▶ To return a used device to Bürkert, contact the Bürkert sales office. A return number is required.

### 10.3 Disposal

Environmentally friendly disposal



- ▶ Follow national regulations regarding disposal and the environment.
- ▶ Collect electrical and electronic devices separately and dispose of them as special waste.

Further information at [country.burkert.com](https://country.burkert.com)