

Type 6020

2-way proportional valve, direct-acting

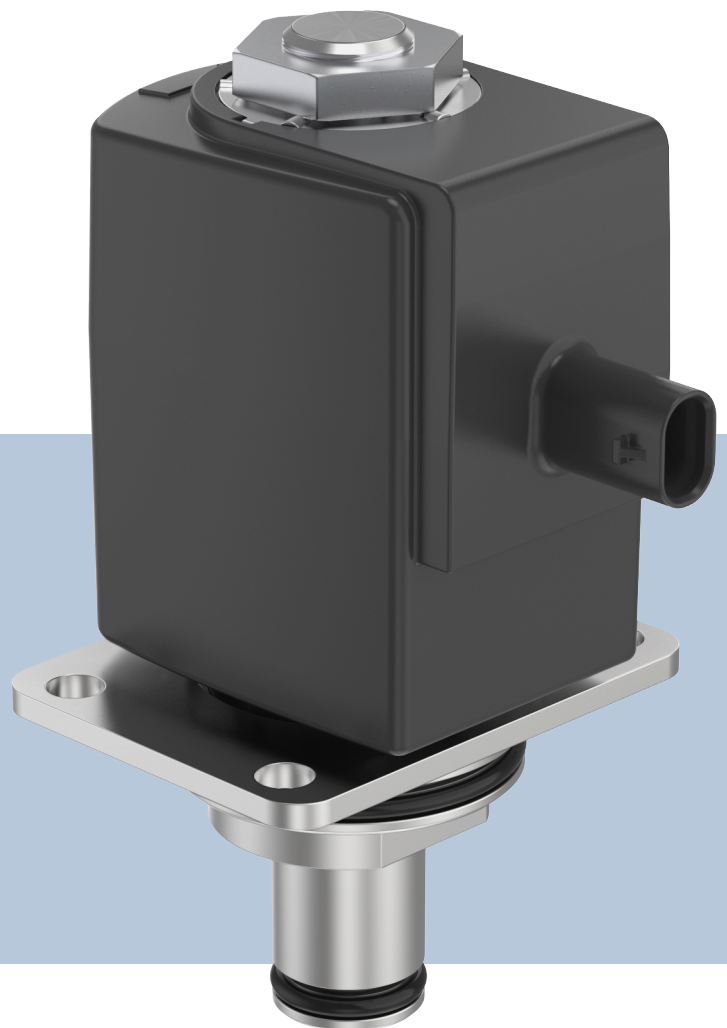

Operating Instructions

We reserve the right to make technical changes without notice.

© Bürkert Werke GmbH & Co. KG 2023-2026

Technical documentation 2601/04_GBen_00815430_682245387_54043196210702091 / Original DE

Contents

1	About this document	4
1.1	Manufacturer	4
1.2	Symbols	4
1.3	Terms and abbreviations	6
2	Safety	7
2.1	Intended use	7
2.2	Safety instructions	7
3	Product description	10
3.1	Product structure	10
3.2	Product identification	11
3.2.1	Type label	11
4	Technical data	12
4.1	Standards and directives	12
4.2	Instructions for operating proportional valves	12
4.3	Operating conditions	13
4.4	Circuit function	15
5	Installation	16
5.1	Preparatory work	16
5.2	Cable plug installation	16
5.3	Installation of socket variants	17
5.4	Cartridge variant installation	17
5.5	Flange variant installation	20
5.6	Coil installation	22
6	Electrical connection	24
6.1	Cable plug Type 2518, plug shape A according to DIN EN 175301-803	24
6.2	Automotive connectors for IP6K9K coil variants side by side	25
7	Faults	26
8	Logistics	27
8.1	Transport and storage	27
8.2	Disposal	27

1 About this document

The document is an important part of the product and guides the user to safe installation and operation. The information and instructions in this document are binding for the use of the product.

- ▶ Before using the product for the first time, read and observe the whole safety chapter.
- ▶ Before starting any work on the product, read and observe the respective sections of the document.
- ▶ Keep the document available for reference and give it to the next user.
- ▶ Contact the Bürkert sales office for any questions.



Further information concerning the product at [Products](#).

- ▶ Enter the article number from the type label in the search bar.

The illustrations in these instructions may vary depending on the product variant.

1.1 Manufacturer

Bürkert Fluid Control Systems
Christian-Bürkert-Str. 13-17
74653 Ingelfingen
GERMANY

The contact addresses are available at [Contact](#).



Need more information or additional products?

- ▶ Explore the full range of products on our [eShop](#).

1.2 Symbols



DANGER!

Warns of a danger that leads to death or serious injuries.



WARNING!

Warns of a danger that can lead to death or serious injuries.



CAUTION!

Warns of a danger that can lead to minor injuries.

NOTICE!

Warns of property damage on the product or the installation.



Indicates important additional information, tips and recommendations.



Refers to information in this document or in other documents.

Type 6020

About this document

► Indicates a step to be carried out.

✓ Indicates a result.

Menu Indicates a software user-interface text.

1.3 Terms and abbreviations

The terms and abbreviations are used in this document to refer to following definitions.

Device	Type 6020 2-way proportional valve
bar	Unit for relative pressure

2 Safety

2.1 Intended use

The direct-acting proportional valve is designed as a control valve for process control.

Prerequisites for safe and trouble-free operation are proper transport, storage, installation, commissioning, operation and maintenance.

The instructions are part of the device. The device is intended exclusively for use within the scope of these instructions. Uses of the device that are not described in these instructions, the contractual documents or the type label can lead to severe personal injury or death, damage to the device or property and dangers for the surrounding area or the environment.

- ▶ Do not mechanically load the device.
- ▶ Do not use the device in potentially explosive atmosphere.
- ▶ Do not use the device outdoors.
- ▶ Only trained and qualified personnel may install, operate and maintain the device. See qualification of persons in [Safety instructions](#) [▶ 7]
- ▶ Use the device only in conjunction with third-party devices and components recommended and authorized by Bürkert.
- ▶ Use the device only when it is in perfect condition.

2.2 Safety instructions

Qualification of personnel working with the device

Improper use of the device can lead to serious personal injury or death. To avoid accidents when working with the device, the following minimum requirements must be met:

- ▶ Carry out work on the device within the scope of these instructions in a safety-compliant manner.
- ▶ Detect and avoid dangers when working on the device.
- ▶ Understand the instructions and implement the information contained therein accordingly.

Responsibility of the operator

The operator is responsible for observing the location-specific safety regulations, also in relation to personnel.

- ▶ Observe the general rules of technology.
- ▶ Install the device according to the regulations applicable in the respective country.
- ▶ The operator must make hazards arising from the location of the device avoidable by providing appropriate operating instructions.

Changes and other modifications, spare parts and accessories

Changes to the device, incorrect installation or use of non-approved devices or components create hazards that can lead to accidents and injuries.

- ▶ Do not make any changes to the device.
- ▶ Do not mechanically load the device.

- ▶ Observe the operating instructions of the device or component used.
- ▶ Only use the devices in conjunction with devices and components recommended or approved by Bürkert.

Spare parts and accessories that do not meet Bürkert's requirements may impair the operational safety of the device and cause accidents.

- ▶ To ensure operational safety, only use original parts from Bürkert.

Operation only after proper transport, storage, installation, commissioning, or maintenance

Improper transport, storage, installation, commissioning, or maintenance jeopardises the operational safety of the device and can cause accidents. This can lead to serious personal injury or death.

- ▶ Observe all values and limits specified in these instructions to ensure the device's safety and functionality.
- ▶ Only carry out work described in these instructions.
- ▶ Only carry out work using suitable tools.
- ▶ All other work must be carried out by Bürkert only.

Technical limit values and media

Non-compliance with technical limit values or unsuitable media can damage the device and lead to leaks. This can cause accidents and seriously injure or kill people.

- ▶ Comply with limit values. See **Technical data** [▶ 12] and information on the type label.
- ▶ Only feed media into the media ports that are listed in the chapter **Technical data** [▶ 12].
- ▶ Observe the safety data sheet for the media used.

Medium under pressure

Medium under pressure can seriously injure people. In the event of overpressure or pressure surges, the device or lines can burst. Pneumatic lines that are defective or not securely fastened can come loose and swing around.

- ▶ Before working on the device or system, switch off the pressure. Vent or empty the lines.
- ▶ Adhere to the permitted pressure ranges of the medium.
- ▶ Comply with the permitted temperature ranges of the medium.

Electric shock due to electrical components

Touching live parts can result in severe electric shock. This can lead to serious personal injury or death.

- ▶ Before working on the device or system, switch off the power supply. Secure it against reactivation.
- ▶ Observe any applicable accident prevention and safety regulations for electrical devices.

Hot surfaces and fire hazard

The surface of the device can become hot with fast-switching actuators or with hot media.

- ▶ Wear suitable protective gloves.
- ▶ Keep highly flammable substances and media away from the device.

Working on the device

Working on the device that has not been powered down, unauthorised switching on or uncontrolled start-up of the system can cause accidents. This can lead to serious personal injury or death.

- ▶ Only work on the device when it is not in use.
- ▶ Ensure that the device or system cannot be switched on unintentionally.
- ▶ Only start the process in a controlled manner following disruptions. Observe sequence:
 1. Apply supply voltage or pneumatic supply.
 2. Charge the device with medium.

3 Product description

Type 6020 is a direct-acting 2/2-way proportional valve with the following properties:

- Proportional valve for flow or pressure control and fuel cell systems and other hydrogen applications
- Integrated shut-off function with reliably high tightness
- Excellent responding behaviour and high setting range
- Available as flange or cartridge variant for quick system integration
- Degree of protection IP65 or IP6K9K with automotive plug

3.1 Product structure

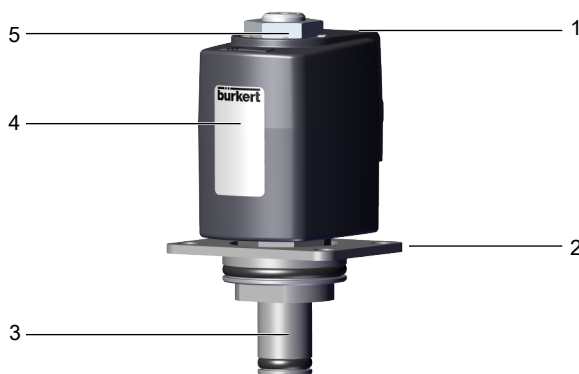

Fig. 1: Type 6020 cartridge variant (example: FC17)

1 Coil	2 Retaining plate
3 Valve body	4 Type label
5 Nut for coil attachment	

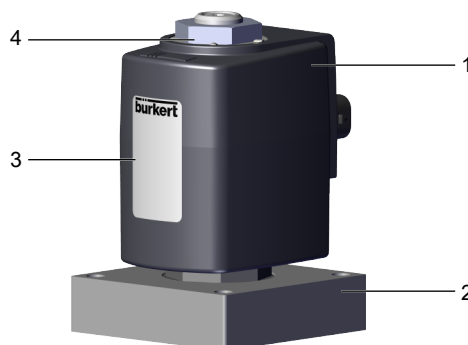

Fig. 2: Type 6020 flange variant (example: FK15)

1 Coil	2 Valve body
3 Type label	4 Nut for coil attachment

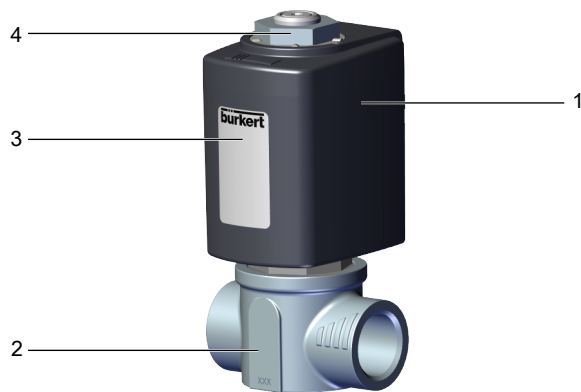

Fig. 3: Type 6020 socket variant (example: GM84)

1 Coil	2 Valve body
3 Type label	4 Nut for coil attachment

3.2 Product identification

3.2.1 Type label

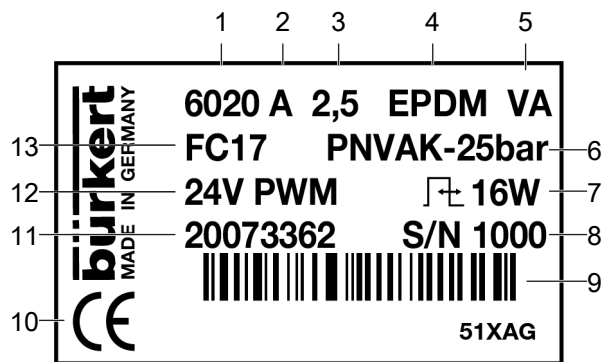

Fig. 4: Type 6020 type label (example)

1 Type	2 Circuit function
3 Orifice	4 Sealing material
5 Body material	6 Operating pressure
7 Nominal power	8 Serial number
9 Barcode	10 CE marking
11 Article number	12 Operating voltage
13 Port connection	

4 Technical data

4.1 Standards and directives

This product complies with the legal requirements applicable at the time of placing on the market and has been developed and tested in accordance with the relevant European directives/regulations and harmonized standards. The conformity is documented and, if necessary, supported by evidence. The EU Declaration of Conformity can be found behind the respective type on the home page country.burkert.com

4.2 Instructions for operating proportional valves

Proportional valves with the same identification number are set at the factory so that they have almost the same degree of opening and therefore a comparable flow level when operated with the same control unit. However, this only applies for identical operating conditions. The procedure depends on several influencing factors.

Operating behaviour with flow under the seat (Standard)

- **Input pressure:** As the input pressure decreases, the duty cycle or current required to reach the opening point of the valve increases. The maximum specified input pressure must not be exceeded; otherwise, the shut-off function can no longer be guaranteed.
- **Back pressure:** The back pressure has no influence on the opening start of the valve, but it does have an influence on the maximum achievable flow rate and the characteristic curve of the flow characteristic.

Operating behaviour with flow above the seat (V code MC13)

- **Input pressure:** As the input pressure decreases, the duty cycle or current required to reach the opening point of the valve decreases. The maximum specified input pressure must not be exceeded as otherwise the valve can no longer open or the nominal flow rate can no longer be achieved. A reliable shut-off function can be guaranteed in the event of short-term pressure peaks with flow above the seat.
- **Back pressure:** The back pressure has no influence on the opening start of the valve, but it does have an influence on the maximum achievable flow rate and the characteristic curve of the flow characteristic. At high back pressures, the control behaviour is influenced by increased linearity deviation of the flow characteristic.

Regardless of the flow, the thermal operating conditions also have an influence on the control behaviour of proportional valves: the duty cycle of the PWM signal for the opening start or a specific flow value of the valve is temperature-dependent. The ambient temperature and the self-heating of the valve are critical. When the coil is cold, a smaller duty cycle is sufficient to open the valve or achieve a desired flow value. However, the required duty cycle increases when the coil is at operating temperature and/or at higher ambient temperatures.

Operating behaviour at risk of frost: If there is moisture in the valve when it is cold and switched off, there is a risk of icing, which prevents opening and satisfactory control. In such cases, it is recommended to run through a warm-up phase without the operating medium present before commissioning. To do this, initially operate the valve with nominal voltage without current limitation

(100% duty cycle) for rapid heating. However, this process must not last longer than 5 minutes. Then, switch the valve several times (at least 5 times). During the closing process, observe the specifications for the valve control specified in the chapter [Operating conditions \[▶ 13\]](#).

4.3 Operating conditions

NOTICE!

High pressure surges

Liquids and high differential pressure may cause high pressure surges.



Valve control specification

To give the valve seat seal an unlimited service life, the valve should not be repeatedly switched off abruptly during normal operation.

It is recommended to implement a ramp time of at least 0.2 s when switching off the valve.

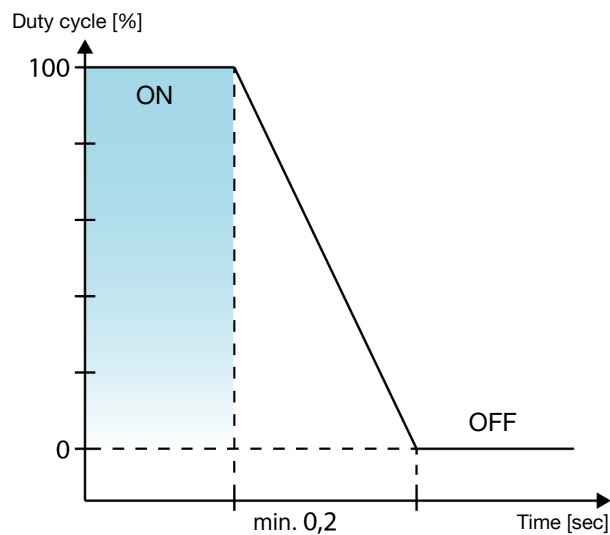

Fig. 5: View of closing ramp

Operating mode	<p>Unless otherwise specified on the type label, the solenoid actuator is suitable for continuous operation.</p> <p>Maximum coil current:</p> <p>AC19:</p> <ul style="list-style-type: none"> • 24 V to maximum 70 °C ambient temperature: 810 mA • 24 V to maximum 85 °C ambient temperature: 760 mA • 12 V to maximum 70 °C ambient temperature: 1530 mA • 12 V to maximum 85 °C ambient temperature: 1430 mA <p>AC10:</p> <ul style="list-style-type: none"> • 24 V SG5 to maximum 85°C ambient temperature: 310 mA • 24 V SG6 to maximum 85°C ambient temperature: 340 mA • 12 V SG5 to maximum 85°C ambient temperature: 600 mA • 12 V SG6 to maximum 85°C ambient temperature: 630 mA
Medium	neutral gases, pure hydrogen, natural gas, others on request
Installation position	Any, preferably actuator face up
Medium temperature	-40...+90 °C EPDM -10...+90 °C FKM
Ambient temperature	-40...+85 °C (7/16W, with EPDM) -40...+70 °C (18W, with EPDM) -10...+85 °C (7/16W, with FKM) -10...+70 °C (18W, with FKM)
Storage temperature	-40...+80 °C EPDM -20...+80 °C FKM
Materials	See data sheet
Protection classes (in accordance with VDE 0580)	I (standard coil) III (coil with automotive plug)
Degree of protection (EN 60529 / IEC 60529)	IP65 ¹⁾
Degree of protection (NEMA 250)	4X ²⁾
Degree of protection (ISO 20653)	IP6K, IPX7 (immersion test in accordance with ISO 16750-4), IPX9K ³⁾ (not applicable to variant FK01)

1) With correctly connected cable plug.

2) With correctly connected Type 2509 cable plug for VA variants (other variants on request).

3) The degree of protection requires a permanently mounted coil. Except for variant FK01 (disassembly required for installation).

4.4 Circuit function

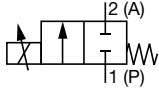
Icon	Description
	<p>Circuit function A (CF A), NC 2/2-way magnet proportional valve, direct-acting Normally closed</p>

Tab. 1: Circuit function

5 Installation



Risk of injury or material damage when working on the device or system.

- ▶ Read and observe the chapter **Safety** [▶ 7] before working on the device or system.

5.1 Preparatory work



DANGER!

Risk of injury from high pressure and discharge of medium.

- ▶ Before working on the device or system, switch off the pressure. Vent or drain lines.
- ▶ Clear pipes of any dirt.
- ▶ Fit a dirt trap on a dirty medium before the valve inlet (mesh size 0.2...0.4 mm).
- ▶ Devices that are suitable for use with food according to the manufacturer should be flushed for 5 minutes prior to start-up.
- ▶ Seal pipe connections using an elastomer seal or PTFE tape. Ensure that seal material does not get into the device.

5.2 Cable plug installation



CAUTION!

If there is no protective conductor function, there is a risk of injury from electric shock.

- ▶ Always connect the protective conductor.
- ▶ Check electrical continuity between solenoid and valve body.

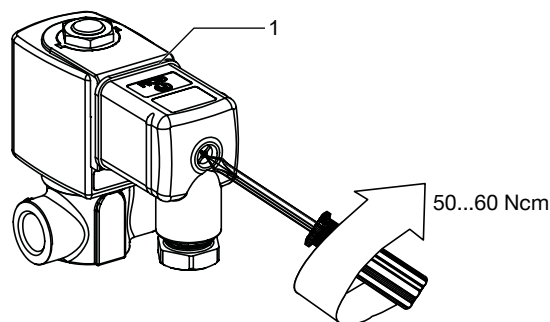

Fig. 6: Install the cable plug

1 Seal

- ▶ Attach the cable plug (for permitted types, see data sheet) to the contacts on the coil.
- ▶ Check that the seal is properly fitted.
- ▶ Tightly screw cable plug, while observing a tightening torque between 50 Ncm and 60 Ncm.

- ▶ Connect the protective conductor.
- ▶ Check electrical continuity between coil and body.

5.3 Installation of socket variants



Fig. 7: Installation of socket variants (example: GM84)

- ▶ Note flow direction: see data sheet
- ▶ Ensure that the seal surfaces on the body port connections are free of any damage.
- ▶ Hold the device on the valve body using an open-end wrench and screw into the pipeline.

NOTICE!

- ▶ Be sure not to damage the seal surfaces on the body port connections when screwing into the pipeline.

5.4 Cartridge variant installation



Fig. 8: Installation of cartridge variants (example FC17)

- ▶ Ensure that the O-rings on the valve body and the seal surfaces of the connection housing are free of any damage.
- ▶ Recommendation: Coat O-rings on the body in a suitable lubricant to prevent damage.

- ▶ Press the valve into the connection housing.
- ▶ Tightly screw in the retaining plate crosswise, observing the tightening torque indicated in the following table.

NOTICE!

- ▶ Ensure that the O-rings on the valve body and the seal surfaces of the connection housing are not damaged during installation.

Variant	Tightening torque [Nm]	Screws
FC17	6	M5 (screws not included in the scope of delivery)

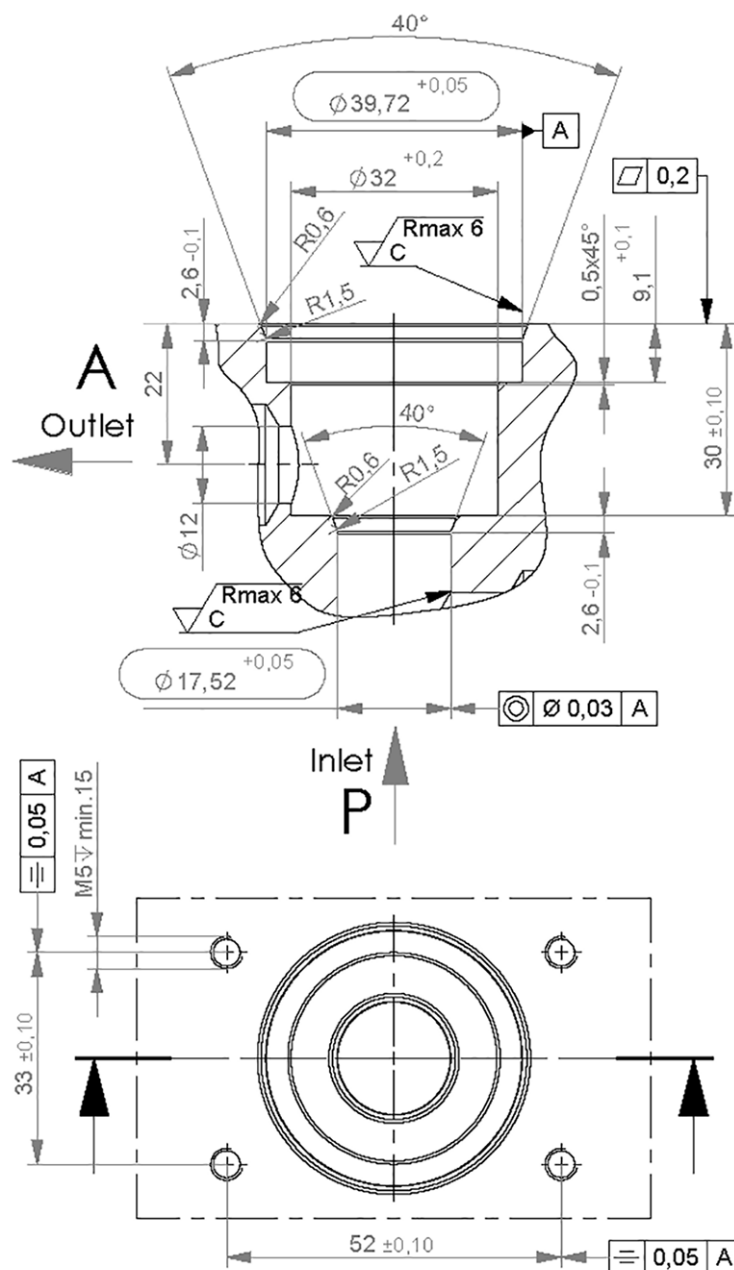

Fig. 9: Cartridge variant FC17 connection diagram

Variant	Tightening torque [Nm]	Screws
FC24	10	M6 (screws not included in the scope of delivery)

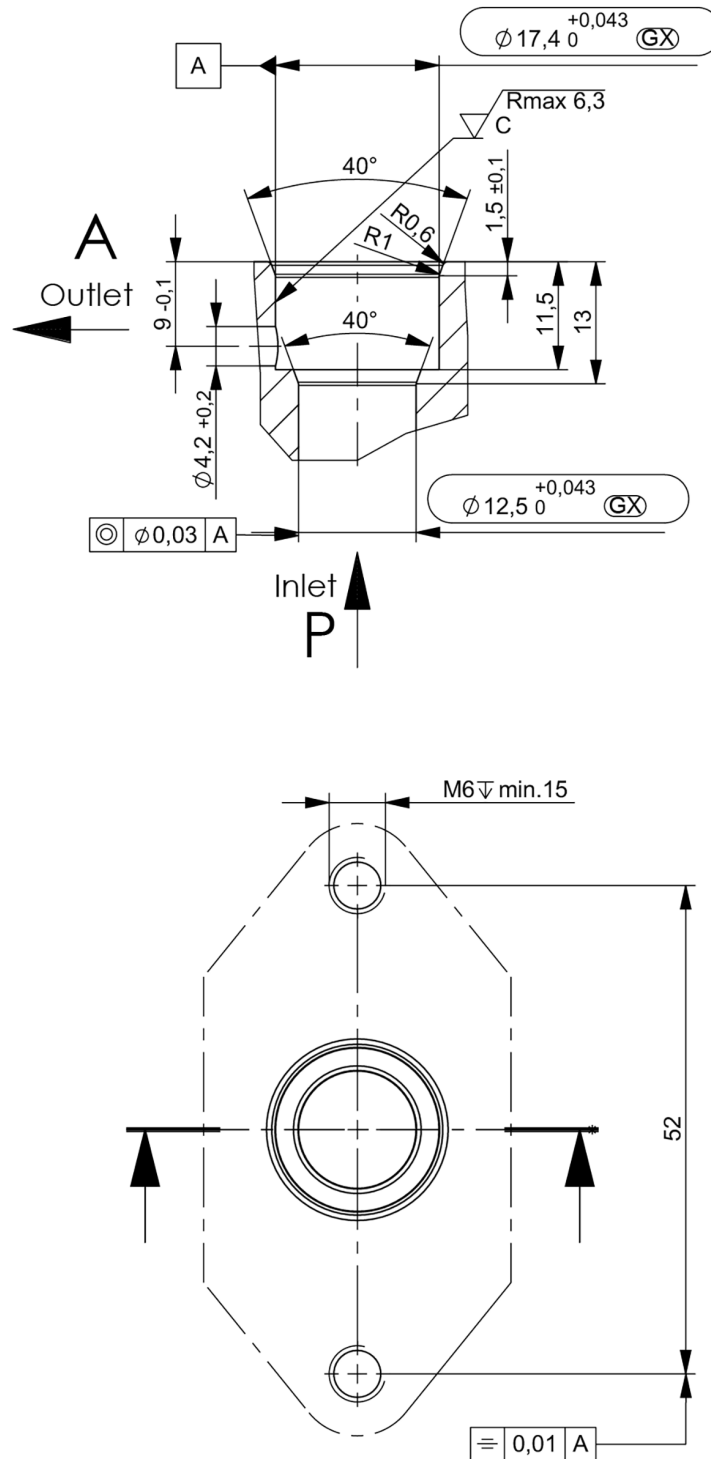

Fig. 10: Cartridge variant FC24 connection diagram

5.5 Flange variant installation

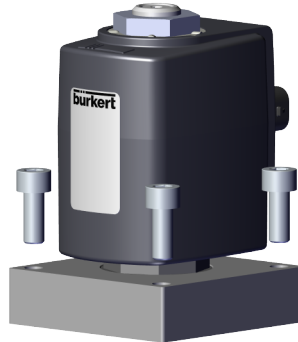

Fig. 11: Flange variant installation (example FK15)

- ▶ Ensure that the O-rings on the valve body and the seal surfaces of the connection housing are free of any damage.
- ▶ Place the valve on the connection housing.
- ▶ Tightly screw in the valve body crosswise, observing the tightening torque indicated in the following table.

NOTICE!

- ▶ Ensure that the O-rings on the valve body and the seal surfaces of the connection housing are not damaged during installation.

Variant	Tightening torque [Nm]	Screws
FK15	6	M5 (screws not included in the scope of delivery)

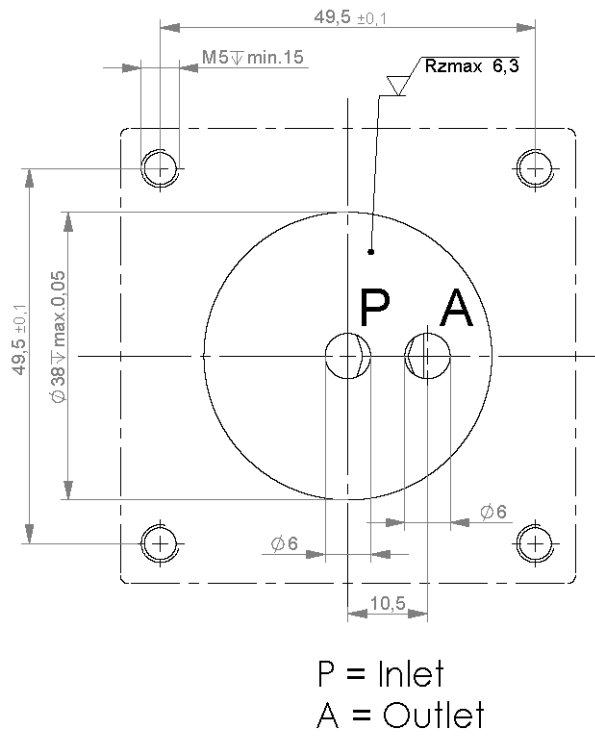

Fig. 12: Connection diagram for flange variant FK15

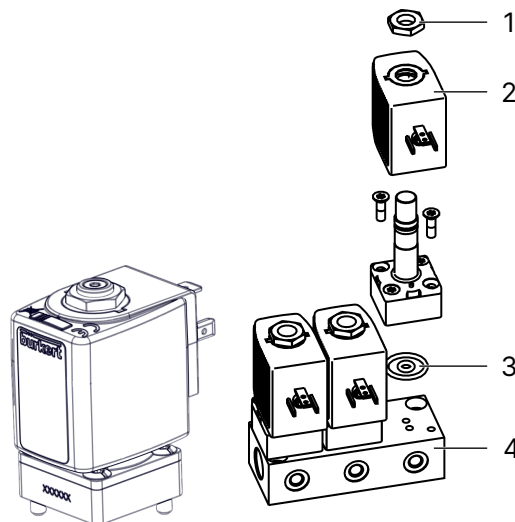
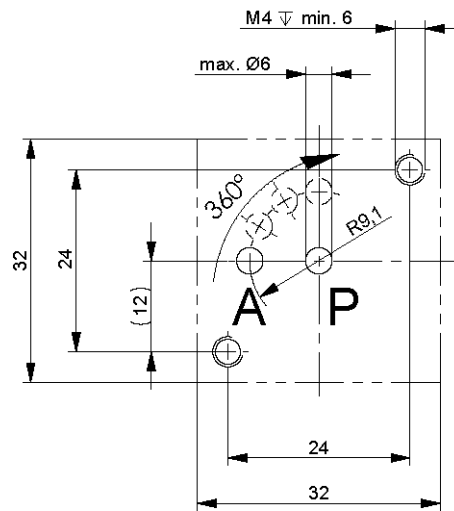

Fig. 13: Flange variant FK01 installation

1 Nut	2 Coil
3 Seal	4 Manifold

Variant	Operation	Tightening torque [Nm]	Screws
FK01	Mount the housing on the manifold	1,5	M4
	Mount the coil and tighten the nut	5	



P = Inlet
A = Outlet

Fig. 14: Flange variant FK01 connection diagram

5.6 Coil installation



WARNING!

Risk of injury due to medium leak

Medium may leak if a firmly fastened nut is loosened.

- ▶ Do not continue to rotate firmly fastened nuts.



CAUTION!

Risk of injury from electric shock

If there is no protective conductor contact between the solenoid and the body, there is a risk of electric shock.

- ▶ The anti-twist device (plastic ring) must be inserted into the body pins during installation. It must not protrude over the octagonal nipple.
- ▶ Check the protective conductor function after installing the solenoid.

NOTICE!

Overheating of coil, fire hazard

Connecting the coil without a pre-installed valve will cause overheating and destroy the coil.

- ▶ Only connect the coil after the valve has been installed.

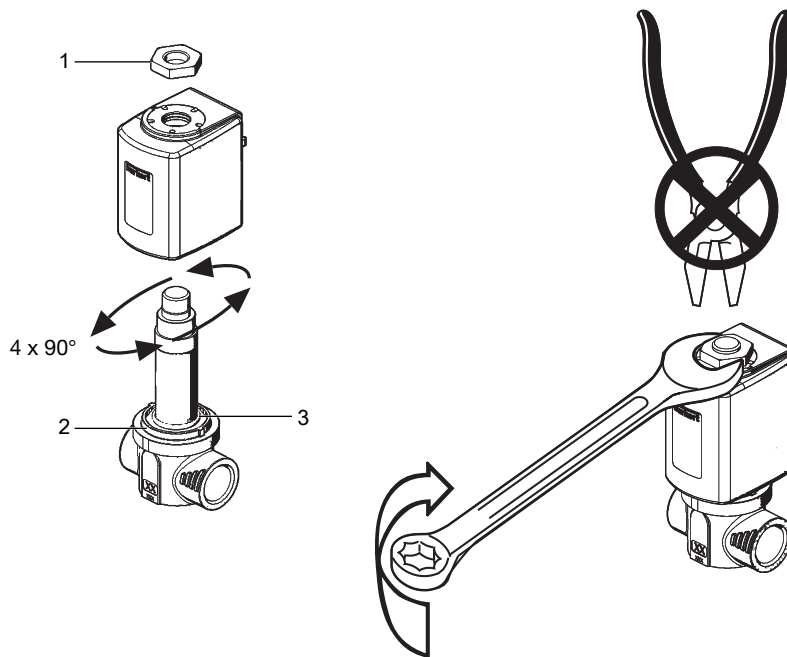

Fig. 15: Coil installation

1 Nut

2 Anti-twist device (only available for AC10 and socket variant AC19)

3 O-ring

- ▶ Check the correct positioning of the O-ring on the valve body.
- ▶ Slide the coil onto the core guide tube. Make sure that the anti-twist device is fully inserted into the journal. It must not protrude axially over the octagonal nipple (only for AC19).
- ▶ Fasten the nut with an open-end wrench. When screwing in, observe the tightening torque indicated in the following table.
- ▶ Check protective conductor function.

Variant	Tightening torque [Nm]
AC10	5
AC19	15

Tab. 2: Tightening torque during coil installation

6 Electrical connection

WARNING!

Risk of injury from electric shock.

- ▶ Switch off the power supply before working on the device or system. Secure it against reactivation.
- ▶ Observe the applicable accident prevention and safety regulations for electrical devices.

6.1 Cable plug Type 2518, plug shape A according to DIN EN 175301-803



Other cable plug variants can be found on the data sheet for Type 2518 at country.burkert.com.



Fig. 16: Cable plug Type 2518, plug shape A according to DIN EN 175301-803

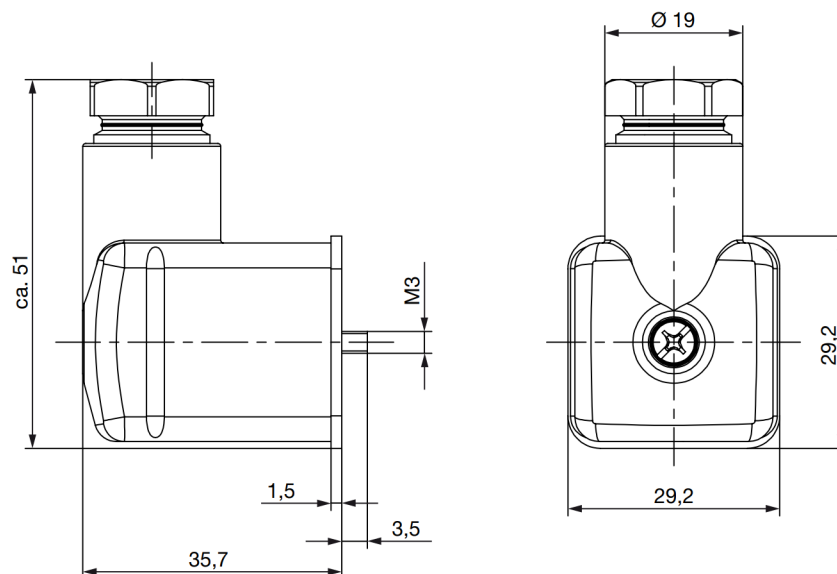

Fig. 17: Cable plug dimensions Type 2518



Further information, such as wiring and electrical values can be found on the data sheet for Type 2518 at country.burkert.com.

6.2 Automotive connectors for IP6K9K coil variants side by side

For mobile applications, coils are provided with the following automotive plugs:

- KOSTAL MLK1.2 plug, 2-pin, coding A (male)
- TE MCON 1.2 plug, 2-pin, coding A (male)

Customer-specific plug forms available on request.

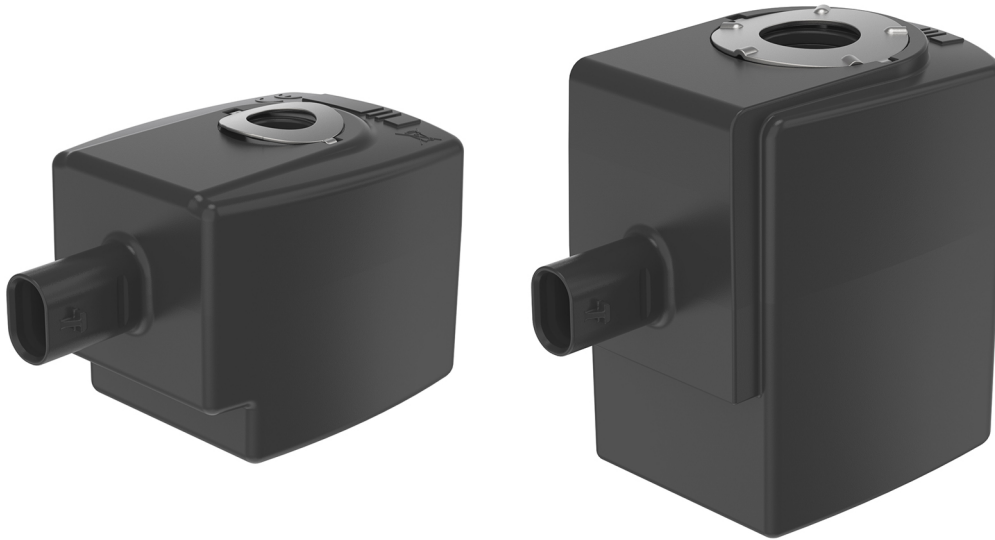

Fig. 18: Automotive plugs for IP6K9K coil variants

7 Faults



DANGER!

Risk of injury from high pressure and discharge of medium.

- ▶ Before working on the device or system, switch off the pressure. Vent or drain lines.



WARNING!

Risk of injury from electric shock.

- ▶ Switch off the power supply before working on the device or system. Secure it against reactivation.
- ▶ Observe the applicable accident prevention and safety regulations for electrical devices.

Error	Possible cause	Remedy
No flow	No supply pressure	Check supply pressure
	Valve connections switched	Check if pressure applied to valve is correct (see installation chapter)
	Electrical connection faulty	Check if electrical contacts and supply voltage are correct
	Filter clogged	Check filter and clean if necessary
Flow value not reached	Input pressure level too low	Check if sufficient input pressure level is present for desired flow
	Other pressure drop in system	Check filter for soiling. Check armatures and lines in system for sufficient dimensioning
	Supply voltage is too low	Adjust supply voltage (see operating conditions)
	Ambient temperature too high and/or average modulation too high	Reduce ambient temperature Adjust valve layout
	Valve layout not correct	Contact Bürkert contact person
Increased noise development	PWM frequency not coordinated to valve	Set recommended PWM frequency
	Vibration stimulation present in system	If possible, reduce pressure level If possible, increase cable cross-section Otherwise, contact Bürkert contact person

8 Logistics

8.1 Transport and storage

- ▶ Protect the device against moisture and dirt in the original packaging during transportation and storage.
- ▶ Avoid UV radiation and direct sunlight.
- ▶ Protect connections, if present, from damage with protective caps.
- ▶ Observe the permitted storage temperature.

8.2 Disposal

Environmentally friendly disposal



- ▶ Follow national regulations regarding disposal and the environment.
- ▶ Collect electrical and electronic devices separately and dispose of them as special waste.

Further information at country.burkert.com