

Type 2707

Hose pinch valve with pneumatic actuator



Operating Instructions

We reserve the right to make technical changes without notice.

© Bürkert Werke GmbH & Co. KG 2024-2026

Technical documentation 2603/04_GBen_60038359_958741771_45035997232483851 / Original DE

Contents

1	About this document	4
1.1	Symbols	4
1.2	Terms and abbreviations	5
1.3	Manufacturer	5
2	Safety	6
2.1	Intended use	6
2.2	Safety instructions	6
3	Product description	10
3.1	Product structure	10
3.2	Product identification	12
3.2.1	Type label	12
3.3	Function	12
3.3.1	Control functions	12
4	Technical data	13
4.1	Standards and directives	13
4.2	Operating conditions	13
5	Installation	14
5.1	Prepare the installation location	14
5.2	Mount the device on a installation plate	14
5.3	Insert hose	15
5.4	Connecting device pneumatically	15
5.4.1	Connect the CLASSIC variant pneumatically	15
5.4.2	Connect the ELEMENT variant pneumatically	16
5.4.3	Connect the INOX variant pneumatically	17
6	Maintenance	18
6.1	Maintenance and frequency	18
6.1.1	Maintenance	18
6.1.2	Actuator	18
6.2	Replace the compressor and hose holder	18
7	Troubleshooting	22
7.1	Actuator is not completely closed	22
7.2	Actuator is not fully opened	22
8	Spare parts and accessories	23
8.1	Ordering spare parts	23
8.2	Assembly tool for compressor	23
9	Logistics	24
9.1	Transport and storage	24
9.2	Return	24
9.3	Disposal	24

1 About this document

The document is an important part of the product and guides the user to safe installation and operation. The information and instructions in this document are binding for the use of the product.

- Before using the product for the first time, read and observe the whole safety chapter.
- Before starting any work on the product, read and observe the respective sections of the document.
- Keep the document available for reference and give it to the next user.
- Contact the Bürkert sales office for any questions.



Further information concerning the product at [Products](#).

- ▶ Enter the article number from the type label in the search bar.

1.1 Symbols



DANGER!

Warns of a danger that leads to death or serious injuries.



WARNING!

Warns of a danger that can lead to death or serious injuries.



CAUTION!

Warns of a danger that can lead to minor injuries.

NOTICE!

Warns of property damage on the product or the installation.



Indicates important additional information, tips and recommendations.



Refers to information in this document or in other documents.

▶ Indicates a step to be carried out.

✓ Indicates a result.

Menü Indicates a software user-interface text.

1.2 Terms and abbreviations

The terms and abbreviations are used in this document to refer to following definitions.

bar	Unit for relative pressure
Device	Hose pinch valve Type 2707

1.3 Manufacturer

Bürkert Fluid Control Systems

Christian-Bürkert-Str. 13-17

D-74653 Ingelfingen

The contact addresses are available at [Contact](#).



Need more information or additional products?

- ▶ Explore the full range of products on our [eShop](#).

2 Safety

2.1 Intended use

The device is designed to control the flow of media. The permissible media are listed in chapter [Technical data \[▶ 13\]](#)

Prerequisites for safe and trouble-free operation are proper transport, storage, installation, commissioning, operation and maintenance.

The instructions are part of the device. The device is intended exclusively for use within the scope of these instructions. Uses of the device that are not described in these instructions, the contractual documents or the type label can lead to severe personal injury or death, damage to the device or property and dangers for the surrounding area or the environment.

- ▶ Only trained and qualified personnel may install, operate and maintain the device. See qualification of persons in [Safety instructions \[▶ 6\]](#)
- ▶ Use the device only when it is in perfect condition.
- ▶ Use the device only in conjunction with third-party devices and components recommended and authorized by Bürkert.
- ▶ Only use devices that are approved for this type of potentially explosive atmosphere. These devices are labelled with the ATEX label on the type label. When using, always observe the details on the type label and the instructions for the potentially explosive atmosphere included in the scope of delivery for the device.
- ▶ Protect the device from environmental influences (e.g. radiation, humidity, vapours).

2.2 Safety instructions

Qualification of personnel working with the device

Improper use of the device can lead to serious personal injury or death. To avoid accidents when working with the device, the following minimum requirements must be met:

- ▶ Carry out work on the device within the scope of these instructions in a safety-compliant manner.
- ▶ Detect and avoid dangers when working on the device.
- ▶ Understand the instructions and implement the information contained therein accordingly.

Responsibility of the operator

The operator is responsible for observing the location-specific safety regulations, also in relation to personnel.

- ▶ Observe the general rules of technology.
- ▶ Install the device according to the regulations applicable in the respective country.
- ▶ The operator must make hazards arising from the location of the device avoidable by providing appropriate operating instructions.

Changes and other modifications, spare parts and accessories

Changes to the device, incorrect installation or use of non-approved devices or components create hazards that can lead to accidents and injuries.

- ▶ Do not make any changes to the device.
- ▶ Do not mechanically load the device.
- ▶ Observe the operating instructions of the device or component used.
- ▶ Only use the devices in conjunction with devices and components recommended or approved by Bürkert.

Spare parts and accessories that do not meet Bürkert's requirements may impair the operational safety of the device and cause accidents.

- ▶ To ensure operational safety, only use original parts from Bürkert.

Operation only after proper transport, storage, installation, start-up or maintenance.

Improper transport, storage, installation, start-up or maintenance endanger the operational safety of the device and can cause accidents. This can lead to serious personal injury or death.

- ▶ Only carry out works which are described in these instructions.
- ▶ Only carry out works using suitable tools.
- ▶ Have all other works carried out by Bürkert only.

Heavy device

During transportation or installation works, heavy devices may fall and cause injuries.

- ▶ Secure heavy device to keep it from tipping or falling over.
- ▶ If necessary, only transport, install and uninstall heavy device with the help of a second person.
- ▶ Use suitable tools.

Technical limit values and media

Non-compliance with technical limit values or unsuitable media can damage the device and lead to leaks. This can cause accidents and seriously injure or kill people.

- ▶ Comply with limit values. See [Technical data \[▶ 13\]](#) and information on the type label.
- ▶ Only feed media into the media ports that are listed in the chapter [Technical data \[▶ 13\]](#).
- ▶ Observe the safety data sheet for the media used.

Only use authorised devices in potentially explosive atmospheres

Devices that may be used in potentially explosive atmospheres are labelled with an Ex marking. Additional instructions with Ex labelling are included with these devices.

- ▶ Only use devices that are approved for use in a potentially explosive atmosphere.
- ▶ For use in potentially explosive atmospheres, observe the information on the device.
- ▶ For use in potentially explosive atmospheres, observe the additional instructions with Ex labelling.
- ▶ Do not use devices that do not have this Ex labelling and additional instructions in potentially explosive atmospheres under any circumstances.

Medium under pressure

Medium under pressure can seriously injure people. In the event of overpressure or pressure surges, the device or lines can burst. Pneumatic lines that are defective or not securely fastened can come loose and swing around.

- ▶ Before working on the device or system, switch off the pressure. Vent or empty the lines.

- ▶ Adhere to the permitted pressure ranges of the medium.
- ▶ Comply with the permitted temperature ranges of the medium.

Contaminated pilot air

The control exhaust air of the device can be contaminated with lubricants and damage the health of people and the environment.

- ▶ Dissipate control exhaust air appropriately.
- ▶ Wear appropriate personal protective equipment when working near the device.

If exhaust air from other processes is used to generate compressed air for the device, seals may be destroyed by the media contained in the exhaust air and cause medium to escape.

- ▶ Only use fresh air for generating compressed air for the device.

Hot surfaces and fire hazard

The surface of the device can become hot with fast-switching actuators or with hot media.

- ▶ Wear suitable protective gloves.
- ▶ Keep highly flammable substances and media away from the device.

Electric shock due to electrical components

Touching live parts can result in severe electric shock. This can lead to serious personal injury or death.

- ▶ Before working on the device or system, switch off the power supply. Secure it against reactivation.
- ▶ Observe any applicable accident prevention and safety regulations for electrical devices.

Hearing damage due to high noise level

Depending on the operating conditions, the device may generate loud noises.

- ▶ If the noise level exceeds 75 dB(A), wear hearing protection when near the device.

Working on the device

Working on the device that has not been powered down, unauthorised switching on or uncontrolled start-up of the system can cause accidents. This can lead to serious personal injury or death.

- ▶ Only work on the device when it is not in use.
- ▶ Ensure that the device or system cannot be switched on unintentionally.
- ▶ Only start the process in a controlled manner following disruptions. Observe sequence:
 1. Apply supply voltage or pneumatic supply.
 2. Charge the device with medium.

Mechanical moving parts

- ▶ Do not reach into openings.

The actuator contains a pre-tensioned spring. If the actuator is opened, there is a risk of injury if the spring pops out.

- ▶ Do not open the actuator. Unless an instruction explicitly describes how to open it.
- ▶ Do not open the actuator.
- ▶ Operate 3-position actuator with transparent cap only.

Danger from wear and tear on device

If there is wear and tear, medium can leak out of the relief bore and people may be seriously injured.

- ▶ Relief bore must be regularly inspected for any medium leakages.
- ▶ If media are hazardous, safeguard the environment around the relief bore.

The device can become leak at the valve seat if there is wear and tear.

- ▶ Check device regularly and change the wearing parts if necessary.

Potential equalisation – danger due to incorrect connection

Incorrectly executed potential equalisation can cause life-threatening situations.

- ▶ Establish potential equalisation exclusively via the external ground connection provided for this purpose. A plastic hose is not suitable for this purpose.
- ▶ Before start-up, check the need for potential equalisation and ensure that the correct connection. These tasks are entirely the responsibility of the operator.

3 Product description

The pneumatic hose pinch valve Type 2707 regulates the flow of media. The hose pinch valve consists of a pneumatically operated piston actuator with optical position indicator and a valve body into which a hose can be inserted.

3.1 Product structure

The device is a pneumatic hose pinch valve and consists of an actuator (CLASSIC, ELEMENT or INOX) and a valve body with hose carrier.

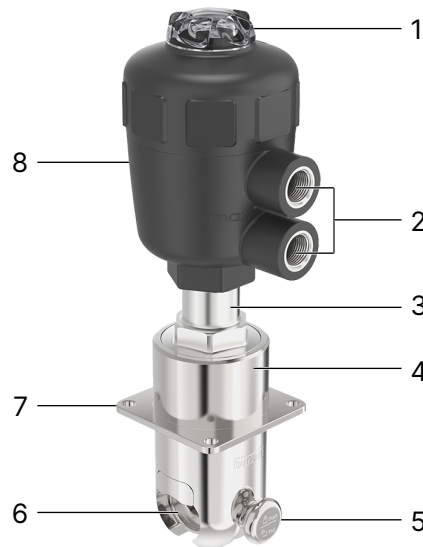

Fig. 1: Structure of the hose pinch valve, CLASSIC variant, example

1	Transparent cap with position indicator	2	Pilot air ports
3	Tube	4	Valve body
5	Handle	6	Hose carrier
7	Fixing plate	8	Actuator

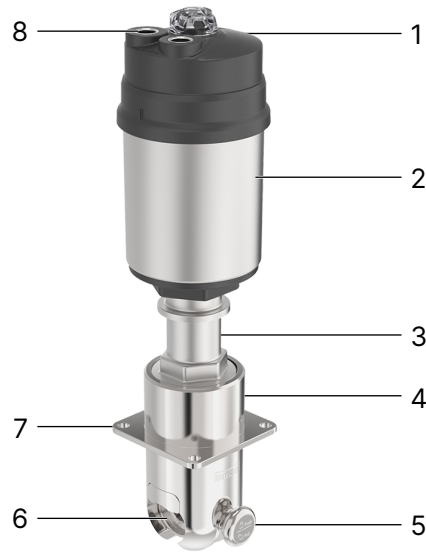

Fig. 2: Structure of the hose pinch valve, ELEMENT variant, example

1	Transparent cap with position indicator	2	Actuator
3	Tube	4	Valve body
5	Handle	6	Hose carrier
7	Fixing plate	8	Pilot air ports

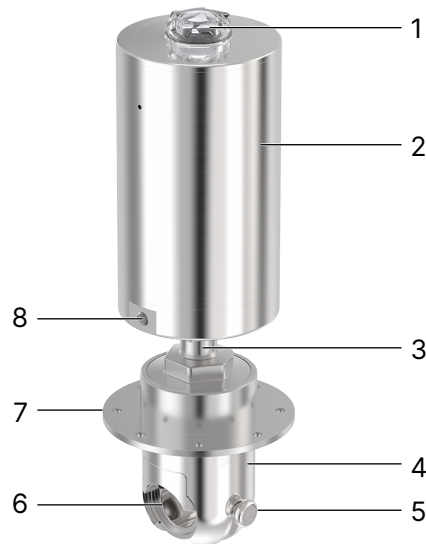

Fig. 3: Structure of the hose pinch valve, INOX variant, example

1	Transparent cap with position indicator	2	Actuator
3	Tube	4	Valve body
5	Handle	6	Hose carrier
7	Fixing plate	8	Pilot air port

3.2 Product identification

3.2.1 Type label

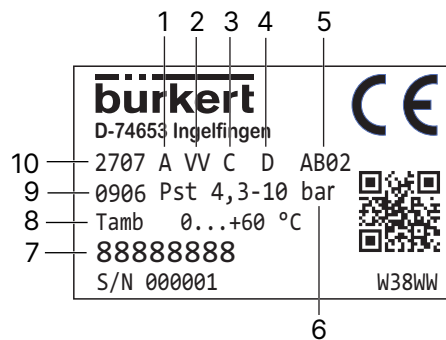

Fig. 4: Type label Type 2707 (example)

1	Control function	2	Material: body material and hose carrier
3	Actuator variant	4	Actuator size
5	Pilot air port connection	6	Pilot pressure
7	Article number	8	Ambient temperature
9	Outer diameter and inner diameter of the hose	10	Type

3.3 Function

The hose pinch valve uses the deformation of a flexible hose to regulate the flow. Depending on the variant, the valve is closed against the medium flow either with spring action (control function A, CFA) or pilot pressure (control function B, CFB). Spring action (CFA) or pneumatic pilot pressure (CFB) generate the closing force on the compressor. The force is transmitted through a spindle connected to the actuator piston. The closing force on the compressor ultimately compresses the hose and thus interrupts the media flow. By removing the closing force, the hose returns to its original shape and the flow is released again.

3.3.1 Control functions

Control function A (CFA), NC (normally closed)

Closed by spring force in rest position.

Control function B (CFB), NO (normally open)

Opened by spring force in rest position.

Control function I (CFI), double-acting

Actuating function via reciprocal pressurisation.

4 Technical data

4.1 Standards and directives

The device complies with the valid EU harmonisation legislation.

The harmonised standards that have been applied for the conformity assessment procedure are listed in the current version of the EU Declaration of Conformity.

4.2 Operating conditions

Ambient temperature	Actuator: 0...+60 °C Hose: see specifications of the hose manufacturer
Medium temperature	See specifications of the hose manufacturer
Air humidity	approx. 98%
Operating pressure	See specifications of the hose manufacturer
Control medium	Neutral gases, air
Pilot pressure	4.5...8 bar
Installation position	Any, preferably actuator face up

5 Installation



Risk of injury or material damage when working on the device or system.

- ▶ Read and observe the chapter [Safety \[▶ 6\]](#) before working on the device or system.

5.1 Prepare the installation location

- ▶ Ensure that the device is suitable for the application.
- ▶ Observe suitable protective equipment in accordance with the system operator's regulations.
- ▶ Shut down the system.
- ▶ Secure the system against being switched on again.
- ▶ Depressurise the system.
- ▶ Completely drain the system.
- ▶ Note the installation position.

5.2 Mount the device on a installation plate

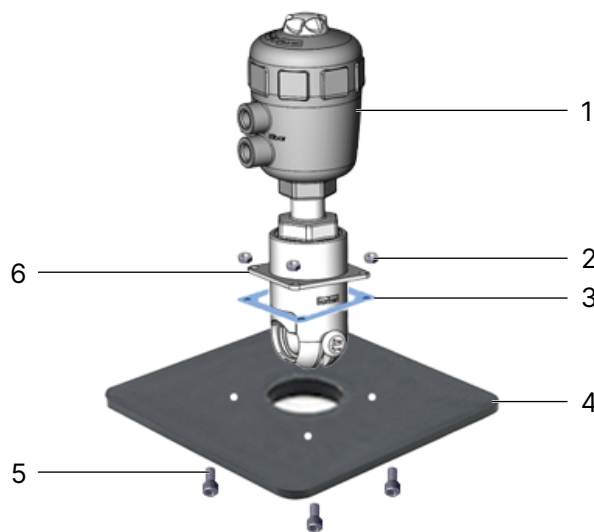

Fig. 5: Attach device

1 Hose pinch valve	2 Nut
3 Seal	4 Installation plate
5 Socket head screws	6 Fixing plate

- ▶ Prepare the installation plate:
Prepare the installation plate according to the drilling pattern shown in the data sheet.
- ▶ Insert seal:
Place the seal onto the installation plate according to the contour of the device.

► Install the device:

Guide the device through the recess in the installation plate and secure it to the fixing plate with 4 socket head screws or to the 8-hole flange using 8 socket head screws.



When using a seal with IP protection, tighten the socket head screws with a tightening torque of 4 Nm (CLASSIC and ELEMENT variants) or 7 Nm (INOX variant).

5.3 Insert hose



WARNING!

Risk of crushing

- When opening and closing the device, do not reach into the pinch area of the hose.
- Before working on the device, move the actuator into the open position.



WARNING!

Risk of injury from connection of unsuitable hoses

Inappropriate hoses can come loose and swing around.

- Use only hoses which are authorised for the indicated pressure and medium temperature range.
- Observe the data sheet specifications from the hose manufacturers.

NOTICE!

Lay hose lines properly.

Incorrectly routed hoses lead to malfunctions and increase the risk of accidents.

- Do not kink or twist hose lines.
 - Do not exceed the maximum bending radius of the line.
 - Observe the data sheet specifications from the hose manufacturers.
- Attach the hose to the hose carrier provided.

5.4 Connecting device pneumatically

5.4.1 Connect the CLASSIC variant pneumatically

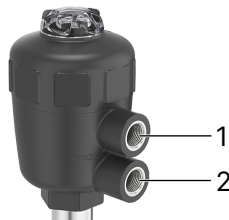

Fig. 6: Pneumatic pilot air ports, CLASSIC variant

1 Pilot air port top

2 Pilot air port bottom

Control function	Pilot air port bottom	Pilot air port top
B: normally open	x	+
A: normally closed	+	x
I: double-acting	+	+

+ = connection required

x = no connection required



Install the control medium line without tension or kinks.

- ▶ Devices with control function A: Screw the control medium line into the lower pilot air port.
- ▶ Devices with control function B: Screw the control medium line into the upper pilot air port.
- ▶ Devices with control function I: Screw the control medium line into the upper and lower pilot air port.

5.4.2 Connect the ELEMENT variant pneumatically

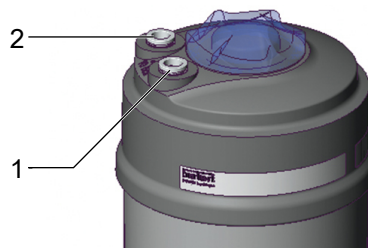

Fig. 7: Pneumatic pilot air ports, ELEMENT variant

	1 Pilot air port 1	2 Pilot air port 2
Control function	Pilot air port 1	Pilot air port 2
B: normally open	+	x
A: normally closed	+	x
I: double-acting	+	+

+ = connection required

x = no connection required



Install the control medium line without tension or kinks.

- ▶ Devices with control function A: Connect the control medium line to pilot air port 1.
- ▶ Devices with control function B: Connect the control medium line to pilot air port 1.
- ▶ Devices with control function I: Connect the control medium line to pilot air port 1 and 2.

5.4.3 Connect the INOX variant pneumatically



Fig. 8: Pneumatic pilot air ports, INOX variant

	1 Pilot air port 1	2 Pilot air port 2
Control function	Pilot air port 1	Pilot air port 2
B: normally open	x	+
A: normally closed	+	x
I: double-acting	+	+

+ = connection required

x = no connection required



Install the control medium line without tension or kinks.

- ▶ Devices with control function A: Screw the control medium line into pilot air port 1.
- ▶ Devices with control function B: Screw the control medium line into pilot air port 2.
- ▶ Devices with control function I: Screw the control medium line into pilot air port 1 and 2.

6 Maintenance



Risk of injury or material damage when working on the device or system.

- ▶ Read and observe the chapter **Safety** [▶ 6] before working on the device or system.

6.1 Maintenance and frequency

6.1.1 Maintenance

The device operates maintenance-free if the instructions in this operating instructions are followed.

6.1.2 Actuator

The valve actuator is maintenance-free if the instructions in these operating instructions are followed.

6.2 Replace the compressor and hose holder

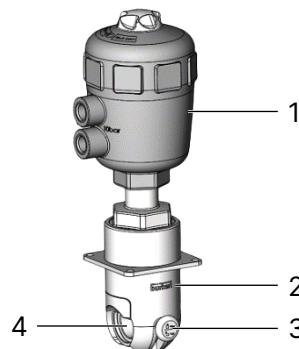

Fig. 9: Replace the compressor

1 Actuator	2 Valve body
3 Handle	4 Hose carrier



WARNING!

Risk of crushing

- ▶ When opening and closing the device, do not reach into the pinch area of the hose.
- ▶ Before working on the device, move the actuator into the open position.
- ▶ Move the actuator into the open position.

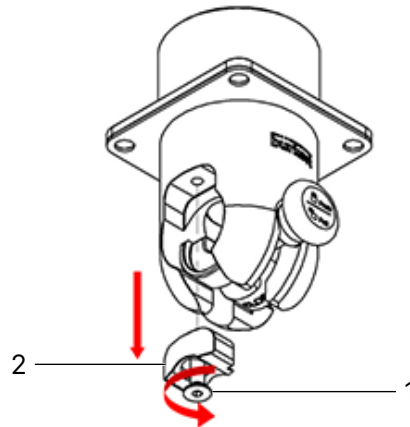

1 Locking screw

2 Locking part

- ▶ Loosen the locking screws on the valve body with an Allen key and remove the locking part.

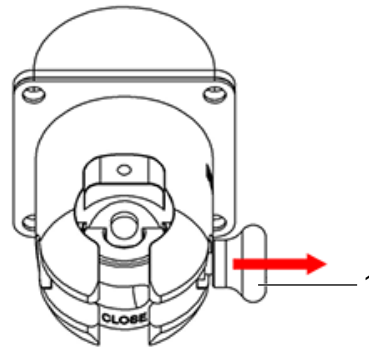

1 Handle

- ▶ Pull the handle out until it clicks into place, then push it downwards by 90°.

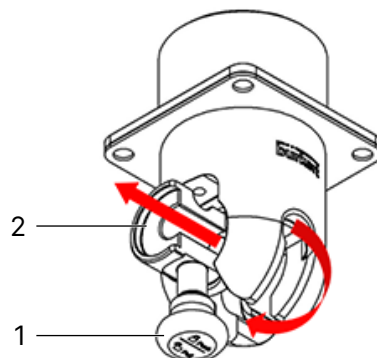

1 Handle

2 Hose carrier

- ▶ Slide out the hose carrier.
- ▶ Move the actuator to the closed position.

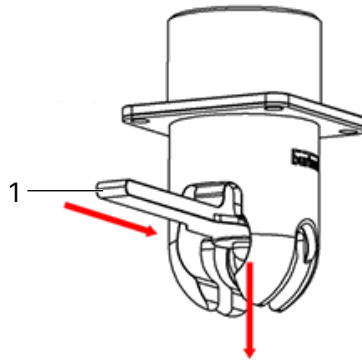

1 Assembly tool for compressor

- ▶ Insert the compressor assembly tool into the compressor slot and pull the compressor off the spindle.

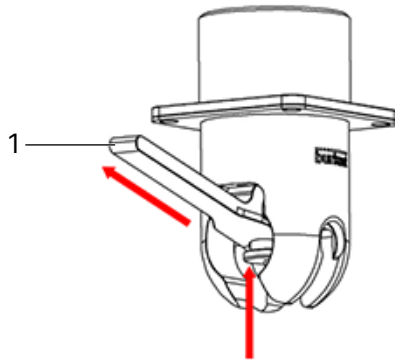

1 Assembly tool for compressor

- ▶ Insert new compressor.
Make sure that the centre hole of the compressor is exactly aligned with the centre of the spindle.
- ▶ Press the compressor firmly until you feel it click into place in the spindle.
- ▶ Move the actuator into the open position.

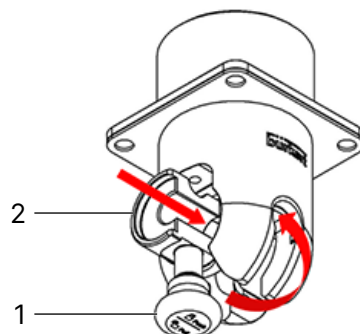

1 Handle

2 Hose carrier

- ▶ Insert the hose carrier into the guide groove of the valve body.
- ▶ Pull out the handle and push it up 90°.

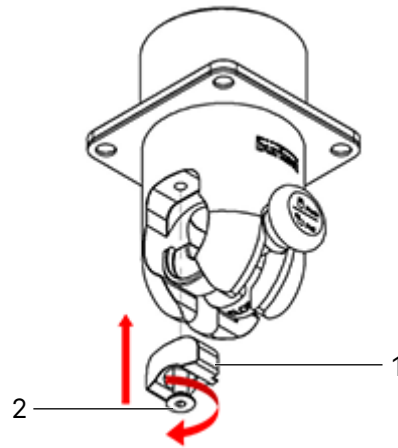

1 Locking part

2 Locking screw

- ▶ Refit the locking part and tighten the retaining screw to a tightening torque of 2 Nm using an Allen key (CLASSIC and ELEMENT variants) or 2.5 Nm (INOX variant).

7 Troubleshooting

7.1 Actuator is not completely closed

Cause	Solution
Insufficient spring action of the actuator.	▶ Contact the manufacturer and replace the actuator.
Operating pressure too high.	▶ Observe the pressure data of the hose manufacturer.
Leaky or damaged hoses.	▶ Check hoses and replace if necessary.

7.2 Actuator is not fully opened

Cause	Solution
Actuator defective.	▶ Replace the actuator.
Pilot pressure too low.	▶ Observe pressure data on the type label.
Dirt on the valve seat.	▶ Clean the valve seat.
Actuator variant is not suitable for the actual usage conditions.	▶ Contact the manufacturer and replace the actuator.

8 Spare parts and accessories



Risk of injury and/or damage due to incorrect parts.

- ▶ Use only original accessories and original spare parts from Bürkert.



Order the parts directly on our [eShop](#).

8.1 Ordering spare parts

Spare parts can be ordered via the Bürkert [eShop](#) or via the Bürkert home page.

Order via the e-shop

- ▶ Visit the [Bürkert eShop](#).
- ▶ Log in or register.
- ▶ Enter the article number of the device in the search box.
- ▶ Select spare parts and complete your order.

Order via the Bürkert home page

- ▶ Link [View](#) spare parts sets.
- ▶ Enter the article number of the device in the search box.
- ▶ Select spare parts and complete your order.

8.2 Assembly tool for compressor



Actuator size	Article number
50 (D)	93201284
63 (E)	93201313
100 (G)	93202731
100 (G)	93202730

9 Logistics

9.1 Transport and storage

- ▶ Protect the device against moisture and dirt in the original packaging during transportation and storage.
- ▶ Avoid UV radiation and direct sunlight.
- ▶ Protect connections from damage with protective caps.
- ▶ Observe permitted storage temperature.

9.2 Return



No work or tests will be carried out on the device until a valid Contamination Declaration has been received.

- ▶ To return a used device to Bürkert, contact the Bürkert sales office. A return number is required.

9.3 Disposal

Environmentally friendly disposal



- ▶ Follow national regulations regarding disposal and the environment.
- ▶ Collect electrical and electronic devices separately and dispose of them as special waste.

Further information at country.burkert.com