

Type 2051

Pneumatic rotary actuator



Operating Instructions

We reserve the right to make technical changes without notice.

© Bürkert Werke GmbH & Co. KG 2008-2026

Technical documentation 2602/05_GBen_00805791_907520267_18014399830788747 / Original DE

Table of contents

1	About this document	4
1.1	Symbols	4
1.2	Terms and abbreviations	5
1.3	Manufacturer	5
2	Safety	6
2.1	Intended use	6
2.2	Basic safety instructions	7
3	System description	8
3.1	Intended area of application	8
3.2	General description	8
3.3	Operating principle	8
4	Technical data	11
4.1	Standards and directives	11
4.2	Operating conditions	11
4.3	Mechanical data	11
4.4	Pneumatic data	11
4.5	Dimensions	11
5	Assembly / installation	12
5.1	Safety instructions	12
5.2	Installation	12
5.3	Pneumatic installation	12
6	Start-up	13
7	Operation and function	14
7.1	Safety instructions	14
7.2	Operating the rotary actuator	14
7.3	Function	14
8	Maintenance and troubleshooting	15
8.1	Safety instructions	15
8.2	Maintenance work	15
8.3	Replacement of sealing elements	16
8.3.1	Procedure for dismantling	17
8.3.2	Installation procedure	20
8.4	Troubleshooting	23
9	Spare parts	24
10	Decommissioning	25
10.1	Safety instructions	25
10.2	Dismantling the pneumatic rotary actuator	25
11	Logistics	26
11.1	Transport and storage	26
11.2	Return	26
11.3	Disposal	26

1 About this document

The document is an important part of the product and guides the user to safe installation and operation. The information and instructions in this document are binding for the use of the product.

- ▶ Before using the product for the first time, read and observe the whole safety chapter.
- ▶ Before starting any work on the product, read and observe the respective sections of the document.
- ▶ Keep the document available for reference and give it to the next user.
- ▶ Contact the Bürkert sales office for any questions.



Further information concerning the product at [Products](#).

- ▶ Enter the article number from the type label in the search bar.

The illustrations in these instructions may vary depending on the product variant.

1.1 Symbols



DANGER!

Warns of a danger that leads to death or serious injuries.



WARNING!

Warns of a danger that can lead to death or serious injuries.



CAUTION!

Warns of a danger that can lead to minor injuries.

NOTICE!

Warns of property damage on the product or the installation.



Indicates important additional information, tips and recommendations.



Refers to information in this document or in other documents.

- ▶ Indicates a step to be carried out.

✓ Indicates a result.

Menu Indicates a software user-interface text.

1.2 Terms and abbreviations

The terms and abbreviations are used in this document to refer to following definitions.

Product	Pneumatic rotary actuator Type 2051
---------	-------------------------------------

1.3 Manufacturer

Bürkert Fluid Control Systems

Christian-Bürkert-Str. 13-17

74653 Ingelfingen

GERMANY

The contact addresses are available at [Contact](#).



Need more information or additional products?

- ▶ Explore the full range of products on our [eShop](#).

2 Safety

2.1 Intended use

Unauthorised use of the pneumatic rotary actuator Type 2051 may be dangerous to people, nearby equipment and the environment.

- ▶ The pneumatic rotary actuator Type 2051 has been designed to operate swivel fittings such as ball valves or butterfly valves. It can be used both indoors and outdoors in compliance with the permissible usage conditions.
- ▶ The pneumatic rotary actuator Type 2051 may be used only in conjunction with third-party devices and components recommended or approved by Bürkert.
- ▶ When deploying the device, observe the authorised data, and the operating and usage conditions specified in the contract documents and operating instructions. They are described in chapter 6. Technical data.
- ▶ The prerequisites for safe and trouble-free operation are correct transport, storage and installation as well as careful operation and maintenance.
- ▶ Use the pneumatic rotary actuator Type 2051 only as intended.

Restrictions

If required, observe existing restrictions when exporting the system/device.

Foreseeable misuse

The pneumatic rotary actuator Type 2051 may not be operated with corrosive gases, water or hydraulic oil (for applications with these media, please contact your Bürkert sales department).

- ▶ Do not feed any aggressive, corrosive or explosive media into the media ports of the system.
- ▶ Do not feed any liquids into the media connections.
- ▶ Do not place the housing under mechanical stress (e.g. by placing objects on it or standing on it).
- ▶ Do not make any external alterations to the device housings. Do not paint housing parts or screws!

2.2 Basic safety instructions

These safety instructions do not take account of any:

- ▶ unforeseen occurrences or events that may arise during installation, operation or maintenance of the devices.
- ▶ local safety regulations that are within the operator's scope of responsibility, including those relating to the installation personnel.



DANGER!

Danger from high pressure

- ▶ Before loosening lines or valves, switch off the pressure and vent the lines.

General hazardous situations

Ensure the following to prevent injuries:

- ▶ The system cannot be activated unintentionally.
- ▶ Installation and maintenance tasks must always be performed by authorised technicians, using the appropriate tools.
- ▶ The process must be restarted in a defined or controlled manner after an interruption in the power supply or pneumatic supply.
- ▶ The device may only be operated in perfect condition and in accordance with the operating instructions.
- ▶ The generally accepted engineering standards must be followed when planning and operating the device.



The pneumatic rotary actuator Type 2051 has been developed with due consideration given to the accepted safety rules and is state-of-the-art. Nevertheless, dangerous situations can still occur.

Non-observance of these operating instructions and the information contained therein and unauthorised tampering with the device will release us from any liability and also invalidate the warranty covering devices and accessories!

3 System description

3.1 Intended area of application

The pneumatic rotary actuator Type 2051 has been designed to operate swivel fittings such as ball valves or butterfly valves.

3.2 General description



Fig. 1: Pneumatic rotary actuator

The pneumatic rotary actuator Type 2051 consists of a single or double-acting pneumatic linear piston actuator with internal coupling to a rotary piece and a universal mechanical interface in accordance with ISO 5211. During the linear movement of the piston under the pressure force of the pilot air or the force of the return springs, the actuator shaft is rotated through 90° by the coupling. The rotary movement can be used to actuate corresponding proportional valves such as ball valves or butterfly valves.

3.3 Operating principle

Control function A

Single-acting actuator, return by spring force, operation, e.g., with a pilot valve.

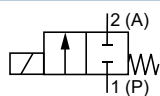

Circuit function A (CF A), NC
2/2-way solenoid valve, direct-acting
Normally closed

Control function B (on request)

Single-acting actuator, return by spring force.

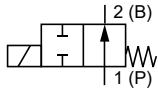

Circuit function B (CF B), NO
2/2-way solenoid valve, direct-acting
Normally open

Schematic representation of control function A (B)

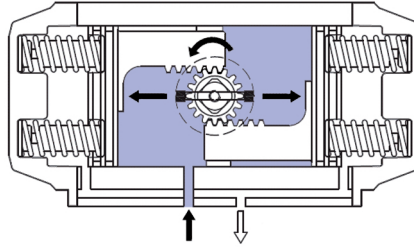

Connection 2 Connection 4

Fig. 2: Counterclockwise rotation (control function B: clockwise rotation)

Pilot air at connection 2 moves the pistons towards the actuator covers, tensioning the springs. A counterclockwise rotation is achieved. Exhaust air via connection 4.

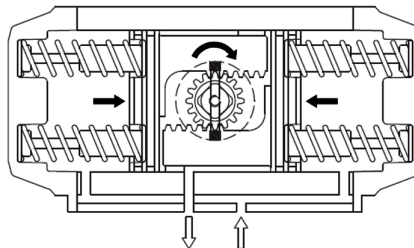

Connection 2 Connection 4

Fig. 3: Clockwise rotation (control function B: counterclockwise rotation)

Ventilation or compressed air failure at connection 2 allows the springs to move the pistons inwards. A clockwise rotation is achieved. Exhaust air via connection 2.

Control function I

Double-acting actuator, operation, e.g., with a pilot valve.

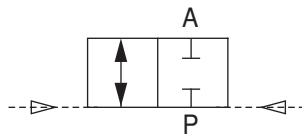

Schematic representation of control function I

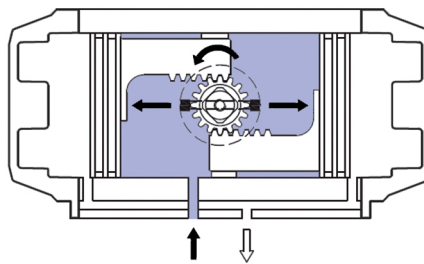

Connection 2 Connection 4

Fig. 4: Counterclockwise rotation

Pilot air at connection 2 moves the pistons towards the actuator covers. A counterclockwise rotation is achieved. Exhaust air via connection 4.

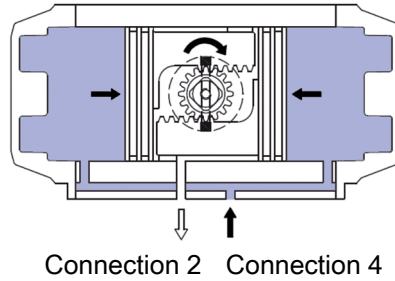

Fig. 5: Clockwise rotation

Pilot air at connection 4 moves the pistons inwards. A clockwise rotation is achieved. Exhaust air via connection 2.

4 Technical data

4.1 Standards and directives

This product complies with the legal requirements applicable at the time of placing on the market and has been developed and tested in accordance with the relevant European directives/regulations and harmonized standards. The conformity is documented and, if necessary, supported by evidence. The EU Declaration of Conformity can be found behind the respective type on the home page country.burkert.com

4.2 Operating conditions

Seal material	Ambient temperature
NBR special	-40...+80°C
FMK	-15...+150 °C
Storage temperature	-40...+40 °C

4.3 Mechanical data

Weight	depending on actuator design (see data sheet)
Housing material	coated, extruded aluminium alloy
Seal material	NBR special, FKM on request

4.4 Pneumatic data

Control medium	Filtered compressed air (maximum particle size 30 µm)
Pressure range	3 to 8 bar single-acting actuator 2.5 to 8 bar double-acting actuator
Air flow rate	depending on the actuator size (see data sheet)
Connections	depending on the actuator size (see data sheet)

4.5 Dimensions

Dimensions	see data sheet
------------	----------------

5 Assembly / installation

5.1 Safety instructions



DANGER!

Risk of injury from high pressure in the system

- ▶ Before loosening lines or valves, switch off the pressure and vent the lines.



WARNING!

Risk of injury due to improper installation

- ▶ Installation must be carried out by authorised technicians only and with the appropriate tools.



WARNING!

Risk of injury from unintentional activation of the system and uncontrolled restart

- ▶ Secure the system against unintentional activation.
- ▶ Ensure a controlled restart after installation.

5.2 Installation



For installation, observe the operating instructions of the respective valve.

5.3 Pneumatic installation

The rotary actuators can be installed in any position. Prior to installation:

- ▶ Ensure that the mechanical connection between the rotary actuator and the armature fits snugly to prevent friction.
- ▶ Connect the pilot air lines to the connections provided for this purpose on the rotary actuator.

6 Start-up



WARNING!

Risk of injury from discharge of pressure

Poorly connected pilot air lines may become loose under pressure.

- ▶ Make sure that the line connections of the pilot air are connected firmly to the corresponding ports of the rotary actuator.



WARNING!

Risk of injury due to improper operation

Improper operation may result in injuries as well as damage to the device and the surrounding area.

- ▶ Before start-up, ensure that the operating personnel are aware of and have completely understood the contents of the operating instructions.
- ▶ The safety instructions and the intended use must be observed.
- ▶ Only adequately trained personnel may start up the system/device.

7 Operation and function

7.1 Safety instructions



WARNING!

Danger due to improper operation.

Improper operation may result in injuries as well as damage to the device and its surroundings.

- ▶ The operating personnel must know and have understood the contents of the operating instructions.
- ▶ The safety instructions and the intended use must be observed.
- ▶ The system/device must always be operated by properly trained personnel.

7.2 Operating the rotary actuator

The pneumatic rotary actuator is operated by means of compressed air (up to 8 bar), depending on the function. This can be fed directly or via attached pilot valves into the corresponding connections on the rotary actuator.

7.3 Function

For operating principles, see chapter [System description \[▶ 8\]](#)

8 Maintenance and troubleshooting

8.1 Safety instructions



DANGER!

Risk of injury from high pressure in the system

- ▶ Before loosening lines or valves, switch off the pressure and vent the lines.



WARNING!

Risk of injury due to improper maintenance work

- ▶ Maintenance must be carried out by authorised technicians using the appropriate tools!



WARNING!

Risk of injury from unintentional activation of the system and uncontrolled restart

- ▶ Secure the system against unintentional activation.
- ▶ Ensure a controlled restart after maintenance is completed.

8.2 Maintenance work

To ensure a long service life for the rotary actuators, maintenance is recommended every 500,000 to 1,000,000 switching operations. If necessary, the corresponding sealing elements must be replaced (see chapter 10.3. Replacing the sealing elements below).

During continuous operation or in harsh environmental conditions, it is recommended to relubricate the moving parts (e.g. pistons, racks) in the actuator with silicone-free grease.

A prerequisite for a long service life is that the rotary actuator is operated with filtered compressed air.

8.3 Replacement of sealing elements

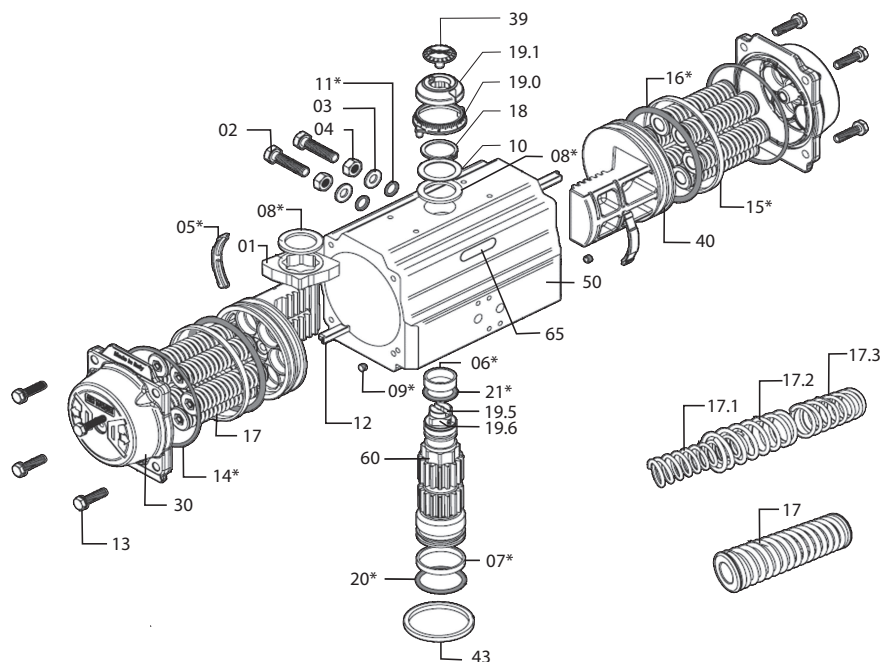

Fig. 6: Overview of designs

Position	Quantity	Description
01	1	Cams (valve timing adjustment)
02	2	Stop screw
03	2	Plain washer
04	2	Stop lock nut
05*	2	Piston guide jaws
06*	1	Shaft bearing bushing (top)
07*	1	Shaft bearing bushing (bottom)
08*	2	Thrust washer
09*	2	Stopper
09.1*	2	Sealing ring (for AT 801 U)
10	1	Supporting washer
11*	2	Seal (adjusting screw)
12	2	Piston bearing
13	8/12/16	Cover screw
14*	2	Cover seal
15*	2	Piston guide band
16*	2	Piston seal

Position	Quantity	Description
17	min. 5/max. 12	Compression spring cartridge
17.1	max. 2	Compression spring (for AT045U + AT051U)
17.2	max. 2	Compression spring (for AT045U + AT051U)
17.3	max. 2	Compression spring (for AT045U + AT051U)
18	1	Circlip (shaft)
19	1	Position indicator (for AT051U + AT101U)
19.0	1	Scale ring
19.1	1	Position indicator
19.5	1	Adapter at the top
19.6	2	Socket head screw
20*	1	Shaft seal (bottom)
21*	1	Shaft seal (top)
30	2	Cover
39	1	Screw (position indicator)
40	2	Piston
43	1	Centring (on request)
50	1	Housing
60	1	Shaft
65	1	Plastic insert

* Recommended spare parts

8.3.1 Procedure for dismantling

NOTICE!

If the actuator needs to be dismantled for maintenance, first remove the actuator from the valve.



Before dismantling, ensure that:

- ▶ The actuator is not under pressure and the springs are in their end position.
- ▶ Connections 2 and 4 are not under pressure and are free of any accessories or devices.



If the actuator is single-acting, ensure that:

- ▶ The actuator is in its normal position and the pistons are fully retracted.

Removing the position indicator and scale ring (item 19, 19.0, 19.1)

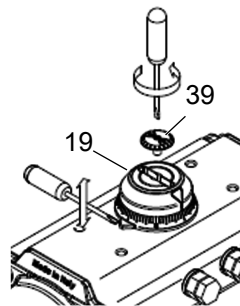

Fig. 7: Removing the position indicator

- ▶ Remove screw (item 39) (if present).
- ▶ Remove the position indicator (item 19 or 19.1) from the shaft. If necessary, use a screwdriver as a lever.
- ▶ Lift the scale ring (item 19.0) off the housing. If necessary, use a screwdriver as a lever.

Removal of the adjusting screws (item 02)

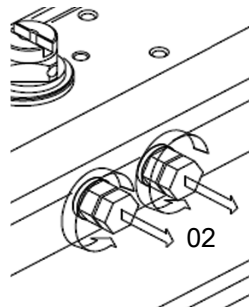

Fig. 8: Removing the adjusting screws

- ▶ Remove both adjusting screws together with the nut (item 04) and washer (item 03).
- ▶ Remove and discard the seals (item 11) from the adjusting screws (if all sealing rings are being replaced).

Removal of the covers (item 30)



WARNING!

Risk of injury when removing the cover!

When dismantling a single-acting actuator, loosen the cover screws alternately. If force is still exerted on the covers after turning the screws, this may indicate that a spring cartridge is damaged or that the pistons have not been fully retracted. Further removal of the cover may result in serious injury to maintenance personnel.

- ▶ Stop removing immediately.
- ▶ Return the actuator to the supplier.

Unscrew the cover screws in sequence.

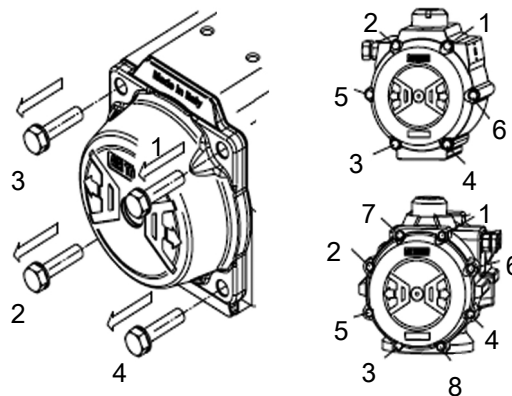

Fig. 9: Cover removal

Removing the cover of the single-acting actuator (remove one cover after the other):

- ▶ Unscrew the cover screws (item 13) until the covers are no longer under spring force.
- ▶ Completely unscrew the screws.
- ▶ Remove the cover and the springs.

Removing the cover of the double-acting actuator (remove one cover after the other):

- ▶ Unscrew the cover screws until they are completely removed and the covers are loose.
- ▶ Remove the O-rings using a screwdriver.
- ▶ Dispose of sealing rings (if these are being replaced).

Removal of pistons (item 40)

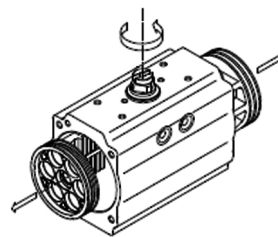

Fig. 10: Removal of the pistons



WARNING!

Risk of injury due to projectile impact.

- ▶ Do not use compressed air to remove the pistons from the housing.
- ▶ Secure the housing (item 50) with a vice or similar tool.
- ▶ Turn the shaft until the pistons are released.
- ▶ Remove the O-rings (item 16) with a screwdriver.
- ▶ Remove the piston guide jaws (item 05) and the piston guide bands (item 15).
- ▶ Dispose of the straps and jaws.

Removing the shaft (item 60)

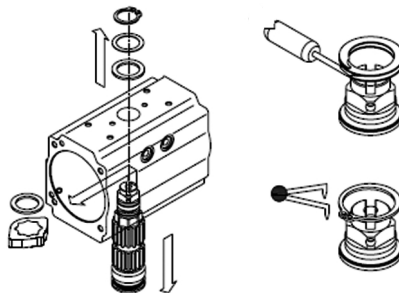

Fig. 11: Shaft extension

- ▶ Carefully remove the scale ring with a screwdriver and the circlip with circlip pliers.
- ▶ Remove the plain washer and the outer thrust washer.
- ▶ Press lightly on the top of the shaft (item 60) until it is possible to remove the inner thrust washer (item 08) and the cams.
- ▶ Remove the shaft from the housing. If the shaft does not come out easily, carefully tap the upper end of the shaft with a plastic hammer.
- ▶ Remove the upper (item 06) and lower (item 07) shaft bearing bushings and the upper (item 20) and lower (item 21) shaft seals.
- ▶ Dispose of and replace the bushings (items 06 and 07), inner and outer thrust washers and sealing rings (if necessary, also replace the plugs (item 09)).

NOTICE!

All removed and non-replaced designs must be cleaned and checked for wear before being reinstalled.

8.3.2 Installation procedure



Before installation, ensure that:

- ▶ All components are clean and in perfect state.
- ▶ The spare parts and grease are suitable for the operating temperature of the actuator.
- ▶ The lubricants are suitable for the different operating temperatures.

Installation of the shaft (item 60)

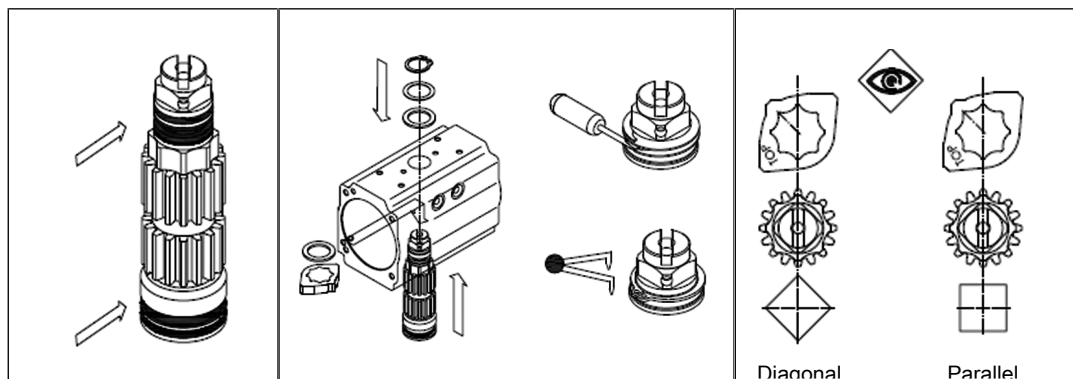

Fig. 12: Installation of the shaft

- ▶ Install the upper (item 06) and lower (item 07) shaft bearing bushes, grease the lower (item 20) and upper (item 21) sealing rings and fit them onto the shaft.
- ▶ Grease the surface of the shaft at the top and bottom.
- ▶ Insert the shaft partially into the housing (item 50), install the cam (item 01) in the desired position relative to the upper and lower ends of the shaft and the direction of rotation of the actuator in operation. Insert the inner thrust washer (item 08). Install the shaft completely onto the housing.
- ▶ Install the outer thrust washer (item 08), the supporting washer (item 10) and the outer circlip (item 18) using circlip pliers.

Installation of the pistons (item 40)

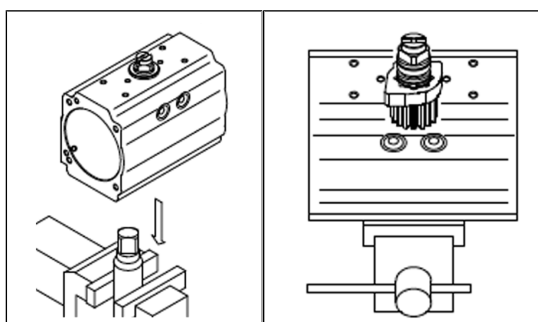

Fig. 13: Installation of the pistons

- ▶ Grease and install the O-rings (item 16), piston guide jaws (item 05) and piston guide band (item 15).
- ▶ Grease the inner surface of the housing (item 50) and the piston racks (item 40).
- ▶ Place the socket (item 60) on a sufficiently secured coupling.
- ▶ Ensure that the cam is in the correct position (see Figure 13).
- ▶ For standard direction of rotation installation, variant ST (clockwise closing), turn the housing (item 50) 40–45° clockwise (see Figure 14).

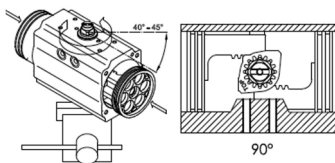

Fig. 14: Turn the housing clockwise

- ▶ Insert both pistons (item 40) into the housing (item 50) at the same time and press them in until the pistons are engaged, then turn the housing anticlockwise until the stroke is complete.
- ▶ When the pistons are fully retracted, ensure that the rotation achieved in relation to the axis of the housing is slightly more than 0° and that dimension A is the same on both sides (see Figure 15).

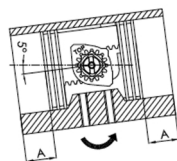

Fig. 15: Check dimension A

Installation of the covers (item 30)

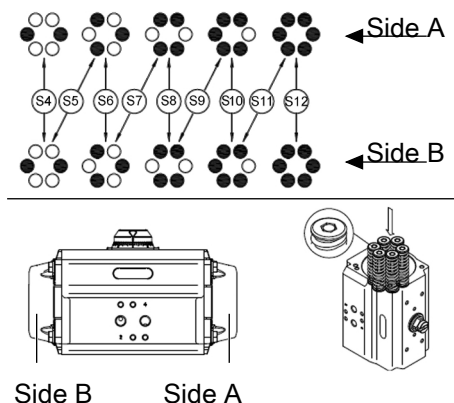

Fig. 16: Cover installation

- ▶ Grease the housing.
- ▶ For single-acting actuators, insert the springs into the cover according to the desired configuration.
- ▶ Insert the cover seal (item 14) into the groove.
- ▶ Place the covers on the housing (item 50) and check that the O-rings remain in the groove.
- ▶ Insert the cover screws (item 13) and tighten them in sequence (see Figure 9).

Installation of the adjusting screws

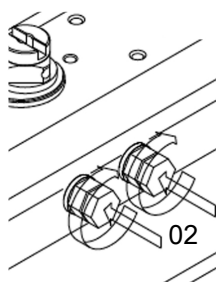

Fig. 17: Installation of the adjusting screws

- ▶ Insert the adjusting screws (item 02), the nut (item 04), the washer (item 03) and the O-ring.
- ▶ Screw the adjusting screws (item 02) into the housing.

End position setting for the standard actuator (clockwise closing)

- ▶ 0° (close) end position adjustment: with the actuator in the closed position, unscrew the right-hand adjusting screw until the desired end position is reached. To secure, tighten the nut (item 04).
- ▶ 90° (open) end position adjustment: unscrew the left-hand adjusting screw until the desired end position is reached. To secure, tighten the nut (item 04).

Installation of the scale ring and position indicator (items 19, 19.0, 19.1)

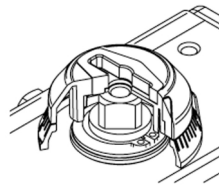

Fig. 18: Place the scale ring on the housing

- ▶ Place the scale ring (item 19.0) on the housing.
- ▶ Align the adapter (item 19.5) and secure it with suitable screws (item 19.6).
- ▶ Insert position indicator (item 19 or 19.1).
- ▶ Screw in the screw (item 39) of the position indicator.

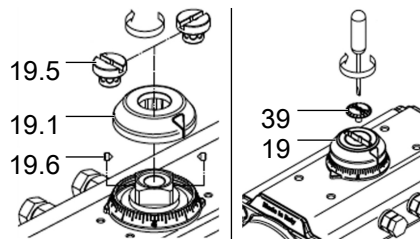

Fig. 19: Installation of the scale ring and position indicator

8.4 Troubleshooting

Blocking of the actuator

- ▶ Check whether the blockage is caused by the attached valve. If necessary, remove the rotary actuator from the valve.
- ▶ Check whether the pistons in the actuator are blocked. Here too, it is advisable to remove the actuator from the valve and test it separately. Replace the sealing elements in the actuator if necessary.

9 Spare parts



CAUTION!

Risk of injury and/or damage due to incorrect parts.

Incorrect accessories and unsuitable spare parts may cause injuries and damage the device and the surrounding area.

- ▶ Use only original accessories and original spare parts from Bürkert.

Complete spare part sets are offered as spare parts. Depending on the actuator size, these have the following order numbers.

Actuator size	Name	Order number
15	Spare parts kit HD38 Special NBR	770 811
30	Spare parts kit HD38 Special NBR	770 812
60	Spare parts kit HD38 Special NBR	770 813
100	Spare parts kit HD38 Special NBR	770 814
150	Spare parts kit HD38 Special NBR	770 815
220	Spare parts kit HD38 Special NBR	770 816
300	Spare parts kit HD38 Special NBR	770 817
450	Spare parts kit HD38 Special NBR	770 810

NOTICE!

If the actuator size is unknown, please provide the order number of the actuator when ordering spare part sets.

You can find information on replacing the sealing elements in chapter [Maintenance and troubleshooting](#) [▶ 15]

10 Decommissioning

10.1 Safety instructions



WARNING!

Risk of injury due to improper dismantling.

- ▶ Dismantling must always be carried out by authorised technicians and with the appropriate tools.

10.2 Dismantling the pneumatic rotary actuator



For dismantling, observe the operating instructions of the respective valve.

11 Logistics

11.1 Transport and storage

- ▶ Protect the device against moisture and dirt in the original packaging during transportation and storage.
- ▶ Avoid UV radiation and direct sunlight.
- ▶ Protect connections, if present, from damage with protective caps.
- ▶ Observe the permitted storage temperature.

11.2 Return



No work or tests will be carried out on the device until a valid Contamination Declaration has been received.

- ▶ To return a used device to Bürkert, contact the Bürkert sales office. A return number is required.

11.3 Disposal

Environmentally friendly disposal



- ▶ Follow national regulations regarding disposal and the environment.
- ▶ Collect electrical and electronic devices separately and dispose of them as special waste.

Further information at country.burkert.com