

Type 8756 Batch

Mass Dosing Controller



Operating Instructions

We reserve the right to make technical changes without notice.

© Bürkert Werke GmbH & Co. KG, 2021 - 2024

Operating Instructions 2412/04_GBen_00572214 / Original EN

Table of contents

1	About this document	6
1.1	Symbols	6
1.2	Terms and abbreviations	7
1.3	Manufacturer	7
2	Safety	8
2.1	Intended use	8
2.2	Safety instructions	8
3	Product description	11
3.1	Product overview	11
3.2	Product identification	13
3.2.1	Type label	13
3.2.2	Calibration label	13
3.2.3	Conformity marking	13
3.2.4	Symbols and markings on device	14
3.3	Display elements	14
3.3.1	Status indicator	14
3.3.2	NAMUR mode	14
3.3.3	Network status indicator	15
3.3.4	Communication indicator	15
3.4	Functionality	16
3.4.1	Service-büS interface	16
3.4.2	On/Off valve	16
3.4.3	Customised actuator	16
3.4.4	Service life of the on/off valve	17
3.4.5	Memory card	17
4	Technical data	18
4.1	Standards and directives	18
4.2	Operating conditions	18
4.3	Medium data	20
4.3.1	Calibration conditions	20
4.3.2	Operating medium	20
4.3.3	Density measurement	20
4.3.4	Temperature measurement	21
4.3.5	Mass flow rate measurement	21
4.3.6	Pressure loss	22
4.3.7	Dosing volume range	22
4.4	Electrical data	23
4.5	Communication	26
4.5.1	Industrial Ethernet: EtherCAT	26
4.5.2	Industrial Ethernet: EtherNet/IP	26
4.5.3	Industrial Ethernet: Modbus TCP	27
4.5.4	Industrial Ethernet: PROFINET IO	27
4.6	Mechanical data	27
5	Medium connection	28
5.1	Possible medium connections	28
5.2	Installation procedure	28

5.2.1	G1/8"-internal-threaded connections	29
5.2.2	NPT1/8"-internal-threaded connections	29
5.2.3	Connections with external-threaded vacuum fittings	29
5.2.4	Connections with external-threaded compression fittings	29
5.2.5	Tri-clamp connections	30
6	Electrical connection	31
6.1	Additional documentation	31
6.2	Wire the variant bÜS /CANopen	31
6.2.1	With bÜS extension cables from Bürkert	31
6.2.2	With bÜS cables from Bürkert	31
6.2.3	With CANopen cables	32
6.3	Wire the variant Industrial Ethernet	33
6.4	Change the network parameters	34
6.4.1	Over the product web-server	35
6.4.2	Over the Bürkert Communicator software	35
6.5	Connect the functional earth	36
6.6	Connect the external actuator	36
6.6.1	Connection examples with Bürkert valves	37
7	Commissioning	38
7.1	Commissioning procedure	38
8	Configuration with Bürkert Communicator	39
8.1	Setting tools	39
8.2	Connect to the Bürkert Communicator	39
8.3	Dosing types	41
8.3.1	Quantity based dosing	41
8.3.2	Start the dosings	41
8.3.3	Cyclic data (PDOs)	41
8.4	Functions	45
8.4.1	Bubble detection	45
8.4.2	Flush bubbles from the pipe	46
8.4.3	Unexpected flow detection	46
8.4.4	Detect the end of dosings	46
8.4.5	Configure the actuator	47
8.4.6	Configure the controller	47
8.4.7	Monitor the actuator switching cycles	48
8.4.8	Reset the maintenance interval	48
8.5	Set the CANopen communication or the bÜS communication	48
8.6	Transmission speeds of cyclic data	49
8.6.1	Change the transmission speed of a single PDO	49
8.6.2	Temporarily increase the transmission speed of all PDOs	49
8.7	Changing between bÜS and CANopen mode	50
9	Maintenance	51
9.1	Replace the memory card	51
9.2	Replace the on/off valve Type 6013	52
9.3	Replace the on/off valve Type 6724	53
9.4	Replace the on/off valve Type 6757	53
10	Troubleshooting	55
10.1	Problems shown by the PDO3, Error ID	55

10.2	Status indicator is red	55
10.3	Status indicator is orange	55
10.4	Status indicator is yellow	56
10.5	Status indicator is blue	57
10.6	Status indicator is off	57
10.7	Status indicator flashes	58
10.8	Status indicator goes out periodically	58
10.9	Replacement device adopts none of the values from the defective device	58
10.10	Replacement device does not adopt all of the values from the defective device	58
10.11	Unstable measured value	59
10.12	Outgassing or bubble formation at the device outlet	59
10.13	Dosing quantity cannot be reached	59
10.14	Quantity is not dosed precisely	60
10.15	Dripping	60
10.16	Network status indicator	60
11	Spare parts and accessories	61
11.1	Electrical accessories	61
11.2	Additional software	62
12	Uninstallation	63
12.1	Dismantling	63
13	Logistics	64
13.1	Transport and storage	64
13.2	Return	64
13.3	Disposal	64

1 About this document

The document is an important part of the product and guides the user to safe installation and operation. The information and instructions in this document are binding for the use of the product.

- Before using the product for the first time, read and observe the whole safety chapter.
- Before starting any work on the product, read and observe the respective sections of the document.
- Keep the document available for reference and give it to the next user.
- Contact the Bürkert sales office for any questions.



Further information concerning the product at [Products](#).

- ▶ Enter the article number from the type label in the search bar.

1.1 Symbols



DANGER!

Warns of a danger that leads to death or serious injuries.



WARNING!

Warns of a danger that can lead to death or serious injuries.



CAUTION!

Warns of a danger that can lead to minor injuries.

NOTICE!

Warns of property damage on the product or the installation.



Indicates important additional information, tips and recommendations.



Refers to information in this document or in other documents.

▶ Indicates a step to be carried out.

✓ Indicates a result.

Menü Indicates a software user-interface text.

1.2 Terms and abbreviations

The terms and abbreviations are used in this document to refer to following definitions.

Device	Type 8756 Batch
MDC	Mass Dosing Controller
büS	Bürkert system bus, a communication bus developed by Bürkert and based on the CANopen protocol
bar	Unit for relative pressure

1.3 Manufacturer

Bürkert Fluid Control Systems

Christian-Bürkert-Str. 13-17

74653 Ingelfingen

GERMANY

The contact addresses are available at [Contact](#).



Need more information or additional products?

► Explore the full range of products on our [eShop](#).

2 Safety

2.1 Intended use

The device MDC is designed to measure the mass flow rate of liquids and to dose small quantities of liquids.

The permitted media are listed in [Technical data \[▶ 18\]](#).

Prerequisites for safe and trouble-free operation are proper transport, storage, installation, commissioning, operation and maintenance.

The instructions are part of the device. The device is intended exclusively for use within the scope of these instructions. Uses of the device that are not described in these instructions, the contractual documents or the type label can lead to severe personal injury or death, damage to the device or property and dangers for the surrounding area or the environment.

- ▶ Only trained and qualified personnel may install, operate and maintain the device. See qualification of persons in [Safety instructions \[▶ 8\]](#)
- ▶ Use the device only in conjunction with third-party devices and components recommended and authorized by Bürkert.
- ▶ Use the device only when it is in perfect condition.
- ▶ Only use the device indoors.
- ▶ Do not open the device.
- ▶ Do not use the device in high-vibration areas.

2.2 Safety instructions

Qualification of personnel working with the device

Improper use of the device can lead to serious personal injury or death. To avoid accidents when working with the device, the following minimum requirements must be met:

- ▶ Carry out work on the device within the scope of these instructions in a safety-compliant manner.
- ▶ Detect and avoid dangers when working on the device.
- ▶ Understand the instructions and implement the information contained therein accordingly.

Responsibility of the operator

The operator is responsible for observing the location-specific safety regulations, also in relation to personnel.

- ▶ Observe the general rules of technology.
- ▶ Install the device according to the regulations applicable in the respective country.
- ▶ The operator must make hazards arising from the location of the device avoidable by providing appropriate operating instructions.

Electrostatically sensitive components and assemblies

The device contains electronic components that are susceptible to the effects of electrostatic discharging (ESD). Components that come into contact with electrostatically charged persons or objects are at risk. In the worst case scenario, these components will be destroyed immediately or fail after start-up.

- ▶ Meet the requirements specified by EN 61340-5-1 to minimise or avoid the possibility of damage caused by a sudden electrostatic discharge.
- ▶ Do not touch electronic components when the supply voltage is connected.

Electric shock due to electrical components

Touching live parts can result in severe electric shock. This can lead to serious personal injury or death.

- ▶ Before working on the device or system, switch off the power supply. Secure it against reactivation.
- ▶ Observe any applicable accident prevention and safety regulations for electrical devices.

Changes and other modifications, spare parts and accessories

Changes to the device, incorrect installation or use of non-approved devices or components create hazards that can lead to accidents and injuries.

- ▶ Do not make any changes to the device.
- ▶ Do not mechanically load the device.
- ▶ Observe the operating instructions of the device or component used.
- ▶ Only use the devices in conjunction with approved devices or components.

Spare parts and accessories that do not meet Bürkert's requirements may impair the operational safety of the device and cause accidents.

- ▶ To ensure operational safety, only use original parts from Bürkert.

Operation only after proper transport, storage, installation, start-up or maintenance.

Improper transport, storage, installation, start-up or maintenance endanger the operational safety of the device and can cause accidents. This can lead to serious personal injury or death.

- ▶ Only carry out works which are described in these instructions.
- ▶ Only carry out works using suitable tools.
- ▶ Have all other works carried out by Bürkert only.

Working on the device

Working on the device that has not been powered down, unauthorised switching on or uncontrolled start-up of the system can cause accidents. This can lead to serious personal injury or death.

- ▶ Only work on the device when it is not in use.
- ▶ Ensure that the device or system cannot be switched on unintentionally.
- ▶ Only start the process in a controlled manner following disruptions. Observe sequence:
 1. Apply supply voltage or pneumatic supply.
 2. Charge the device with medium.

Technical limit values and media

Non-compliance with technical limit values or unsuitable media can damage the device and lead to leaks. This can cause accidents and seriously injure or kill people.

- ▶ Comply with limit values. See **Technical data [▶ 18]** and information on the type label.
- ▶ Only feed media into the media ports that are listed in the chapter **Technical data [▶ 18]**.
- ▶ Observe the safety data sheet for the media used.

Medium under pressure

Medium under pressure can seriously injure people. In the event of overpressure or pressure surges, the device or lines can burst. Pneumatic lines that are defective or not securely fastened can come loose and swing around.

- ▶ Before working on the device or system, switch off the pressure. Vent or empty the lines.
- ▶ Adhere to the permitted pressure ranges of the medium.
- ▶ Comply with the permitted temperature ranges of the medium.

Hot surfaces and fire hazard

The surface of the device can become hot with fast-switching actuators or with hot media.

- ▶ Wear suitable protective gloves.
- ▶ Keep highly flammable substances and media away from the device.

3 Product description

The device is used for ultimate precision in the feedback control of medium.

This document describes following variant:

- MDC Industrial Ethernet with an on/off valve
- MDC Industrial Ethernet with an interface for a modular actuator
- MDC büS/CANopen with an on/off valve
- MDC büS/CANopen with an interface for a modular actuator

3.1 Product overview

MDC büS/ CANopen

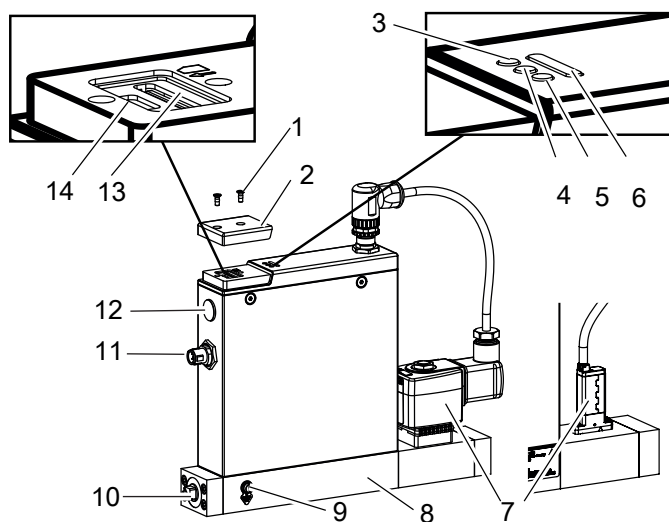

Fig. 1: Example of a variant MDC

1 Screw	2 Cover
3 Not used	4 Not used
5 Not used	6 Status indicator
7 Actuator	8 Base block
9 Functional earth connection	10 Medium connection
11 Electrical connection	12 Not used
13 Slot for memory card	14 büS interface

MDC Industrial Ethernet

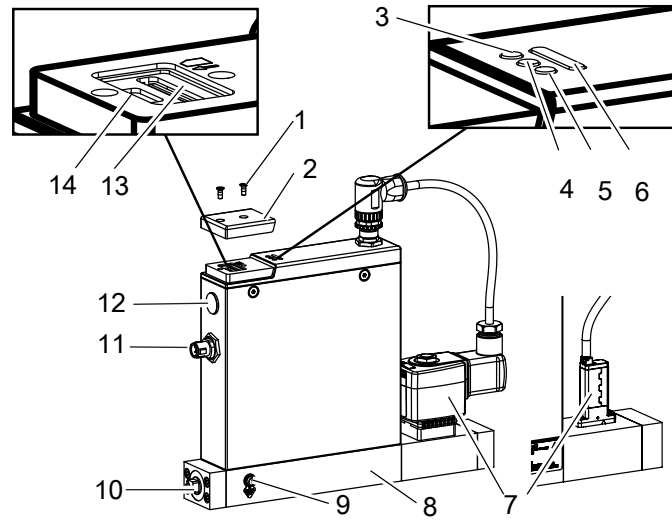

Fig. 2: Example of a variant MDC

1 Screw	2 Cover
3 Status indicator - ETH port 1	4 Communication indicator
5 Status indicator - ETH port 2	6 Status indicator
7 Actuator	8 Base block
9 Functional earth connection	10 Medium connection
11 Electrical connection	12 Electrical connection - 2 x M8
13 Slot for memory card	14 bus interface

3.2 Product identification

3.2.1 Type label

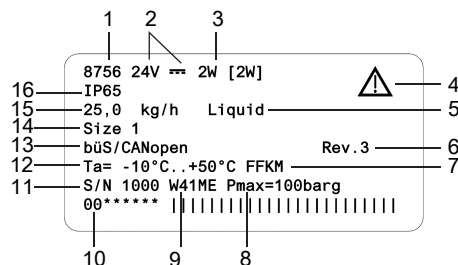

Fig. 3: Example of type label Type 8756

1 Type	2 Operating voltage
3 Power consumption	4 Note: Observe the operating instructions
5 Calibration medium	6 Bürkert internal version
7 Sealing material	8 Maximum operating pressure
9 Manufacture code	10 Article number
11 Serial number	12 Ambient temperature
13 Protocol	14 Size of the sensor
15 Nominal mass flow rate (Q nominal)	16 Degree of protection

3.2.2 Calibration label

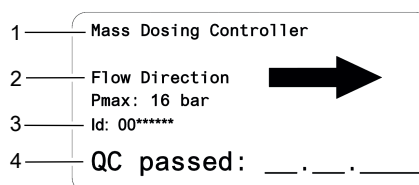

Fig. 4: Example of calibration label

1 Variant	2 Flow direction
3 Article number	4 Manufacturing date

3.2.3 Conformity marking

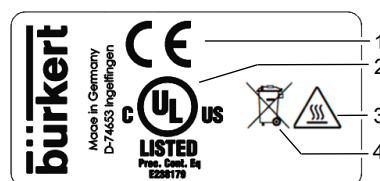

Fig. 5: Conformity label

1 CE marking	2 Certification marking for USA and/or Canada
3 Warning: hot surface	4 Indication for disposal

3.2.4 Symbols and markings on device



Earth terminal



Direct current

Industrial Ethernet variant

DC-B0-58-FF-FF-
FF

Example of marking of the MAC address

ETH1, ETH2

Ethernet connections

3.3 Display elements

3.3.1 Status indicator

The status indicator changes its colour based on the NAMUR recommendation NE 107. Refer to [NAMUR mode \[▶ 14\]](#).

The colour of the status indicator indicates:

- Whether device diagnostics are active or not. Diagnostics are active on the device and cannot be deactivated.
- If diagnostics are active, then the status indicator shows whether diagnostics events have been generated or not. If several diagnostics events have been generated, then the status indicator shows the diagnostics event with the highest priority.

If the status indicator flashes, then the device is selected in a man-machine interface such as the Bürkert Communicator software.

- ▶ To solve a problem indicated by the status indicator, refer to [Troubleshooting \[▶ 55\]](#)

3.3.2 NAMUR mode

The status indicator shows the status of the device and its peripherals, based on NAMUR recommendation 107 (NR 107).

If various alerts are present, the status indicator always shines in the colour of the highest prioritised alert (red = outage = highest priority).

Colour	Colour code	Status	Description
red	5	Failure, error or fault	Due to a malfunction in the device or its periphery, normal operation is not possible.
orange	4	Function check	Work is being carried out on the device, which means that normal operation is temporarily not possible.
yellow	3	Out of specification	The environment conditions or process conditions for the device are not within the specified range. Internal device diagnostics indicate problems within the device or with the process properties.
blue	2	Maintenance required	The device is in normal operation, although a function is briefly restricted. ▶ Service device
green	1	Diagnostics active	Device is running faultlessly, diagnostics are active.
white	0	Diagnostics inactive	Device is switched on, diagnostics are inactive.

Tab. 1: Status indicator according to NE 107

3.3.3 Network status indicator

Applicable for: • Industrial Ethernet variant

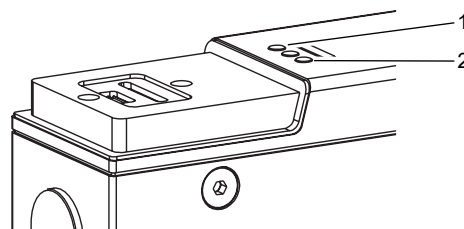

Fig. 6: Location and description of the LED's

1 Ethernet Port 1

2 Ethernet Port 2

3.3.4 Communication indicator

Applicable for: • Industrial Ethernet variant

This LED shows the status of the communication between the device and the PLC (Programmable Logical Controller).

LED indicator	Description	Meaning
Green	RUN	Connection to the PLC is active.
Red	ERROR	Connection to the PLC is inactive.

Tab. 2: Description of the communication indicator

3.4 Functionality

3.4.1 Service-büS interface

Applicable for: • Industrial Ethernet variant

The Service-büS interface is used for short-term servicing of the device with the Bürkert Communicator.

The Bürkert Communicator runs under Windows. Refer to [Connect to the Bürkert Communicator \[▶ 39\]](#)

The USB-büS-Interface set, available as an accessory, is necessary. Refer to [Spare parts and accessories \[▶ 61\]](#)

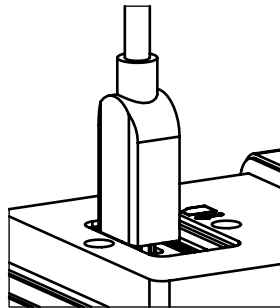

Fig. 7: büS stick, inserted in the related connector of the device

3.4.2 On/Off valve

Applicable for: • MDC with on/off valve

The device is fitted with one of the following on/off valves:

- Type 6013
- Type 6724
- Type 6757

Refer to the Type label of the on/off valve.

3.4.3 Customised actuator

Applicable for: • MDC for modular actuator

The device can be combined to the following actuators:

- a proportional valve
- an on/off valve

When selecting the actuator, observe the following basic data of the device:

- nominal flow rate
- inlet pressure

Refer to [Configure the actuator \[▶ 47\]](#).

3.4.4 Service life of the on/off valve

MDC with on/off valve

The service life of the on/off valve is reached when at least on the following problems occurs:

- the product does not dose correctly any more
- the on/off valve is not tight any more
- the on/off valve does not open any more

If the service life of the on/off valve is reached, then replace the on/off valve with a new one. Refer to chapter [Maintenance](#) [▶ 51].

3.4.5 Memory card



If the memory card is defective or has been lost, contact your Bürkert sales office to purchase a new one.

The device can be delivered with a memory card that is inserted in the device. When the device is energised, there are two possibilities:

- If the inserted memory card contains device-specific data, the device automatically adopts this data. At the time of delivery, the memory card is preloaded with device-specific information. To view the stored data, refer to the file **Device Description File**.
- If the inserted memory card is empty, the device saves its own data onto the card. A new memory card is empty.

The data stored on the memory card can be transferred to another device with the same article number. For example, data from a defective device can be transferred to a replacement device.



To download the file **Device Description File**:

- ▶ Go to <https://products.burkert.com/?type=8756>
- ▶ Scroll down to **Downloads** > **Software**

Applicable for: • büS / CANopen variant

The büS/CANopen variant supports the config-client if no memory card is used.

- ▶ Activate this functionality in the Bürkert communicator under **General settings** > **Parameter** > **Act as a configuration client** > **Yes**.



For detailed information, refer to the "Software manual | Central configuration management" (this manual exists in several languages).

- ▶ Go to <https://products.burkert.com/?type=8756>
- ▶ Scroll down to **Downloads** > **User Manuals**

4 Technical data

4.1 Standards and directives

The device complies with the valid EU harmonisation legislation.

The harmonised standards that have been applied for the conformity assessment procedure are listed in the current version of the EU Declaration of Conformity.

4.2 Operating conditions

MDC with on/off valve Type 6013	
Ambient temperature	-10...+50 °C
Storage temperature	-10...+70 °C
Degree of protection (EN 60529 / IEC 60529)	IP65 ¹⁾
Altitude	Up to 2000 m above sea level
Medium temperature	-10...+60 °C, only in liquid state
Medium	Clean and homogeneous liquids
Operating pressure (inlet pressure)	max. 16 bar
Relative ambient humidity	Max. 95% at 55 °C (non-condensing)
MDC with on/off valve Type 6724	
Ambient temperature	0...+50 °C
Storage temperature	-10...+70 °C
Degree of protection (EN 60529 / IEC 60529)	IP10 ¹⁾
Altitude	Up to 2000 m above sea level
Medium temperature	-10...+50 °C, only in liquid state
Medium	Clean and homogeneous liquids
Operating pressure (inlet pressure)	max. 5 bar
Relative ambient humidity	Max. 95% at 55 °C (non-condensing)

MAN 1000530061 EN Version: G Status: RL (released | freigegeben) printed: 27.02.2025

¹⁾ When cables or plugs and sockets are connected correctly, verified by Bürkert, not evaluated by UL.

MDC with on/off valve Type 6757	
Ambient temperature	0...+50 °C
Storage temperature	-10...+70 °C
Degree of protection (EN 60529 / IEC 60529)	IP30 ¹⁾
Altitude	Up to 2000 m above sea level
Medium temperature	+15...+50 °C, only in liquid state
Medium	Clean and homogeneous liquids
Operating pressure (inlet pressure)	max. 10 bar
Relative ambient humidity	Max. 95% at 55 °C (non-condensing)
MDC for modular actuator	
Ambient temperature	-10...+70 °C
Storage temperature	-10...+70 °C
Degree of protection (EN 60529 / IEC 60529)	IP65 ¹⁾
Altitude	Up to 2000 m above sea level
Medium temperature	-10...+70 °C, only in liquid state
Medium	Clean and homogeneous liquids
Operating pressure	G-internal-threaded FFKM or PCTFE: max. 100 bar Metal: max. 50 bar
Operating pressure	NPT-internal-threaded FFKM or PCTFE: max. 100 bar Metal: max. 50 bar
Operating pressure	External-threaded vacuum fittings max. 50 bar
Operating pressure	External-threaded compression fittings max. 50 bar
Operating pressure	Tri-Clamp max. 25 bar
Relative ambient humidity	Max. 95% at 55 °C (non-condensing)

4.3 Medium data

4.3.1 Calibration conditions

MDC with on/off valve	
Calibration medium	Water
Temperature of the calibration medium	25 °C
Calibration pressure	4 bar

4.3.2 Operating medium

MDC with on/off valve Type 6013	
Maximum particle size	10 µm
Maximum dynamic viscosity	350 mPa.s, with reduced flow-rate range. Take the pressure loss into account. Refer to chapter Pressure loss.

MDC with on/off valve Type 6724, only DN1	
Medium	Clean and homogeneous liquids
Maximum particle size	10 µm
Maximum dynamic viscosity	50 mPa.s, with reduced flow-rate range. Take the pressure loss into account. Refer to chapter Pressure loss.

MDC with on/off valve Type 6757, only DN2	
Medium	Clean and homogeneous liquids
Maximum particle size	10 µm
Maximum dynamic viscosity	40 mPa.s, with reduced flow-rate range. Take the pressure loss into account. Refer to chapter Pressure loss.

4.3.3 Density measurement

MDC with on/off valve	
Density range	0...5 kg/l
Measurement accuracy	±0.01 kg/l (for mass flow rate values higher than 1.5 kg/h)
Repeatability	±0.005 kg/l (for mass flow rate values higher than 1.5 kg/h)

4.3.4 Temperature measurement

MDC with on/off valve	
Temperature range	-10...60 °C
Measurement accuracy	±1.0 K (for mass flow rate values higher than 1.5 kg/h)
Repeatability	±0.5 K (for mass flow rate values higher than 1.5 kg/h)

4.3.5 Mass flow rate measurement

MDC with on/off valve	
Maximum mass flow rate	DN1: 30 kg/h DN2: 150 kg/h
Minimum measurable mass flow rate	DN1: factory setting 0.05 kg/h (can be reduced to 0.01 kg/h) DN2: factory setting 0.25 kg/h (can be reduced to 0.05 kg/h)
Nominal mass flow rate	DN1: factory setting 30 kg/h (minimum reducible to Q _{nom} = 1 kg/h) DN2: factory setting 150 kg/h (minimum reducible to Q _{nom} = 5 kg/h)
Maximum measurement range	1:3000 The measurement range is defined as the ratio of Q _{nominal} of the device to Q _{min} . Refer to following figure. DN1: Q _{min} = 0.05 kg/h DN2: Q _{min} = 0.25 kg/h

4.3.6 Pressure loss

4.3.7 Dosing volume range

MDC with on/off valve

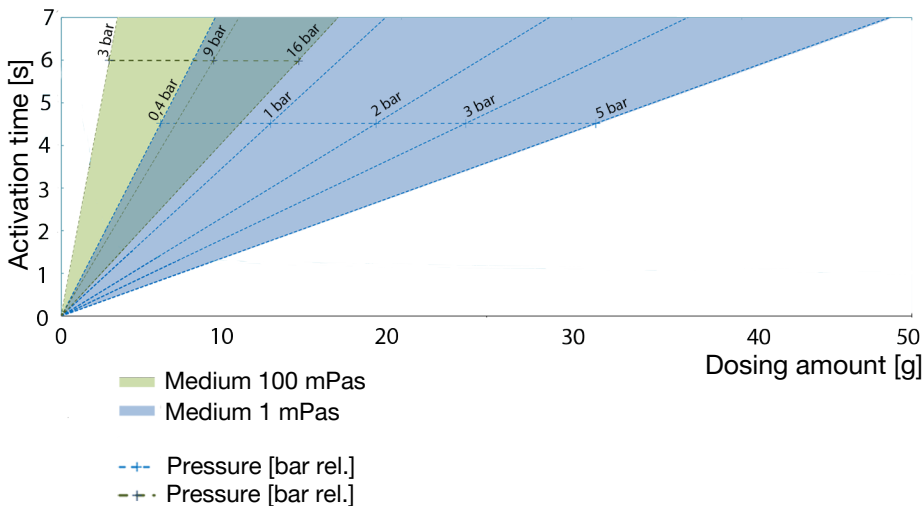

Fig. 8: DN1 variant. Dosing quantity depending on pressure and valve opening time < 50 g

The accuracy is 0,2% of the dosing weight.

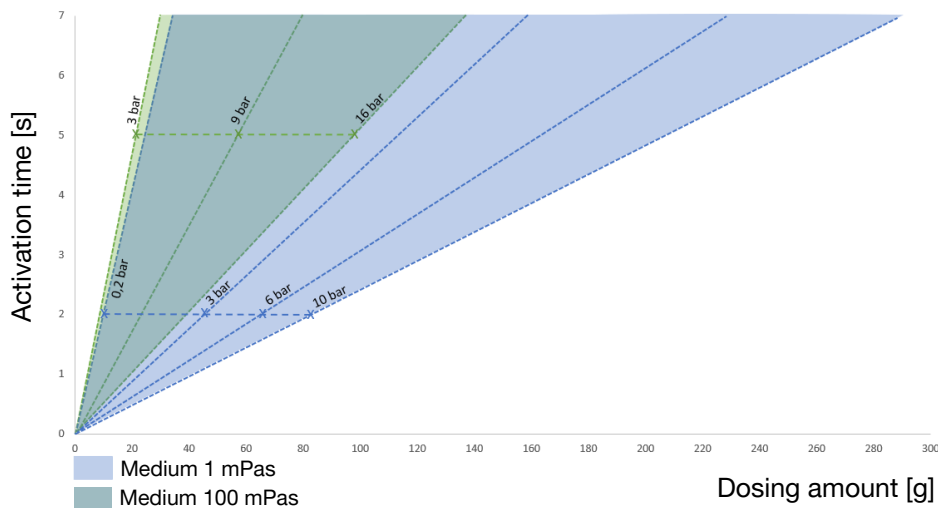

Fig. 9: DN2 variant. Dosing quantity depending on pressure and valve opening time < 300 g

4.4 Electrical data

MDC Industrial Ethernet with on/off valve Type 6013	
Power consumption	< 16 W
Typical power consumption	8 W for water and at a flow rate of 25 kg/h
Communication interface	Industrial Ethernet: PROFINET, EtherNet/IP, EtherCAT, Modbus TCP
Minimum temperature rating of the cable to be connected to the field wiring terminals:	75 °C
MDC büS/CANopen with on/off valve Type 6013	
Operating voltage	24 V \pm 10 % residual ripple < 2 %
Power consumption	< 16 W
Typical power consumption	8 W for water and at a flow rate of 25 kg/h
Communication interface	büS and CANopen. The communication type can be selected with the Bürkert Communicator software.
Electrical connections	M12 plug 5-pin A-coding
Minimum temperature rating of the cable to be connected to the field wiring terminals:	75 °C
MDC Industrial Ethernet with on/off valve Type 6724	
Operating voltage	24 V \pm 10 % residual ripple < 2 %
Power consumption	< 3 W
Typical power consumption	3 W for water and at a flow rate of 25 kg/h
Communication interface	Industrial Ethernet: PROFINET, EtherNet/IP, EtherCAT, Modbus TCP
Electrical connections	<ul style="list-style-type: none"> • M12 plug 5-pin A-coding • 2 M8 socket 4-pin D-coding • service büS interface
Minimum temperature rating of the cable to be connected to the field wiring terminals:	75 °C

MDC büS/CANopen with on/off valve Type 6724

Operating voltage	24 V \pm 10 % residual ripple < 2 %
Power consumption	< 3 W
Typical power consumption	3 W for water and at a flow rate of 25 kg/h
Communication interface	büS and CANopen. The communication type can be selected with the Bürkert Communicator software.
Electrical connections	M12 plug 5-pin A-coding
Minimum temperature rating of the cable to be connected to the field wiring terminals:	75 °C

MDC Industrial Ethernet with on/off valve Type 6757

Operating voltage	24 V \pm 10 % residual ripple < 2 %
Power consumption	< 4,5 W
Typical power consumption	4,5 W for water and at a flow rate of 120 kg/h
Communication interface	Industrial Ethernet: PROFINET, EtherNet/IP, EtherCAT, Modbus TCP
Electrical connections	<ul style="list-style-type: none"> • M12 plug 5-pin A-coding • 2 M8 socket 4-pin D-coding • service büS interface
Minimum temperature rating of the cable to be connected to the field wiring terminals:	75 °C

MDC büS/CANopen with on/off valve Type 6757

Operating voltage	24 V \pm 10 % residual ripple < 2 %
Power consumption	< 4,5 W
Typical power consumption	4,5 W for water and at a flow rate of 120 kg/h
Communication interface	büS and CANopen. The communication type can be selected with the Bürkert Communicator software.
Electrical connections	M12 plug 5-pin A-coding
Minimum temperature rating of the cable to be connected to the field wiring terminals:	75 °C

MAN 1000530061 EN Version: G Status: RL (released | freigegeben) printed: 27.02.2025

MDC Industrial Ethernet for modular actuator	
Operating voltage	24 V \pm 10 %
Power consumption	< 2 W PLUS < 30 W (power consumption of the actuator)
PWM signal (actuator output)	Open collector, 22 k Ω -pull-up resistor and free wheeling diode, both to 24 V
Analog output (actuator output)	0-10 V analog signal
Digital output (actuator output)	5 V digital signal
Communication interface	Industrial Ethernet: PROFINET, EtherNet/IP, EtherCAT, Modbus TCP
Electrical connections	<ul style="list-style-type: none"> • M12 plug 5-pin A-coding • 2 M8 socket 4-pin D-coding • service bÜS interface
Minimum temperature rating of the cable to be connected to the field wiring terminals:	75 °C

MDC bÜS/CANopen for modular actuator	
Operating voltage	24 V \pm 10 %
Power consumption	< 2 W PLUS < 30 W (power consumption of the actuator)
PWM signal (actuator output)	Open collector, 22 k Ω -pull-up resistor and free wheeling diode, both to 24 V
Analog output (actuator output)	0-10 V analog signal
Digital output (actuator output)	5 V digital signal
Communication interface	bÜS and CANopen. The communication type can be selected with the Bürkert Communicator software.
Electrical connections	M12 plug 5-pin A-coding
Minimum temperature rating of the cable to be connected to the field wiring terminals:	75 °C

4.5 Communication

4.5.1 Industrial Ethernet: EtherCAT



Ethernet interface Port 1, Port 2	Port 1: EtherCAT IN Port 2: EtherCAT OUT
Acyclic communication (CoE)	SDO
Type	Complex Slave
FMMUs	8
Sync Managers	4
Transmission speed	100 Mbit/s
Data transport layer	Ethernet II, IEEE 802.3

EtherCAT® is a registered trademark and patented technology, licensed by Beckhoff Automation GmbH, Germany.

4.5.2 Industrial Ethernet: EtherNet/IP

Pre-defined standard objects	Identity Object (0x01) Message Router Object (0x02) Assembly Object (0x04) Connection Manager (0x06) DLR Object (0x47) QoS Object (0x48) TCP/IP Interface Object (0xF5) Ethernet Link Object (0xF6)
DHCP	supported
BOOTP	supported
Transmission speed	10 and 100 Mbit/s
Duplex modes	Half duplex, full duplex, auto-negotiation
MDI modes	MDI, MDI-X, Auto-MDI-X
Data transport layer	Ethernet II, IEEE 802.3
Address Conflict Detection (ACD)	supported
DLR (ring topology)	supported
CIP reset service	Identity Object Reset Service Type 0 and Type 1

4.5.3 Industrial Ethernet: Modbus TCP

Modbus function codes	1, 2, 3, 4, 16
Transmission speed	10 and 100 Mbit/s
Data transport layer	Ethernet II, IEEE 802.3

4.5.4 Industrial Ethernet: PROFINET IO

Topology recognition	LLDP, SNMP V1, MIB2, Physical Device
Minimum cycle time	2 ms
IRT	not supported
MRP media redundancy	MRP client is supported
Other supported functions	DCP, VLAN Priority Tagging, Shared Device
Transmission speed	100 Mbit/s
Data transport layer	Ethernet II, IEEE 802.3
PROFINET IO specification	V2.42
Application Relations (AR)	The device can simultaneously process up to 2 IO ARs, 1 Supervisor AR, and 1 Supervisor DA AR.

4.6 Mechanical data

Dimensions	Refer to data sheet
Base block	Stainless steel 316L
Housing	Painted aluminium, stainless steel
Seal	Refer to the type label
Status indicator	Polycarbonate
Parts in contact with the medium (sensor)	stainless steel 1.4404

MDC with on/off valve Type 6013

Parts in contact with the medium	Stainless steel 1.4305, 1.4113, 1.4310, 1.4303, EPDM
----------------------------------	--

MDC with on/off valve Type 6724

Parts in contact with the medium	EPDM, PEEK
----------------------------------	------------

MDC with on/off valve Type 6757

Parts in contact with the medium	FFKM, PEEK
----------------------------------	------------

5 Medium connection



Risk of injury or material damage when working on the device or system.

- ▶ Read and observe the chapter [Safety \[▶ 8\]](#) before working on the device or system.

5.1 Possible medium connections

MDC

- G-internal-threaded connections according to DIN ISO228/1
- NPT-internal-threaded connections according to ASME/ ANSI B 1.20.1
- connections with external-threaded vacuum fittings
- connections with external-threaded compression fittings

5.2 Installation procedure

NOTICE!

Malfunction that is due to contamination.

- ▶ If a contaminated medium is used, then install a filter upstream of the device. The filter ensures problem-free functioning of the device. Refer to [Medium data \[▶ 20\]](#)

NOTICE!

Cavitation of gas in the liquid and degassing must be avoided.

- ▶ To avoid cavitation and degassing, make sure that the medium is an homogeneous liquid and that the pressure in the pipe is high enough.
- ▶ When installing the device in the pipe, observe the flow direction that is given on the calibration plate of the device.
- ▶ If a external pump is used, then install the pump upstream of the device.

NOTICE!

- ▶ Do not use any pump in the installation because the flow rate must not pulsate.

No inlet section and no outlet section for flow conditioning are required.

MDC with on/off valve Type 6013

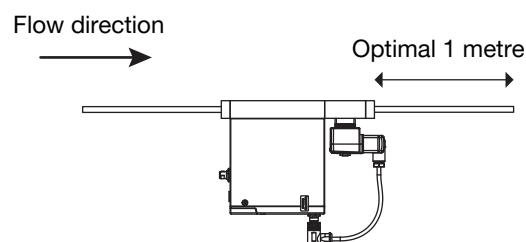

Fig. 10: Mounting position

MDC with on/off valve Type 6724 and type 6757

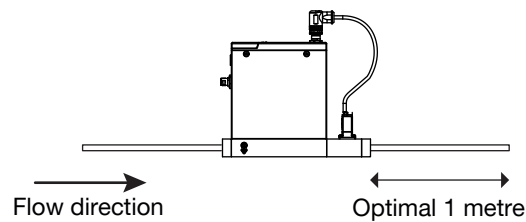

Fig. 11: Mounting position

5.2.1 G1/8"-internal-threaded connections

- ▶ Remove the protective cap that closes the threaded connection.
- ▶ Do the medium connection on one side of the device.
- ▶ Obey the instructions that are given by the manufacturer of the fitting used.
- ▶ Obey the torques that are given by the manufacturer of the fitting used.
- ▶ Do the medium connection on the other side of the device in the same way.

5.2.2 NPT1/8"-internal-threaded connections

- ▶ Do the medium connection on one side of the device.
- ▶ Obey the instructions that are given by the manufacturer of the fitting used.
- ▶ Obey the torques that are given by the manufacturer of the fitting used.
- ▶ Do the medium connection on the other side of the device in the same way.

5.2.3 Connections with external-threaded vacuum fittings

- ▶ Remove the protective cap that closes the connection.
- ▶ Do the medium connection on one side of the device.
- ▶ Obey the instructions that are given by the manufacturer of the fitting used.
- ▶ **CAUTION! To avoid damage on the sealing of the medium connection, please make sure to lock the hexagonal part in place with a second wrench.**
Obey the torques that are given by the manufacturer of the fitting used.
- ▶ Do the medium connection on the other side of the device in the same way.

5.2.4 Connections with external-threaded compression fittings

- ▶ Do the medium connection on one side of the device.
- ▶ Obey the instructions that are given by the manufacturer of the fitting used.
- ▶ **CAUTION! To avoid damage on the sealing of the medium connection, please make sure to lock the hexagonal part in place with a second wrench.**
Obey the torques that are given by the manufacturer of the fitting used.
- ▶ For the variant Alloy C22: screw the fitting in the base block and tighten it to a torque of 20 N·m.
- ▶ Do the medium connection on the other side of the device in the same way.

5.2.5 Tri-clamp connections

- ▶ Remove the protective cap that closes the threaded connection.
- ▶ Do the medium connection on one side of the device.
- ▶ Obey the instructions that are given by the manufacturer of the fitting used.
- ▶ Do the medium connection on the other side of the device in the same way.

6 Electrical connection



Risk of injury or material damage when working on the device or system.

- ▶ Read and observe the chapter [Safety \[▶ 8\]](#) before working on the device or system.

6.1 Additional documentation

- For more information on büS, read the cabling guide that is available at country.burkert.com.
- For more information on CANopen that is related to the device, refer to the Operating Instructions "CANopen Network configuration" at country.burkert.com.
- Device description file and object description for the related Type (download from country.burkert.com).
- Device specific help in the Bürkert Communicator software.
- büS-driver for LabVIEW on request.

6.2 Wire the variant büS /CANopen

NOTICE!

UL approved versions must be supplied in one of the following ways:

- ▶ "Limited Energy Circuit" (LEC), according to UL / IEC61010-1
- ▶ "Limited Power Source" (LPS), according to UL / IEC60950
- ▶ SELV / PELV with UL-approved overcurrent protection, designed according to UL / IEC61010-1, Table 18 (e.g. Block PM-0124-020-0)
- ▶ NEC Class 2 power supply unit

6.2.1 With büS extension cables from Bürkert



Requirements for the correct operation of the device.

- ▶ Refer to the cabling guide at country.burkert.com.

To wire the device, use büS extension cables from Bürkert.

- ▶ Screw the mating female connector to the 5-pin male connector, to the torque given by the manufacturer of the mating female connector.
- ▶ Do the functional earthing of the device. Refer to [Connect the functional earth \[▶ 36\]](#)

6.2.2 With büS cables from Bürkert



Requirements for the correct operation of the device.

- ▶ Refer to the cabling guide at country.burkert.com.

To wire the device, büS cables and mating female connectors are available from Bürkert.

If a büS cable from Bürkert is used, then observe the signals of the conductors.

Colour of the büS cable conductor	Signal
red	24 V \equiv
black	GND
white	CAN_H
blue	CAN_L

Tab. 3: Signals of the büS cable conductors

NOTICE!

If an own mating female connector is used, then observe the following requirements for the correct operation of the device.

- ▶ Use a mating female connector with shield connection.
- ▶ Make sure that the büS cable passes through the mating female connector. The büS cable that is available from Bürkert has an external diameter of 8.2 mm.

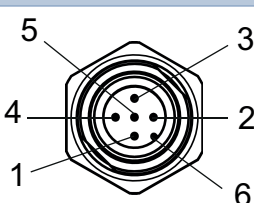
5-pin M12 male connector (A coding)	Pin	Assignment
	1	Shield
	2	24 V \equiv
	3	GND
	4	CAN_H
	5	CAN_L
	6	Coding lug

M12 thread is internally connected to FE

Tab. 4: Pin assignment, 5-pin M12 male connector (A coding) of the device

- ▶ Wire the mating female connector. Observe the instructions that are given by the manufacturer of the mating female connector.
- ▶ Insert each conductor into the appropriate pin.
- ▶ Take a strand of the cable shielding and insert the strand into pin 1.
- ▶ Screw the mating female connector to the 5-pin male connector, to the torque given by the manufacturer of the mating female connector.
- ▶ Do the functional earthing of the device. Refer to [Connect the functional earth \[▶ 36\]](#)

6.2.3 With CANopen cables



Requirements for the correct operation of the device.

- ▶ Use shielded CANopen cables. The cable shielding can be either a braid shielding or a foil shielding.

To wire the device, mating female connectors are available from Bürkert.

NOTICE!

Requirements for the correct operation of the device.

- ▶ Use a mating female connector with shield connection.
- ▶ Observe the specifications for the cable and conductors, that are given by the manufacturer of the mating female connector.

5-pin M12 male connector (A coding)	Pin	Assignment
	1	Shield
	2	24 V \equiv
	3	GND
	4	CAN_H
	5	CAN_L
	6	Coding lug

M12 thread is internally connected to FE

Tab. 5: Pin assignment, 5-pin M12 male connector (A coding) of the device

- ▶ Wire the mating female connector. Observe the instructions that are given by the manufacturer of the mating female connector.
- ▶ Insert each conductor into the appropriate pin.
- ▶ Take a strand of the cable shielding and insert the strand into pin 1.
- ▶ Screw the mating female connector to the 5-pin male connector, to the torque given by the manufacturer of the mating female connector.
- ▶ Do the functional earthing of the device. Refer to [Connect the functional earth \[▶ 36\]](#)

6.3 Wire the variant Industrial Ethernet

NOTICE!

Requirements for the correct operation of the device.

- ▶ Use a power supply unit with sufficient power.
- ▶ Use only Industrial Ethernet shielded cables with a category CAT-5e or higher.
- ▶ Connect each cable end to the functional earth.
- ▶ For an MDC pay attention to the maximum permissible residual ripple on the operating voltage (residual ripple < 2 %).

NOTICE!

UL approved versions must be supplied in one of the following ways:

- ▶ "Limited Energy Circuit" (LEC), according to UL / IEC61010-1
- ▶ "Limited Power Source" (LPS), according to UL / IEC60950
- ▶ SELV / PELV with UL-approved overcurrent protection, designed according to UL / IEC61010-1, Table 18 (e.g. Block PM-0124-020-0)
- ▶ NEC Class 2 power supply unit

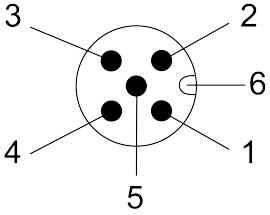
5-pin M12 male connector (A coding)	Pin	Assignment
	1	Shielding
	2	24 V \equiv
	3	GND
	4	Not connected
	5	Not connected
	6	Coding lug

M12 thread is internally connected to FE

Tab. 6: Pin assignment, 5-pin M12 male connector (A coding) of the device

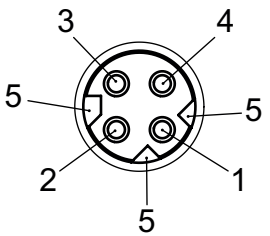
4-pin M8 female connector (D coding)	Pin	Assignment
	1	Tx +
	2	Rx +
	3	Tx -
	4	Rx -
	5	Coding lug

M8 thread is internally connected to FE

Tab. 7: Pin assignment, 4-pin M8 (D coding) of the device

- ▶ If a protocol other than EtherCAT is used, plug an Ethernet cable in one or both sockets.
- ▶ If the EtherCAT protocol is used, plug the incoming Ethernet cable (coming from the PLC) into the socket marked ETH1 and plug the outgoing Ethernet cable into the socket marked ETH2.

6.4 Change the network parameters

Applicable for: • Industrial Ethernet variant



The Industrial Ethernet variants Ethernet/IP and ModbusTCP have the same default IP address 192.168.1.100, Profinet devices have 0.0.0.0 by default.

- ▶ Before commissioning the device, change its network parameters.
- ▶ If several devices must be connected to the same Industrial Ethernet network, then connect one device at a time and change its network parameters.

6.4.1 Over the product web-server

NOTICE!

Security risk due to default passwords.

Unauthorised persons can log in to the web server and change the parameters.

- ▶ Change the default passwords.
- ▶ If the web server is not needed, then disable access with the Bürkert Communicator software, refer to [Configuration with Bürkert Communicator](#) [▶ 39]

Prerequisites:

- The industrial Ethernet variant is not EtherCAT
- Digital device (PC, tablet,...) with a web browser.
- Possibly, a USB-Ethernet adapter.
- ▶ Connect the device to the digital device with an Ethernet cable. Alternatively, it's possible to connect the device to the PC over a USB-Ethernet adapter.
- ▶ Energise the digital device and the device.
- ▶ If the device is connected to the digital device over a USB-Ethernet adapter, then configure the IP address of the USB-Ethernet adapter. Else, configure the IP address of the network card of the digital device.
- ▶ Change the IP address to 192.168.1.xxx, where xxx is different from 100.
- ▶ Open the web browser. In the address bar of the web browser, enter 192.168.1.100.
 - ✓ The home page of the web server opens. Some device data are shown.
- ▶ Open a web server session, to configure the network parameters of the device.
- ▶ If you are not automatically invited to log in, select **Login**.
- ▶ **User name**: enter admin
- ▶ **User password**: enter admin
- ▶ Click **Login**.
- ▶ Change the default passwords with customized passwords.
- ▶ Change the network parameters of the device.
- ▶ Go to **Industrial communication** > **Configuration**.
- ▶ Change the parameters.
- ▶ To save the changes, select **Apply**.
- ▶ To update the parameters, select **Restart**.
- ✓ The device restarts.
- ✓ The network parameters of the device are changed.

6.4.2 Over the Bürkert Communicator software

- ▶ Connect the device to the Bürkert Communicator software. Refer to [Configuration with Bürkert Communicator](#) [▶ 39].
- ▶ Change the network parameters of the device.
- ▶ Go to **Industrial communication** > **Parameter**.

- ▶ Change the parameters.
- ▶ To update the parameters, restart the device.
- ✓ The device restarts.
- ✓ The network parameters of the device are changed.

6.5 Connect the functional earth



WARNING!

Risk of ignition and risk of fire that are due to electrostatic discharge.

An electrostatic discharge of the device can ignite combustible gas vapours.

- ▶ To avoid a build up of electrostatic charge, connect the housing to the functional earth.
- ▶ If the functional earth is not attached, then the requirements of the EMC directive are not met.

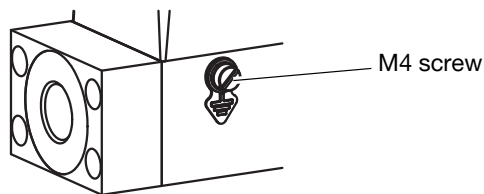

Fig. 12: Location of the M4 screw for the connection of the functional earth

- ▶ Use a green-and-yellow cable that is as short as possible. And the cable cross-section must be at least equal to the cross section of the power-supply cable.
- ▶ With a flat screwdriver of size 6.5 mm, loosen the M4 screw.
- ▶ Attach the green-and-yellow cable to the M4 screw with a cable lug.
- ▶ Tighten the M4 screw to a torque of 1,8 N·m...2 N·m (1,33 lbf·ft...1,47 lbf·ft).

6.6 Connect the external actuator

Applicable for: • MDC for modular actuator

To wire the device, mating male connectors are available from Bürkert.

8-pin M12 female connector	Pin	Assignment
	1	24 V
	2	GND
	3	0-10 V output
	4	0-10 V GND
	5	Digital output (5 V level)
	6 ²⁾	PWM (open collector)
	7	Internal use only
	8	Not connected
	9	Coding lug
	Housing	FE

Tab. 8: Pin assignment, 8-pin M12 female connector

- ▶ Wire the mating male connector according to the pin assignment of the M12 female connector. Observe the instructions that are given by the manufacturer of the mating male connector.
- ▶ Screw the mating male connector to the 8-pin female connector, to the torque given by the manufacturer of the mating male connector.

Refer to [Configure the actuator \[▶ 47\]](#).

6.6.1 Connection examples with Bürkert valves

Valve	Device example	Connection
Proportional valves	Type 2873	Use pin 1 and 6.
On/off valves	Type 6727, 6757, 6013	Use pin 1 and 6.

MAN 1000530061 EN Version: G Status: RL (released | freigegeben) printed: 27.02.2025

²⁾ 22 kΩ-pull-up resistor and free wheeling diode, both to 24 V, active low.

7 Commissioning



Risk of injury or material damage when working on the device or system.

- ▶ Read and observe the chapter [Safety \[▶ 8\]](#) before working on the device or system.

7.1 Commissioning procedure



The operation of the device is tested at the factory with medium. Residual medium can remain in the device.



If the memory card is defective or lost, then buy a new one from your Bürkert sales office.

MDC with on/off valve

- ▶ No zero adjustment is needed.
- ▶ Pressurise the pipes with medium.
- ▶ Make sure that the on/off valve is completely open.
- ▶ Flush the pipes with medium.
- ▶ Vent the pipes completely.
- ▶ Check if the memory card is inserted.
- ▶ Energise the device.
- ▶ Variant büS /CANopen: Choose between CANopen communication and büS communication. Refer to [Set the CANopen communication or the büS communication \[▶ 48\]](#)

MDC for modular actuator

- ▶ No zero adjustment is needed.
- ▶ Pressurise the pipes with medium.
- ▶ Configure the connected actuator. Refer to [Configure the actuator \[▶ 47\]](#)
- ▶ Flush the pipes with medium.
- ▶ Vent the pipes completely.
- ▶ Check if the memory card is inserted.
- ▶ Energise the device.
- ▶ Variant büS /CANopen: Choose between CANopen communication and büS communication. Refer to [Set the CANopen communication or the büS communication \[▶ 48\]](#)

8 Configuration with Bürkert Communicator

8.1 Setting tools



The MassFlowCommunicator is another PC software that is not compatible with the device. The MassFlowCommunicator software cannot be used to configure or operate the device.

Settings can be made with the Type 8920 Bürkert Communicator.

- ▶ Connect the device to the Bürkert Communicator. Refer to [Connect to the Bürkert Communicator \[▶ 39\]](#)
- ▶ For general information about the Bürkert Communicator, refer to the Type 8920 operating instructions.

8.2 Connect to the Bürkert Communicator

Applicable for: • Industrial Ethernet variant

- ▶ Use the USB-büS-Interface set with article number 00772551.
- ▶ Download the latest version of the Type 8920 Bürkert Communicator from country.burkert.com.
- ▶ Install the Bürkert Communicator on a PC. During installation, the büS stick must not be inserted at the PC.
- ▶ Assemble the parts of the USB-büS-Interface set.



Fig. 13: Assembled parts of the USB-büS-Interface set

- ▶ Set the termination-resistance switch of the büS stick to ON.
- ▶ Insert the büS stick into a USB port of the PC.
- ▶ Energise the device. Refer to [Electrical connection \[▶ 31\]](#)
- ▶ Insert the micro-USB connector into the büS interface for the Bürkert Communicator.
- ▶ Wait until the driver of the büS stick has been completely installed on the PC.
- ▶ Start the Bürkert Communicator.



- ▶ Click on  in the Bürkert Communicator to establish the communication with the device.
 - ✓ A window opens.
- ▶ Select **Connect via USB (büS Stick)**.

- ▶ Select the port **Bürkert USB büS stick**, click on **Finish** and wait until the device symbol appears in the list of devices.
- ▶ In the navigation area, click on the symbol related to the device: The device menu appears.

Applicable for: • büS / CANopen variant

- ▶ Use the USB-büS-Interface set with article number 00772426.



Fig. 14: USB-büS-Interface set

- ▶ Download the latest version of the Type 8920 Bürkert Communicator from country.burkert.com.
- ▶ Install the Bürkert Communicator on a PC. During installation, the büS stick must not be inserted at the PC.

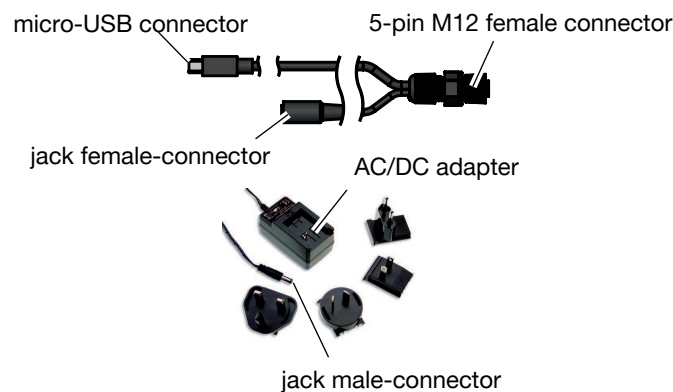



Fig. 15: Electrical connection parts of the USB-büS-Interface set

- ▶ Insert the micro-USB plug into the büS stick.
- ▶ Insert the appropriate power adapter into the AC/DC adapter.
- ▶ Connect the jack male-connector of the AC/DC-adapter cable to the jack female-connector of the M12 female-connector cable.
- ▶ Connect the M12 female connector to the büS network.
- ▶ If the device is connected to a büS network and is at a büS end, then set the büS stick switch to "ON". The termination resistance that is integrated in the büS stick is then activated.
- ▶ Insert the büS stick into a USB port of the PC.
- ▶ Wait until the Windows pilot of the büS stick has been completely installed on the PC.
- ▶ Connect the AC/DC adapter to the power supply.
- ▶ Start the Bürkert Communicator.

- ▶ Click on  in the Bürkert Communicator to establish the communication with the device.

✓ A window opens.

- ▶ Select **Connect via USB (büs Stick)**.
- ▶ Select the port **Bürkert USB büS stick**, click on **Finish** and wait until the device symbol appears in the list of devices.
- ▶ In the navigation area, click on the symbol related to the device: The device menu appears.

8.3 Dosing types

8.3.1 Quantity based dosing

- ▶ Connect the device to the Bürkert Communicator software. Refer to [Connect to the Bürkert Communicator \[▶ 39\]](#)
 - ▶ Select the device.
 - ▶ Go to **Controller** > **Parameter**
 - ▶ Set the quantity to dose: **Setpoint dosing quantity**
Enter the quantity to be dosed.
 - ▶ Set the number of dosings that are performed in a row when the dosing function is started: **Number of doses**
Enter the number of dosings.
 - ▶ If at least 2 dosings are performed in a row, then set the pause time between 2 dosings: **Time delay between doses**
Enter the pause time.
- ✓ The quantity based dosing can be started. Refer to [Start the dosings \[▶ 41\]](#)

8.3.2 Start the dosings

- ▶ Connect the device to the Bürkert Communicator software. Refer to [Connect to the Bürkert Communicator \[▶ 39\]](#)
 - ▶ Select the device.
 - ▶ Start the dosings:
Go to **Controller** > **Parameter** > **Start batch**
Enter 1.
- ✓ The device starts to dose. If the number of dosings to be performed in a row is higher than 1, then the menu item **Dose counter** gives the number of performed dosings.
- ✓ When the set number of dosings is completed, the value in the menu item **Start batch** changes to 0.



A second possibility is to start a dosing over the PDO, for example by a PLC.

8.3.3 Cyclic data (PDOs)

The device receives or transmits following cyclic data:

PDO number	Meaning
1	Start dosing

Tab. 9: Cyclic data received

PDO number	Meaning
1	Last dose time Refer to PDO1, Last dose time [▶ 42]
2	Dosing status Refer to PDO2, Dosing status [▶ 43] Dosing information Refer to PDO2, Dosing information [▶ 43] Quantity last dose (in kg) Refer to PDO2, Quantity last dose [▶ 43]
3	NAMUR status Refer to Status indicator [▶ 14] Error ID Refer to PDO3, Error ID [▶ 43] Medium temperature (in K)

Tab. 10: Cyclic data transmitted

The transmission speed of the PDOs can be changed. Refer to [Transmission speeds of cyclic data \[▶ 49\]](#)

8.3.3.1 PDO1, Last dose time

The value of PDO1 is the sum of the valve opening time and the device balancing time. The balancing time is the time that is needed by the device to detect when the mass flow rate is equal to zero.

8.3.3.2 PDO2, Dosing status

Bit	Designation	Meaning
0	Init	The device is being initialized.
1	Ready	The device is ready to dose and is waiting for the command to start a dose.
2	Dosing in progress	The device is dosing.
3	Ready with initial activation time	The device is ready to dose and is waiting for the command to start a dose. To perform the first dosing, the device uses the initial activation time.
4	In progress with initial activation time	The device is dosing and uses the initial activation time.
5	No trigger accepted	<p>The device is not ready to dose and cannot receive any start command.</p> <p>The device cannot receive any start command in the following situations:</p> <ul style="list-style-type: none"> • the actuator override function is used. Set actuator override to Automatic. • an error has been generated (red or orange) • the device is being initialized.

8.3.3.3 PDO2, Dosing information

The dosing information makes it possible to know whether a dosing has been performed successfully or not.

Bit	Designation	Meaning
0	Maximum activation time is reached	The maximum activation time during a dosing is reached.
1	Maximum balancing time is reached	The maximum balancing time after a dosing is reached.

8.3.3.4 PDO2, Quantity last dose

If large fluctuations occur in the dosed quantities, then remove possible environmental disturbances and make sure the device is installed correctly.

8.3.3.5 PDO3, Error ID

Refer to [Troubleshooting \[► 55\]](#)

Bit	Event	Status indicator
0	Voltage warning The supply voltage is outside the specification. ▶ Operate the device within the specifications.	yellow
1	Voltage error The supply voltage is outside the specification. ▶ Operate the device within the specifications.	red
2	Device temperature warning The device temperature is outside the specification. ▶ Operate the device within the specifications.	yellow
3	Memory error A device memory is defective. ▶ A maintenance operation is needed. Contact the manufacturer.	red
4	Sensor error The device sensor is defective. ▶ A maintenance operation is needed. Contact the manufacturer.	red
5	Flow-rate sensor: calibration curve temporarily repaired The calibration curve is defective and has been repaired. ▶ A maintenance operation is needed. Contact the manufacturer.	blue
6	Fluid temperature outside specification The fluid temperature is outside the specification. ▶ Operate the device within the specifications.	yellow
7	Flow-rate sensor: switch on / initialize The device sensor is being initialized. ▶ Wait until the sensor is initialized. ▶ If the initialization fails (this results in an error bit 4), restart the device. ▶ If it still fails, contact the manufacturer.	yellow
8	Bubbles in the device The device has detected bubbles in the liquid. ▶ Flush bubbles from the pipe. refer to Flush bubbles from the pipe [▶ 46]	yellow
9	Empty pipe detected The device has detected that the pipe is empty. ▶ Fill the pipe with fluid. Make sure that the fluid flows.	yellow
10	Zero-point adjustment in progress A procedure to adjust the zero-point is performed on the device. ▶ Wait until the procedure is finished. ▶ if zero-point adjustment failed, try it again with stable conditions.	orange

Bit	Event	Status indicator
11	Override actuator	orange
	<p>The closed-control loop is deactivated. A direct signal is sent to the actuator.</p> <ul style="list-style-type: none"> ▶ Deactivate the direct control of the actuator. Actuator > Actuator override > Automatic 	
12	Reserved	
13	Unexpected flow detected	yellow
	<p>The device has detected an unexpected flow.</p> <ul style="list-style-type: none"> ▶ Replace the on/off valve. Refer to Maintenance [▶ 51] 	
14...17	Reserved	
18	Actuator warning interval reached	Color stays the same
	<p>The set warning interval for the switching cycles for the on/off valve has been reached. Check the quality of the dosings to see, if the valve must be replaced. Refer to Maintenance [▶ 51]</p>	
19	Actuator maintenance interval reached	blue
	<p>The set maintenance interval for the switching cycles for the on/off valve has been reached. Check the quality of the dosings to see, if the valve must be replaced. Refer to Maintenance [▶ 51]</p>	
20	Unknown error	red
	<p>The device has generated an unknown error.</p> <ul style="list-style-type: none"> ▶ A maintenance operation is needed. Contact the manufacturer. 	
21	Communication message	depends on the event gravity
	<p>Event is only possible when the device uses a gateway. The device has generated a communication message.</p> <ul style="list-style-type: none"> ▶ Check the gateway configuration. 	
22...30	Reserved	
31	Device not available	red
	<p>The device is not available.</p> <ul style="list-style-type: none"> ▶ Check the wiring of the installation. 	

MAN 1000530061 EN Version: G Status: RL (released | freigegeben) printed: 27.02.2025

8.4 Functions

8.4.1 Bubble detection

The device detects when there are bubbles in the liquid.

If there are bubbles in the liquid, then there is a warning with the following means:

- The status indicator is yellow.
- An out-of-specification event is generated.

8.4.2 Flush bubbles from the pipe

To make sure that there are no bubbles in the pipe, do the following procedure:

MDC with on/off valve

- ▶ Make sure that the device is filled with fluid.
- ▶ Connect the device to the Bürkert Communicator software. Refer to [Connect to the Bürkert Communicator \[▶ 39\]](#)
- ▶ Select the device.



WARNING!

Risk of injury from flowing fluid.

While the procedure is running, the mass flow rate value can be higher than the nominal flow rate value.

- ▶ Before running the procedure, make sure that no danger can occur if the mass flow rate value increases.

- ✓ The status indicator is orange.
- ✓ A check-function event is generated.
- ▶ Go to **Actuator** > **Actuator override** > **Open**
- ▶ Flush the pipe until no more air bubbles are visible.
- ▶ If the device still detects bubbles in the pipe, then contact Bürkert.
- ▶ Go to **Actuator** > **Actuator override** > **Automatic**

8.4.3 Unexpected flow detection

If the on/off valve is closed but the device detects that the medium still flows, then the device generates an out-of-specification event.

The function is active by default.

To make sure that the function is active, do the following procedure:

- ▶ Connect the device to the Bürkert Communicator software. Refer to [Connect to the Bürkert Communicator \[▶ 39\]](#)
- ▶ Select the device.
- ▶ Go to **Controller** > **Parameter** > **Use unexpected flow detection** > **Yes**
- ✓ The unexpected flow detection is active.

8.4.4 Detect the end of dosings

The device is able to detect automatically when the mass flow rate is equal to zero after the valve is closed. The detection time is called balancing time.

As an alternative to the automatic detection, it's possible to set a fixed balancing time after which the device considers that the dosing is finished.

The dosed quantity is transmitted at the end of the balancing time.

To activate the automatic detection of a null flow rate, do the following procedure:

- ▶ Connect the device to the Bürkert Communicator software. Refer to [Connect to the Bürkert Communicator \[▶ 39\]](#)
- ▶ Select the device.
- ▶ Go to **Controller** > **Parameter** > **Use balancing time autom. detection** > **Yes**
- ✓ The device automatically detects when the flow rate is null.
- ✓ If the device detects a non-null flow rate after the maximum balancing time has elapsed, then the device generates an error event.

To set a fixed balancing time, do the following procedure:

- ▶ Connect the device to the Bürkert Communicator software. Refer to [Connect to the Bürkert Communicator \[▶ 39\]](#)
- ▶ Select the device.
- ▶ Go to **Controller** > **Parameter** > **Use balancing time autom. detection** > **No**
- ▶ **Balancing time**
- ▶ Enter a duration.
- ✓ The device waits the end of the balancing time to consider that the dosing is finished.
- ✓ If the device detects a non-null flow rate after the set balancing time has elapsed, then the device generates an error event.

8.4.5 Configure the actuator

MDC for modular actuator

- ▶ Connect the device to the Bürkert Communicator software. Refer to [Connect to the Bürkert Communicator \[▶ 39\]](#)
- ▶ Select the device.
- ▶ Go to **Actuator** > **Parameter** > **Start-Up Wizard**
 - ✓ The status indicator is orange.
 - ✓ A check-function event is generated.
- ▶ Follow the instructions of the displayed wizard.

8.4.6 Configure the controller

- ▶ Connect the device to the Bürkert Communicator software. Refer to [Connect to the Bürkert Communicator \[▶ 39\]](#)
- ▶ Select the device.
- ▶ Go to **Controller** > **Parameter** > **Start-Up Wizard**
 - ✓ The status indicator is orange.
 - ✓ A check-function event is generated.

- ▶ Follow the instructions of the displayed wizard.

8.4.7 Monitor the actuator switching cycles

Is used to inform via message, that the actuator maintenance is required. Check for the quality of the dosings.

- ▶ Connect the device to the Bürkert Communicator software. Refer to [Connect to the Bürkert Communicator \[▶ 39\]](#)
- ▶ Select the device.
- ▶ Go to **Actuator** > **Diagnostics** > **Switching cycles monitoring**
- ▶ Activate the monitoring via **Enable monitoring** > **Yes** > **Maintenance interval**
- ▶ Select the number of switching cycles until maintenance is required.
- ✓ At this set number, the device will generate a maintenance message. Refer to error id 19 in [PDO3, Error ID \[▶ 43\]](#).
- ✓ At 80% of this set number the device generates a warning message. Refer to error id 18 in [PDO3, Error ID \[▶ 43\]](#).

8.4.8 Reset the maintenance interval

To reset the maintenance interval, if a valve was replaced, do the following:

- ▶ Connect the device to the Bürkert Communicator software. Refer to [Connect to the Bürkert Communicator \[▶ 39\]](#)
- ▶ Select the device.
- ▶ Go to **Actuator** > **Diagnostics** > **Switching cycles monitoring** > **Reset maintenance interval**

It's also possible to postpone the maintenance message and acknowledge the Error-ID bit by selecting **Postpone maintenance**. This has to be done after every restart of the device.

It's also possible to postpone the warning message by selecting **Postpone warning** to acknowledge the message and Error-ID bit. This has to be done after every restart of the device.

8.5 Set the CANopen communication or the bÜS communication

Applicable for: • bÜS / CANopen variant

To set the operating mode of the digital communication, do the following:

- ▶ Connect the device to the Bürkert Communicator software. Refer to [Connect to the Bürkert Communicator \[▶ 39\]](#)
- ▶ Select the device.
- ▶ Go to **General settings** > **Parameters** > **bÜS** > **Advanced** > **Bus mode**
- ▶ Select the operating mode of the digital communication.
- ▶ Restart the device.
- ✓ The operating mode of the fieldbus is changed.

- ✓ If the operating mode of the fieldbus is bÜS, then the **CANopen status** is set to **Operational** and the PDOs are sent to bÜS.
- ✓ If the operating mode of the fieldbus is CANopen, then the **CANopen status** is set to **Pre-Op** until the CANopen network master switches the device to **Operational**.

8.6 Transmission speeds of cyclic data

The device transmits cyclic data at the following transmission speeds:

- once every 500 ms by default if the value of a PDO is constant. The transmission speed of each PDO can be changed. Refer to [Change the transmission speed of a single PDO \[► 49\]](#)
- once every 100 ms by default if the value of a PDO changes. If the bus load does not exceed 50%, then the transmission speed can be increased temporarily to 10 ms. Refer to [Temporarily increase the transmission speed of all PDOs \[► 49\]](#)

8.6.1 Change the transmission speed of a single PDO

- ▶ Connect the device to the Bürkert Communicator software. Refer to [Connect to the Bürkert Communicator \[► 39\]](#)
- ▶ Select the device.
- ▶ Go to **General settings > Parameters > PDO Configuration**
- ▶ Set the value of the **Inhibit time** for each PDO.
- ✓ The transmission speed of the PDO is changed.

8.6.2 Temporarily increase the transmission speed of all PDOs

If the transmission speed is increased simultaneously on several devices in the network, then make sure that the bus load does not exceed 50%.

- ▶ Energise the bus network.
- ▶ Connect the device to the Bürkert Communicator software. Refer to [Connect to the Bürkert Communicator \[► 39\]](#)
- ▶ Move the PC mouse over the bÜS-stick symbol in the list of devices:
 - If the bus load is higher than 45%, then do not increase the transmission speed.
 - If the bus load is less than or equal to 45%, then the transmission speed can be increased. Do the following procedure:
- ▶ Select the device.
- ▶ Go to **General settings > Diagnostics > Inhibit time**.
- ▶ To increase the transmission speed, click **Set diagnostic mode**. The function **Inhibit time** switches to **Set to default values**.
- ✓ The transmission speed of all the PDOs is increased.
- ▶ To go back to the default transmission speed, click **Set to default values**. The function **Inhibit time** switches to **Set diagnostic mode**.

8.7 Changing between bÜS and CANopen mode

Applicable for: • bÜS / CANopen variant

To select the different digital communication modes (bÜS or CANopen), use the software Bürkert communicator.

- ▶ Connect the device to the Bürkert Communicator software. Refer to [Connect to the Bürkert Communicator \[▶ 39\]](#)
 - ▶ Select the device.
 - ▶ Go to **General settings** > **Parameter** > **bÜS** > **Advanced** > **Bus mode**
 - ▶ Select the operating mode of the digital communication.
 - ▶ Restart the device.
- ✓ The operating mode of the fieldbus is changed.
 - ✓ If the operating mode of the fieldbus is bÜS, the **CANopen status** is set to **Operational** and the PDO's are sent to bÜS.
 - ✓ If the operating mode of the fieldbus is CANopen, the **CANopen status** is set to **Pre-Op** until the CANopen network master switches the device to **Operational**.

9 Maintenance

If the device is operated according to the Operating instructions, then the device is maintenance-free.



Risk of injury or material damage when working on the device or system.

- ▶ Read and observe the chapter [Safety \[▶ 8\]](#) before working on the device or system.

9.1 Replace the memory card

- ▶ De-energise the device.
- ▶ With a TX8 screwdriver loosen the screws of the cover. Remove the cover.

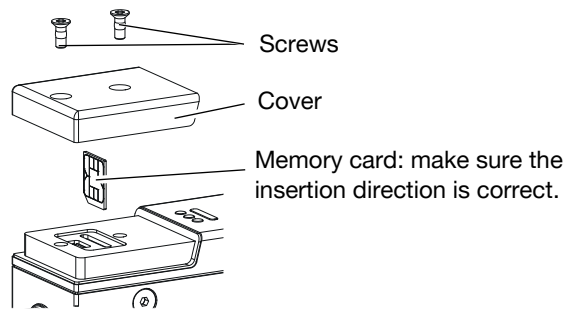

Fig. 16: Insertion direction of the memory card

- ▶ Remove the old memory card from its slot.
- ▶ Pay attention to the insertion direction of the memory card.

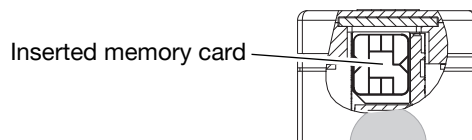

Fig. 17: Cross-sectional drawing

- ▶ With a TX8 screwdriver, screw the cover to a torque of 1.2 N·m (0.9 lbf·ft).
- ▶ Restart the device to write the data on the new memory card. Possible problems related to the memory card are given in [Troubleshooting \[▶ 55\]](#)

Applicable for: • büS / CANopen variant

The büS/CANopen variant supports the config-client if no memory card is used.

- ▶ Activate this functionality in the Bürkert communicator under **General settings** > **Parameter** > **Act as a configuration client** > **Yes**.



For detailed information, refer to the "Software manual | Central configuration management" (this manual exists in several languages).

- ▶ Go to <https://products.burkert.com/?type=8756>
- ▶ Scroll down to **Downloads** > **User Manuals**

9.2 Replace the on/off valve Type 6013

Prepare the device for the replacement of the on/off valve:

- ▶ Flush the device.
- ▶ Relieve the flushing fluid pressure in the installation.
- ▶ De-energise the device.
- ▶ Relieve the operating fluid pressure in the installation.

With a Phillips screwdriver, loosen the screw of the female connector and remove the female connector from the coil.

Dismantle the old valve from the device:

- ▶ With an SW14 open-end spanner, loosen the nut and remove the coil.
- ▶ Remove the plastic cover.
- ▶ Loosen the 2 screws with a TX10 screwdriver.
- ▶ Remove the fluid housing.

Mount the new valve:

- ▶ Make sure that the base block is free of dirt.
- ▶ Make sure that the seal is correctly inserted.
- ▶ Put the fluid housing on the base block. Turn the embossing A towards the device.

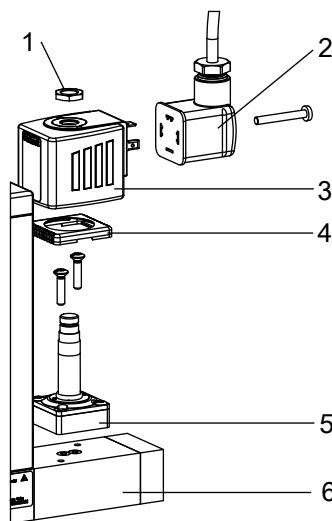

Fig. 18: Mount an on/off valve Type 6013

1 Nut	2 Female connector
3 Coil	4 Plastic cover
5 Fluid housing	6 Base block

- ▶ With a TX10 screwdriver, tighten the screws to a torque of 1.4...1.5 N·m (1.03...1.11 lbf.ft).
- ▶ Put on the plastic cover.
- ▶ Turn the coil so that the electrical connection does not face the device housing.
- ▶ To fix the coil, tighten the nut to a torque of 2.7...2.9 N·m (1.99...2.14 lbf.ft).
- ▶ Plug the female connector on the coil.

- ▶ With a Phillips screwdriver, tighten the connector a torque of max. 1 N·m (0.728 lbf.ft).

9.3 Replace the on/off valve Type 6724

Prepare the device for the replacement of the on/off valve:

- ▶ Flush the device.
- ▶ Relieve the flushing fluid pressure in the installation.
- ▶ De-energise the device.
- ▶ Relieve the operating fluid pressure in the installation.

Unplug by hand the electrical cable from the on/off valve.

Dismantle the old valve from the device:

- ▶ With an hexagon key of size 1.5 mm, loosen the 2 screws of the valve and remove the valve.

Mount the new valve:

- ▶ Make sure that the base block is free of dirt.
- ▶ Make sure that the seal is correctly inserted.

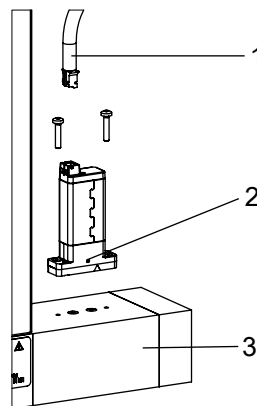

Fig. 19: Mount an on/off valve Type 6724

1 Cable	2 "NC" marking
3 Base block	

- ▶ Turn the valve so that the "NC" marking is close to the device housing. Put the valve on the base block.
- ▶ Tighten the screws to a torque of 0.2...0.25 N·m (0.15...0.18 lbf.ft).

Plug the electrical cable to the on/off valve.

9.4 Replace the on/off valve Type 6757

Prepare the device for the replacement of the on/off valve:

- ▶ Flush the device.
- ▶ Relieve the flushing fluid pressure in the installation.
- ▶ De-energise the device.
- ▶ Relieve the operating fluid pressure in the installation.

Unplug by hand the electrical cable from the on/off valve.

Dismantle the old valve from the device:

- ▶ With an hexagon key of size 2.5 mm, loosen the 2 screws of the valve and remove the valve.

Mount the new valve:

- ▶ Make sure that the base block is free of dirt.
- ▶ Make sure that the seal is correctly inserted.

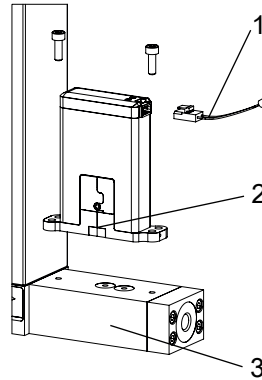

Fig. 20: Mount an on/off valve Type 6757

1 Cable

2 "NC" marking

3 Base block

- ▶ Turn the valve so that the "NC" marking is close to the device housing. Put the valve on the base block.
- ▶ Tighten the screws to a torque of 2,7...2,9 N·m.

Plug the electrical cable to the on/off valve.

10 Troubleshooting

10.1 Problems shown by the PDO3, Error ID

Refer to chapter [PDO3, Error ID \[▶ 43\]](#)

10.2 Status indicator is red

MDC Industrial Ethernet	
The supply voltage is out of the error range. The device can be damaged.	▶ Operate the device within the specifications. If the status indicator is still red, then send the device back to Bürkert.
The sensor, the internal memory or the device is defective.	▶ Contact the manufacturer, because maintenance is needed.
No proper connection to the PLC.	<ul style="list-style-type: none"> ▶ Check the wiring. ▶ Check the status of the PLC. ▶ If the EtherCAT protocol is used, make sure the incoming cable (reception from the PLC) is inserted in the ETH1 port and the outgoing cable is inserted in the ETH2 port.
MDC büS/ CANopen	
The supply voltage is out of the error range. The device can be damaged.	▶ Operate the device within the specifications. If the status indicator is still red, then send the device back to Bürkert.
büS error or CANopen-bus error, for example a short circuit.	▶ Make sure that the device is correctly wired.
The device is connected to büS, but cannot find any fieldbus participants.	<ul style="list-style-type: none"> ▶ Make sure that the device is correctly wired. ▶ Operate the device with other fieldbus participants.
The device is connected to büS, but does not find the process value to be processed.	<ul style="list-style-type: none"> ▶ Make sure that the process value is correctly allocated. ▶ Check the assigned büS participant that is defective. ▶ Make sure that the assigned büS participant provides the cyclic data.
The sensor, the internal memory or the device is defective.	▶ Contact the manufacturer, because maintenance is needed.

10.3 Status indicator is orange

MDC Industrial Ethernet	
A calibration procedure is in progress.	▶ Wait until the calibration procedure is completed.
PROFINET: PLC is in Stop mode	▶ Activate the PLC.

MAN 1000530061 EN Version: G Status: RL (released | freigegeben) printed: 27.02.2025

MDC büS/ CANopen

- | | |
|--|---|
| The device is connected to büS and searches assigned fieldbus participant. | ▶ Wait until the device has found assigned fieldbus participants. |
| The device is connected to büS and is configured manually, but has no address. | ▶ Wait up to one minute until the device assigns its address. |
| A calibration procedure is in progress. | ▶ Wait until the calibration procedure is completed. |

10.4 Status indicator is yellow



The yellow state is displayed for about 15 seconds after electrical power up. The device needs this time to reach the normal operation mode. After this initialisation the device will change to the green state.

MDC Industrial Ethernet

- | | |
|--|---|
| One of the following values is out of specification. The sensor or the device can be damaged. <ul style="list-style-type: none"> • the medium temperature • the device temperature • the supply voltage | ▶ Operate the device within the specifications. If the status indicator is still yellow, then send the device back to Bürkert. |
| The device has detected that the pipe is empty. | ▶ Vent the pipe.
▶ Fill the pipe completely with medium. Refer to Commissioning [▶ 38] |
| The device has detected bubbles in the liquid. | ▶ Flush bubbles from the pipe. Refer to Flush bubbles from the pipe [▶ 46] |
| The set-point position for the actuator has (almost) reached 100%. The set-point value cannot be reached. | ▶ Increase the inlet pressure or decrease the output pressure.
▶ Make sure that the medium viscosity is in the permitted range. Refer to Technical data [▶ 18]
▶ If the pressure drop in the pipe is too high, then reduce the pressure drop.
▶ If the filters that are installed in the pipe are dirty, then clean the filters. |
| A change of the Ethernet protocol is in progress. | ▶ Wait until the change of protocol is completed. It can take up to 1 minute. |

MDC büS/ CANopen

One of the following values is out of specification. The sensor or the device can be damaged.

- the medium temperature
- the device temperature
- the supply voltage

- ▶ Operate the device within the specifications. If the status indicator is still yellow, then send the device back to Bürkert.

The device has detected that the pipe is empty.

- ▶ Vent the pipe.
- ▶ Fill the pipe completely with medium. Refer to [Commissioning \[▶ 38\]](#)

The device has detected bubbles in the liquid.

- ▶ Flush bubbles from the pipe. Refer to [Flush bubbles from the pipe \[▶ 46\]](#)

The set-point position for the actuator has (almost) reached 100%. The set-point value cannot be reached.

- ▶ Increase the inlet pressure or decrease the output pressure.
- ▶ Make sure that the medium viscosity is in the permitted range. Refer to [Technical data \[▶ 18\]](#)
- ▶ If the pressure drop in the pipe is too high, then reduce the pressure drop.
- ▶ If the filters that are installed in the pipe are dirty, then clean the filters.

Other fieldbus participants use the same node ID.

- ▶ Assign an individual node ID to each fieldbus participant.

10.5 Status indicator is blue

Cause	Solution
Error in the internal memory.	▶ Contact the manufacturer, because maintenance is needed.

10.6 Status indicator is off

Cause	Solution
The device is not energised.	<ul style="list-style-type: none"> ▶ Make sure that the device is correctly wired. ▶ Make sure that the voltage supply is 24 V $\overline{=}$. ▶ Make sure that the power supply source is working properly.

10.7 Status indicator flashes

Cause	Solution
The power supply source is not working properly.	<ul style="list-style-type: none"> ▶ Make sure that the power supply source is working properly. ▶ After 10 seconds, the device automatically returns to the previous status.
The device is selected in the Bürkert Communicator.	<ul style="list-style-type: none"> ▶ After max. 10 seconds, the device automatically returns to the previous status.

10.8 Status indicator goes out periodically

Cause	Solution
The power supply is intermittently dropping and the device restarts.	<ul style="list-style-type: none"> ▶ Use a power supply with sufficient power output.
The voltage drop in the connecting cable is too high.	<ul style="list-style-type: none"> ▶ Increase the cross-section of the cable and reduce the cable length.

10.9 Replacement device adopts none of the values from the defective device

Cause	Solution
The article number of the replacement device is different from the article number of the defective device.	<ul style="list-style-type: none"> ▶ Use a replacement device that has the same article number than the defective device. Values can only be transferred between devices with the same article numbers.
The memory card is defective. The device could not write any values to the memory card.	<ul style="list-style-type: none"> ▶ Replace the memory card. Refer to Replace the memory card [▶ 51]

10.10 Replacement device does not adopt all of the values from the defective device

Cause	Solution
The device description of the replacement device is different from the device structure of the defective device. Only the existing values of the defective device can be adopted by the replacement device.	<ul style="list-style-type: none"> ▶ Use the Bürkert Communicator to configure the new values of the replacement device.

10.11 Unstable measured value

MDC	
Functional earth (FE) is not connected properly.	<ul style="list-style-type: none"> ▶ To connect the functional earth, use a green-and-yellow cable that is as short as possible. And the cable cross-section must be at least equal to the cross section of the power-supply cable. Refer to Connect the functional earth [▶ 36]
The residual ripple on the voltage supply is too high.	<ul style="list-style-type: none"> ▶ Use a supply voltage that conforms to the technical data given in Technical data [▶ 18]
The device is caused to vibrate.	<ul style="list-style-type: none"> ▶ Run the Autotune function to adapt to the operating conditions. ▶ Reduce the input pressure or contact the manufacturer.

10.12 Outgassing or bubble formation at the device outlet

MDC for modular actuator	
The pressurized liquid has a high gas solubility or outgassing occurs due to the pressure drop across the control valve.	<ul style="list-style-type: none"> ▶ If possible, reduce the liquid pressure. ▶ Pressurize with a gas that has a lower solubility in the medium. ▶ Pump the unpressurized medium.
MDC with on/off valve	
The pressurized liquid has a high gas solubility or outgassing occurs due to the pressure drop across the on/off valve.	<ul style="list-style-type: none"> ▶ If possible, reduce the liquid pressure. ▶ Pressurize with a gas that has a lower solubility in the medium.

10.13 Dosing quantity cannot be reached

Cause	Solution
The inlet pressure is too low.	<ul style="list-style-type: none"> ▶ Make sure that the pipe diameters and the pipe lengths are adapted. Refer to Dosing volume range [▶ 22] ▶ Increase the inlet pressure.
The on/off valve is not open long enough.	<ul style="list-style-type: none"> ▶ Increase the time during which the on/off valve is open.

10.14 Quantity is not dosed precisely

Cause	Solution
The pressure fluctuates.	▶ Make sure that the pressure is constant.
The fluid is not homogeneous.	▶ Use an homogeneous fluid.
The fluid temperature or the fluid viscosity fluctuates.	▶ Make sure that the fluid temperature and the fluid viscosity are constant.
The time between 2 dosings is too high.	▶ Reduce the time.

10.15 Dripping

Cause	Solution
There are air bubbles in the medium.	▶ Rinse the device.
The inlet pressure is too low.	▶ Increase the inlet pressure.
The fluid viscosity is too high.	▶ Reduce the fluid viscosity.
The diameter of the dosing needle is too high.	▶ Use a dosing needle with an appropriate diameter.
Leakage above the valve.	▶ Replace the valve. Refer to Maintenance [▶ 51]
Wear with a high number of operations.	▶ Replace the valve. Refer to Maintenance [▶ 51]
Particles in the valve seat.	▶ Replace the valve. Refer to Maintenance [▶ 51]

10.16 Network status indicator

LED indicator	Meaning	Action
Link/Act-LED (green) fast blinking	Connection to the parent protocol layer is established.	-
Link/Act-LED (green) slow blinking (directly after restart)	Connection to the protocol layer is searched.	-
Link/Act-LED (green) slow blinking (20 s after restart)	No connection to the parent protocol layer.	▶ Check the cable.
Link/Act-LED (green) is OFF.	No connection to the network.	▶ Check the cable.
Link-LED (yellow) is ON	Connection to the network is established.	-
Link LED (yellow) is not lit	Not connected to network.	▶ Check cable.

Tab. 11: Meaning of the LED indicator

11 Spare parts and accessories



Risk of injury and/or damage due to incorrect parts.

- ▶ Use only original accessories and original spare parts from Bürkert.



Order the parts directly on our [eShop](#).

11.1 Electrical accessories

- ▶ For further accessories, refer to the data sheet.

Industrial Ethernet variant	
USB-büS-interface set, without power supply	772551
Straight 5-pin M12 female connector	772416
Bent 5-pin M12 female connector	772418
Memory card	On request
Connection cable with M12 female connector (A-coded) and free cable end, 5 m	560365
Connection cable with M12 female connector (A-coded) and free cable end, 10 m	563108
Bent 8-pin M12 male connector	775070
büS/CANopen variant	
USB-büS-interface set, including power supply	772426
Straight 5-pin M12 female connector	772416
Bent 5-pin M12 female connector	772418
Y junction	772420
Y junction for connecting 2 separately energised segments of a büS network	772421
5-pin M12 male connector with 120-Ohm termination resistor	772424
5-pin M12 female connector with 120-Ohm termination resistor	772425
Memory card	On request
büS extension cable with 5-pin M12 connectors, 0.1 m	772492
büS extension cable with 5-pin M12 connectors, 0.2 m	772402
büS extension cable with 5-pin M12 connectors, 0.5 m	772403
büS extension cable with 5-pin M12 connectors, 1 m	772404
büS extension cable with 5-pin M12 connectors, 3 m	772405
Bent 8-pin M12 male connector	775070

11.2 Additional software

Bürkert Communicator software	Download from country.burkert.com
büS LabView-driver	Download from country.burkert.com
Variant büS /CANopen and Industrial Ethernet EDS file	Download from country.burkert.com

Tab. 12: Documentation and software

12 Uninstallation

12.1 Dismantling

- ▶ Relieve the medium pressure in the installation.
- ▶ Flush the device with distilled water.
- ▶ Relieve the flushing medium pressure in the installation.
- ▶ De-energise the device.
- ▶ Remove the mating female connectors and the mating male connectors.
- ▶ Disconnect the medium connections.

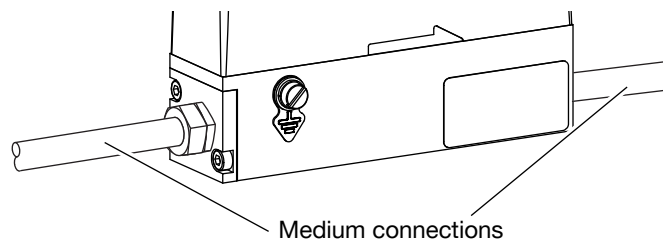

Fig. 21: Medium connections, for example internal-threaded connections

- ▶ Remove the device.

13 Logistics

13.1 Transport and storage

- ▶ Protect the device against moisture and dirt in the original packaging during transportation and storage.
- ▶ Avoid UV radiation and direct sunlight.
- ▶ Protect connections from damage with protective caps.
- ▶ Observe permitted storage temperature.
- ▶ Remove cables, connectors, external filters and installation equipment.
- ▶ Clean and vent contaminated devices.

13.2 Return



No work or tests will be carried out on the device until a valid Contamination Declaration has been received.

- ▶ To return a used device to Bürkert, contact the Bürkert sales office. A return number is required.

13.3 Disposal

Environmentally friendly disposal



- ▶ Follow national regulations regarding disposal and the environment.
- ▶ Collect electrical and electronic devices separately and dispose of them as special waste.

Further information at country.burkert.com