

Type 8745

Mass flow meter / Mass flow controller



Operating Instructions

We reserve the right to make technical changes without notice.

© Bürkert SAS, 2017 - 2024

Operating Instructions 2403/05 00569558 / Original EN

TABLE OF CONTENTS

1	About this document.....	6
1.1	Manufacturer.....	6
1.2	Symbols.....	6
1.3	Terms and abbreviations.....	7
2	Safety.....	8
2.1	Intended use.....	8
2.2	Safety instructions.....	8
3	Product description.....	11
3.1	Product overview.....	11
3.2	Product identification.....	12
3.2.1	Type label.....	12
3.2.2	Calibration label.....	13
3.2.3	Conformity marking.....	13
3.2.4	Symbols and markings on device.....	13
3.3	Display elements.....	13
3.3.1	Status indicator.....	13
3.3.2	NAMUR mode.....	14
3.3.3	Network status indicator.....	15
3.3.4	Communication indicator.....	15
3.4	Functionality.....	15
3.4.1	Service-büs interface.....	15
3.4.2	Actuator is a control valve.....	16
3.4.3	Memory card.....	16
4	Technical data.....	17
4.1	Standards and directives.....	17
4.2	Operating conditions.....	17
4.3	Medium data.....	18
4.4	Electrical data.....	20
4.5	Mechanical data.....	22
4.6	Communication.....	23
4.6.1	Industrial Ethernet: EtherCAT.....	23
4.6.2	Industrial Ethernet: EtherNet/IP.....	23
4.6.3	Industrial Ethernet: Modbus TCP.....	24
4.6.4	Industrial Ethernet: PROFINET IO.....	24
5	Medium connection.....	25
5.1	Possible medium connections.....	25
5.2	Installation procedure.....	25
5.2.1	G-internal-threaded connections.....	25
5.2.2	NPT-internal-threaded connections.....	26
5.2.3	Flange connections.....	27
5.2.4	Connections with external-threaded vacuum fittings.....	27
5.2.5	Connections with external-threaded compression fittings.....	28
5.2.6	Tri-clamp connections.....	28

6	Electrical connection.....	29
6.1	Additional documentation.....	29
6.2	Wire the variant Analogue with D-sub DE-9 male connector	29
6.2.1	Digital input.....	30
6.2.2	Relay output.....	31
6.3	Wire the variant Analogue with a 6-pin terminal strip	32
6.4	Wire the variant Industrial Ethernet.....	33
6.5	Change the network parameters	34
6.5.1	Over the product web-server.....	34
6.5.2	Over the Bürkert Communicator software.....	35
6.6	Wire the variant RS485/Modbus RTU.....	36
6.7	Connect the functional earth.....	37
7	Commissioning.....	38
7.1	Commissioning procedure.....	38
8	Configuration with Bürkert Communicator	39
8.1	Setting tools.....	39
8.2	Connect to the Bürkert Communicator.....	39
8.3	Setting the Industrial Ethernet address.....	40
8.4	Functions	40
8.4.1	Shut-off threshold.....	40
8.4.2	Flush mode	40
8.5	Change of medium.....	41
8.6	User-defined adjustment	41
8.7	Zero point adjustment.....	41
8.8	Set-point sources and operation modes	41
8.9	Operation modes	42
8.10	Normal operation mode	43
8.10.1	Analogue variant.....	44
8.10.2	Industrial Ethernet variant.....	44
8.11	Optimise the closed-loop control parameters	44
8.12	Choose the source that gives the set-point value	45
8.13	Set-point values without communication	46
9	Maintenance.....	47
9.1	Inspect and clean the stainless steel mesh-filter.....	47
9.2	Cleaning and recalibration at the factory	48
9.3	Replace the memory card.....	48
10	Troubleshooting	49
10.1	Status indicator is red	49
10.2	Status indicator is orange	50
10.3	Status indicator is yellow	52
10.4	Status indicator is blue	53

10.5	Status indicator is off	54
10.6	Status indicator goes out periodically.....	54
10.7	Replacement device adopts none of the values from the defective device	54
10.8	Replacement device does not adopt all of the values from the defective device	54
10.9	No mass flow rate	54
10.10	Unstable measured value	55
10.11	Set-point value at 0 %, but medium still flows	56
10.12	Set-point value at 0 %, no mass flow, but a non-zero mass flow rate is measured	57
10.13	Set-point value is not reached	57
10.14	Network status indicator	57
11	Spare parts and accessories	59
11.1	Electrical accessories	59
11.2	Compression fittings for a device with G-internal-threaded connections	59
11.3	Mesh filters.....	60
11.4	Additional software	60
12	Uninstallation.....	61
12.1	Dismantling	61
13	Logistics	62
13.1	Transport and storage	62
13.2	Return	62
13.3	Disposal	62

1 ABOUT THIS DOCUMENT

The document is an important part of the product and guides the user to safe installation and operation. The information and instructions in this document are binding for the use of the product.

- Before using the product for the first time, read and observe the whole safety chapter.
- Before starting any work on the product, read and observe the respective sections of the document.
- Keep the document available for reference and give it to the next user.
- Contact the Bürkert sales office for any questions.



Further information concerning the product at country.burkert.com.

1.1 Manufacturer

Bürkert SAS

20, rue du Giessen

F-67220 TRIEMBACH-AU VAL



The contact addresses are available at country.burkert.com in the menu "Contact".

1.2 Symbols



DANGER!

Warns of a danger that leads to death or serious injuries.



WARNING!

Warns of a danger that can lead to death or serious injuries.



CAUTION!

Warns of a danger that can lead to minor injuries.

NOTICE!

Warns of property damage that can damage the product or the installation.



Indicates important additional information, tips and recommendations.



Refers to information in this document or in other documents.

➔ Indicates a step to be carried out.

✓ Indicates a result.

Menu Indicates a software user-interface text.

1.3 Terms and abbreviations

The terms and abbreviations are used in this document to refer to following definitions.

Device	Type 8745
MFM	Mass flow meter
MFC	Mass flow controller
bar	Unit for relative pressure

2 SAFETY

2.1 Intended use

The device MFM is designed to measure the mass flow rate of clean and dry gases.

The device MFC is designed to measure and regulate the mass flow rate of clean and dry gases.

The permitted media are listed in [Technical data \[▶ 17\]](#).

Prerequisites for safe and trouble-free operation are correct proper transportation, storage, installation, start-up, operation and maintenance.

The instructions are part of the device. The device is intended exclusively for use within the scope of these instructions. Uses of the device that are not described in these instructions, the contractual documents or the type label can lead to severe personal injury or death, damage to the device or property and dangers for the surrounding area or the environment.

- Only trained and qualified personnel may install, operate and maintain the device. See qualification of persons in [Safety instructions \[▶ 8\]](#)
- Use the device only in conjunction with third-party devices and components recommended and authorized by Bürkert.
- Use the device only when it is in perfect condition.
- Only use the device indoors.
- Do not open the device.
- Do not use the device in high-vibration areas.

2.2 Safety instructions

Qualification of personnel working with the device

Improper use of the device can lead to serious personal injury or death. To avoid accidents when working with the device, the following minimum requirements must be met:

- Carry out work on the device within the scope of these instructions in a safety-compliant manner.
- Detect and avoid dangers when working on the device.
- Understand the instructions and implement the information contained therein accordingly.

Responsibility of the operator

The operator is responsible for observing the location-specific safety regulations, also in relation to personnel.

- Observe the general rules of technology.
- Install the device according to the regulations applicable in the respective country.
- The operator must make hazards arising from the location of the device avoidable by providing appropriate operating instructions.

Electrostatically sensitive components and assemblies

The device contains electronic components that are susceptible to the effects of electrostatic discharging (ESD). Components that come into contact with electrostatically charged persons or objects are at risk. In the worst case scenario, these components will be destroyed immediately or fail after start-up.

- Meet the requirements specified by EN 61340-5-1 to minimise or avoid the possibility of damage caused by a sudden electrostatic discharge.
- Do not touch electronic components when the supply voltage is connected.

Electric shock due to electrical components

Touching live parts can result in severe electric shock. This can lead to serious personal injury or death.

- Before working on the device or system, switch off the power supply. Secure it against reactivation.
- Observe any applicable accident prevention and safety regulations for electrical devices.

Changes and other modifications, spare parts and accessories

Changes to the device, incorrect installation or use of non-approved devices or components create hazards that can lead to accidents and injuries.

- Do not make any changes to the device.
- Do not mechanically load the device.
- Observe the operating instructions of the device or component used.
- Only use the devices in conjunction with approved devices or components.

Spare parts and accessories that do not meet Bürkert's requirements may impair the operational safety of the device and cause accidents.

- To ensure operational safety, only use original parts from Bürkert.

Operation only after proper transport, storage, installation, start-up or maintenance.

Improper transport, storage, installation, start-up or maintenance endanger the operational safety of the device and can cause accidents. This can lead to serious personal injury or death.

- Only carry out works which are described in these instructions.
- Only carry out works using suitable tools.
- Have all other works carried out by Bürkert only.

Working on the device

Working on the device that has not been powered down, unauthorised switching on or uncontrolled start-up of the system can cause accidents. This can lead to serious personal injury or death.

- Only work on the device when it is not in use.
- Ensure that the device or system cannot be switched on unintentionally.
- Only start the process in a controlled manner following disruptions. Observe sequence:
 1. Apply supply voltage or pneumatic supply.
 2. Charge the device with medium.

Technical limit values and media

Non-compliance with technical limit values or unsuitable media can damage the device and lead to leaks. This can cause accidents and seriously injure or kill people.

- Comply with limit values. See [Technical data \[▶ 17\]](#) and information on the type label.
- Only feed media into the media ports that are listed in the chapter [Technical data \[▶ 17\]](#).
- Observe the safety data sheet for the media used.

Medium under pressure

Medium under pressure can seriously injure people. In the event of overpressure or pressure surges, the device or lines can burst. Pneumatic lines that are defective or not securely fastened can come loose and swing around.

- Before working on the device or system, switch off the pressure. Vent or empty the lines.
- Adhere to the permitted pressure ranges of the medium.
- Comply with the permitted temperature ranges of the medium.

Hot surfaces and fire hazard

The surface of the device can become hot with fast-switching actuators or with hot media.

- Wear suitable protective gloves.
- Keep highly flammable substances and media away from the device.

3 PRODUCT DESCRIPTION

The device is used for ultimate precision in the feedback control of medium.

This document describes following variant:

- MFM Analogue
- MFM Industrial Ethernet
- MFM RS485/Modbus RTU
- MFC Analogue with proportional valve
- MFC Analogue with motor valve
- MFC Industrial Ethernet with proportional valve
- MFC Industrial Ethernet with motor valve
- MFC RS485/Modbus RTU with proportional valve
- MFC RS485/Modbus RTU with motor valve

3.1 Product overview

MFM

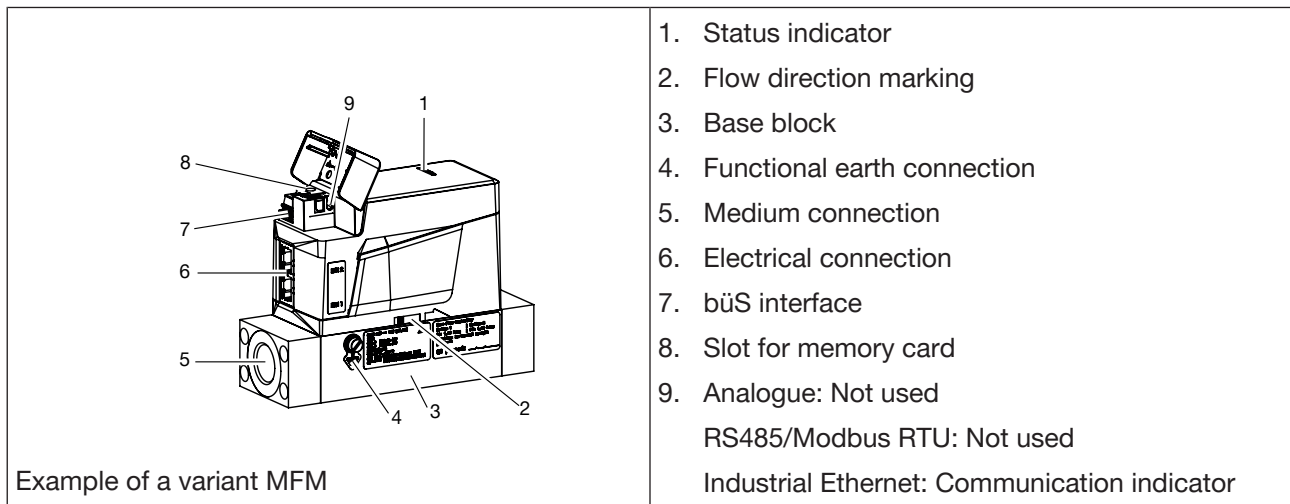

MFC

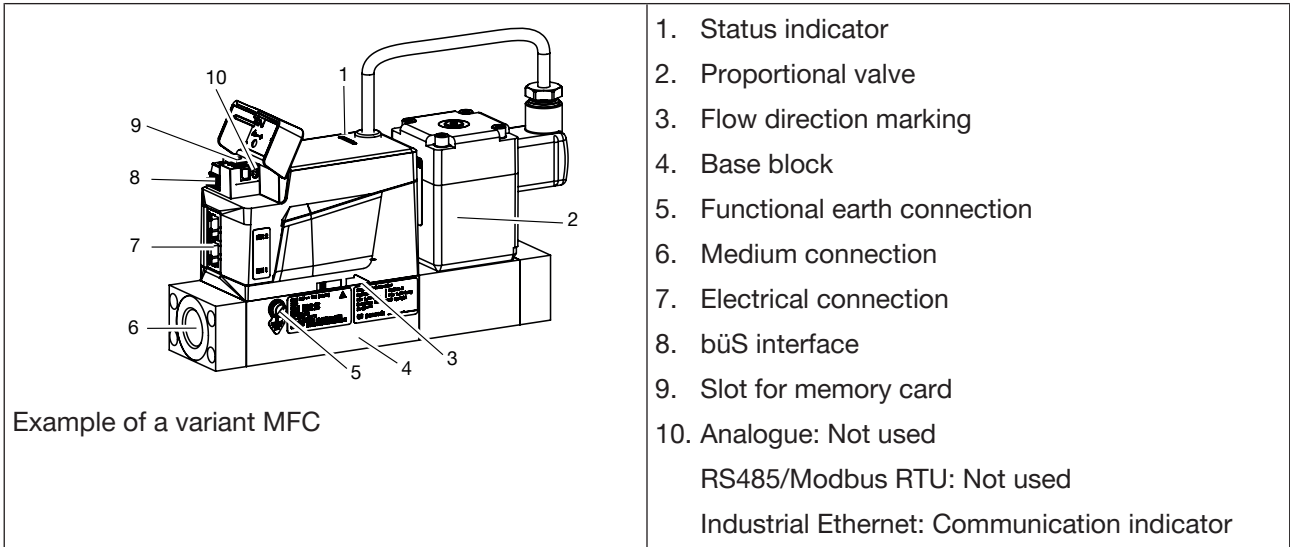

- 1. Status indicator
- 2. Proportional valve
- 3. Flow direction marking
- 4. Base block
- 5. Functional earth connection
- 6. Medium connection
- 7. Electrical connection
- 8. büS interface
- 9. Slot for memory card
- 10. Analogue: Not used
RS485/Modbus RTU: Not used
Industrial Ethernet: Communication indicator

3.2 Product identification

3.2.1 Type label

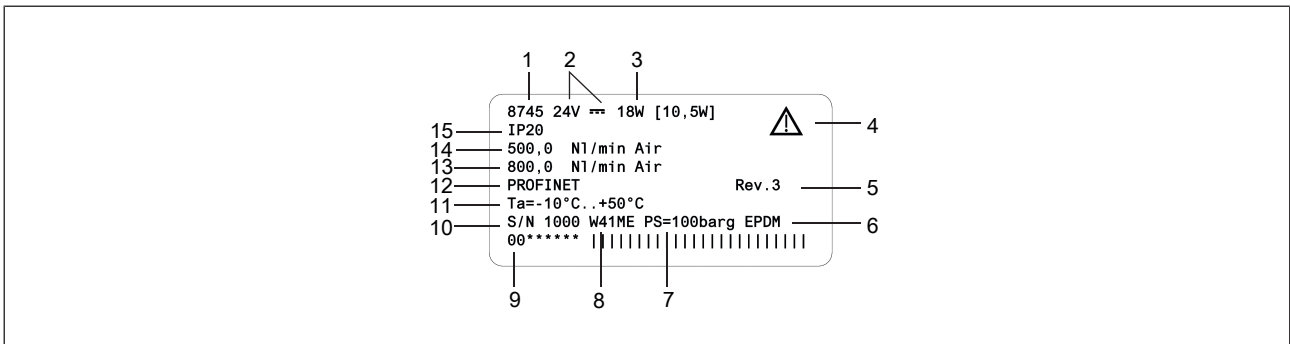

Fig. 1: Example of type label Type 8745

1	Type	2	Operating voltage
3	Power consumption	4	Note: Observe the operating instructions
5	Bürkert internal version	6	Sealing material
7	Maximum operating pressure	8	Manufacture code
9	Article number	10	Serial number
11	Ambient temperature	12	Communication protocol
13	Nominal mass flow rate (Q nominal), unit and operating gas 2	14	Nominal mass flow rate (Q nominal), unit and operating gas 1
15	Degree of protection		

3.2.2 Calibration label

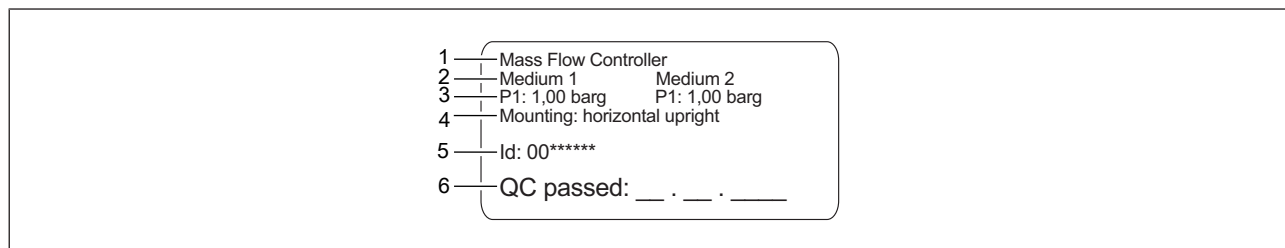

Fig. 2: Example of calibration label

1	Variant	2	Calibration medium
3	Calibration pressure	4	Installation position
5	Article number	6	Calibration date

3.2.3 Conformity marking

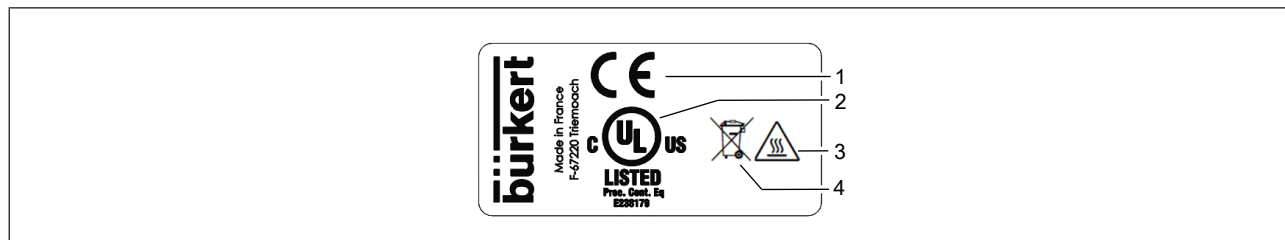

Fig. 3: Conformity label

1	CE marking	2	Certification marking for USA and/or Canada
3	Warning: hot surface	4	Indication for disposal

3.2.4 Symbols and markings on device



Earth terminal



Direct current

Industrial Ethernet variant

DC-B0-58-FF-FF-FF Example of marking of the MAC address

ETH1, ETH2 Ethernet connections

3.3 Display elements

3.3.1 Status indicator

The status indicator changes its colour based on the NAMUR recommendation NE 107. Refer to [NAMUR mode \[▶ 14\]](#).

The colour of the status indicator indicates:

- Whether device diagnostics are active or not. Diagnostics are active on the device and cannot be deactivated.
- If diagnostics are active, then the status indicator shows whether diagnostics events have been generated or not. If several diagnostics events have been generated, then the status indicator shows the diagnostics event with the highest priority.

If the status indicator flashes, then the device is selected in a man-machine interface such as the Bürkert Communicator software.

➔ To solve a problem indicated by the status indicator, refer to [Troubleshooting](#) [▶ 49]

3.3.2 NAMUR mode

The status indicator shows the status of the device and its peripherals, based on NAMUR recommendation 107 (NR 107).

If various alerts are present, the status indicator always shines in the colour of the highest prioritised alert (red = outage = highest priority).

Colour	Colour code	Status	Description
red	5	Failure, error or fault	Due to a malfunction in the device or its periphery, normal operation is not possible.
orange	4	Function check	Work is being carried out on the device, which means that normal operation is temporarily not possible.
yellow	3	Out of specification	The environment conditions or process conditions for the device are not within the specified range. Internal device diagnostics indicate problems within the device or with the process properties.
blue	2	Maintenance required	The device is in normal operation, although a function is briefly restricted. ➔ Service device
green	1	Diagnostics active	Device is running faultlessly, diagnostics are active.
white	0	Diagnostics inactive	Device is switched on, diagnostics are inactive.

Tab. 1: Status indicator according to NE 107

3.3.3 Network status indicator

Industrial Ethernet variant

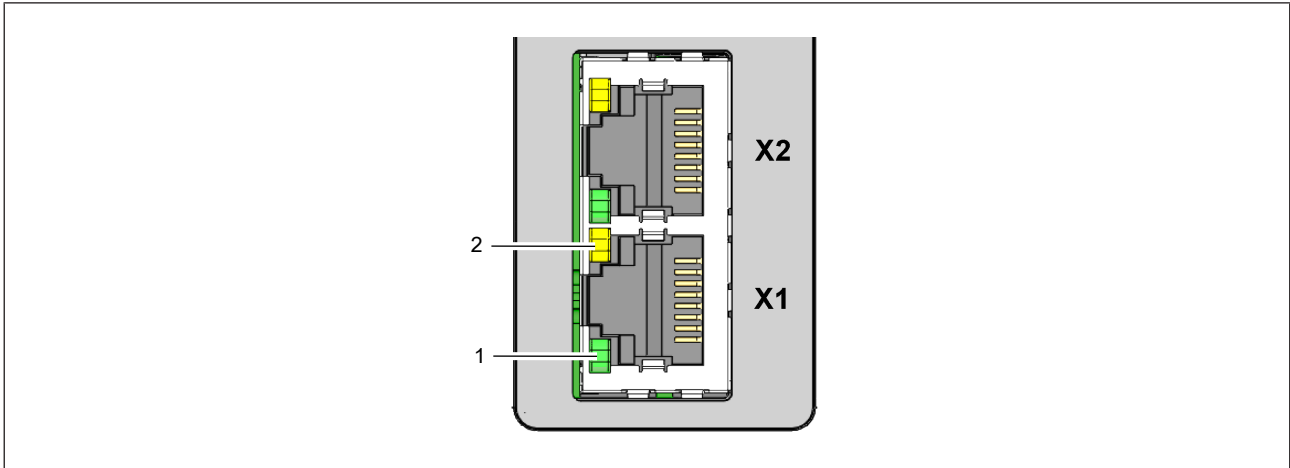

Fig. 4: Location and description of the LED's of an RJ45 socket

1	Link/Act LED (green)	2	Link LED (yellow)
---	----------------------	---	-------------------

3.3.4 Communication indicator

Industrial Ethernet variant

This LED shows the status of the communication between the device and the PLC (Programmable Logical Controller).

LED indicator	Description	Meaning
Green	RUN	Connection to the PLC is active.
Red	ERROR	Connection to the PLC is inactive.

Tab. 2: Description of the communication indicator

3.4 Functionality

3.4.1 Service-büS interface

Analogue variant

Industrial Ethernet variant

RS485/Modbus RTU variant

The Service-büS interface is used for short-term servicing of the device with the Bürkert Communicator.

The Bürkert Communicator runs under Windows. Refer to [Connect to the Bürkert Communicator \[► 39\]](#)

The USB-büS-Interface set, available as an accessory, is necessary. Refer to [Spare parts and accessories \[► 59\]](#)

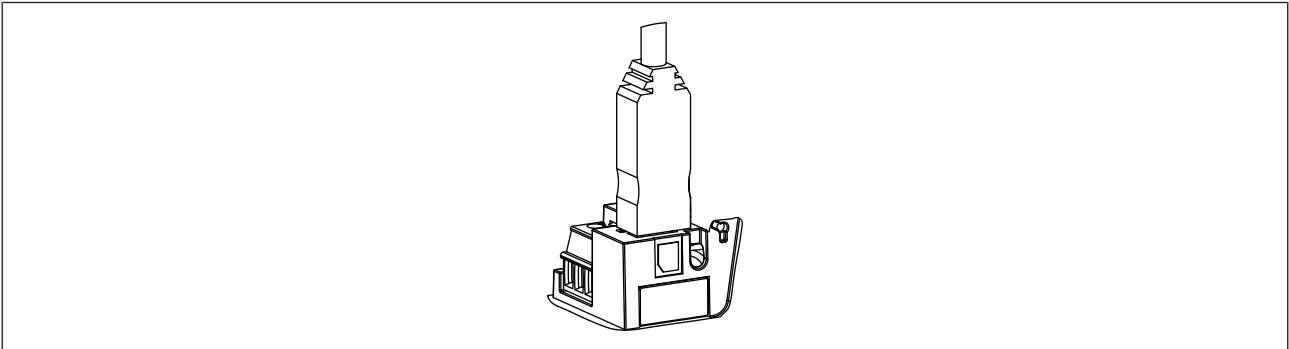

Fig. 5: büS stick, inserted in the related connector of the device

3.4.2 Actuator is a control valve

MFC with proportional valve

The control valve is a direct-acting and normally-closed proportional valve.

The control valve provides the sealing function when the following conditions are met:

- The device is used within the specified pressure range.
- The device is equipped with a valve seat seal that is made of a soft material such as FKM, FFKM or EPDM.



If the valve seat seal is made of a hard material such as PCTFE, then the control valve may not be tight.

Valves with a seat size of 0.05 mm or 0.1 mm have a seat seal made of a hard material.

Unstable measured values may occur. Refer to [Unstable measured value](#) [▶ 55]

3.4.3 Memory card



If the memory card is defective or has been lost, contact your Bürkert sales office to purchase a new one.

The device can be delivered with a memory card that is inserted in the device.

When the device is energised, there are two possibilities:

- If device-specific data is stored on the inserted memory card, then the device adopts the data. At delivery, the memory card contains device-specific data. To get a list of the stored data, refer to the file **Device Description File** that can be downloaded from country.burkert.com.
- If the inserted memory card is empty, then the device loads its own data on the memory card. A new memory card is empty.

The data on the memory card can be transferred to another device with the same article number. For example, the data can be transferred from a defective device to a new device.

4 TECHNICAL DATA

4.1 Standards and directives

The device complies with the valid EU harmonisation legislation. In addition, the device also complies with the requirements of the laws of the United Kingdom.

The harmonised standards that have been applied for the conformity assessment procedure are listed in the current version of the EU Declaration of Conformity/UK Declaration of Conformity.

4.2 Operating conditions

MFM

Ambient temperature	-10...+50 °C
Storage temperature	-10...+70 °C
Degree of protection (EN 60529 / IEC 60529)	IP20*
	<i>*When cables or plugs and sockets are connected correctly, verified by Bürkert, not evaluated by UL.</i>
Medium temperature	<ul style="list-style-type: none"> ■ -10...+70 °C ■ -10...+60 °C for oxygen
Medium	Refer to the type label Clean and dry. Quality classes according to DIN ISO 8573-1.
Operating pressure	Max. 22 bar
Relative air humidity	< 95 %, non-condensing

MFC with proportional valve

Ambient temperature	-10...+50 °C
Storage temperature	-10...+70 °C
Degree of protection (EN 60529 / IEC 60529)	IP20*
	<i>*When cables or plugs and sockets are connected correctly, verified by Bürkert, not evaluated by UL.</i>
Medium temperature	<ul style="list-style-type: none"> ■ -10...+70 °C ■ -10...+60 °C for oxygen
Medium	Refer to the type label Clean and dry. Quality classes according to DIN ISO 8573-1.
Operating pressure	Max. 10 bar (depending on the nominal diameter of the proportional valve)
Relative air humidity	< 95 %, non-condensing

MFC with motor valve

Ambient temperature	-10...+50 °C
Storage temperature	-10...+70 °C
Degree of protection (EN 60529 / IEC 60529)	IP20*
	<i>*When cables or plugs and sockets are connected correctly, verified by Bürkert, not evaluated by UL.</i>
Medium temperature	<ul style="list-style-type: none"> ■ -10...+70 °C ■ -10...+60 °C for oxygen
Medium	Refer to the type label Clean and dry. Quality classes according to DIN ISO 8573-1.
Operating pressure	Max. 22 bar
Relative air humidity	< 95 %, non-condensing

4.3 Medium data

MFM

Calibration medium	Operating fluid or air
Mass flow rate range (reference to N ₂ (I _N /min))	20...2500 I _N /min*
	<i>*Exact range depends on the product base-block size and on the gas used. Refer to the datasheet related to the product type.</i>
Turndown ratio	1:50*
	<i>*Larger measuring range available on request.</i>
Repeatability	±0.1% of the full scale
Measurement accuracy, after 15 minute warm-up time	±1.5%* of the measured value ±0.3%* of the full scale
	<i>* If the operation medium deviates from the calibration medium, the actual measurement accuracy might vary from the value specified in the data sheet. If the medium is natural gas, the measurement accuracy depends on the composition of the natural gas, which can vary depending on the origin and season.</i>
Response time (t95%)	< 500 ms

MFC with proportional valve

Calibration medium	Operating fluid or air
Mass flow rate range (reference to N ₂ (I _N /min))	20...1500 I _N /min*
	<i>*Exact range depends on the product base-block size and on the gas used. Refer to the datasheet related to the product type.</i>

Turndown ratio	1:50*
	*Larger measuring range available on request.
Repeatability	±0.1% of the full scale
Measurement accuracy, after 15 minute warm-up time	±1.5%* of the measured value ±0.3%* of the full scale
	* If the operation medium deviates from the calibration medium, the actual measurement accuracy might vary from the value specified in the data sheet. If the medium is natural gas, the measurement accuracy depends on the composition of the natural gas, which can vary depending on the origin and season.
Settling time (t95%)	< 500 ms

MFC with motor valve

Calibration medium	Operating fluid or air
Mass flow rate range (reference to N ₂ (I _N /min))	20...2500 I _N /min*
	*Exact range depends on the product base-block size and on the gas used. Refer to the datasheet related to the product type.
Turndown ratio	1:50*
	*Larger measuring range available on request.
Repeatability	±0.1% of the full scale
Measurement accuracy, after 15 minute warm-up time	±2%* of the measured value ±0.5%* of the full scale
	* If the operation medium deviates from the calibration medium, the actual measurement accuracy might vary from the value specified in the data sheet. If the medium is natural gas, the measurement accuracy depends on the composition of the natural gas, which can vary depending on the origin and season.
Settling time (t95%)	< 5 s

Quality of the medium

NOTICE!

The medium must obey the quality criteria to obey the following requirements:

- the necessary measurement accuracy of the device
 - to meet the safety requirements
 - to meet the closed-loop control accuracy of an MFC
- ⇒ For further information on the quality criteria, refer to ISO 8573-1.

Criteria	Quality class	Value
Maximum particle size	2	1 µm
Maximum particle density	2	1 mg/m ³

Criteria	Quality class	Value
Maximum dew point under pressure	4	3 °C
Maximum oil concentration	1	0.01 mg/m ³

Tab. 3: Quality criteria of the medium, ISO 8573-1, Compressed Air - Part 1: Contaminants and purity classes

4.4 Electrical data

MFM Analogue

Operating voltage	24 V DC ±10 %
Power consumption	Refer to type label
Analogue input for the measured value 0/4...20 mA	Maximum input impedance: 200 Ω Resolution: 5 µA
Analogue input for the measured value 0...5/10 V	Minimum input impedance: 20 kΩ Resolution: 2,5 mV
Analogue output for the measured value 0/4...20 mA	Maximum loop impedance: 600 Ω at an operating voltage of 24 V DC Resolution: 20 µA
Analogue output for the measured value 0...5/10 V	Maximum current: 20 mA Resolution: 10 mV
Digital input 0...0.2 V	to activate level 1
Digital input 1...4 V or open	to activate level 2
Digital input 5...28 V	to activate level 3
Relay output type	Normally closed contact (break contact), free of potential
Maximum ratings	1 A, 30 V, 30 VA
Electrical connections	<ul style="list-style-type: none"> ■ 6-pin terminal strip, pitch 5.0 mm ■ D-sub DE-9 plug ■ service büS interface
Minimum temperature rating of the cable to be connected to the field wiring terminals:	90 °C

MFM Industrial Ethernet

Operating voltage	24 V DC ±10 %
Power consumption	< 1 W

Communication interface	Industrial Ethernet: PROFINET, EtherNet/IP, EtherCAT, Modbus TCP
Electrical connections	<ul style="list-style-type: none"> ■ 3-pin terminal strip, pitch 3.5 mm ■ 2 RJ45 sockets ■ service bÜS interface
Minimum temperature rating of the cable to be connected to the field wiring terminals:	90 °C

MFM RS485/Modbus RTU

Operating voltage	24 V DC $\pm 10\%$
Power consumption	< 1 W
Communication interface	Modbus RTU (List 0 or 1). The communication parameters can be chosen with the Bürkert communicator software.
Electrical connections	<ul style="list-style-type: none"> ■ D-sub DE-9 plug ■ service bÜS interface
Minimum temperature rating of the cable to be connected to the field wiring terminals:	90 °C

MFC Analogue

Operating voltage	24 V DC $\pm 10\%$ residual ripple < 2 %
Power consumption	Refer to type label
Analogue input for the measured value 0/4...20 mA	Maximum input impedance: 200 Ω Resolution: 5 μ A
Analogue input for the measured value 0...5/10 V	Minimum input impedance: 20 k Ω Resolution: 2,5 mV
Analogue output for the measured value 0/4...20 mA	Maximum loop impedance: 600 Ω at an operating voltage of 24 V DC Resolution: 20 μ A
Analogue output for the measured value 0...5/10 V	Maximum current: 20 mA Resolution: 10 mV
Digital input 0...0.2 V	to activate level 1
Digital input 1...4 V or open	to activate level 2

Digital input 5...28 V	to activate level 3
Relay output type	Normally closed contact (break contact), free of potential
Maximum ratings	1 A, 30 V, 30 VA
Electrical connections	<ul style="list-style-type: none"> ■ 6-pin terminal strip, pitch 5.0 mm ■ D-sub DE-9 plug ■ service bÜS interface
Minimum temperature rating of the cable to be connected to the field wiring terminals:	90 °C

MFC Industrial Ethernet

Operating voltage	24 V DC $\pm 10\%$ residual ripple < 2 %
Power consumption	Refer to type label
Communication interface	Industrial Ethernet: PROFINET, EtherNet/IP, EtherCAT, Modbus TCP
Electrical connections	<ul style="list-style-type: none"> ■ 3-pin terminal strip, pitch 3.5 mm ■ 2 RJ45 sockets ■ service bÜS interface
Minimum temperature rating of the cable to be connected to the field wiring terminals:	90 °C

MFC RS485/Modbus RTU

Operating voltage	24 V DC $\pm 10\%$ residual ripple < 2 %
Power consumption	Refer to type label
Communication interface	Modbus RTU (List 0 or 1). The communication parameters can be chosen with the Bürkert communicator software.
Electrical connections	<ul style="list-style-type: none"> ■ D-sub DE-9 plug ■ service bÜS interface
Minimum temperature rating of the cable to be connected to the field wiring terminals:	90 °C

4.5 Mechanical data

Dimensions	Refer to data sheet
Base block	Aluminium or stainless steel 1.4305
Housing	Polycarbonate (PC)

Seal	Refer to the type label
Status indicator	PMMA
Parts in contact with the medium (sensor)	1.4404, Al ₂ O ₃ , PPS GF40, epoxy resin, silicon, silicon nitride

4.6 Communication

4.6.1 Industrial Ethernet: EtherCAT



Ethernet interface X1, X2	X1: EtherCAT IN X2: EtherCAT OUT
Acyclic communication (CoE)	SDO
Type	Complex Slave
FMMUs	8
Sync Managers	4
Transmission speed	100 Mbit/s
Data transport layer	Ethernet II, IEEE 802.3

EtherCAT® is a registered trademark and patented technology, licensed by Beckhoff Automation GmbH, Germany.

4.6.2 Industrial Ethernet: EtherNet/IP

Pre-defined standard objects	Identity Object (0x01) Message Router Object (0x02) Assembly Object (0x04) Connection Manager (0x06) DLR Object (0x47) QoS Object (0x48) TCP/IP Interface Object (0xF5) Ethernet Link Object (0xF6)
DHCP	supported
BOOTP	supported
Transmission speed	10 and 100 Mbit/s
Duplex modes	Half duplex, full duplex, auto-negotiation
MDI modes	MDI, MDI-X, Auto-MDI-X
Data transport layer	Ethernet II, IEEE 802.3
Address Conflict Detection (ACD)	supported
DLR (ring topology)	supported

CIP reset service	Identity Object Reset Service Type 0 and Type 1
-------------------	---

4.6.3 Industrial Ethernet: Modbus TCP

Modbus function codes	1, 2, 3, 4, 16
Transmission speed	10 and 100 Mbit/s
Data transport layer	Ethernet II, IEEE 802.3

4.6.4 Industrial Ethernet: PROFINET IO

Topology recognition	LLDP, SNMP V1, MIB2, Physical Device
Minimum cycle time	2 ms
IRT	not supported
MRP media redundancy	MRP client is supported
Other supported functions	DCP, VLAN Priority Tagging, Shared Device
Transmission speed	100 Mbit/s
Data transport layer	Ethernet II, IEEE 802.3
PROFINET IO specification	V2.42
Application Relations (AR)	The device can simultaneously process up to 2 IO ARs, 1 Supervisor AR, and 1 Supervisor DA AR.

5 MEDIUM CONNECTION



Risk of injury or material damage when working on the device or system.

→ Read and observe the chapter [Safety \[▶ 8\]](#) before working on the device or system.

5.1 Possible medium connections

- G-internal-threaded connections according to DIN ISO228/1
- NPT-internal-threaded connections according to ASME/ ANSI B 1.20.1
- Flange connection
- Connections with external-threaded vacuum fittings
- Connections with external-threaded compression fittings
- Tri-Clamp

5.2 Installation procedure



WARNING!

Risk of injury that is due to leakage.

At a low mass flow rate and a high pressure, make sure that the installation is tight. The tightness prevents incorrect measurements or leakage of the medium.

To make sure that the installation is tight, observe the following instructions:

- Use compression fittings. Mount the compression fittings in a way that they are not subject to any stresses.
- Use pipes with diameter that is adapted to the medium connection of the device, and a smooth surface.

NOTICE!

Malfunction that is due to contamination.

▶ If a contaminated medium is used, then install a filter upstream of the device. The filter mesh-size must be smaller than 25 µm. The filter ensures problem-free functioning of the device.

5.2.1 G-internal-threaded connections

No inlet section is required.

The connection to the pipe is explained for one side of the device. The same procedure applies on the other side of the device.

- Remove all dirt from the pipes and from the components of the installation that carry the medium.
- Cut the pipe squarely [1] and deburr [2].

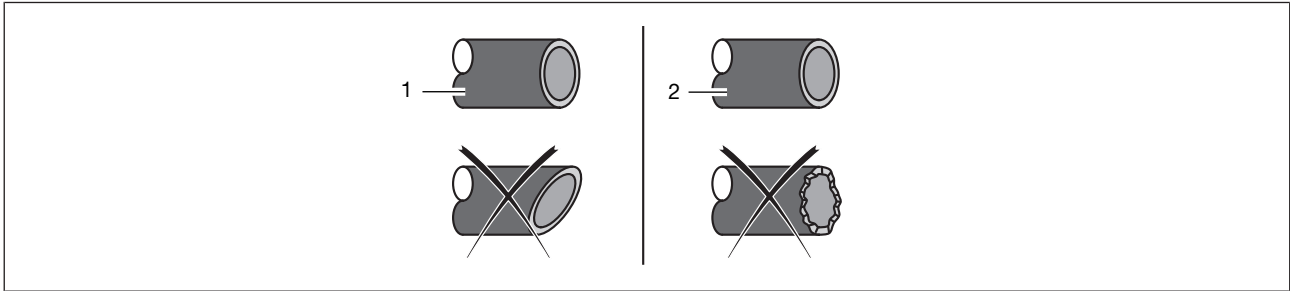

Fig. 6: Pipe cut and deburred

- ➔ Remove the protective cap that closes the threaded connection.

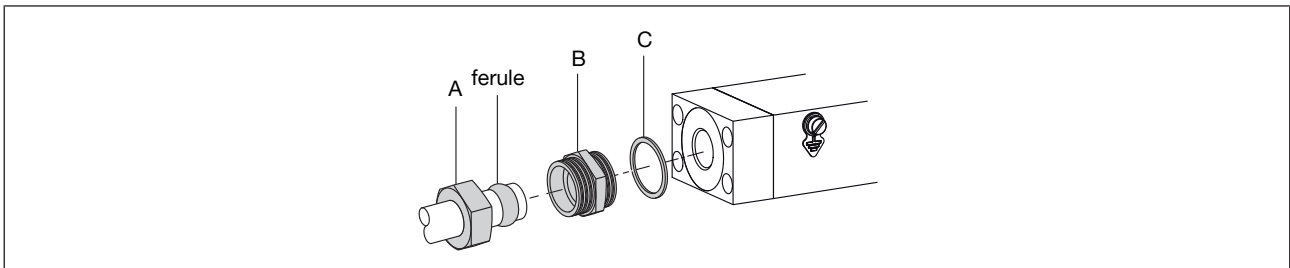

Fig. 7: Nut and ferrule on the pipe

- ➔ Slide the nut [A] and then the ferrule onto the pipe.
- ➔ Place the seal [C] on the medium connection.
- ➔ Screw the compression-fitting body [B] in the medium connection. Tighten to a torque of 25...28 N·m (18.44...20.65 lbf·ft).

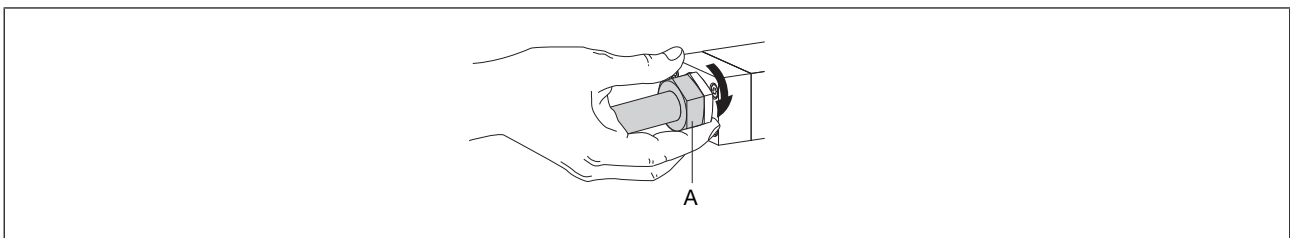

Fig. 8: Nut screwed by hand

- ➔ Insert the pipe in the compression-fitting body. Tighten the nut [A] by hand.

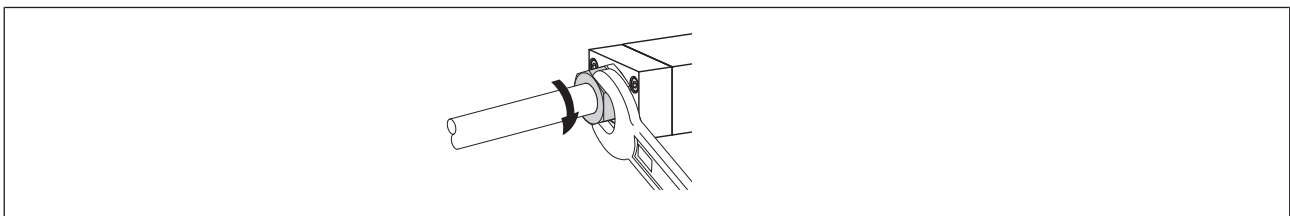

Fig. 9: Nut tightened with an open-end spanner

- ➔ Tighten the nut with an open-end spanner to a torque of 25...28 N·m (18.44...20.65 lbf·ft).
- ➔ Proceed in the same way to connect the medium on the other side.

5.2.2 NPT-internal-threaded connections

No inlet section is required.

The connection to the pipe is explained for one side of the device. The same procedure applies on the other side of the device.

- ➔ Remove all dirt from the pipes and from the components of the installation that carry the medium.

- Cut the pipe squarely [1] and deburr [2].

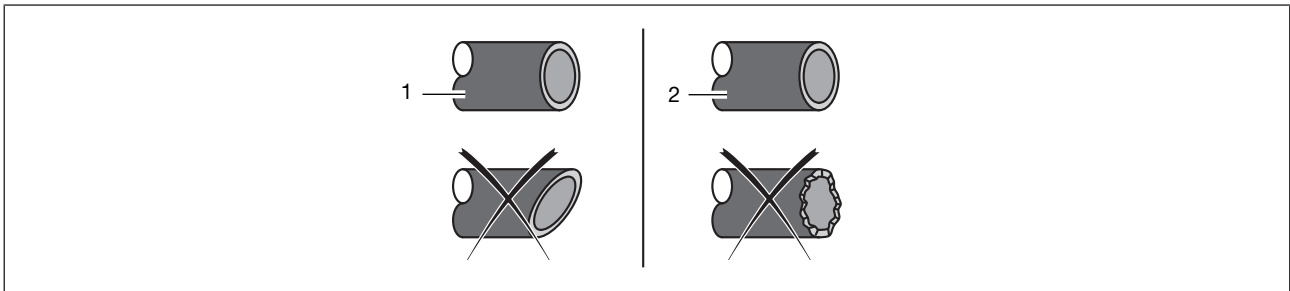

Fig. 10: Pipe cut and deburred

- Remove the protective cap that closes the threaded connection.
- Slide the nut and then the ferrule onto the pipe.
- Connect the medium on one side of the device.
- Obey the instructions that are given by the manufacturer of the fitting used.
- Obey the torques that are given by the manufacturer of the fitting used.
- Proceed in the same way to connect the medium on the other side.

5.2.3 Flange connections

A variant with flange connections is mounted on a process connection plate by the manufacturer.

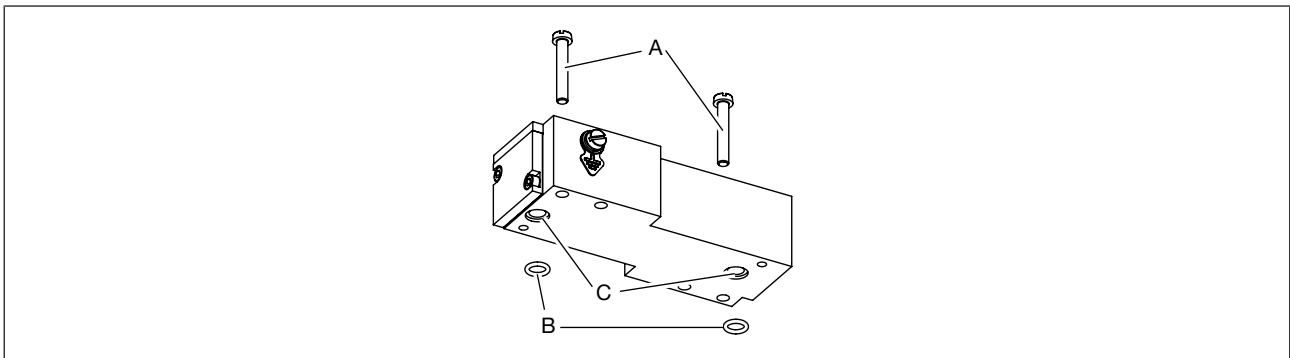

Fig. 11: Flange connection with screws and O-ring sealings

- Use the M4 screws [A] and O-ring sealings [B] delivered with the device.
- Place the O-ring sealings in the cavity [C] of the base block.
- Tighten the screws to a torque of 2,7...2,9 N·m (1,99...2,14 lbf·ft).

5.2.4 Connections with external-threaded vacuum fittings

- Remove the protective cap that closes the connection.
- Do the medium connection on one side of the device.
- Obey the instructions that are given by the manufacturer of the fitting used.
- **CAUTION! To avoid damage on the sealing of the medium connection, please make sure to lock the hexagonal part in place with a second wrench.**
Obey the torques that are given by the manufacturer of the fitting used.
- Do the medium connection on the other side of the device in the same way.

5.2.5 Connections with external-threaded compression fittings

- Do the medium connection on one side of the device.
- Obey the instructions that are given by the manufacturer of the fitting used.
- **CAUTION! To avoid damage on the sealing of the medium connection, please make sure to lock the hexagonal part in place with a second wrench.**
Obey the torques that are given by the manufacturer of the fitting used.
- Do the medium connection on the other side of the device in the same way.

5.2.6 Tri-clamp connections

- Remove the protective cap that closes the threaded connection.
- Do the medium connection on one side of the device.
- Obey the instructions that are given by the manufacturer of the fitting used.
- Do the medium connection on the other side of the device in the same way.

6 ELECTRICAL CONNECTION



Risk of injury or material damage when working on the device or system.

→ Read and observe the chapter [Safety \[▶ 8\]](#) before working on the device or system.

6.1 Additional documentation

- Device description file and object description for the related Type (download from country.burkert.com).
- Device specific help in the Bürkert Communicator software.

6.2 Wire the variant Analogue with D-sub DE-9 male connector

NOTICE!

Requirements for the correct operation of the device.

- Use a power supply unit with sufficient power.
- Use shielded cables only.
- Connect each cable end to the functional earth.
- For an MFC pay attention to the maximum permissible residual ripple on the operating voltage (residual ripple < 2 %).

NOTICE!

UL approved versions must be supplied in one of the following ways:

- "Limited Energy Circuit" (LEC), according to UL / IEC61010-1
- "Limited Power Source" (LPS), according to UL / IEC60950
- SELV / PELV with UL-approved overcurrent protection, designed according to UL / IEC61010-1, Table 18 (e.g. Block PM-0124-020-0)
- NEC Class 2 power supply unit



The cable shield is connected by the housing of the D-sub DE-9 male connector.

MFM

→ Wire a D-sub DE-9 female connector according to the pin assignment.

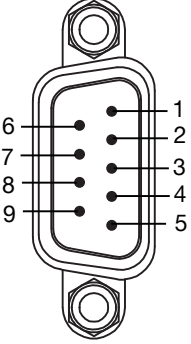
D-sub DE-9 male connector	Pin	Assignment
	1	Digital input
	2	GND for the digital input and the power supply
	3	+24 V DC
	4	Relay: normally closed contact (Break contact)
	5	Relay: reference contact
	6	Not used
	7	Not used
	8	Analogue output for the measured value
	9	GND for the analogue output
Housing		FE

Tab. 4: Pin assignment of the D-sub DE-9 male

- Connect the D-sub DE-9 female connector to the D-sub DE-9 male connector.
- Tighten the screws to a torque of 0,5...0,6 N·m (0,37...0,44 lbf·ft).
- Connect the functional earthing of the device. Refer to [Connect the functional earth \[▶ 37\]](#)

MFC

- Wire a D-sub DE-9 female connector according to the pin assignment.

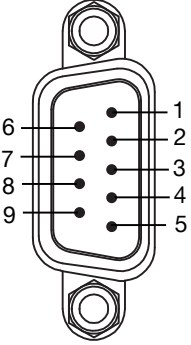
D-sub DE-9 male connector	Pin	Assignment
	1	Digital input
	2	GND for the digital input and the power supply
	3	+24 V DC
	4	Relay: normally closed contact (Break contact)
	5	Relay: reference contact
	6	Set-point input
	7	GND for the set-point input
	8	Analogue output for the measured value
	9	GND for the analogue output
Housing		FE

Tab. 5: Pin assignment of the D-sub DE-9 male

- Connect the D-sub DE-9 female connector to the D-sub DE-9 male connector.
- Tighten the screws to a torque of 0,5...0,6 N·m (0,37...0,44 lbf·ft).
- Connect the functional earthing of the device. Refer to [Connect the functional earth \[▶ 37\]](#)

6.2.1 Digital input

The D-sub DE-9 male connector has a digital input. A digital input is used to remotely trigger a function.

Available functions on MFM

- Reset the totaliser for the active gas.
- Select which gas is active among 3 gases.

Available functions on MFC

- Start the function autotune.
- Trigger the remote control of the actuator or trigger the control of the actuator by the device.
- Reset the totaliser for the active gas.
- Select which gas is active among 3 gases.

Device	Default assignment
MFM	No assignment
MFC	Start autotune

Tab. 6: Default assignment of the digital input

➔ To choose the function to be remotely triggered over the digital input, use the Bürkert Communicator. Only one of the available functions can be associated to the digital input.

A function has 1, 2 or 3 possible switching levels. If a function has several switching levels, then each switching level triggers another action. The following table gives the actions that are associated to the switching levels, and how each level is activated.

Function	Action depending on the activated switching level		
	Level 1	Level 2	Level 3
	Activation: Short circuit the digital input with the digital input ground	Activation: 1...4 V DC (alternatively: not connected)	Activation: 5...28 V DC
MFC: Start autotune	Triggers the function	Not used	Not used
MFC: Actuator control	Triggers the closing of the actuator	Triggers the normal operation mode	Triggers the opening of the actuator
Reset totalizer	Triggers the function	Not used	Not used
Gas selection	Changes to gas number 2	Changes to gas number 1	Changes to gas number 3

Tab. 7: Actions triggered by the switching levels

6.2.2 Relay output

The D-sub DE-9 male connector has a relay output.

MFM

The relay switching can show the following events:

- A warning message has been generated. For example if the supply voltage is too high, then a warning message is generated.
- A failure message has been generated. For example if a sensor failure is detected, then a failure message is generated.

MFC

The relay switching can show the following events:

- A warning message has been generated. For example if the supply voltage is too high, then a warning message is generated.
- A failure message has been generated. For example if a sensor failure is detected, then a failure message is generated.
- The set-point value cannot be reached.
- The device is doing an Autotune.
- The **Set-point value source** has changed.

Device	Default assignment
MFM	No assignment
MFC	The set-point value cannot be reached

Tab. 8: Default assignment of the relay output

→ To choose the events that are assigned to the relay output, use the Bürkert Communicator. Several events can be associated to the relay output.

6.3 Wire the variant Analogue with a 6-pin terminal strip

NOTICE!

Requirements for the correct operation of the device.

- Use a power supply unit with sufficient power.
- Use shielded cables only.
- Connect each cable end to the functional earth.
- For an MFC pay attention to the maximum permissible residual ripple on the operating voltage (residual ripple < 2 %).

NOTICE!

UL approved versions must be supplied in one of the following ways:

- "Limited Energy Circuit" (LEC), according to UL / IEC61010-1
- "Limited Power Source" (LPS), according to UL / IEC60950
- SELV / PELV with UL-approved overcurrent protection, designed according to UL / IEC61010-1, Table 18 (e.g. Block PM-0124-020-0)
- NEC Class 2 power supply unit

6-pin terminal strip	Pin	Assignment
	1	+24 V DC
	2	GND
	3	Set-point analogue input +
	4	Set-point analogue input GND
	5	Actual value analogue output +
	6	Actual value analogue output GND

Tab. 9: Pin assignment of the 6-pin terminal strip

- ➔ Connect the conductors.
- ➔ Tighten the screws at a torque between 0,5...0,6 N·m (0,37...0,44 lbf·ft).
- ➔ Earth the device. Refer to [Connect the functional earth](#) [▶ 37]

6.4 Wire the variant Industrial Ethernet

NOTICE!

Requirements for the correct operation of the device.

- ➔ Use a power supply unit with sufficient power.
- ➔ Use only Industrial Ethernet shielded cables with a category CAT-5e or higher.
- ➔ Connect each cable end to the functional earth.
- ➔ For an MFC pay attention to the maximum permissible residual ripple on the operating voltage (residual ripple < 2 %).

NOTICE!

UL approved versions must be supplied in one of the following ways:

- ➔ "Limited Energy Circuit" (LEC), according to UL / IEC61010-1
- ➔ "Limited Power Source" (LPS), according to UL / IEC60950
- ➔ SELV / PELV with UL-approved overcurrent protection, designed according to UL / IEC61010-1, Table 18 (e.g. Block PM-0124-020-0)
- ➔ NEC Class 2 power supply unit

Connecting the power supply and the functional earth

3-pin terminal strip	Pin	Assignment
	1	FE (functional earth)
	2	DGND
	3	+24 V

Tab. 10: Terminal assignment of the 3-pin terminal strip

- ➔ Open the cover of the device.

- Connect the conductors according to the figure.
- Earth the device. Refer to [Connect the functional earth](#) [▶ 37]
- Tighten the conductors at a torque between 0.22...0.25 N (0.16...0.18 lbf·ft.)

Connecting the Industrial Ethernet

The cable shield is connected by the housing of the cable plug.

Both RJ45 sockets have the same pin assignment.

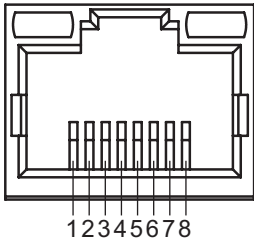
RJ45	Pin	Assignment
	1	TX+
	2	TX-
	3	RX+
	4	N. C.
	5	N. C.
	6	RX-
	7	N. C.
	8	N. C.
Housing		FE

Tab. 11: Pin assignment of an RJ45 socket

- If a protocol other than EtherCAT is used, plug an Ethernet cable in one or both sockets.
- If the EtherCAT protocol is used, plug the incoming Ethernet cable (coming from the PLC) into the socket marked ETH1 and plug the outgoing Ethernet cable into the socket marked ETH2.

6.5 Change the network parameters

Industrial Ethernet variant



The Industrial Ethernet variants Ethernet/IP and ModbusTCP have the same default IP address 192.168.1.100, Profinet devices have 0.0.0.0 by default.

- Before commissioning the device, change its network parameters.
- If several devices must be connected to the same Industrial Ethernet network, then connect one device at a time and change its network parameters.

6.5.1 Over the product web-server

NOTICE!

Security risk due to default passwords.

Unauthorised persons can log in to the web server and change the parameters.

- Change the default passwords.
- If the web server is not needed, then disable access with the Bürkert Communicator software, refer to [Configuration with Bürkert Communicator](#) [▶ 39]

Prerequisites:

- The industrial Ethernet variant is not EtherCAT
 - Digital device (PC, tablet,...) with a web browser.
 - Possibly, a USB-Ethernet adapter.
- Connect the device to the digital device with an Ethernet cable. Alternatively, it's possible to connect the device to the PC over a USB-Ethernet adapter.
- Energise the digital device and the device.
- If the device is connected to the digital device over a USB-Ethernet adapter, then configure the IP address of the USB-Ethernet adapter. Else, configure the IP address of the network card of the digital device.
- Change the IP address to 192.168.1.xxx, where xxx is different from 100.
- Open the web browser. In the address bar of the web browser, enter 192.168.1.100.
- ✓ The home page of the web server opens. Some device data are shown.
- Open a web server session, to configure the network parameters of the device.
- If you are not automatically invited to log in, choose **Login**.
- **User name**: enter admin
- **User password**: enter admin
- Click **Login**.
- Change the default passwords with customized passwords.
- Change the network parameters of the device.
- Go to **Industrial communication** > **Configuration**.
- Change the parameters.
- To save the changes, choose **Apply**.
- To update the parameters, choose **Restart**.
- ✓ The device restarts.
 - ✓ The network parameters of the device are changed.

6.5.2 Over the Bürkert Communicator software

- Connect the device to the Bürkert Communicator software. Refer to [Configuration with Bürkert Communicator \[▶ 39\]](#).
- Change the network parameters of the device.
- Go to **Industrial communication** > **Parameter**.
- Change the parameters.
- To update the parameters, restart the device.
- ✓ The device restarts.
 - ✓ The network parameters of the device are changed.

6.6 Wire the variant RS485/Modbus RTU

NOTICE!

Requirements for the correct operation of the device.

- Use a power supply unit with sufficient power.
- Use shielded cables only.
- Connect each cable end to the functional earth.
- For an MFC pay attention to the maximum permissible residual ripple on the operating voltage (residual ripple < 2 %).

NOTICE!

UL approved versions must be supplied in one of the following ways:

- "Limited Energy Circuit" (LEC), according to UL / IEC61010-1
- "Limited Power Source" (LPS), according to UL / IEC60950
- SELV / PELV with UL-approved overcurrent protection, designed according to UL / IEC61010-1, Table 18 (e.g. Block PM-0124-020-0)
- NEC Class 2 power supply unit



The cable shield is connected by the housing of the D-sub DE-9 male connector.

- Wire a D-sub DE-9 female connector according to the pin assignment.

D-sub DE-9 male connector	Pin	Assignment
	1	Not used
	2	GND
	3	+24 V DC
	4	Not used
	5	Not used
	6	TX+ (RS485-Y) * bridge with Pin 9 for Half-Duplex
	7	TX- (RS485-Z) *bridge with Pin 8 for Half-Duplex
	8	RX- (RS485-B)
	9	RX+ (RS485-A)
Housing		FE

Tab. 12: Pin assignment of the D-sub DE-9 male

- Connect the D-sub DE-9 female connector to the D-sub DE-9 male connector.
- Tighten the screws to a torque of 0,5...0,6 N·m (0,37...0,44 lbf·ft).
- Connect the functional earthing of the device. Refer to [Connect the functional earth \[▶ 37\]](#)

6.7 Connect the functional earth

WARNING!

Risk of ignition and risk of fire that are due to electrostatic discharge.

An electrostatic discharge of the device can ignite combustible gas vapours.

- To avoid a build up of electrostatic charge, connect the housing to the functional earth.
 - If the functional earth is not attached, then the requirements of the EMC directive are not met.
-
- Use a green-and-yellow cable that is as short as possible. And the cable cross-section must be at least equal to the cross section of the power-supply cable.
 - With a flat screwdriver of size 6.5 mm, loosen the M4 screw.

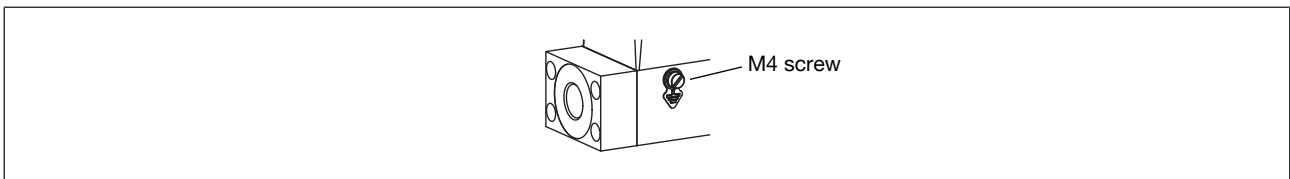

Fig. 12: Location of the M4 screw for the connection of the functional earth

- Attach the green-and-yellow cable to the M4 screw with a cable lug.
- Tighten the M4 screw to a torque of 1,8 N·m...2 N·m (1,33 lbf·ft...1,47 lbf·ft).

7 COMMISSIONING



Risk of injury or material damage when working on the device or system.

→ Read and observe the chapter [Safety \[▶ 8\]](#) before working on the device or system.

7.1 Commissioning procedure

- Pressurise the pipes with medium.
- Flush the pipes with medium at the calibration pressure.
- Vent the pipes completely.
- Check if the memory card is inserted.
- Energise the device.
- If the device is an MFC, and the medium is not the calibration medium or the pressure conditions have changed, then run the Autotune function. Refer to [Optimise the closed-loop control parameters \[▶ 44\]](#)

The device operates normally.

8 CONFIGURATION WITH BÜRKERT COMMUNICATOR

8.1 Setting tools



The MassFlowCommunicator is another PC software that is not compatible with the device. The MassFlowCommunicator software cannot be used to configure or operate the device.

Settings can be made with the Type 8920 Bürkert Communicator.

- Connect the device to the Bürkert Communicator. Refer to [Connect to the Bürkert Communicator](#) [▶ 39]
- For general information about the Bürkert Communicator, refer to the Type 8920 operating instructions.

8.2 Connect to the Bürkert Communicator

Applicable for:

- Analogue variant
- Industrial Ethernet variant
- RS485/Modbus RTU variant
- Use the USB-büS-Interface set with article number 00772551.
- Download the latest version of the Type 8920 Bürkert Communicator from country.burkert.com.
- Install the Bürkert Communicator on a PC. During installation, the büS stick must not be inserted at the PC.
- Assemble the parts of the USB-büS-Interface set.



Fig. 13: Assembled parts of the USB-büS-Interface set

- Set the termination-resistance switch of the büS stick to ON.
- Insert the büS stick into a USB port of the PC.
- Energise the device. Refer to [Electrical connection](#) [▶ 29]
- Insert the micro-USB connector into the büS interface for the Bürkert Communicator.
- Wait until the driver of the büS stick has been completely installed on the PC.
- Start the Bürkert Communicator.

- Click on  in the Bürkert Communicator to establish the communication with the device.

✓ A window opens.

→ Select **Connect via USB (büs Stick)**.

→ Choose the port **Bürkert USB büS stick**, click on **Finish** and wait until the device symbol appears in the list of devices.

→ In the navigation area, click on the symbol related to the device: The device menu appears.

8.3 Setting the Industrial Ethernet address

→ To set the fieldbus address, use the Bürkert Communicator.

→ Or use the man-machine interface of the PLC the device is connected to.

→ If the address is changed and to avoid malfunction of the device, restart the device by turning off and on the power supply.

8.4 Functions

8.4.1 Shut-off threshold

Only MFC variant

A shut-off threshold ensures the sealing function of the control valve (except valve with PCTFE seat sealing). If the Used set-point value is below the shut-off threshold (**Controller** > **Parameter** > **Set-point value**), the control signal for the valve is set to 0%.

The Used set-point value depends on the setpoint source (**Controller** > **Parameter** > **Set-point value**).

Depending on the measuring span (**Sensor** > **Parameter**), the Used set-point value is set to zero:

Measuring span > 2%	limit=Measuring span - 1%
Measuring span <= 2%	limit=Measuring span * 0,5

Tab. 13: Decreasing setpoint

Measuring span > 2%	limit=Measuring span -0,5%
Measuring span <= 2%	limit=Measuring span * 0,75

Tab. 14: Increasing setpoint

When the shut-off threshold is deactivated (zero) and Used set-point value = 0, the controller stays in closed loop control until Actual value flow (filtered only by x-filter control input) < Measuring span * 0,25

8.4.2 Flush mode

Industrial Ethernet variant

RS485/Modbus RTU variant



MFC: If the integrated valve is fully open, the internal device temperature increases. If the internal device temperature increases, the device can be damaged.

→ Do not let the valve fully open for more than 10 minutes.

To open the valve completely:

→ Send an acyclic command to the device.

→ Or send a cyclic command with the double nominal flow rate.

8.5 Change of medium

At delivery the device is calibrated by the manufacturer with Nitrogen and a conversion factor to the medium.

With the Bürkert Communicator, it is possible to change the medium by using a LUA-Script which can be downloaded at country.burkert.com.

To perform the LUA-Script:

- Start communication with Bürkert Communicator. Refer to [Connect to the Bürkert Communicator \[▶ 39\]](#)
- Choose the device.
- Select **File** > **Scripts**.
- Browse the downloaded zip-File.
- ✓ The procedure of changing medium starts.

8.6 User-defined adjustment

At delivery the device is calibrated by the manufacturer.

With the Bürkert Communicator, it is possible to define an adjustment procedure with up to 32 calibration points.

This procedure is described in device specific **Documents and tools** in the Bürkert Communicator.

- Connect the device to the Bürkert Communicator. Refer to [Connect to the Bürkert Communicator \[▶ 39\]](#)

8.7 Zero point adjustment

The zero point adjustment is done by the manufacturer. It is possible to perform a zero point adjustment procedure to adapt the sensor characteristic curve to the current conditions (mounting/installation position, medium, operating pressure). The device will be calibrated in horizontal installation position in any case. It is possible to use another installation position. Afterwards a zero point adjustment procedure might be useful.

- Start the communication with the Bürkert Communicator. Refer to [Connect to the Bürkert Communicator \[▶ 39\]](#)
- Choose the device.
- Select **Sensor** > **Diagnostics** > **Zero point adjustment**
- ✓ The procedure starts.

8.8 Set-point sources and operation modes

Only MFC variant

The process set-point value can be set by different sources. It is possible to choose which source is active at a time. The source for the set-point value can be changed during operation. If the source for the set-point value is changed, then the operation mode of the device is changed.

When energising the device for the first time, the device enters a short initialisation phase and then switches to the normal operation mode.

- Connect the device to the Bürkert Communicator. Refer to [Connect to the Bürkert Communicator \[▶ 39\]](#).
- Choose the device.

→ Select **Controller** > **Parameter** > **Set-point value** > **Set-point value source**



The **Set-point value source** is kept after a restart, except when the chosen set-point source is **Manual set-point value** or **Analyze system**.

Set-point value source	Description	Operation mode
Analog set-point value source Only variant Analogue	The set-point value is set through the analogue input.	Normal operation mode (Closed-loop)
Automatic Only variant Industrial Ethernet	The set-point value is set via the fieldbus. If different fieldbus participants simultaneously specify a set-point value for the device, it is always the last set value that is used.	Normal operation mode (Closed-loop)
Manual set-point value	To manually give in a set-point value for testing purposes or to make sure that the set-point value is not overwritten by other fieldbus participants	Normal operation mode (Closed-loop)
Stored set-point value	To use a fixed set-point value (w). If the device is restarted, then the fixed set-point value remains active.	Normal operation mode (Closed-loop)
Open-loop control mode	To directly set the set-point position (y) to the actuator. The value that is given in the menu Actuator > Parameter > Actuating variable is the setpoint position (y) that is used. A restart of the device sets the setpoint position (y) to zero.	Open-loop control mode
Analyze system	The device operates in the normal operation mode, but according to a predefined chronological sequence with set-point values. Use the resulting diagram in combination with the graphical representation of process values to analyse the system with the Bürkert Communicator.	Analyse the system

Tab. 15: Set-point sources and operation modes

8.9 Operation modes

Only MFC variant

When energising the device for the first time, the device enters a short initialisation phase and then switches to the normal operation mode.

Operating mode	Refer to
Variant Industrial Ethernet: Automatic	Normal operation mode [▶ 43]
Variant Analogue: Analog set-point value	Normal operation mode [▶ 43]
Manual set-point value	Choose the source that gives the set-point value [▶ 45]
Stored set-point value	Choose the source that gives the set-point value [▶ 45]
Open-loop control mode	Choose the source that gives the set-point value [▶ 45]
Analyze system	Choose the source that gives the set-point value [▶ 45]

Tab. 16: Possible operating modes in the Bürkert Communicator software

➔ To change the operation mode, change the source for the set-point values. Refer to [Choose the source that gives the set-point value \[▶ 45\]](#)

The operation mode is kept after a device restart, except when the device performs the function **Analyze system**.

8.10 Normal operation mode

Only MFC variant

The normal operation mode is active when energising the device for the first time.



If the valve seat seal is made of a hard material such as PCTFE, then the control valve may not be tight.

Valves with a seat size of 0.05 mm or 0.1 mm have a seat seal made of a hard material.

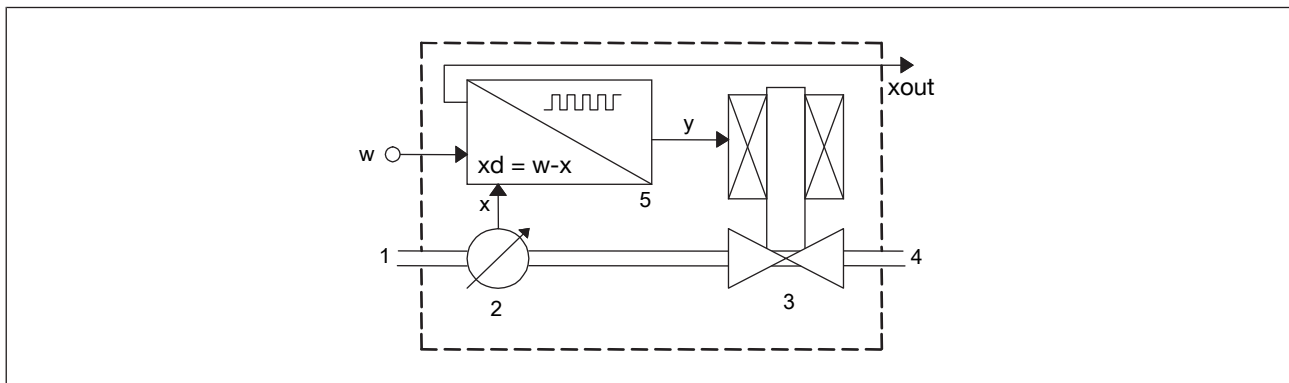

Fig. 14: Function diagram of the MFC with control valve

1	Medium inlet	2	Sensor
3	Control valve	4	Medium outlet
5	Electronics	x	measured value of the mass flow rate
y	set-point position of the pump	w	set-point value of the mass flow rate

The sensor measures the mass flow rate and compares the measured value x with the set-point value w . The device calculates the set-point position value y of the actuator.

- If the actuator is a control valve, then the set-point position value y determines the opening of the control valve. For example, if the set-point position value y is equal to 10%, then the opening of the control valve is 10%.

The transmission means of the set-point value w and the measured value of the flow rate depends on the device.

- ➔ If the operating conditions have changed, then optimise the closed-loop control parameters. Refer to [Optimise the closed-loop control parameters](#) [▶ 44]
- ➔ To change the operation mode, change the source for the set-point value. Refer to [Choose the source that gives the set-point value](#) [▶ 45]

8.10.1 Analogue variant

After applying the operating voltage, the device enters a short initialisation phase and then switches to the normal operation mode. The normal operation mode of a variant Analogue is the **Analog set-point value** operation mode.

- The set-point value w is transmitted over the set-point analogue input according to the ranges in the following table.
- The measured value of the flow rate is transmitted over the analogue output according to the ranges in the following table.

Analogue output range	Minimum value of the input ranges and output ranges	Maximum value of the input ranges and output ranges
4...20 mA	4 mA, $w = 0\%$	20 mA, $w = 100\%$
0...20 mA	0 mA, $w = 0\%$	20 mA, $w = 100\%$
0...5 V	0 V, $w = 0\%$	5 V, $w = 100\%$
0...10 V	0 V, $w = 0\%$	10 V, $w = 100\%$

Tab. 17: Analogue-input ranges and analogue-output ranges

8.10.2 Industrial Ethernet variant

After applying the operating voltage, the device enters a short initialisation phase and then switches to the **Automatic** operation mode.

- ➔ To change the control mode, i. e. to change the source for the set-point values. Refer to [Choose the source that gives the set-point value](#) [▶ 45]
- ➔ To change the control parameters, use the Bürkert Communicator.

8.11 Optimise the closed-loop control parameters

Only MFC variant

The closed-loop control parameters of the device can be optimised for the current operating conditions with a function that is called Autotune.

- Run the Autotune function when the device is started for the first time.
- If the operating conditions have changed, then run the Autotune function.

If the device detects that the pipe is empty, then the Autotune function cannot be started.

When the Autotune is running:

- Do not interrupt the power supply to the MFC.
- Keep the supply pressure constant.



WARNING!

Risk of injury from flowing medium.

While the Autotune function is running, the mass flow rate value can be higher than the nominal flow rate value.

- Before running the Autotune function, make sure that no danger can occur if the mass flow rate value increases.
- Trigger the Autotune function with one of the following means:
 - over the fieldbus (variant Industrial Ethernet)
 - over the fieldbus (variant RS485 / Modbus RTU)
 - over the digital input (variant Analogue),
 - with the Bürkert Communicator. Refer to [Connect to the Bürkert Communicator](#) [▶ 39]
- ✓ The Autotune runs and the status indicator is orange.
- ✓ The MFC temporarily stops regulating the flow rate in the pipe.
- ✓ When the function is completed, the device returns to its previous operating mode.
- ✓ If the function is completed successfully, then the optimised closed-loop control parameters are transferred to the hard memory of the device.

8.12 Choose the source that gives the set-point value

Only MFC variant

The process set-point value can be set by different sources. It is possible to choose which source is active at a time. The source for the set-point value can be changed during operation.

If the source for the set-point value is changed, then the operation mode of the device is changed.

To change the source for the set-point value, change the setting of the parameter **Set-point value source** with the Bürkert Communicator. Refer to [Connect to the Bürkert Communicator](#) [▶ 39]

On a Industrial Ethernet variant it is possible to alternatively change the related object. Refer to the related procedure in the device-specific help in the documentation of the initiation files. Download the initiation files and the related documentation at country.burkert.com.



The setting of the parameter **Set-point value source** is kept after a restart, except when the device performs the function **Analyze system** or the set-point value source was set to manual set-point.

The possible choices for the parameter **Set-point value source** are:

- Variant Analogue: **Analog set-point value**: the setpoint value is set via the analogue input.
- Variant Industrial Ethernet: **Automatic**: the set-point value is set via the fieldbus. If different fieldbus participants simultaneously specify a set-point value for the device, it is always the last set value that is used.
- **Manual set-point value**: to manually give in a set-point value for testing purposes or to make sure that the set-point value is not overwritten by other fieldbus participants.
- **Stored set-point value**: to use a fixed set-point value (w). If the device is restarted, then the fixed set-point value remains active.
- **Open-loop control mode**: to directly set the set-point position (y) to the actuator. The value that is given in the menu **Actuator** > **Parameter** > **Actuating variable** is the setpoint position (y) that is used. A restart of the device sets the set-point position (y) to zero.
- **Analyze system**: the device operates in the normal operation mode, but according to a predefined chronological sequence with set-point values. Use the resulting diagram in combination with the graphical representation of process values to analyse the system with the Bürkert Communicator.

8.13 Set-point values without communication

Applicable for:

- Industrial Ethernet variant
- RS485/Modbus RTU variant

The function makes it possible to specify the set-point values of the device even if the communication with the external set-point value provider (for example a PLC) is broken. If the function is used, then the set-point is kept constant.



By using the function, the medium can continue to flow even if the communication is broken.

→ Make sure the process is safe when the function is used.

→ To use the function, refer to the related procedure in the specific help in the documentation of the initiation files. Download the initiation files and the related documentation at country.burkert.com

9 MAINTENANCE

If the device is operated according to the Operating instructions, then the device is maintenance-free.



Risk of injury or material damage when working on the device or system.

→ Read and observe the chapter [Safety](#) [▶ 8] before working on the device or system.

9.1 Inspect and clean the stainless steel mesh-filter

The inspection and possibly cleaning of the stainless steel meshfilter must be done at regular intervals. The inspection frequency and cleaning frequency depend on the measured medium.

If a contaminated medium is used, then clean the stainless steel mesh-filter immediately. If the stainless steel mesh-filter is contaminated, then replace it with a new one.

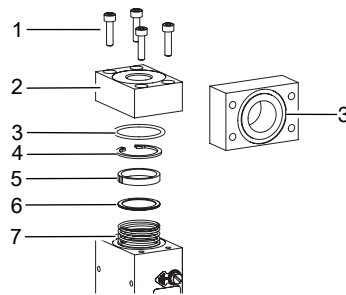

Fig. 15: Parts in contact with the medium

1	Screws	2	Flange plate
3	O-ring	4	Circlip
5	Ring	6	Stainless steel mesh-filter
7	Compression spring		

- Position the device upright with the medium inlet at the top.
- With an hexagon key of size 3 mm, loosen the screws [1] and remove the flange plate [2]. The O-ring [3] remains in the groove on the rear side of the flange plate.
- With a pair of tweezers, carefully remove the circlip [4] because the mesh filter [6] and the ring [5] will be pushed out by the compression spring [7].
- **CAUTION! Do not clean the mesh filter with tap water.** Clean the stainless steel mesh-filter [6] with acetone, isopropanol or compressed air.
- Dry the mesh filter.
- **CAUTION! Before mounting the parts back, make sure that the fine side of the mesh filter [6] faces the flange plate [2]**
- Push back the compression spring [7] together with the mesh filter [6] into the base block and secure them with the circlip [4].
- Make sure that the mesh filter and the O-ring are seated flat and not tilted.
- Insert the flange plate [2] and the screws [1].
- Tighten the screws to a torque of 2.8 N·m (2.06 lbf·ft).

9.2 Cleaning and recalibration at the factory

If the device is contaminated or damaged by operation, then the measured mass flow rate could no longer correspond to the actual mass flow rate.

- Send the device back to the manufacturer because it must be replaced and recalibrated. Observe the return procedure given in [Return \[▶ 62\]](#)

9.3 Replace the memory card

Analogue variant

Industrial Ethernet variant

RS485/Modbus RTU variant

- De-energise the device.
- With tweezers slightly push the memory card to the stop in the device and release. The old memory card comes out.
- Pay attention to the insertion direction of the memory card.

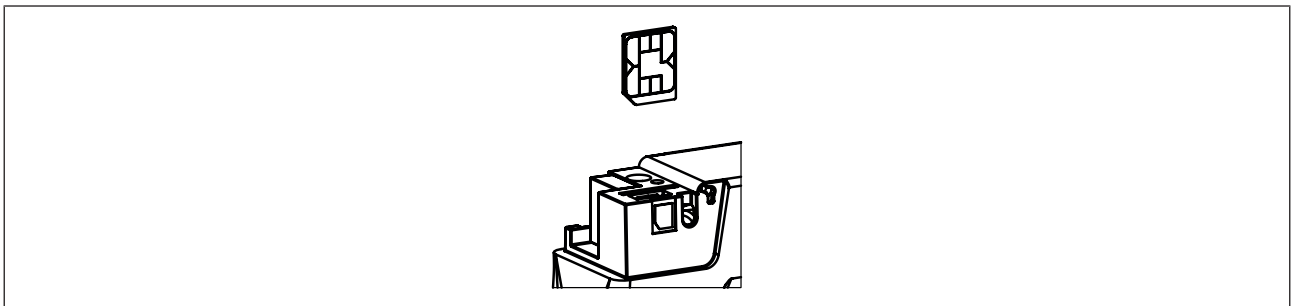

Fig. 16: Insertion direction of the memory card

- Push the new memory card in the slot until you hear a locking noise. If the memory card comes out, the locking failed.

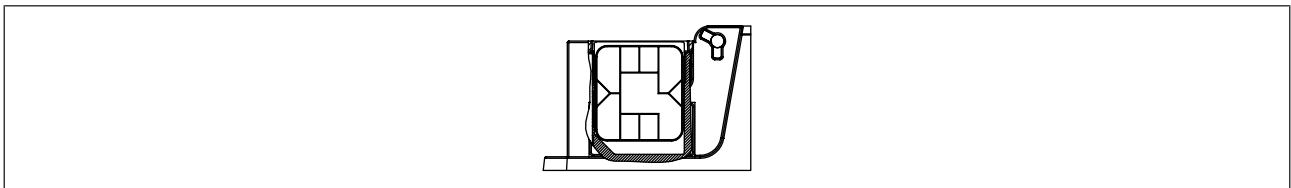

Fig. 17: Inserted memory card

- Restart the device to write the data on the new memory card. Possible problems related to the memory card are given in [Troubleshooting \[▶ 49\]](#)

10 TROUBLESHOOTING

10.1 Status indicator is red

MFM Analogue

Cause	Solution
The supply voltage is out of the error range. The device can be damaged.	→ Operate the device within the specifications. If the status indicator is still red, then send the device back to Bürkert.
The sensor, the internal memory or the device is defective.	→ Contact the manufacturer, because maintenance is needed.

MFM Industrial Ethernet

Cause	Solution
The supply voltage is out of the error range. The device can be damaged.	→ Operate the device within the specifications. If the status indicator is still red, then send the device back to Bürkert.
The sensor, the internal memory or the device is defective.	→ Contact the manufacturer, because maintenance is needed.
No proper connection to the PLC.	<ul style="list-style-type: none"> → Check the wiring. → Check the status of the PLC. → If the EtherCAT protocol is used, make sure the incoming cable (reception from the PLC) is inserted in the ETH1 port and the outgoing cable is inserted in the ETH2 port.

MFM RS485/Modbus RTU

Cause	Solution
The supply voltage is out of the error range. The device can be damaged.	→ Operate the device within the specifications. If the status indicator is still red, then send the device back to Bürkert.
The sensor, the internal memory or the device is defective.	→ Contact the manufacturer, because maintenance is needed.
No proper connection to the PLC.	<ul style="list-style-type: none"> → Check the wiring. → Check the status of the PLC.

MFC Analogue

Cause	Solution
The supply voltage is out of the error range. The device can be damaged.	→ Operate the device within the specifications. If the status indicator is still red, then send the device back to Bürkert.
Incorrect Autotune or Autotune aborted.	<ul style="list-style-type: none"> → Make sure that the medium flows through the device. → Check the Q_{nom} of the device. → Start the Autotune again. <p>After a restart of the device, the error will be reset.</p>

Cause	Solution
The sensor, the internal memory or the device is defective.	→ Contact the manufacturer, because maintenance is needed.

MFC Industrial Ethernet

Cause	Solution
The supply voltage is out of the error range. The device can be damaged.	→ Operate the device within the specifications. If the status indicator is still red, then send the device back to Bürkert.
Incorrect Autotune or Autotune aborted.	<ul style="list-style-type: none"> → Make sure that the medium flows through the device. → Check the Q_{nom} of the device. → Start the Autotune again. After a restart of the device, the error will be reset.
The sensor, the internal memory or the device is defective.	→ Contact the manufacturer, because maintenance is needed.
No proper connection to the PLC.	<ul style="list-style-type: none"> → Check the wiring. → Check the status of the PLC. → If the EtherCAT protocol is used, make sure the incoming cable (reception from the PLC) is inserted in the ETH1 port and the outgoing cable is inserted in the ETH2 port.

MFC RS485/Modbus RTU

Cause	Solution
The supply voltage is out of the error range. The device can be damaged.	→ Operate the device within the specifications. If the status indicator is still red, then send the device back to Bürkert.
Incorrect Autotune or Autotune aborted.	<ul style="list-style-type: none"> → Make sure that the medium flows through the device. → Check the Q_{nom} of the device. → Start the Autotune again. After a restart of the device, the error will be reset.
The sensor, the internal memory or the device is defective.	→ Contact the manufacturer, because maintenance is needed.
No proper connection to the PLC.	<ul style="list-style-type: none"> → Check the wiring. → Check the status of the PLC.

10.2 Status indicator is orange

MFM Analogue

Cause	Solution
A calibration procedure is in progress.	→ Wait until the calibration procedure is completed.

MFM Industrial Ethernet

Cause	Solution
A calibration procedure is in progress.	→ Wait until the calibration procedure is completed.
PROFINET: PLC is in Stop mode	→ Activate the PLC.

MFM RS485/Modbus RTU

Cause	Solution
A calibration procedure is in progress.	→ Wait until the calibration procedure is completed.

MFC Analogue

Cause	Solution
A calibration procedure is in progress.	→ Wait until the calibration procedure is completed.
The Autotune is in progress.	→ Wait until the Autotune is completed.
The operation mode of the device is set to Open-loop control mode , Manual set-point value or Analyze system .	→ Refer to Choose the source that gives the set-point value [▶ 45]

MFC Industrial Ethernet

Cause	Solution
A calibration procedure is in progress.	→ Wait until the calibration procedure is completed.
The Autotune is in progress.	→ Wait until the Autotune is completed.
The operation mode of the device is set to Open-loop control mode , Manual set-point value or Analyze system .	→ Refer to Choose the source that gives the set-point value [▶ 45]
PROFINET: PLC is in Stop mode	→ Activate the PLC.

MFC RS485/Modbus RTU

Cause	Solution
A calibration procedure is in progress.	→ Wait until the calibration procedure is completed.
The Autotune is in progress.	→ Wait until the Autotune is completed.
The operation mode of the device is set to Open-loop control mode , Manual set-point value or Analyze system .	→ Refer to Choose the source that gives the set-point value [▶ 45]

10.3 Status indicator is yellow

MFM Analogue

Cause	Solution
<p>One of the following values is out of specification. The sensor or the device can be damaged.</p> <ul style="list-style-type: none"> ■ the medium temperature ■ the device temperature ■ the supply voltage 	<p>→ Operate the device within the specifications. If the status indicator is still yellow, then send the device back to Bürkert.</p>

MFM Industrial Ethernet

Cause	Solution
<p>One of the following values is out of specification. The sensor or the device can be damaged.</p> <ul style="list-style-type: none"> ■ the medium temperature ■ the device temperature ■ the supply voltage 	<p>→ Operate the device within the specifications. If the status indicator is still yellow, then send the device back to Bürkert.</p>
<p>A change of the Ethernet protocol is in progress.</p>	<p>→ Wait until the change of protocol is completed. It can take up to 1 minute.</p>

MFM RS485/Modbus RTU

Cause	Solution
<p>One of the following values is out of specification. The sensor or the device can be damaged.</p> <ul style="list-style-type: none"> ■ the medium temperature ■ the device temperature ■ the supply voltage 	<p>→ Operate the device within the specifications. If the status indicator is still yellow, then send the device back to Bürkert.</p>

MFC Analogue

Cause	Solution
<p>One of the following values is out of specification. The sensor or the device can be damaged.</p> <ul style="list-style-type: none"> ■ the medium temperature ■ the device temperature ■ the supply voltage 	<p>→ Operate the device within the specifications. If the status indicator is still yellow, then send the device back to Bürkert.</p>

Cause	Solution
The set-point position for the actuator has (almost) reached 100%. The set-point value cannot be reached.	<ul style="list-style-type: none"> ➔ Increase the inlet pressure or decrease the outlet pressure. ➔ If the pressure drop in the pipe is too high, then reduce the pressure drop. ➔ If the filters that are installed in the pipe are dirty, then clean the filters.

MFC Industrial Ethernet

Cause	Solution
<p>One of the following values is out of specification. The sensor or the device can be damaged.</p> <ul style="list-style-type: none"> ■ the medium temperature ■ the device temperature ■ the supply voltage 	➔ Operate the device within the specifications. If the status indicator is still yellow, then send the device back to Bürkert.
A change of the Ethernet protocol is in progress.	➔ Wait until the change of protocol is completed. It can take up to 1 minute.
The set-point position for the actuator has (almost) reached 100%. The set-point value cannot be reached.	<ul style="list-style-type: none"> ➔ Increase the inlet pressure or decrease the outlet pressure. ➔ If the pressure drop in the pipe is too high, then reduce the pressure drop. ➔ If the filters that are installed in the pipe are dirty, then clean the filters.

MFC RS485/Modbus RTU

Cause	Solution
<p>One of the following values is out of specification. The sensor or the device can be damaged.</p> <ul style="list-style-type: none"> ■ the medium temperature ■ the device temperature ■ the supply voltage 	➔ Operate the device within the specifications. If the status indicator is still yellow, then send the device back to Bürkert.
The set-point position for the actuator has (almost) reached 100%. The set-point value cannot be reached.	<ul style="list-style-type: none"> ➔ Increase the inlet pressure or decrease the outlet pressure. ➔ If the pressure drop in the pipe is too high, then reduce the pressure drop. ➔ If the filters that are installed in the pipe are dirty, then clean the filters.

10.4 Status indicator is blue

Cause	Solution
Error in the internal memory.	➔ Contact the manufacturer, because maintenance is needed.

10.5 Status indicator is off

Cause	Solution
The device is not energised.	<ul style="list-style-type: none"> → Make sure that the device is correctly wired. → Make sure that the voltage supply is 24 V DC. → Make sure that the power supply source is working properly.

10.6 Status indicator goes out periodically

Cause	Solution
The power supply is intermittently dropping and the device restarts.	→ Use a power supply with sufficient power output.
The voltage drop in the connecting cable is too high.	→ Increase the cross-section of the cable and reduce the cable length.

10.7 Replacement device adopts none of the values from the defective device

Cause	Solution
The article number of the replacement device is different from the article number of the defective device.	→ Use a replacement device that has the same article number than the defective device. Values can only be transferred between devices with the same article numbers.
The memory card is defective. The device could not write any values to the memory card.	→ Replace the memory card. Refer to Replace the memory card [▶ 48]

10.8 Replacement device does not adopt all of the values from the defective device

Cause	Solution
The device description of the replacement device is different from the device structure of the defective device. Only the existing values of the defective device can be adopted by the replacement device.	→ Use the Bürkert Communicator to configure the new values of the replacement device.

10.9 No mass flow rate

MFM

Cause	Solution
The pipes are too large or not yet fully vented.	<ul style="list-style-type: none"> → Vent the pipes. → Change the pipe diameter.

Cause	Solution
The flow-rate value is below the cut-off limit.	→ If the cut-off limit is too high, decrease the value of the cut-off limit. Refer to Cut-off

MFC

Cause	Solution
The device is not in the normal operation mode, refer to Operation modes [▶ 42] . The device is possibly running one of the functions described in Choose the source that gives the set-point value [▶ 45]	→ If the device is not running one of the functions described in Choose the source that gives the set-point value [▶ 45] , then check the other possible causes of the problem.
The pipes are too large or not yet fully vented.	→ Vent the pipes. → Change the pipe diameter.
The flow-rate value is below the cut-off limit.	→ If the cut-off limit is too high, decrease the value of the cut-off limit. Refer to Cut-off
The set-point value is lower than the zero-point shut-off limit.	→ Increase the set-point value until it is higher than 2% of the nominal flow rate.

10.10 Unstable measured value

MFM

Cause	Solution
Functional earth (FE) is not connected properly.	→ To connect the functional earth, use a green-and-yellow cable that is as short as possible. And the cable cross-section must be at least equal to the cross section of the power-supply cable. Refer to Connect the functional earth [▶ 37]

MFC

Cause	Solution
Functional earth (FE) is not connected properly.	→ To connect the functional earth, use a green-and-yellow cable that is as short as possible. And the cable cross-section must be at least equal to the cross section of the power-supply cable. Refer to Connect the functional earth [▶ 37]
The residual ripple on the voltage supply is too high.	→ Use a supply voltage that conforms to the technical data given in Technical data [▶ 17]
The device must compensate for irregularities in an unstable pressure supply caused, for example, by pumps.	→ Install a suitable pressure regulator in front of the device. → Install a buffer tank to absorb the pressure fluctuations.

Cause	Solution
The controller is unstable.	→ Run the Autotune function to adapt to the operating conditions. Refer to Optimise the closed-loop control parameters [▶ 44]

10.11 Set-point value at 0 %, but medium still flows

MFC Analogue

The operating mode of the device is set to Open-loop control mode , and the actuator is open because the digital input triggers the opening of the actuator.	→ Either set the MFC to the normal operating mode. Refer to Normal operating mode (MFC) and to Choose the source that gives the set-point value [▶ 45] . Or, check the operation of the digital input. Refer to Digital input
The operating pressure is above the tight sealing pressure of the control valve.	→ Reduce the operating pressure. → To eliminate the defect, return the device to the manufacturer.
The connected actuator is a proportional valve and the operating pressure is above the tight sealing pressure of the proportional valve.	→ Reduce the operating pressure. → To eliminate the defect, return the device to the manufacturer

MFC Industrial Ethernet

The operating pressure is above the tight sealing pressure of the control valve.	→ Reduce the operating pressure. → To eliminate the defect, return the device to the manufacturer.
The connected actuator is a proportional valve and the operating pressure is above the tight sealing pressure of the proportional valve.	→ Reduce the operating pressure. → To eliminate the defect, return the device to the manufacturer

MFC RS485/Modbus RTU

The operating pressure is above the tight sealing pressure of the control valve.	→ Reduce the operating pressure. → To eliminate the defect, return the device to the manufacturer.
The connected actuator is a proportional valve and the operating pressure is above the tight sealing pressure of the proportional valve.	→ Reduce the operating pressure. → To eliminate the defect, return the device to the manufacturer

10.12 Set-point value at 0 %, no mass flow, but a non-zero mass flow rate is measured

MFC

Cause	Solution
The installation position of the device is incorrect.	<ul style="list-style-type: none"> → Install the device as recommended in Medium connection [▶ 25] → Run the Autotune function to adapt to the operating conditions. → Perform a zero point adjustment described in Zero point adjustment [▶ 41]
The medium is different from the medium specified during the calibration.	→ Use the specified medium or send the device to the manufacturer for calibration with the new medium.

10.13 Set-point value is not reached

MFC

Cause	Solution
The mesh filter is clogged.	<ul style="list-style-type: none"> → Clean or replace the mesh filter. → Run the Autotune function to adapt to the operating conditions.
The inlet pressure is too low.	<ul style="list-style-type: none"> → Increase the inlet pressure to the calibration pressure value. → Make sure that the pipe diameters and the pipe lengths are adapted.
The outlet pressure is too high.	<ul style="list-style-type: none"> → Make sure that the pipe diameters and the pipe lengths are adapted. → If the medium connection pipes after the device are dirty, then clean them.

10.14 Network status indicator

LED indicator	Meaning	Action
Link/Act-LED (green) fast blinking	Connection to the parent protocol layer is established.	-
Link/Act-LED (green) slow blinking (directly after restart)	Connection to the protocol layer is searched.	-
Link/Act-LED (green) slow blinking (20 s after restart)	No connection to the parent protocol layer.	→ Check the cable.
Link/Act-LED (green) is OFF.	No connection to the network.	→ Check the cable.
Link-LED (yellow) is ON	Connection to the network is established.	-

LED indicator	Meaning	Action
Link LED (yellow) is not lit	Not connected to network.	➔ Check cable.

Tab. 18: Meaning of the LED indicator

11 SPARE PARTS AND ACCESSORIES

CAUTION!

Risk of injury, property damage due to incorrect parts.

Incorrect options and unsuitable spare parts can cause injuries to people and damage to the appliance and its surroundings.

→ Only use original options and original spare parts from Bürkert.



For any questions, contact Bürkert.

11.1 Electrical accessories

→ For further accessories, refer to the data sheet.

Industrial Ethernet variant

Item	Article number
USB-büS-interface set, without power supply	772 551
Memory card	On request

Analogue variant

Item	Article number
USB-büS-interface set, without power supply	772 551
Memory card	On request
D-sub DE-9 female connector with 5 m cable, with stripped end	580 882
D-sub DE-9 female connector with 10 m cable, with stripped end	580 883

MFC RS485/Modbus RTU

Item	Article number
USB-büS-interface set, without power supply	772 551
Memory card	On request
D-sub DE-9 female connector with 5 m cable, with stripped end	580 882
D-sub DE-9 female connector with 10 m cable, with stripped end	580 883

11.2 Compression fittings for a device with G-internal-threaded connections

The threaded pipe-connection plates of the device obey standard DIN ISO 228/1. If the pipe fittings are not delivered with the device, then choose pipe fittings that are adapted to the medium connection of the device. Also order the seal depending on the medium connection and the pipe diameter.

Device internal- threaded connection in accordance with DIN ISO 228/1	Pipe diameter	Article number	
		Stainless steel compression-fitting	Seal (1 piece)
G 1/4	6 mm	901538	901575 (Copper)
G 1/4	8 mm	901540	
G 1/4	1/4"	901551	901579 (Rubber steel)
G 1/4	3/8"	901553	

Tab. 19: Stainless steel compression fittings and related seals

11.3 Mesh filters

Item	Article number
Stainless steel mesh filter, different mesh sizes	On request

Tab. 20: Mesh filters

11.4 Additional software

Bürkert Communicator	Download from country.burkert.com
----------------------	---

Tab. 21: Documentation and software

12 UNINSTALLATION

12.1 Dismantling

- Relieve the medium pressure in the installation.
- Flush the device with a neutral medium (for example nitrogen)
- Relieve the flushing medium pressure in the installation.
- De-energise the device.
- Remove the electrical wiring.
- Disconnect the medium connections.
- Remove the device.

13 LOGISTICS

13.1 Transport and storage

- Protect the device against moisture and dirt in the original packaging during transportation and storage.
- Avoid UV radiation and direct sunlight.
- Protect connections from damage with protective caps.
- Observe permitted storage temperature.
- Remove cables, connectors, external filters and installation equipment.
- Clean and vent contaminated devices.

13.2 Return



No work or tests will be carried out on the device until a valid Contamination Declaration has been received.

- To return a used device to Bürkert, contact your Bürkert sales office. A return number is required.

13.3 Disposal

Environmentally friendly disposal



- Follow national regulations regarding disposal and the environment.
- Collect electrical and electronic devices separately and dispose of them as special waste.

Further information at country.burkert.com