

Type 8653 AirLINE Field

Field module for pneumatic systems



Operating Instructions

We reserve the right to make technical changes without notice.

© Bürkert Werke GmbH & Co. KG, 2019-2025

Operating Instructions 2504/06_EUen_00810656 / Original DE

AirLINE Field Type 8653

CONTENTS

1	OPERATING INSTRUCTIONS	5
1.1	Symbols.....	5
1.2	Definition of terms.....	6
2	INTENDED USE	7
3	BASIC SAFETY INSTRUCTIONS	8
4	GENERAL INFORMATION.....	10
4.1	Contact address.....	10
4.2	Warranty	10
4.3	Information on the Internet.....	10
5	PRODUCT DESCRIPTION.....	11
5.1	Intended application range.....	11
5.2	Characteristics	11
5.3	Structure.....	11
6	TECHNICAL DATA	14
6.1	Conformity.....	14
6.2	Standards.....	14
6.3	Operating conditions	14
6.4	General technical data.....	15
6.4.1	Pneumatic slide valve type 6534	15
6.4.2	Pilot pressure diagram.....	15
6.5	Circuit function (CF).....	16
6.6	Type labels (device labelling).....	17
6.6.1	Type label UL (example).....	17
7	ASSEMBLY	18
7.1	Fastening types.....	18
7.2	Assembly on wall	18
7.2.1	Assembly on wall using the bracket	19
7.2.2	Assembly on wall using the lateral fastening holes	19
7.3	Assembly on standard rail	20
8	ELECTRICAL CONNECTION.....	22
8.1	Assignment of circular plug M12, 5-pole.....	22
8.1.1	büS/CANopen variant.....	22
8.1.2	IO-Link variant	22
8.2	Connecting the functional earth.....	23
8.2.1	Connecting the functional earth for assembly on wall	23

8.2.2	Connecting the functional earth for assembly on standard rail	24
9	PNEUMATIC CONNECTION.....	25
9.1	Assignment of the pneumatic connections	25
10	CONFIGURATION WITH BÜRKERT COMMUNICATOR.....	26
10.1	User interface of the Bürkert Communicator.....	26
10.2	Establishing a connection between the device and the Bürkert Communicator.....	27
10.3	Create the base settings of the field module.....	27
10.4	Menu structure	28
10.4.1	Configuration area „Unit 1“	28
10.4.2	Configuration area „General settings“	29
11	CONFIGURATION VIA FIELDBUS.....	31
11.1	Cabling of büS/CANopen networks	31
11.2	Start-up file.....	32
11.3	Bit-by-bit compilation of the inputs and outputs	32
11.3.1	Examples of bit-by-bit allocation of valve units.....	32
12	START-UP	33
12.1	Starting up via manual override	33
12.1.1	Additional element “MO locking”.....	34
12.2	Marking the valve slots	35
13	OPERATION.....	36
13.1	Display elements.....	36
13.2	Display.....	36
13.2.1	Display views	36
13.3	LED status display	38
14	MAINTENANCE, TROUBLESHOOTING.....	39
14.1	Troubleshooting	39
14.2	Fault messages LCD	41
15	REMOVAL	42
16	ACCESSORIES	43
17	PACKAGING, TRANSPORT.....	46
18	STORAGE	46
19	DISPOSAL	46

1 OPERATING INSTRUCTIONS

The operating instructions describe the entire life cycle of the device.

→ Keep these instructions ready to hand at the operation site.

Important safety information!

- ▶ Carefully read these instructions.
- ▶ Observe in particular the safety instructions, intended use, and the operating conditions.
- ▶ Persons who work on the device must read and understand these instructions.

1.1 Symbols



DANGER

Warns of an immediate danger.

- ▶ Failure to observe the warning will result in fatal or serious injuries.



WARNING

Warns of a potentially dangerous situation.

- ▶ Failure to observe the warning may result in serious or fatal injuries.



CAUTION

Warns of a possible danger.

- ▶ Failure to observe the warning may result in moderate or minor injuries.

NOTE

Warns of damage to property.

- ▶ Failure to observe the warning may result in damage to the device or other equipment.



Indicates important additional information, tips and recommendations.



Refers to information in these operating instructions or in other documentation.



Highlights instructions to avoid a danger.



Highlights a procedure which you must carry out.



Highlights a result.



Symbol for software interface texts.

1.2 Definition of terms

Term	In these instructions representative for
Device, field module	AirLINE Field Type 8653 field module
Valve	Pneumatic slide valve integrated in the field module
Actuator, process valve, pneumatic cylinder, pneumatic actuator, pneumatic components	Pneumatic consumer that is controlled by the field module
büS	Bürkert system bus, a communication bus developed by Bürkert based on the CANopen protocol

2 INTENDED USE

The AirLINE Field Type 8653 field module is designed to control and record the switching statuses of pneumatically actuated process valves, pneumatic cylinders and other pneumatically actuated actuators directly in the process environment.

- ▶ Use the device for its intended purpose only. Non-intended use of the device may be dangerous to people, nearby equipment and the environment.
- ▶ Do not use the device in the potentially explosive atmosphere.
- ▶ The prerequisites for safe and efficient operation are correct transport, storage, assembly, installation, start-up, operation, and maintenance.
- ▶ When using the device, observe the permitted data, operating conditions and application conditions. This information can be found in the contractual documents, the operating instructions and on the type label.
- ▶ Use the device only in conjunction with third-party devices and components recommended and authorised by Bürkert.
- ▶ Make sure the device is in a technically flawless state before use.



The device is intended only for use in industrial areas.

The device is not suitable for use in applications where there is a risk to life and limb.

3 BASIC SAFETY INSTRUCTIONS

These safety instructions do not consider any contingencies or incidents which occur during assembly, operation and maintenance. The operator is responsible for observing the location-specific safety regulations, also with reference to the personnel.



Risk of injury due to high pressure and uncontrolled movement of the actuators.

- ▶ Before working on the device or system, secure the actuators against moving.
- ▶ Before working on the device or system, switch off the pressure. Vent or drain lines.

Risk of injury from electric shock.

- ▶ Before working on the device or system, switch off the power supply. Secure against reactivation.
- ▶ Observe applicable accident prevention and safety regulations for electrical equipment.

Risk of burns due to hot device parts.

- ▶ Keep the device away from highly flammable substances and media.

Risk of injury due to improper installation and maintenance.

- ▶ Only trained technicians may perform installation and maintenance work.
- ▶ Perform installation and maintenance with suitable tools only.

Risk of injury due to unintentional activation and uncontrolled start-up of the device and system.

- ▶ Secure the device and system to prevent unintentional activation.
- ▶ Ensure that the system does not start up in an uncontrolled manner.

General hazardous situations.

To prevent injury, observe the following:

- ▶ Install the device according to the regulations applicable in the country.
- ▶ Do not supply aggressive or flammable media to the media connections of the device.
- ▶ Do not supply liquids to the media connections of the device.
- ▶ After the process is interrupted, restart in a controlled manner.
Observe sequence:
 1. Connect the power supply.
 2. Connect the pneumatic supply (with an external pressure supply, initially the external auxiliary pilot air [X / 12/14] and then the medium pressure [P / 1]).
- ▶ Do not make any changes to the device.
- ▶ Do not subject the device to mechanical loads.
- ▶ Observe the general rules of technology.

NOTE

Electrostatically sensitive components and modules.

The device contains electronic components which are susceptible to electrostatic discharge (ESD). Components which come into contact with electrostatically charged people or objects are at risk. In the worst case scenario, these components will be destroyed immediately or will fail after start-up.

- ▶ Meet the requirements specified by EN 61340-5-1 to minimise or avoid the possibility of damage caused by sudden electrostatic discharge.
- ▶ Do not touch electronic components when the supply voltage is connected.

4 GENERAL INFORMATION

4.1 Contact address

Germany

Bürkert Fluid Control Systems
Sales Center
Christian-Bürkert-Strasse 13–17
D-74653 Ingelfingen
Phone +49 (0) 7940 - 10 91 111
Fax +49 (0) 7940 - 10 91 448
E-mail: info@burkert.com

International

The contact addresses can be found on the last pages of the printed Quickstart.

And also on the Internet at: www.burkert.com

4.2 Warranty

The warranty is only valid if the device is used as intended in accordance with the specified application conditions.

4.3 Information on the Internet

The operating instructions and data sheets for Bürkert products can be found on the Internet at:

www.burkert.com

5 PRODUCT DESCRIPTION

The AirLINE Field Type 8653 field module is designed for decentralised use in the process environment. The device is simple to install and increases process safety due to the integrated monitoring and diagnostic functions.

The body with IP65/67 protection eliminates the need for further protective housing such as a control cabinet.

5.1 Intended application range

The AirLINE Field Type 8653 field module is designed to control and record the switching statuses of pneumatically actuated process valves, pneumatic cylinders and other pneumatically actuated actuators directly in the process environment.

5.2 Characteristics

- Earthed by special bracket
- Installation without control cabinets possible
- Degree of protection IP65/67
- Integrated check valves
- LED for visual feedback of device status
- Two-line LCD screen for displaying information, warnings, faults
- Switching cycle display and predefined warning thresholds
- Manual override as non-locking and locking mechanism
- Redundant ring topology with Media Redundancy Protocol (MRP) or Device Level Ring (DLR)
- Optional connection to Bürkert's Efficient Device Integration Platform (EDIP):
Configuration and parameterization with the universal software tool Bürkert Communicator

5.3 Structure

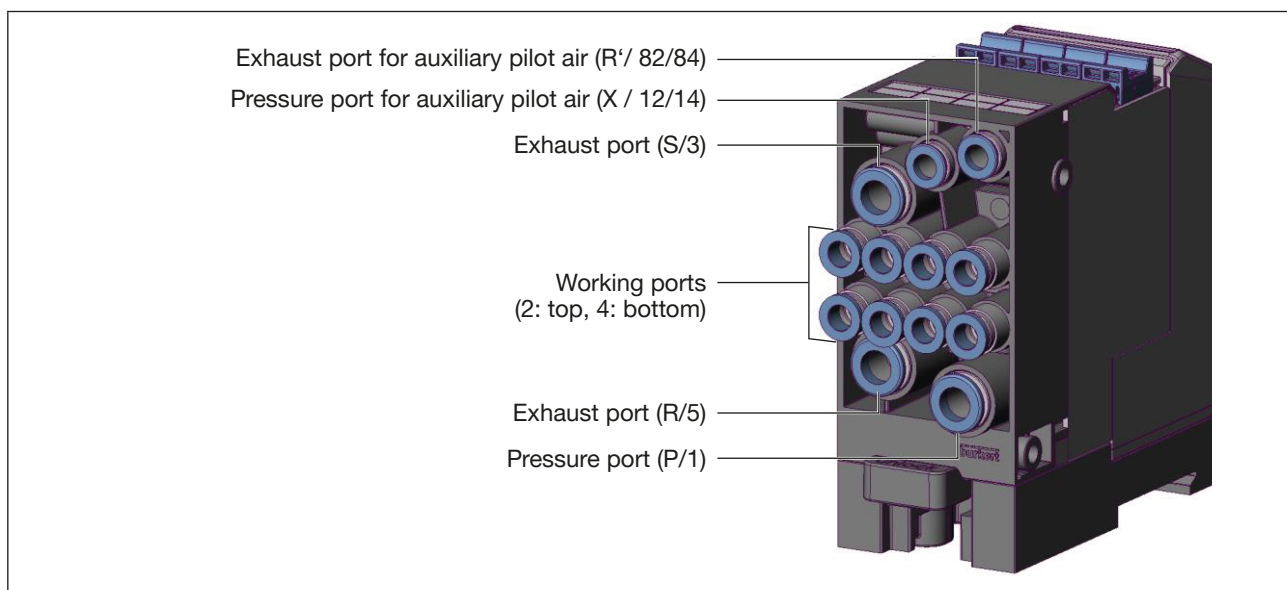

Fig. 1: Structure of AirLINE Field Type 8653 – view from below

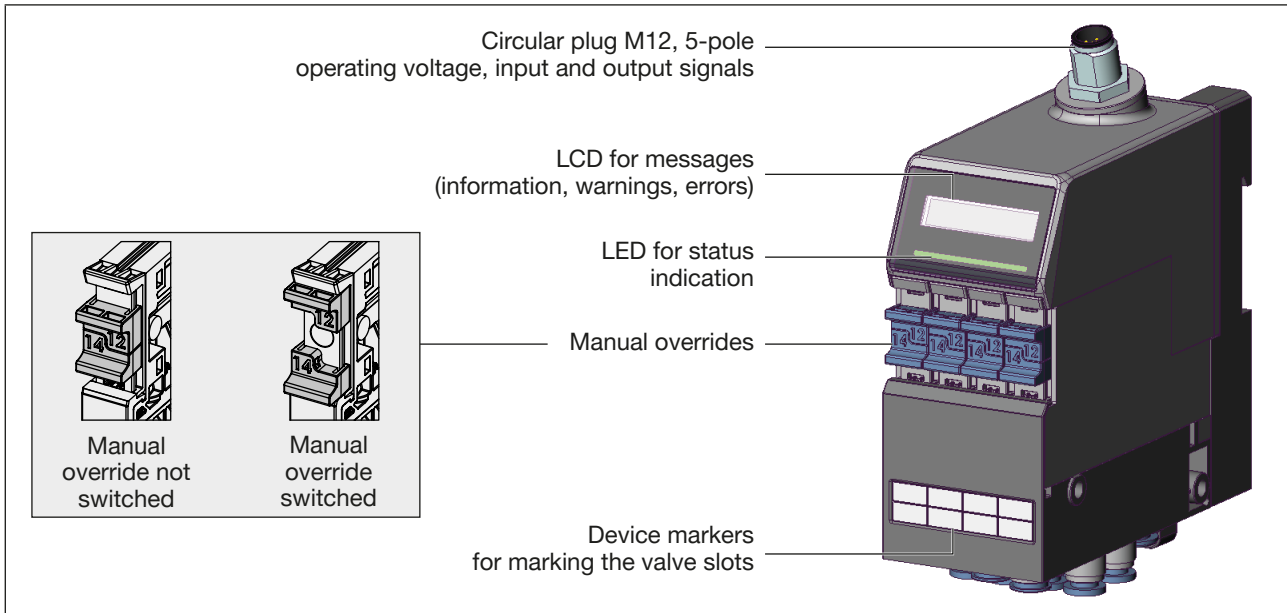

Fig. 2: Structure of AirLINE Field Type 8653 – view from front

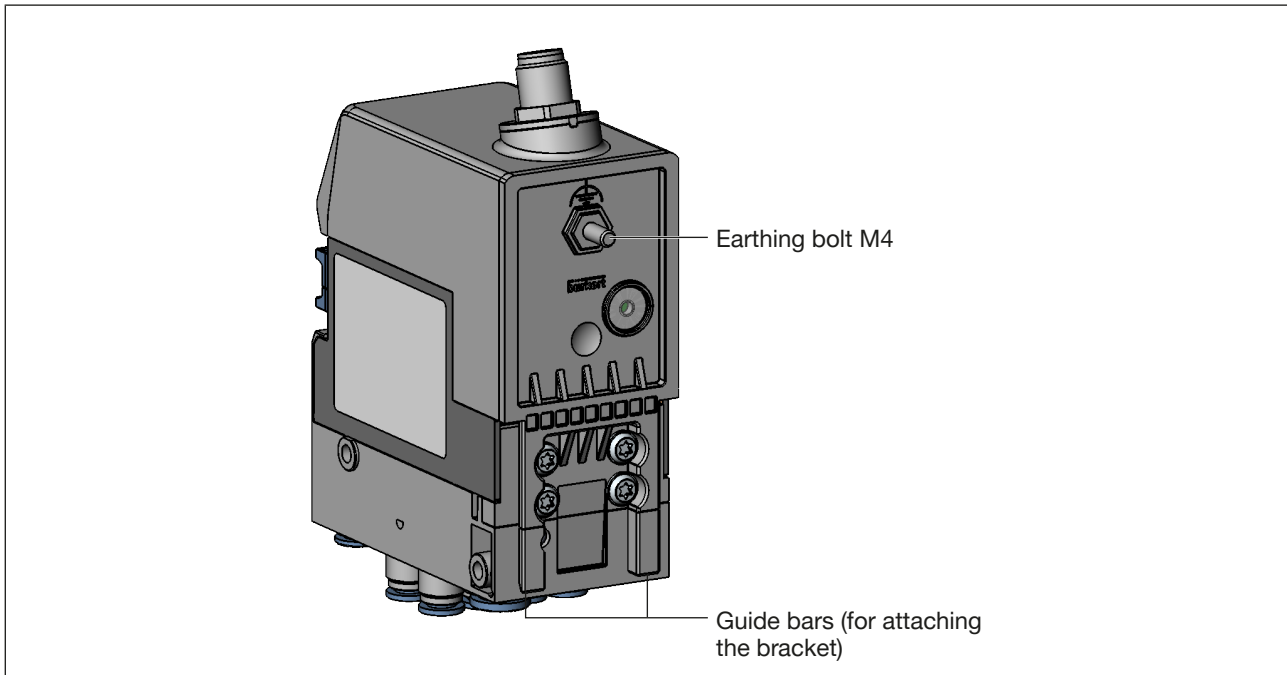

Fig. 3: Structure of AirLINE Field Type 8653 – view from behind (without bracket)

Bracket for assembly on wall or on standard rail

In the delivery condition, the device is locked to a bracket for assembly on wall or standard rail.

The bracket can be removed from the device for assembly purposes.

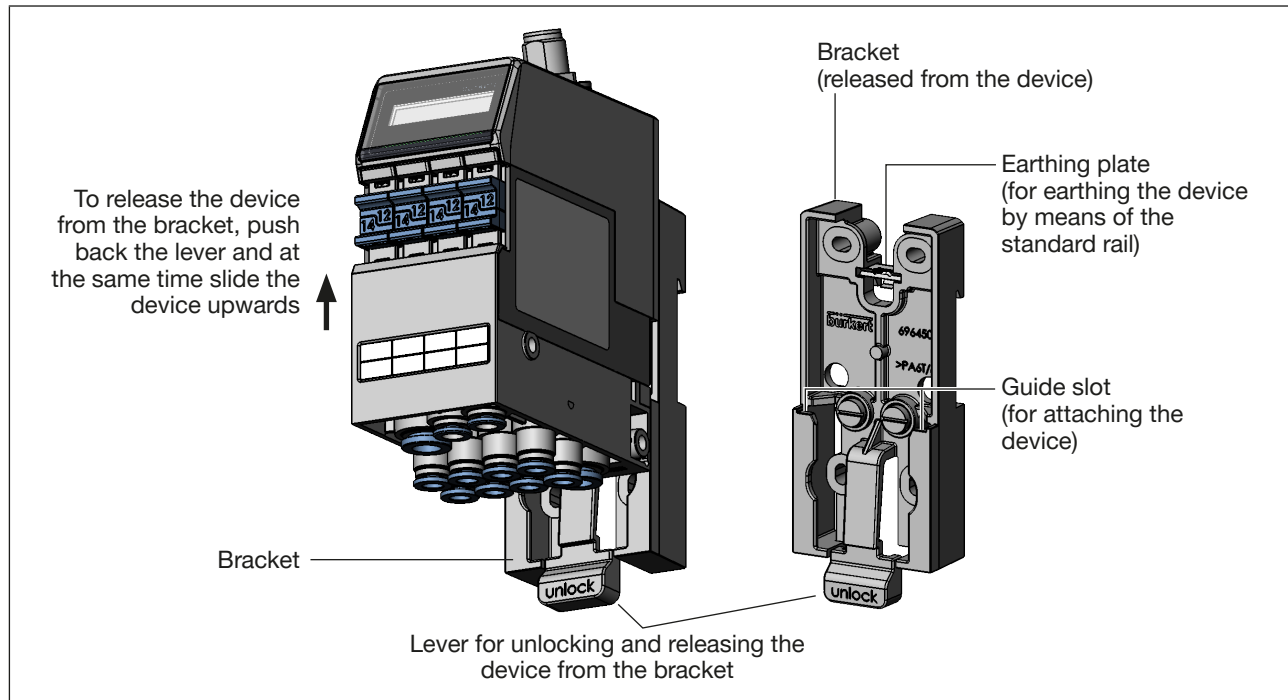

Fig. 4: Bracket for assembly on wall or on standard rail

6 TECHNICAL DATA

6.1 Conformity

The device conforms to the EU directives as per the EU Declaration of Conformity (if applicable).

6.2 Standards

The applied standards, which are used to demonstrate conformity with the directives, are listed in the EU type examination certificate and/or the EU Declaration of Conformity (if applicable).

6.3 Operating conditions

NOTE

► Use protective low voltage according to protection class 3 EN 61140, VDE 0140

Type of condition	permitted range
Ambient temperature	-10...+55 °C
Storage temperature	-10...+60 °C
Altitude	Restricted to max. 2000 m above sea level for UL approved versions
Compressed air quality	ISO 8573-1:2010, Class 7.4.4
Nominal operating mode	Continuous operation (100% duty cycle)
Maximum switching frequency	2.5 Hz
Operating voltage	24 V \pm 10% residual ripple at fieldbus interface 1 V _{ss} ¹
Protection class	3 in accordance with EN 61140, VDE 0140
Current consumption	≤ 400 mA

1) UL approved Versions must be supplied by one of the following:

a) Limited Energy Circuit (LEC) according to UL/ IEC 61010-1

b) Limited Power Source (LPS) according to UL/ IEC 60950

c) SELV/ PELV with UL Recognized Overcurrent Protection dimensioned according to UL/ IEC 61010-1 Table 18

d) NEC Class 2 power source

6.4 General technical data

Valve slots	4
Degree of protection	IP65/67 (not evaluated by UL)

6.4.1 Pneumatic slide valve type 6534

Circuit function (CF)	2 x C NC (normally closed) 2 x 3/2-way 2 x D NO (normally open) 2 x 3/2-way	H 5/2-way monostable Z 5/2-way bistable (on request)	L 5/3-way locked (on request) M 5/3-way pressurised (on request) N 5/3-way exhausted (on request)
Flow rate Q_{Nn}	Up to 310 l_N/min (see data sheet for exact flow rate values for the various circuit functions)		
Medium pressure*	0...8 bar		
Pilot pressure*	3...8 bar		
Electr. power before/ after power reduction	2 x 0.7 W / 2 x 0.175 W	0.7 W / 0.175 W	0.7 W / 0.175 W
Current before/after power reduction	2 x 29 mA / 2 x ≤ 10 mA	29 mA / ≤ 10 mA	

*) Observe pilot pressure diagram!

6.4.2 Pilot pressure diagram

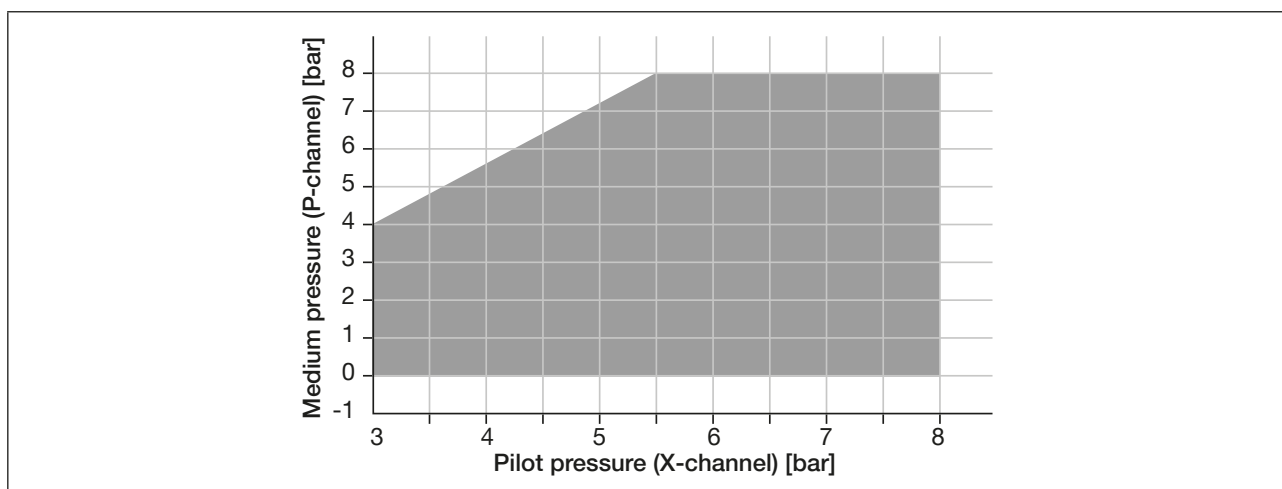

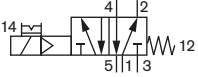
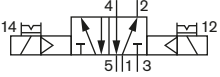
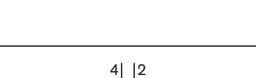
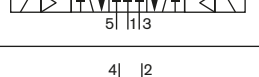
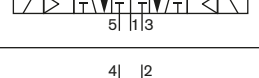

Fig. 5: Pilot pressure diagram for pneumatic slide valve Type 6534

6.5 Circuit function (CF)

Circuit function	Icon in accordance with ISO 1219-1	Description
2 x CFC		In idle position, port 2 and port 4 exhausted.
2 x CFD		In idle position, port 2 and port 4 vented.
CFH		In idle position, pressure port 1 with port 2 connected, port 4 exhausted.
CFZ (on request)		5/2-way bistable valve; depending on the switch position either port 2 vented and port 4 exhausted or port 2 exhausted and port 4 vented.
CFL (on request)		In idle position, all ports locked.
CFM (on request)		In idle position, port 2 and port 4 pressurised.
CFN (on request)		In idle position, port 2 and port 4 de-energised.

6.6 Type labels (device labelling)

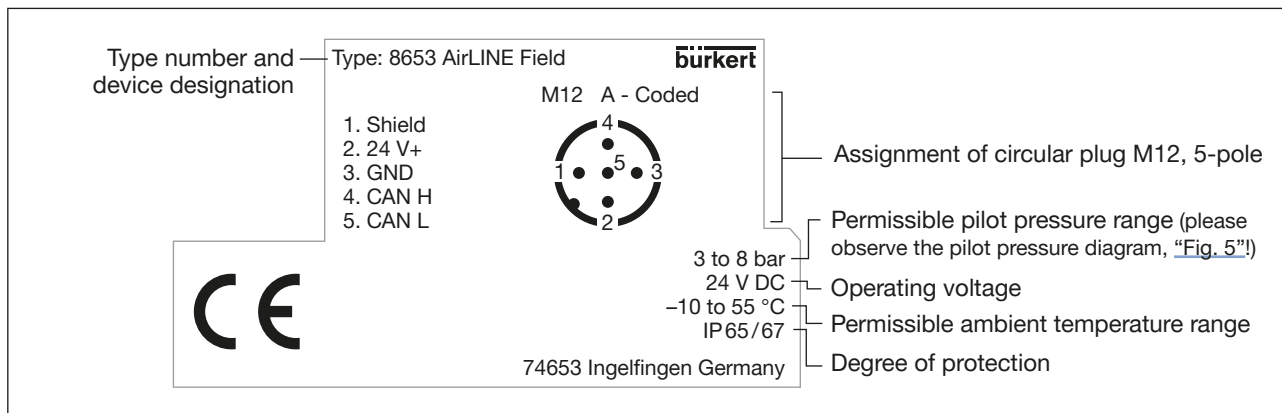

Fig. 6: Example of device labelling on the side of the device housing (büS/CANopen variant)

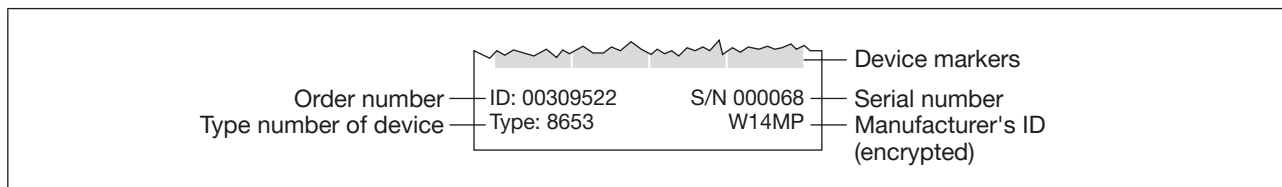

Fig. 7: Example of device labelling on the front surface of device housing

6.6.1 Type label UL (example)

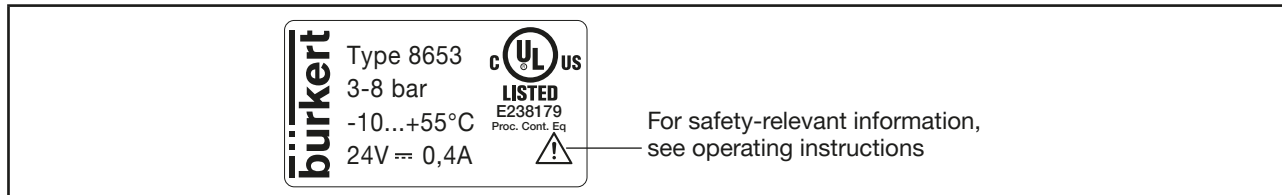

Fig. 8: Type label UL for field module type 8653

7 ASSEMBLY

WARNING

Risk of injury due to incorrect assembly.

- ▶ Assembly work should be carried out by fully trained personnel only.
- ▶ Use suitable tools to perform assembly work.

NOTE

Ensure degree of protection.

- ▶ If the device is mounted with the connections facing upwards: make sure that the exhaust ports are closed by a suitable silencer or that the exhaust air is discharged via a hose.



The AirLINE Field Type 8653 field module is supplied as a fully assembled device. If defects are discovered, the device must be replaced.

7.1 Fastening types

The body with IP65/67 protection eliminates the need for further protective housing such as a control cabinet.

The device can be mounted on the following types directly in the process environment:

- Assembly on wall using the bracket
- Assembly on wall using the lateral fastening holes
- Assembly on standard rail using the bracket

7.2 Assembly on wall

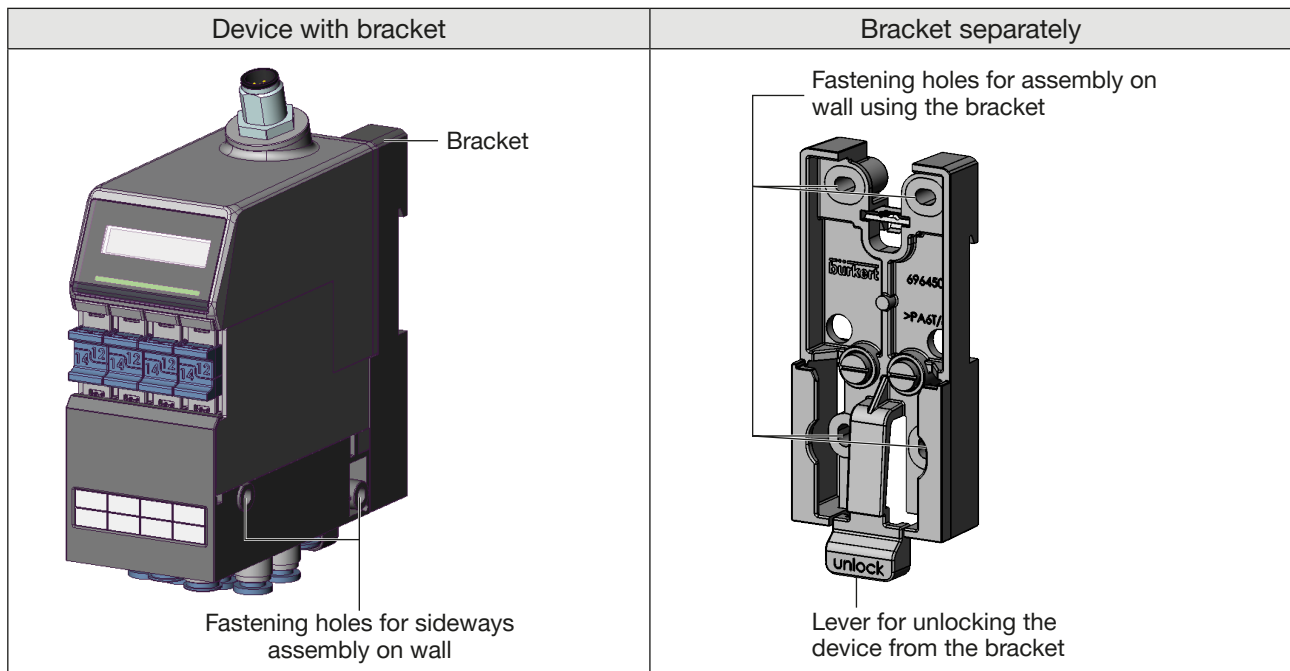

Fig. 9: Assembly on wall for AirLINE Field Type 8653 field module

7.2.1 Assembly on wall using the bracket



CAUTION

Risk of injury due to sharp edges.

The earthing plate on the bracket has sharp edges that can cause cuts.

- ▶ Wear suitable protective gloves.

Preparatory work

The bracket is connected to the device in the scope of delivery. For assembly on wall using the bracket, the device must be released from the bracket.

- Push back the lever for unlocking the device and at the same time pull the device upwards out of the bracket.

Assembly

-  Observe chapter [“Connecting the functional earth for assembly on wall”](#) on page 23.
- Securely attach the bracket using 4 suitable screws (e. g. M5 screws) to a suitable substrate (max. tightening torque 1.5 Nm for M5 screws).
- Slide the guide bars on the field module (see [“Fig. 3”](#)) from the top to the bottom into the guide slot of the bracket (see [“Fig. 4”](#)) until the locking mechanism engages audibly.

7.2.2 Assembly on wall using the lateral fastening holes

-  Observe chapter [“Connecting the functional earth for assembly on wall”](#) on page 23.
- Securely attach the field module using 2 suitable screws (e. g. M5 screws) to a suitable substrate (max. tightening torque 1.5 Nm for M5 screws).

7.3 Assembly on standard rail

! CAUTION

Risk of injury due to sharp edges.

The earthing plate on the bracket has sharp edges that can cause cuts.

► Wear suitable protective gloves.

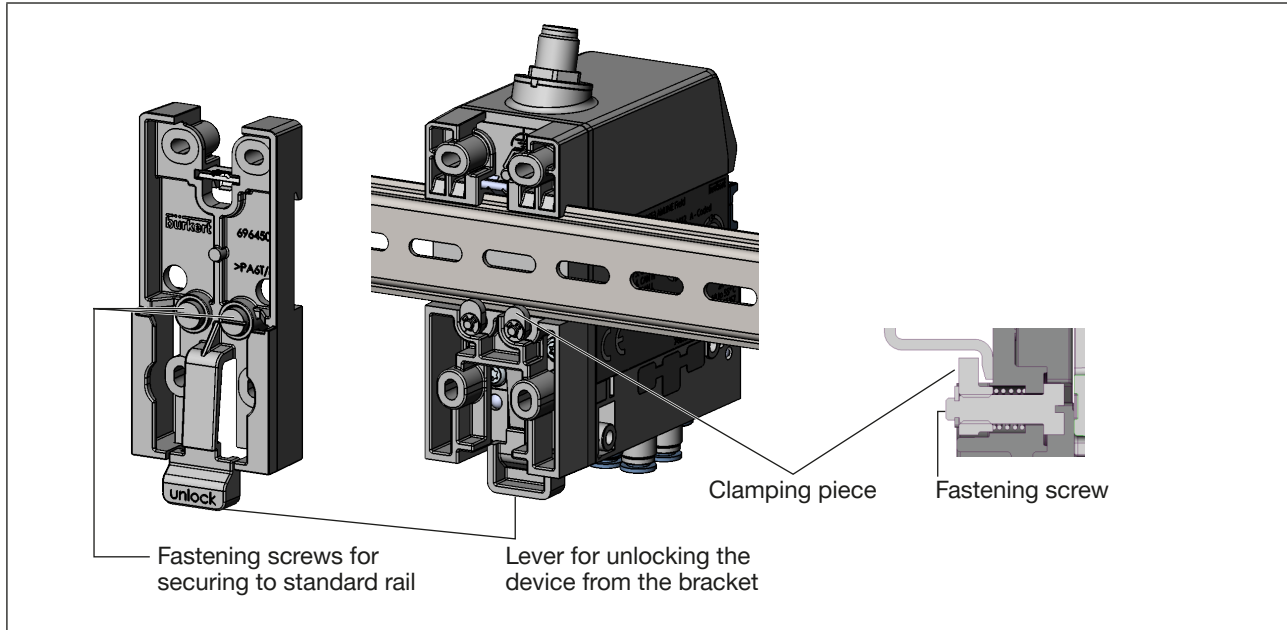

Fig. 10: Assembly on standard rail for AirLINE Field Type 8653 field module

Preparatory work

The bracket is connected to the device in the scope of delivery. For assembly on the standard rail, the device must be released from the bracket.

→ Push back the lever for unlocking the device and at the same time pull the device upwards out of the bracket.

Assembly

→ **!** Observe chapter [“Connecting the functional earth for assembly on standard rail”](#) on page 24.

→ Using a slotted-head screwdriver, carefully turn the fastening screws on the bracket all the way anticlockwise.

→ Position the bracket on the standard rail by tilting it upward slightly and then push it into position on the standard rail.

→ Using a slotted-head screwdriver, carefully turn the fastening screws on the bracket all the way clockwise.

The bracket is now secured to the standard rail by the clamping pieces.

→ Slide the guide bars on the field module (see [“Fig. 3”](#)) from the top to the bottom into the guide slot of the bracket (see [“Fig. 4”](#)) until the locking mechanism engages audibly.

Removal from the standard rail

- Push back the lever for unlocking the device and at the same time pull the device upwards out of the bracket.
- Using a slotted-head screwdriver, carefully turn the fastening screws on the bracket all the way anticlockwise.
- Tilt the bracket upward slightly and remove it from the standard rail.

8 ELECTRICAL CONNECTION

CAUTION

Risk of injury from electric shock.

- ▶ Before working on the device or system, switch off the power supply. Secure against reactivation.
- ▶ Observe applicable accident prevention and safety regulations for electrical equipment.

Risk of injury due to incorrect electrical connection work.

- ▶ The electrical connection work should be carried out by fully trained personnel only.
- ▶ Use suitable tools to establish the electrical connection.



Further information on cabling bÜS networks can be found under the following link:

[Guide for planning of bÜS networks](#)

NOTE

To ensure electromagnetic compatibility (EMC):

- ▶ Only use shielded cables.
- ▶ Connect the functional earth (see chapter “8.2” on page 23).

8.1 Assignment of circular plug M12, 5-pole

8.1.1 bÜS/CANopen variant

View of pins	Pin	Assignment
	1	Shielding
	2	Supply voltage 24 V \equiv
	3	GND
	4	CAN_H (bÜS connection)
	5	CAN_L (bÜS connection)

Table 1: Assignment of circular plug M12, 5-pole, A-coded, bÜS/CANopen variant

8.1.2 IO-Link variant

View of pins	Pin	Assignment
	1	L+ (24 V \equiv processor)
	2	P24 (24 V \equiv valve unit)
	3	L- (0 V GND processor)
	4	C/Q (IO-Link)
	5	N24 (0 V GND valve unit)

Table 2: Assignment of circular plug M12, 5-pole, A-coded, IO-Link variant, Port Class B

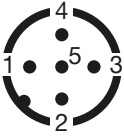
8.2 Connecting the functional earth

WARNING

Malfunctioning caused by electrostatic discharge.

Electrostatic discharge at the device may cause malfunctioning.

- ▶ Assembly on wall: Depending on the installation situation, use a **short cable with a large cross-section** to connect the device to the functional earth.
- ▶ Assembly on standard rail: Depending on the installation situation, use a **short cable with a large cross-section** to connect the standard rail to the functional earth.

Danger due to electromagnetic fields.

If the functional earth (FE) is not connected, the conditions of the EMC Law are not observed.

- ▶ Assembly on wall: Depending on the installation situation, use a **short cable with a large cross-section** to connect the device to the functional earth.
- ▶ Assembly on standard rail: Depending on the installation situation, use a **short cable with a large cross-section** to connect the standard rail to the functional earth.

8.2.1 Connecting the functional earth for assembly on wall

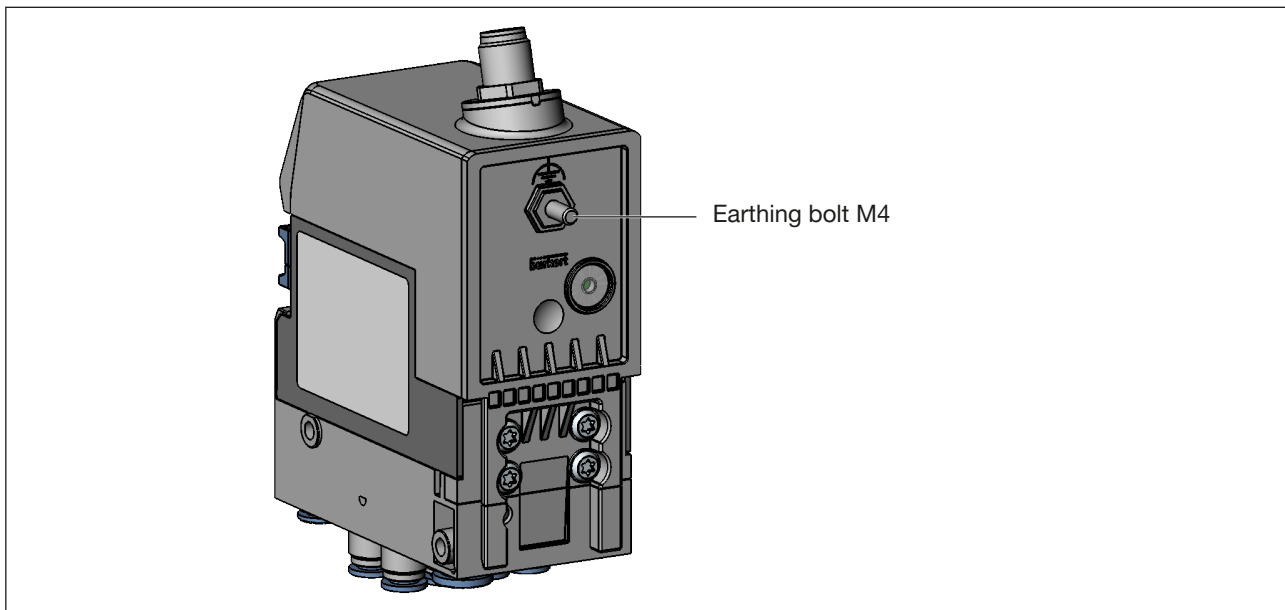

Fig. 11: Earthing bolt on the rear of the device (shown without the bracket)

→ Use a short cable with a large cross-section to connect the earthing bolt M4 to the functional earth.

8.2.2 Connecting the functional earth for assembly on standard rail

The earthing bolt on the device makes contact with an earthing plate that is integrated into the bracket. When the device is assembled on a standard rail, the earthing plate makes contact with the standard rail. As a result, the device is connected to the earth potential when it is clamped onto the earthed standard rail.

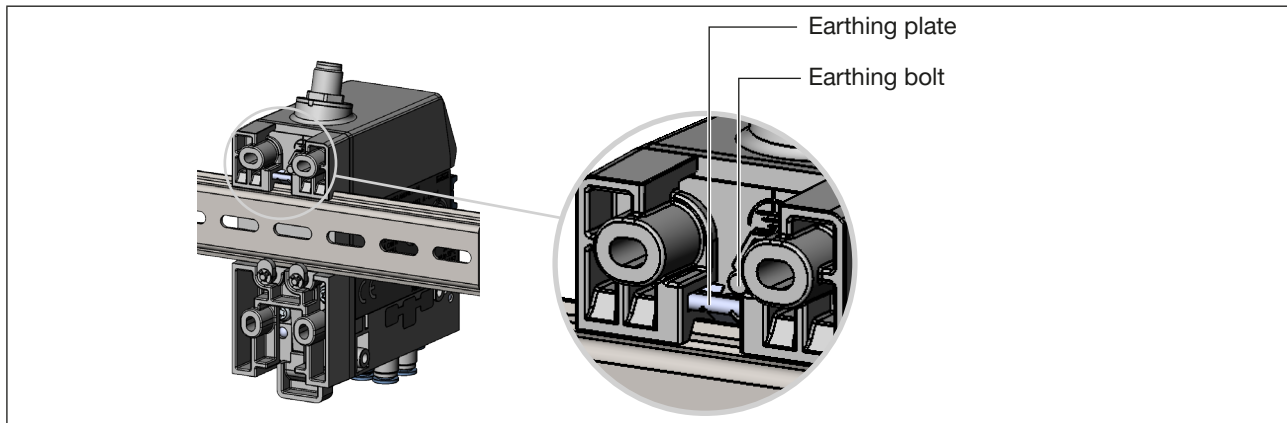

Fig. 12: Earthing by means of the standard rail

→ Use a short cable with a large cross-section to connect the standard rail to the functional earth.

9 PNEUMATIC CONNECTION

! DANGER

Risk of injury due to high pressure.

- ▶ Before working on the device or system, secure the actuators against moving.
- ▶ Before working on the device or system, switch off the pressure. Vent or drain lines.

Risk of injury due to incorrect pneumatic connection work.

- ▶ The pneumatic connection work should be carried out by fully trained personnel only.
- ▶ Use suitable tools to establish the pneumatic connection.

! The pressure port for auxiliary pilot air (X / 12/14) must always be connected.

9.1 Assignment of the pneumatic connections

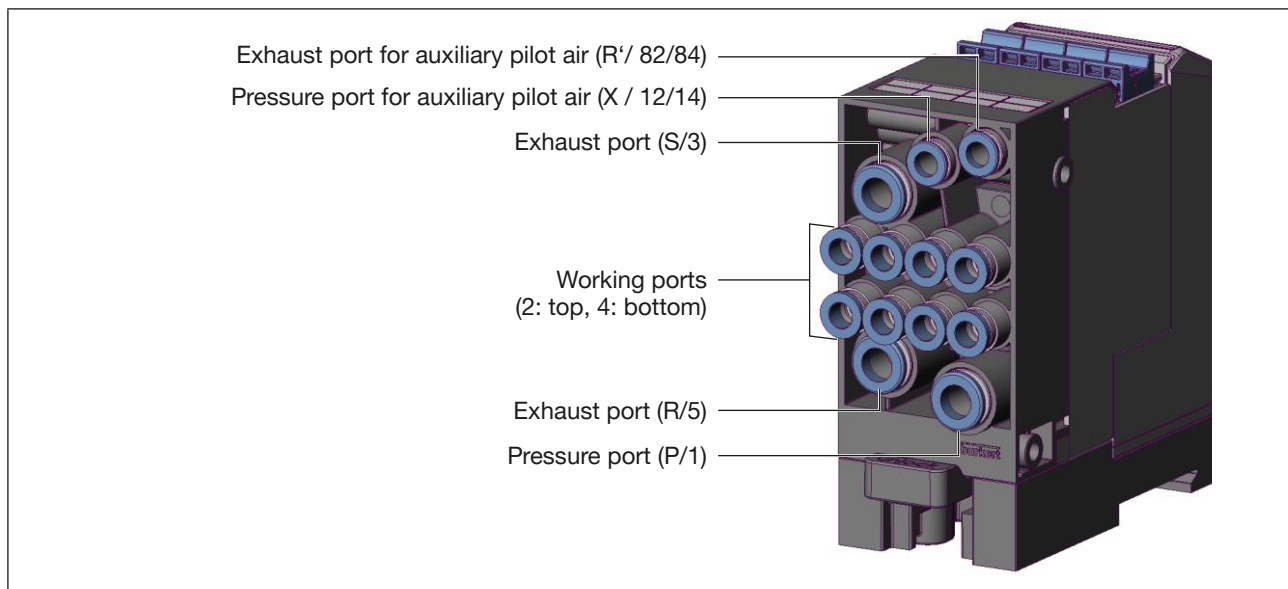

Fig. 13: Pneumatic connections of the field module

10 CONFIGURATION WITH BÜRKERT COMMUNICATOR

The device can be configured at a PC using the “Bürkert Communicator” software.

! The software can be downloaded free of charge from the Bürkert website. In addition to the software, the “USB-büS-interface”, available as an accessory, is required (see chapter “16 Accessories”).

i The operating instructions for the basic functions of the software can be found on the Bürkert website: www.burkert.com → Type 8920

10.1 User interface of the Bürkert Communicator

MAN 1000381061 ML Version: G Status: RL (released | freigegeben) printed: 30.04.2025

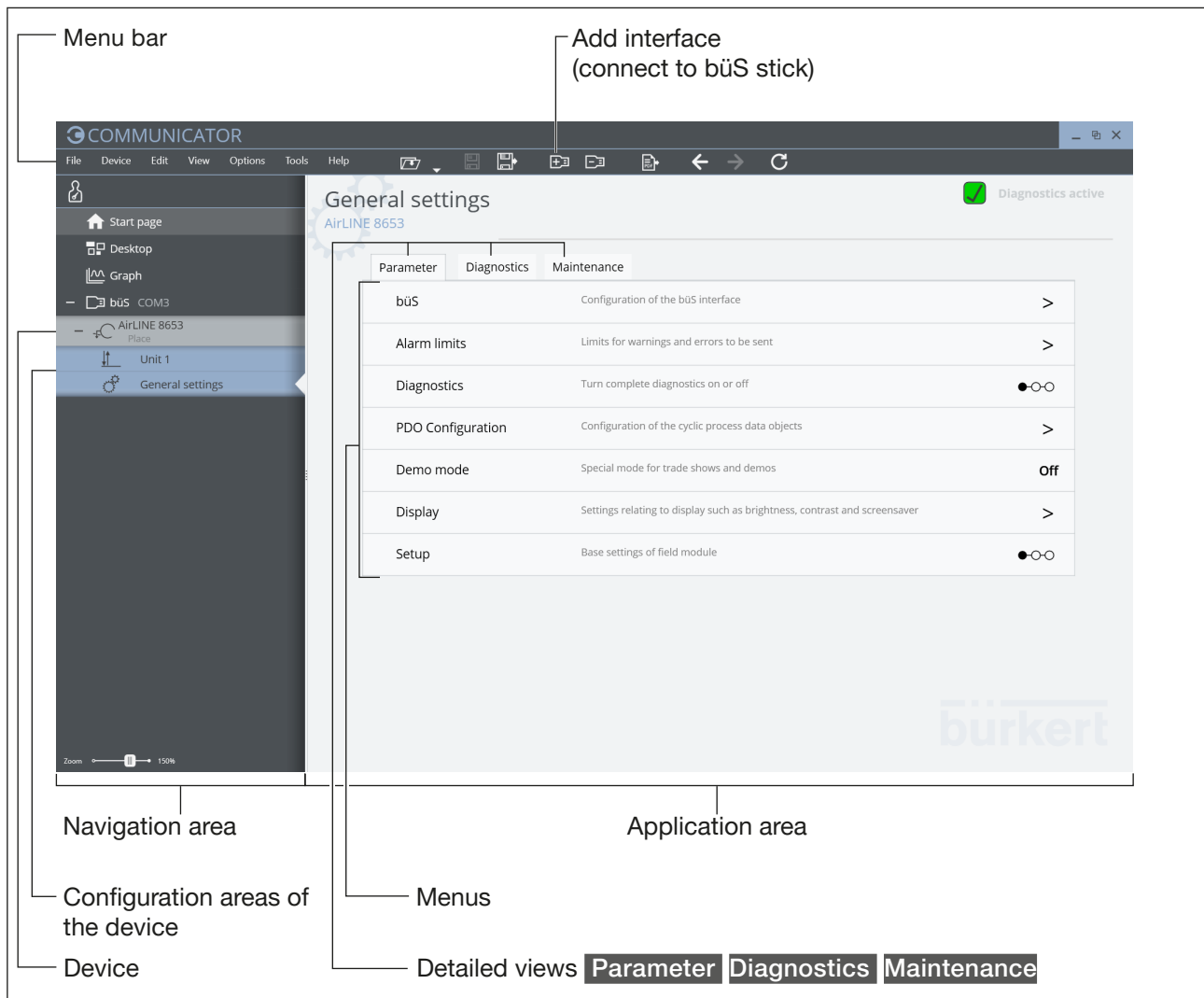



Fig. 14: User interface Bürkert Communicator

10.2 Establishing a connection between the device and the Bürkert Communicator

- Install the Bürkert Communicator software on the PC.
 - Set the load resistance (at the büS stick or external load resistance).
 - Use the büS stick to establish a connection between the device and the PC.
 - Start the Bürkert Communicator.
 - In the menu bar, click the icon  for **Add interface**.
 - Select **büS stick**. **Finish**.
-  A connection is established between the device and Bürkert Communicator. The device is displayed in the navigation area.

10.3 Create the base settings of the field module

- Click on the + in the navigation area in front of the device name; the configuration sections of the device will be displayed.
 - Select the configuration section **General settings**.
 - In the detailed application area **Parameters**, select the **Set-up** menu.
- A start-up wizard will guide you through the base settings of the device.

10.4 Menu structure

10.4.1 Configuration area „Unit 1“

Menus	Description
Detailed view “Parameter”	Basic settings of the device
Valve configuration	Adjustment or modification of the base settings. The settings in these menus may also be adjusted as described in section “10.3” using the start-up wizard.
Fault handling	
Diagnostics	
Position feedback sensor	
	<ul style="list-style-type: none"> • Type and method of operation of the pilot valves used • Action and state in the event of a fault • Settings for switching cycle counter for pilot valve/actuator • Specification of feedback source and fault detection
Detailed view “Diagnostics”	Channel diagnostics
Channel maintenance	Check each individual channel for maintenance requests or errors.
Channel fault	
Detailed view “Maintenance”	Maintenance settings
Actuator	<ul style="list-style-type: none"> • Reset the switching cycle counter for actuators and pilot valves • Set maintenance dates for the individual channels
Pilot valve	
Routine maintenance	

10.4.2 Configuration area „General settings“

Menus	Description/factory settings (if available)
Detailed view “Parameter”	
büS	
Displayed name	Device name, can be changed without affecting communication.
Location	Device installation location, displayed with the device name.
Description	Free description text, is used for example in tooltips.
Advanced	
Unique device name	Factory default number code . Used for partner assignments and should therefore not be changed!
Baud rate	50, 125, 250, 500 kbit/s or 1 Mbit/s
CANopen address	Entry of address/node ID. If the address is already used, the device will switch to a different address (only in büS mode).
Bus mode	CANopen, büS or standalone device
CANopen status	This menu is only displayed if “CANopen” is set as the bus mode.
Deallocation delay	0.5 s Time between loss of a partner and deletion of its configuration. Entry is possible, but usually does not need to be changed. This value only has an effect if in büS mode.
Alarm limits	
Supply voltage	
Error high	26.4 V
Error low	21.6 V
Hysteresis	1.0 V
Device temperature	
Error high	85°C
Error low	-20 °C
Hysteresis	2.0°C
Diagnostics	Switch complete diagnostics on or off
PDO Configuration	Enter the transmission times
PDO 1	10 ms inhibit time 2s event timer
Reset to default values	Reset PDO settings
Demo mode	Off Special mode for trade fairs and presentations
Display	Display
Brightness	70 %
Contrast	50 %
Setup	Entry of base settings via a start-up wizard

Menus	Description
Detailed view “Diagnostics”	Shows live values of device
Device status	
Operating duration	
Device temperature	
Supply voltage	
Voltage drops	Number of voltage drops since last reboot
Min./Max. values	Display of maximum and minimum values measured
Max. temperature	
Min. temperature	
Max. supply voltage	
Min. supply voltage	
Device boot counter	
Current system time	
büS status	
Receive errors	Current reception error count
Receive errors max.	Maximum values since device reboot
Transmit errors	Current transmission error count
Transmit errors max.	Maximum value since device reboot
Reset error counter	Resets both maximum values
CANopen status	Displays status
Logbook	Record and archive events
Detailed view “Maintenance”	
Device information	
Displayed name	Only displayed if a name was entered in the menu of the same name for the “Parameters” detailed view
Ident. number	
Serial number	
Software ident. number	
Software version	
büS version	
Hardware version	
Product type number	
Manufacture date	
eds version	
Device driver	
Driver version	
Firmware group	
DLL version	
Origin	
Reset device	
Restart	
Reset to factory settings	Resets all settings to factory defaults

11 CONFIGURATION VIA FIELDBUS

The AirLINE Field Type 8653 field module can be used in bÜS networks or CANopen networks.

The device can be used with other fieldbuses in combination with the Type ME43 Fieldbus Gateway or the Type 8652 AirLINE valve island.

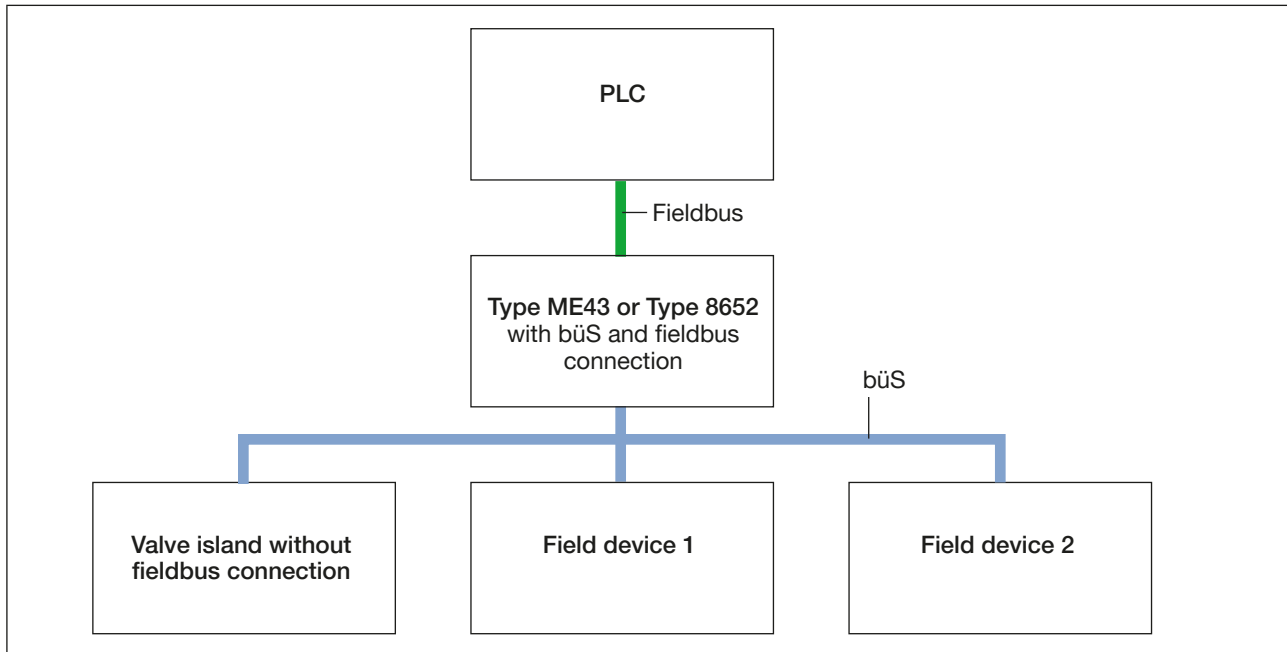

Fig. 15: Schematic layout of a bus system with various expansion devices

The process for configuring the network is described in the operating instructions of the device in question:



Operating instructions for fieldbus gateway ME43:

www.burkert.com → Type ME43, chapter “SETTING UP THE bÜS NETWORK”

Operating instructions for AirLINE Type 8652 valve island:

www.burkert.com → Type 8652, chapter “Using extension modules (EM)”

11.1 Cabling of bÜS/CANopen networks



Further information on cabling bÜS/CANopen networks can be found under the following link:

[Guide for planning of bÜS networks](#)

11.2 Start-up file

The start-up file (EDS file) and the description of the device-specific objects are available on the internet. Please refer to the documentation of your project design software for instructions regarding the installation of the start-up file.

Fieldbus	Start-up file
CANopen	EDS file
IO-Link	IODD file



Download the start-up file and the description of the device-specific objects at:
www.burkert.com → Type 8653 → DeviceDescription

The standard objects are described in a separate software manual:
www.burkert.com → Type 8653 „CANopen Network configuration“

11.3 Bit-by-bit compilation of the inputs and outputs

The field device consists of 1 valve unit with a maximum of 8 valves (= 4 double valves).

Each valve unit has

- 1 byte cyclic output for valve status
- 1 byte cyclic output for current position feedback status of the upper end position
- 1 byte cyclic output for current position feedback status of the lower end position
- 1 byte cyclic input for valves
- 1 byte cyclic input for external position feedback of the upper end position
- 1 byte cyclic input for external position feedback of the lower end position

11.3.1 Examples of bit-by-bit allocation of valve units

Valve unit with 4 double valves (example using BM1_Valves)

BM1_Valves							
Bit 0	Bit 1	Bit 2	Bit 3	Bit 4	Bit 5	Bit 6	Bit 7
Valve 1	Valve 2	Valve 3	Valve 4	Valve 5	Valve 6	Valve 7	Valve 8
Pneumatic connection							
2	4	2	4	2	4	2	4

Table 3: Example for the allocation of bits in the BM1 valves for double valves

If single valves are present in a valve unit, the next bit is skipped after a single valve (see example below).

Valve unit with 2 single valves and 2 double valves (example using BM1_Valves):

BM1_Valves					
2 single valves			2 double valves		
Bit 0	Bit 2	Bit 4	Bit 5	Bit 6	Bit 7
Valve 1	Valve 3	Valve 5	Valve 6	Valve 7	Valve 8
Pneumatic connection					
4	4	2	4	2	4

Table 4: Example for the allocation of bits in the BM1 valves for 2 single valves and 2 double valves

12 START-UP

WARNING

Risk of injury due to incorrect operation.

Improper operation may result in injuries as well as damage to the device and its environment.

- ▶ Before start-up, ensure that the operating personnel are familiar with and completely understand the contents of the operating instructions.
- ▶ Observe safety instructions and information on intended use.
- ▶ Only adequately trained technicians may start up the device.

12.1 Starting up via manual override

The manual override is ideal for starting up the device and system. The manual override operates without the device being connected to the power supply and enables manual switching of the valves.

The manual overrides are marked differently depending on the circuit function (CF) of the valves:

CFC, CFZ, CFH (with CFH only 1 manual override):

Marking	Impact of the switched manual override
12	Supply duct 1 connected to working port 2
14	Supply duct 1 connected to working port 4

CFD:

Marking	Impact of the switched manual override
10 (12)	Connection from supply duct 1 to working port 2 interrupted
10 (14)	Connection from supply duct 1 to working port 4 interrupted

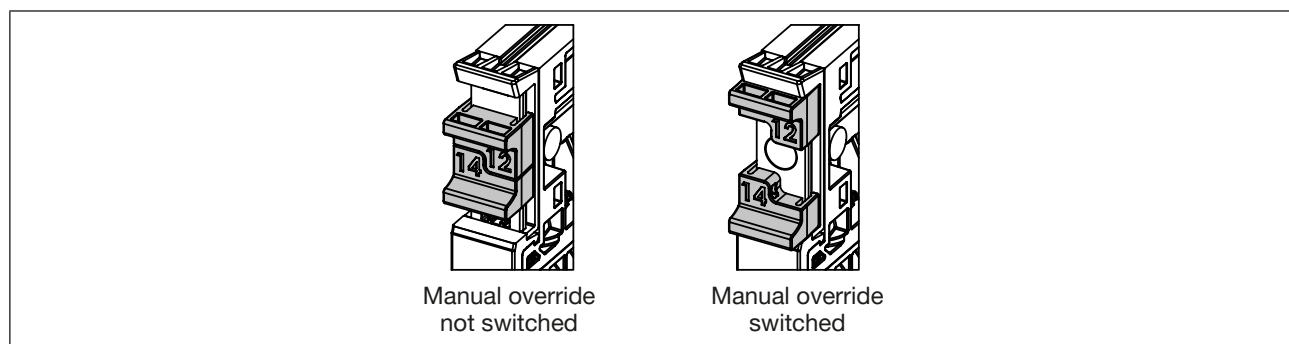

Fig. 16: Manual override of valves

The manual override provides both spring-return and latching action as standard.

Spring return:

If the slide mechanism is moved to an initial resistance, the manual override returns to the unswitched state once it is released.

Latching:

If the resistance is exceeded, the manual override remains in the switched state after being released. Manually push the slide mechanism back over the locking point to reset the manual override to the unswitched state.

12.1.1 Additional element “MO locking”

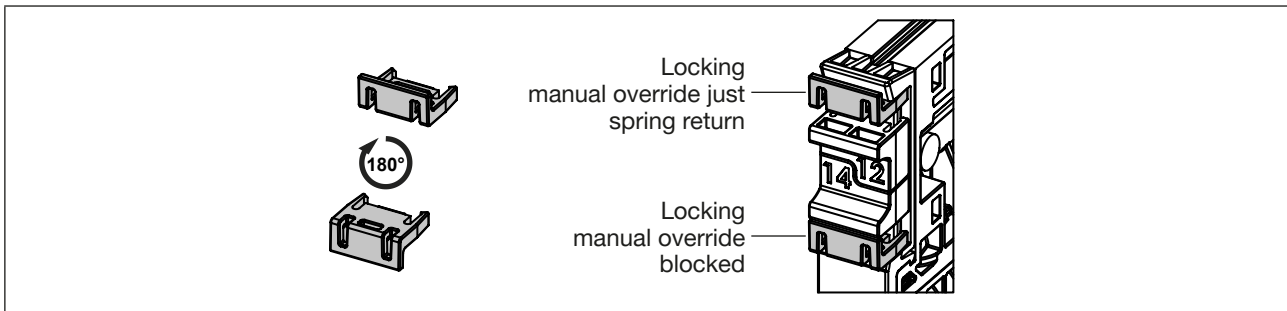

Fig. 17: Additional element “MO locking”

The additional element “MO locking” helps to restrict the manual override.

Depending on the position (rotated 0° or 180°) of the clipped-on additional element, the manual override is just spring return or blocked.

12.2 Marking the valve slots

The device is supplied with MultiCard format device markers:

Device marker ESG 5/10 MC NE WS

The individual device markers are fixed to a sprue and can be printed in this form using standardised industrial printers (e.g. from Weidmüller). After printing, remove the device markers from the sprue and clip them onto the field module.

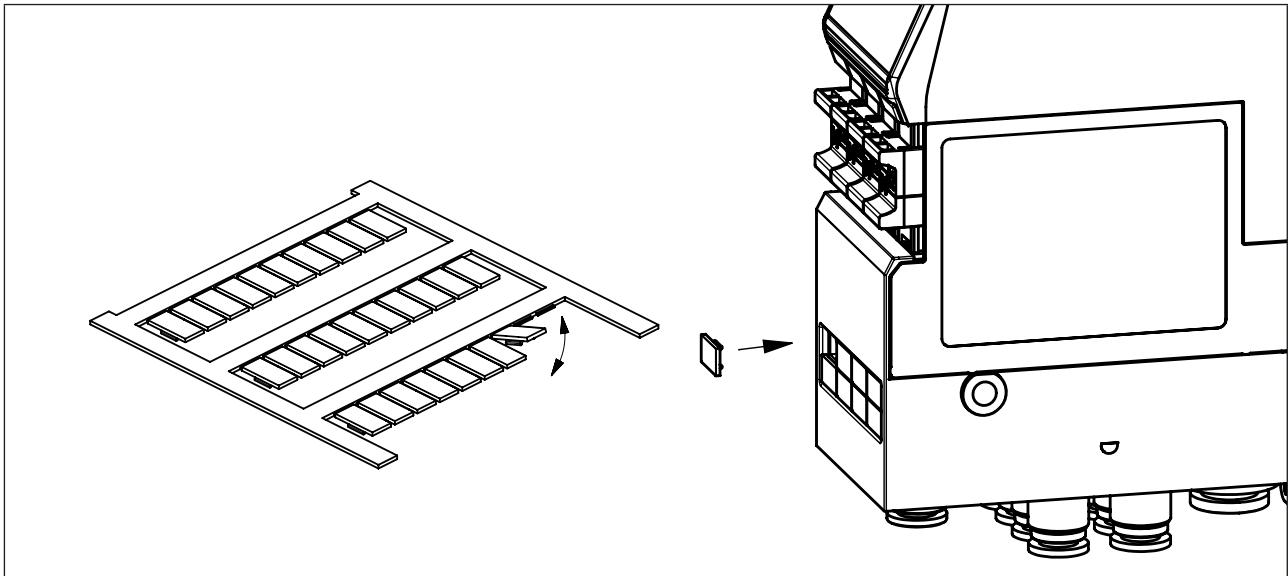

Fig. 18: Marking the valve slots using MultiCard format device markers

13 OPERATION

13.1 Display elements



Fig. 19: Display elements for AirLINE Field Type 8653 field module

13.2 Display







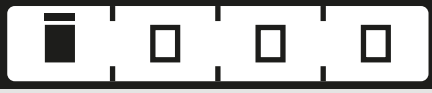

The device is equipped with an LCD for displaying the status. The switching position and potential error states of the output are displayed graphically on the display. Further information can be displayed depending on the configuration of the device, e.g.

– position of the actuator allocated to the output.

Messages (information, warnings, error) appear as text on the LC display. The text message display alternates cyclically with the graphical display of the channel status.

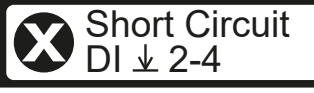
13.2.1 Display views

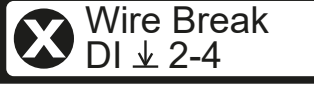
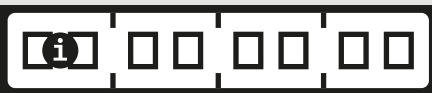
	Display view with 4 valve slots (e.g. 5/2-way valves)
	Display view with 4 valve slots (double valves, e.g. 2x3/2-way valves)
	Mixed display view (double and single valves)
	Valve 1 actuated

	<p>Valve 1 actuated, feedback: "Upper end position reached"</p>	
	<p>Valve 1 actuated, feedback: "Lower end position reached"</p>	
<p>Alternating message 1 / message 2:</p> <p>Message 1</p>  <p>Message 2</p> 	<p>Short circuit at input 2 of the upper position feedback unit</p>	<p>Example of other possible messages:</p>  <p>Short circuit at inputs 2-4 of the lower position feedback unit</p>
<p>Alternating message 1 / message 2:</p> <p>Message 1</p>  <p>Message 2</p> 	<p>Wire break at input 2 of the upper position feedback unit</p>	<p>Example of other possible messages:</p>  <p>Wire break at inputs 2-4 of the lower position feedback unit</p>
<p>Alternating message 1 / message 2:</p> <p>Message 1</p>  <p>Message 2</p> 	<p>Maintenance limit for pilot valve 1 reached</p>	<p>Example of other possible messages:</p>  <p>Maintenance limit for actuator 1 reached</p>

13.3 LED status display

The LED for displaying the device status changes colour and status similar to NAMUR NE 107.

If several device statuses exist simultaneously, the device status with the highest priority is displayed. The priority depends on the severity of the deviation from standard operation (red = failure = highest priority).

Status display in accordance with NE 107, edition 2006-06-12			
Colour	Colour code	Description	Meaning
red	5	Failure, error or malfunction	Standard operation is not possible due to malfunctioning in the device or peripheral devices.
orange	4	Function check	An internal function/check is performed. This status is exited automatically after a certain time. No user intervention required.
yellow	3	Out of specification	Deviation of parameters (e.g. different address/node ID used). → Check parameters.
blue	2	Maintenance required	The device is in standard operation mode, however, a function could soon be restricted. → Perform device maintenance.
green	1	Diagnostics active	Device is operating perfectly. Status changes are indicated in different colours. Messages are transmitted by a fieldbus if connected.
white	0	Diagnostics inactive	Device is switched on. Status conditions are not displayed. Messages are not displayed in the message list or transmitted via a potentially connected fieldbus. Device operates within its specifications.

Table 5: Device status indication based on NAMUR NE 107

14 MAINTENANCE, TROUBLESHOOTING



WARNING

Risk of injury due to incorrect maintenance work.

- ▶ Maintenance may be carried out by authorised technicians only and with the appropriate tools!

Risk of injury due to unintentional switching on of the plant and uncontrolled start-up.

- ▶ Secure system against unintentional activation.
- ▶ Ensure controlled start-up after maintenance.

14.1 Troubleshooting

Fault	Possible cause	Remedy
Valves do not switch	No or insufficient load voltage	Check electrical connection Ensure correct load voltage
	Manual override of the valves not in the neutral position	Move the manual override to the neutral position
	Pressure supply insufficient or not available	Ensure a sufficient pressure supply (also for upstream devices such as pressure controllers, maintenance units, shut-off valves, etc.)
		The pressure port for auxiliary pilot air (X / 12/14) must always be connected. Guarantee minimum operating pressure of 3.0 bar and observe the ratio of pilot pressure to medium pressure in accordance with the pilot pressure diagram (see chapter "6.4.2" on page 15)
	Incorrect design	Design the system according to the hardware design
Channel not released for operation	Change the parameter setting (Bürkert Communicator)	

Fault	Possible cause	Remedy
Valves switching delayed or blow off at the exhaust ports	Pressure supply insufficient or not available	Ensure a sufficient pressure supply (also for upstream devices such as pressure controllers, maintenance units, shut-off valves, etc.)
		The pressure port for auxiliary pilot air (X / 12/14) must always be connected. Guarantee minimum operating pressure of 3.0 bar and observe the ratio of pilot pressure to medium pressure in accordance with the pilot pressure diagram (see chapter "6.4.2" on page 15)
	Insufficient pilot pressure build-up	With 5/2-way valves (control function H) and 2x3/2-way valves (control function D, normally open), operate the valve island with an external pilot pressure supply
	Valves are not in the home position when building up pressure (de-energised)	Pressurise the valve block before switching the valves
	Insufficient venting of the exhaust air channels due to insufficiently dimensioned or soiled sound absorbers (back pressures)	
		Clean soiled sound absorbers

14.2 Fault messages LCD

An overview of the possible display contents can be found in chapter “13.2.1 Display views” on page 36.

Message	Possible cause	Remedy
No message, LC display off	No or insufficient load voltage	Check electrical connection Ensure correct load voltage
	Voltage interrupted during firmware update	Update firmware again
Pilot SCC Limit Ch. x or Act. SCC Limit Ch. x	Maintenance limit for pilot valve / actuator channel X reached	Replace the pilot valve or maintain the actuator and reset the switching cycle counter or deactivate the switching cycle counter or increase the warning limit of the switching cycle counter
Short Circuit Ch. x	Short circuit at input x of the position feedback unit (position feedback or push-in connection faulty)	Check the position feedback/push-in connection or replace the position feedback
Wire Break Ch. x	Wire break at input x of the position feedback unit (position feedback or push-in connection faulty)	Check the position feedback/push-in connection or replace the position feedback

15 REMOVAL



DANGER

Risk of injury from high pressure and discharge of medium.

- ▶ Before working on the device or system, secure the actuators against moving.
- ▶ Before working on the device or system, switch off the pressure. Vent or drain lines.



WARNING

Risk of injury from electric shock.

- ▶ Before working on the device or system, switch off the power supply. Secure against reactivation.
- ▶ Observe applicable accident prevention and safety regulations for electrical equipment.

Risk of injury due to improper removal!

- ▶ Removal should be performed only by trained personnel using suitable tools.

→ Undo the pneumatic connection.

→ Undo the electrical connection.

For assembly using the bracket

→ Push back the lever for unlocking the device and at the same time pull the device upwards out of the bracket.

For assembly on standard rail

→ Push back the lever for unlocking the device and at the same time pull the device upwards out of the bracket.

→ Using a slotted-head screwdriver, carefully turn the fastening screws on the bracket all the way anticlockwise.

→ Tilt the bracket upward slightly and remove it from the standard rail.

16 ACCESSORIES

CAUTION

Risk of injury, property damage due to incorrect parts!

Incorrect accessories and unsuitable spare parts may cause injuries and damage the device and its environment.

► Use original accessories and original spare parts from Bürkert only.

büS accessories

Article	Quantity	Order no.
USB-büS-Interface set 1 (including power supply unit, büS stick, terminating resistor, Y-distributor, 0.7 m cable with M12 plug)		772426
USB-büS-Interface set 2 (including büS stick, terminating resistor, Y-distributor, 0.7 m cable with M12 plug)		772551
büS cable, angled M12 (stranded wire to female connector)	0.7 m	772626
büS cable (stranded wire to M12 female connector)	1.0 m	772409
	3.0 m	772410
	5.0 m	772411
	10.0 m	772412
büS cable drum	50.0 m	772413
	100.0 m	772414
büS extension cable	0.1 m	772492
	0.2 m	772402
	0.5 m	772403
	1.0 m	772404
	3.0 m	772405
	5.0 m	772406
	10.0 m	772407
	20.0 m	772408
büS service cable M12 to micro USB		773254

Electrical accessories

Article	Quantity [unit]	Order no.
Termination resistor, M12 male	1	772424
Termination resistor, M12 female	1	772425
Gender changer, M12, male-male	1	772867
Y-distributor	1	772420
Y-distributor with interrupt	1	772421

Attachment accessories

Article	Quantity [unit]	Order no.
Screw set M5x10 A2 DIN 6912 (for attaching the valve island to the base of the control cabinet)	10	308661
Holding plate (for control cabinet exterior)	4x	60005571
	8x	60005566
	12x	60005567
	16x	60005568
	20x	60005569
	24x	60005570

Pneumatic accessories

Article	Quantity	Order no.	
Filter set for auxiliary pilot air	2	368590	
Push-in connector, straight	Brass, nickel-plated	M7 Ø 6 mm	773459
		M7 Ø 1/4"	773460
		G1/4" Ø 10mm	773461
		G1/4" Ø 3/8"	773462
	Stainless steel	M7 Ø 6 mm	773463
		M7 Ø 1/4"	773464
		G1/4" Ø 10 mm	773465
		G1/4" Ø 3/8"	773466
Plastic hoses for pneumatic system, polyamide (PA)	Ø 6/4 mm	Blue	780643
		Black	780644
		Natural	780645
	Ø 8/6 mm	Blue	780646
		Black	780647
		Natural	780648
	Ø 10/8 mm	Blue	780649
		Black	780650
		Natural	780651
	Ø 6/4 mm	Blue	771868
		Black	771295
		Natural	771296
	Ø 8/6 mm	Blue	771869
		Black	771873
		Natural	771297
	Ø 10/8 mm	Blue	771870
		Black	771877
		Natural	771874

MAN 1000381061 ML Version: G Status: RL (released | freigegeben) printed: 30.04.2025

Article			Quantity	Order no.
Push-in silencer	Ø 6 mm	Sintered bronze, brass nickel- plated body	1	784306
	Ø 8 mm			784304
	Ø 10 mm			784305
	Ø 6 mm	Polyethylene (PE)		772571
	Ø 8 mm			773231
	Ø 10 mm			773522
	1/4"			773545
	3/8"			773546
Sealing plug	Brass, nickel-plated	08/06-08/06	1	781666
		10/08-10/08		781667
	POM	06/04-06/04		782399
		08/06-08/06		782400
		10/08-10/08, red		782401
	PBTP	6 mm		771605
		8 mm		771606
		10 mm		771607

Other accessories

Article	Quantity [unit]	Order no.
Device marker set	10 (1 screen)	368588
Interlocking set MO (manual override)	8	328082
Micro SD card		on request

17 PACKAGING, TRANSPORT

NOTE

Damage in transit due to inadequately protected devices.

- ▶ Protect the device against moisture and dirt in shock-resistant packaging during transportation.
- ▶ Observe permitted storage temperature.

18 STORAGE

NOTE

Incorrect storage may damage the device.

- ▶ Store the device in a dry and dust-free location.
- ▶ Storage temperature $-10\dots+60$ °C.

19 DISPOSAL

NOTE

Damage to the environment caused by device components contaminated with media.

- ▶ Dispose of the device and packaging in an environmentally friendly manner.
- ▶ Observe applicable disposal and environmental regulations.



- ▶ Observe national regulations on the disposal of waste.