

Operating Instructions

Bedienungsanleitung
Instructions de service

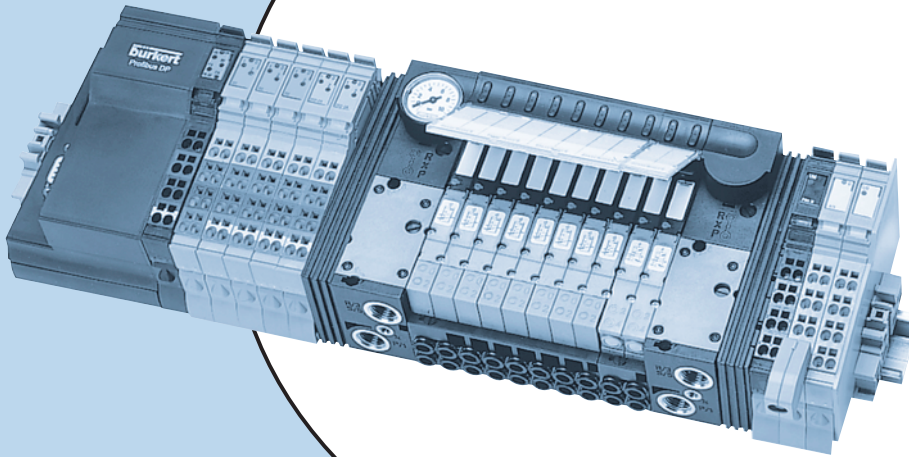

Type 8644 AirLINE

with Inline (Phoenix Contact)

mit Inline (Phoenix Contact)

avec Inline (Phoenix Contact)

We reserve the right to make technical changes without notice.
Technische Änderungen vorbehalten.
Sous réserve de modification techniques.

© Bürkert Werke GmbH & Co. KG, 2002/2025

Operating Instructions 2504/14_EU-EN_00804636

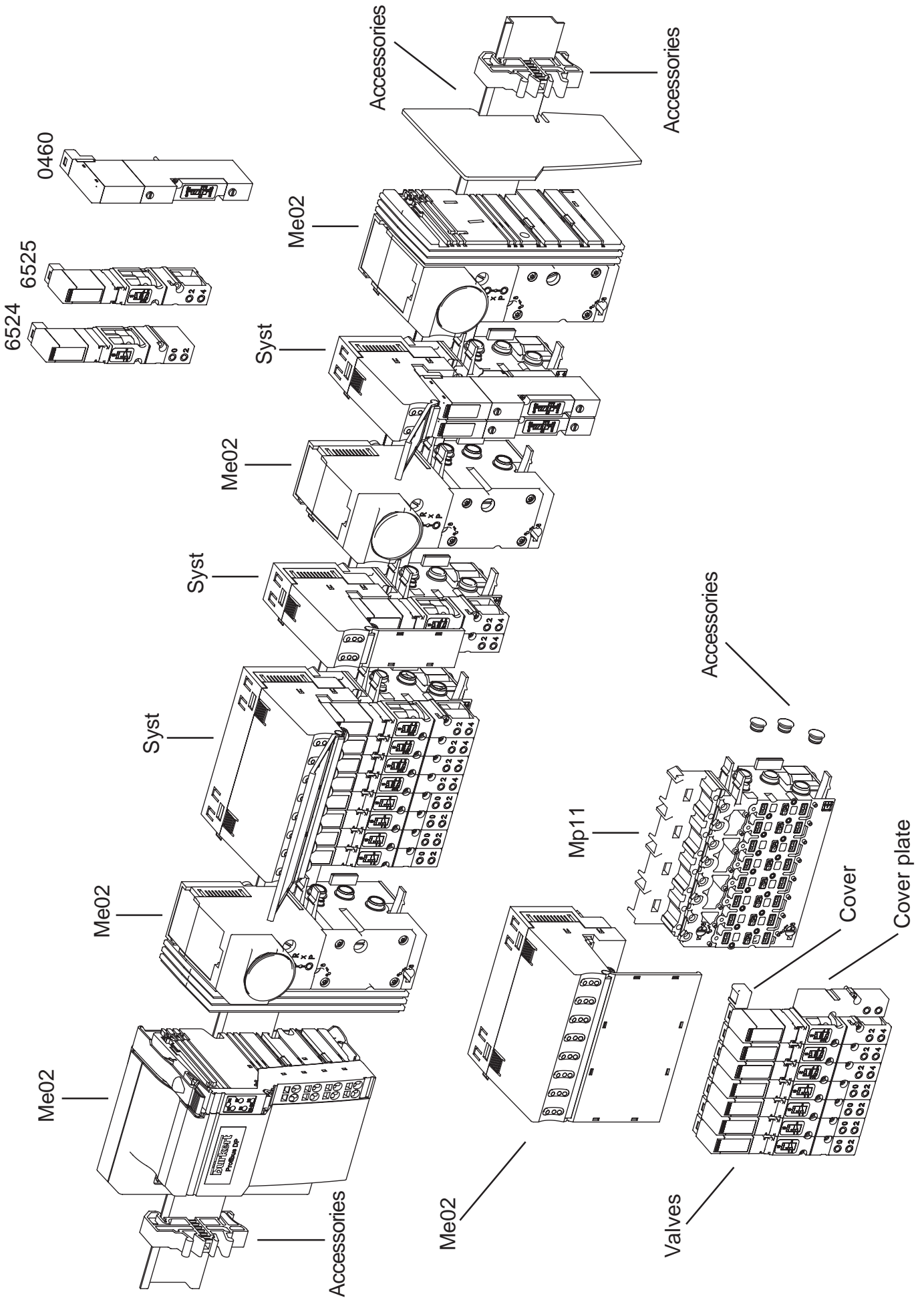

Add-on dimension 11 mm

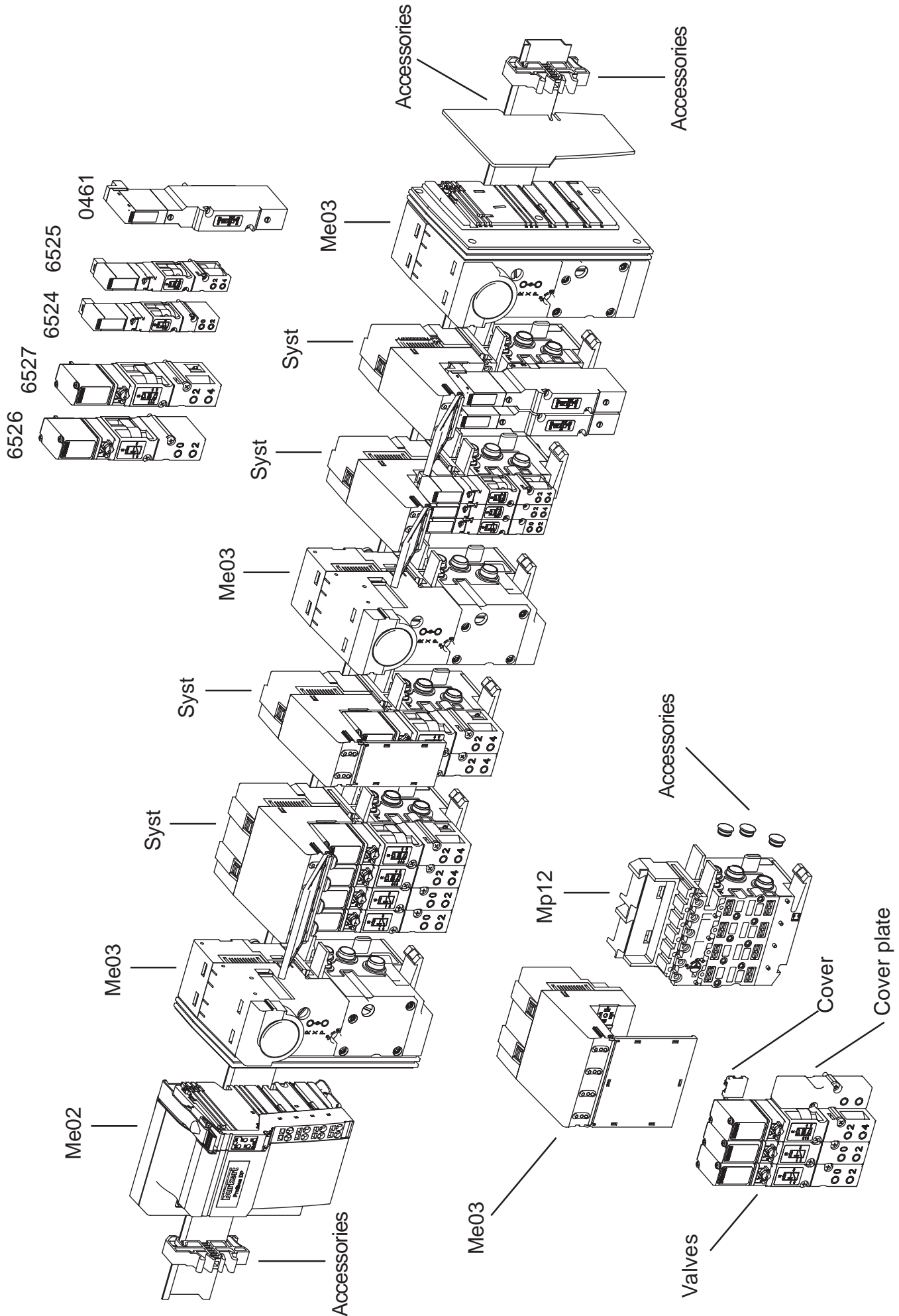

Add-on dimension 16,5 mm

List of contents

Type 8644 AirLINE -Phoenix

GENERAL NOTES	3
Symbols	4
Intended use	4
General safety notes	4
Scope of delivery	6
Warranty conditions	6
Approvals	6
Assembly note	6
Information of the Internet	6
 INSTALLATION/COMMISSIONING	 7
Installation instructions	8
Illustration of the Valve block	8
Removing the valve block from the top-hat rail	9
Installation of the AirLINE system	10
Fluidic installation	11
Labelling of the connections	12
Elektrical installation	13
Fluidic commissioning	13
Electrical commissioning	13
 MAINTENANCE AND TROUBLESHOOTING	 15
Troubleshooting	16

MAN 1000010120 EN Version: K Status: RL (released | freigegeben) printed: 23.04.2025

SYSTEM DESCRIPTION	18
Bürkert-AirLINE modulare electrical / pneumatic automation system	19
Valve block	22
Field bus node Profibus DP	26
Field bus node Profibus DPV1	42
Connector modules	90
Electronic pressure measurement module (PMM)	104
Basic electronic modules	111
Basic pneumatic module	119
Valves	121
ANNEX	A1
EC Declaration of Conformity	A2
Certificate of Conformity	A3

General Notes

SYMBOLS	4
INTENDED USE	4
GENERAL SAFETY NOTES	4
Protection from damage by electrostatic charging	5
Safety notes for the valve	5
SCOPE OF DELIVERY	6
WARRANTY CONDITIONS	6
APPROVALS	6
ASSEMBLY NOTE	6
INFORMATION ON THE INTERNET	6

SYMBOLS

The following symbols are used in these operating instructions:

→ marks a work step that you must carry out



ATTENTION!

marks notes on whose non-observance your health or the functioning of the device will be endangered.



NOTE

marks important additional information, tips and recommendations

INTENDED USE

The device is used exclusively as an electrical/pneumatic automation system in conjunction with Phoenix electronics modules. It is designed for use in the switching cabinet or control box. The device must only be operated using the values indicated in the "Technical data for the overall system" and "Technical data for the valve block" sections and on the type plates.

Read the instructions for use carefully. In particular, follow the chapter "General safety information". The operating manual describes the entire life cycle of the device. Retain the operating instructions so that they are accessible for the respective user.

The safety features of the device may not be circumvented under any circumstances. It is imperative to comply with all accident prevention stipulations. The components mounted on commissioning must not be disassembled without express, written working instructions.

The system must only be installed and maintained by trained specialist personnel.

Unauthorized rebuilding or changes within the system are not allowed for safety reasons. When exchanging parts due to failure or normal wear, use only original replacement parts.

Attention must be paid to the working instructions in the individual sections. The safety information must be complied with at all times. Should working instructions, their sequence, safety information or the safety label not be complied with, the claim for liability shall lapse.

GENERAL SAFETY NOTES

- Keep to standard engineering rules in planning the use of and operating the device!
- Installation and maintenance work are only allowed by specialist personnel using suitable tools!
- Observe the current regulations on accident prevention and safety for electrical devices during operation, maintenance and repair of the device!
- Always switch off the power supply before intervening in the system!
- Note that in systems under pressure, piping and valves may not be loosened!
- Take suitable precautions to prevent inadvertent operation or damage by unauthorized action!
- After interruption of the electrical or pneumatic supply, make sure the process is restarted in a well-defined, controlled manner!
- On non-observance of these notes and unauthorized interference with the device, we will refuse all liability and the warranty on device and accessories will become void!

Protection from damage by electrostatic charging



ATTENTION
EXERCISE CAUTION ON
HANDLING!
ELECTROSTATICALLY
SENSITIVE COMPONENTS/
MODULES!

The unit contains electronic components that are very sensitive to electrostatic discharge (EDS). Contact to electrostatically charged persons or objects will endanger these components. In the worst case, they will be immediately destroyed or will fail after commissioning.

Observe the requirements of EN 100 015 - 1 in order to minimize the possibility of, or avoid, damage from instantaneous electrostatic discharge. Also take care not to touch components that are under supply voltage.

Safety notes for the valve

- Keep to standard engineering rules in planning the use of and operating the device!
- Take suitable precautions to prevent inadvertent operation or damage by unauthorized action!
- Note that in systems under pressure, piping and valves may not be loosened!

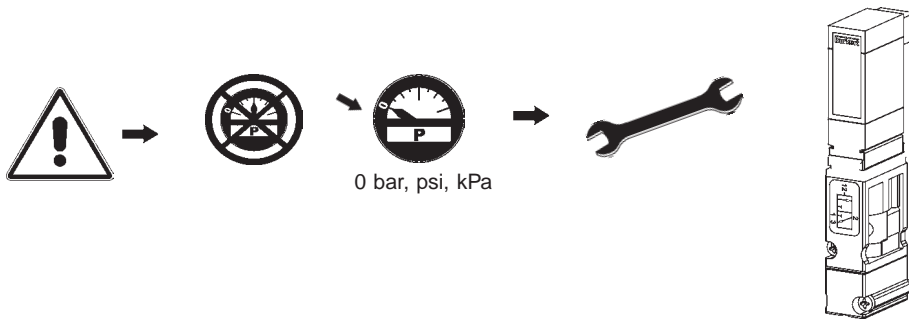

- Always switch off the power supply before intervening in the system !

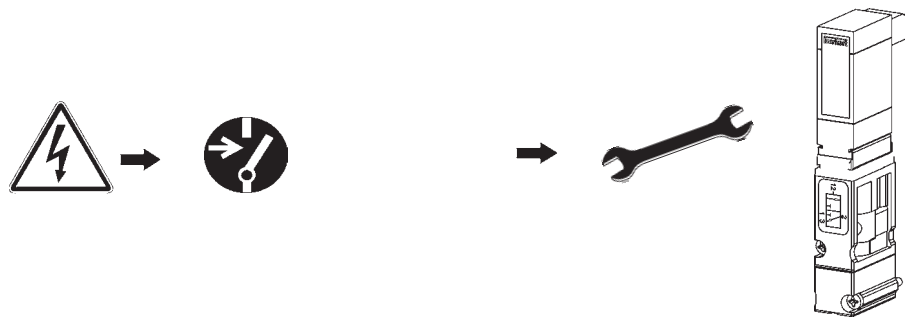

- To avoid pressure drop on switching, make the volume of the pressure supply as large as possible!



- The device shall only be operated on direct current!



- Risk of injury!
In continuous operation, the coil can become very hot!

SCOPE OF DELIVERY

Immediately after receipt of the goods, make sure the contents are undamaged and agree with the scope of delivery stated on the packing slip.

In case of any discrepancies, please contact our Call Center

Bürkert Fluid Control Systems
Call-Center
Chr.-Bürkert-Str. 13-17
D-76453 Ingelfingen
Tel.: (07940) 10-111
Fax: (07940) 10-448
E-mail: info@de.buerkert.com

or your local Bürkert Sales Center immediately.

WARRANTY CONDITIONS

This document contains no warranty statements. In this connection we refer to our general sales and business conditions. A prerequisite for validity of the warranty is use of the device as intended with observance of the specified conditions of use.



ATTENTION!

The warranty covers only faultless condition of the automation system and the attached valves supplied. No liability will be accepted for consequential damage of any kind that may arise from failure or malfunctioning of the device.

APPROVALS

The approval marks on Bürkert rating plates refer to the Bürkert products. In order that the complete valve island is approved, a gateway with a design inspection certificate must be used. In this case, a valve island may be extended with approved units having design inspection certificates up to 64 valves.

More detailed information on the approvals of the valves is to be found in the chapter Valves.

ASSEMBLY NOTE

If the configuration of the valve block also provides of Type 0461 (5/2- way pulsed valve, 5/3- way valve), a profile rail EN 50022-35x15 must be used.

INFORMATION ON THE INTERNET

Operating instructions and data sheets for type 8644 may be found on the Internet under:

www.buerkert.com → Germany → Produkte → Downloads → Betriebsanleitungen → Typ 8644 Phoenix

Furthermore, a complete documentation is available on CD. The complete Operating instructions may be ordered under the following identification number: 804 636



HINWEIS

Technical data, configuration files and a detailed description of bus terminals and electrical function terminals by the Phoenix Contact company are available on the Internet web site:

www.phoenixcontact.com → Download & Documetation → Interbus & Automation → Documentation

Then enter in the search window e.g. "IL" as joker or the exact product designation.

Bürkert has no influence upon the update status of the latter home page or on changes in technical data or presentation on the pages linked thereto.

Installation / Commissioning

Installation instructions	8
Illustration of the Valve block	8
Removing the valve block from the top-hat rail	9
Installation of the AirLINE system	10
Fluidic installation	11
Labelling of the connections	12
Electrical installation	13
Fluidic commissioning	13
Electrical commissioning	13

Installation instructions

The AirLINE system Type 8644 may be combined with the electrical automation systems of various manufacturers. You should follow the respective installation instructions.



ATTENTION!

Before starting installation work, switch off the voltage in the vicinity and secure it against being switched on again.

Illustration of the Valve block

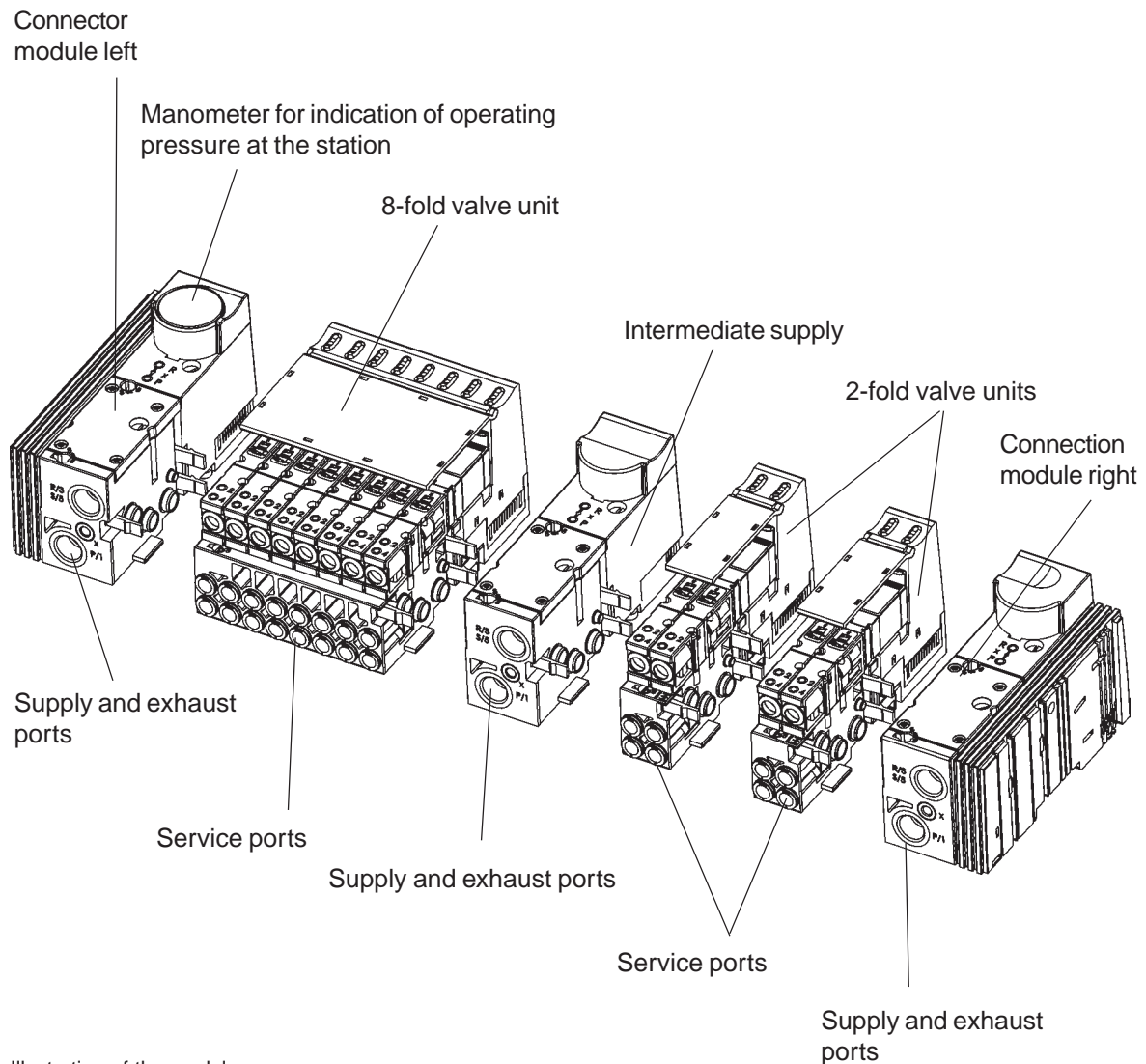

Illustration of the modules of the Bürkert AirLINE system

MAN 1000010120 EN Version: K Status: RL (released | freigegeben) printed: 23.04.2025

Removing the valve block from the top-hat rail

The valve block is firmly screwed to a standard rail. Additional electrical modules / terminals can be mounted on this.

→ If present, release the adjacent modules / terminals!

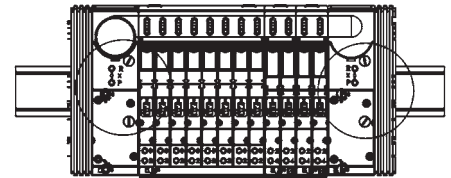

→ Unlock the Valve block from the standard rail by turning the fixing screws anticlockwise as far as they will go.

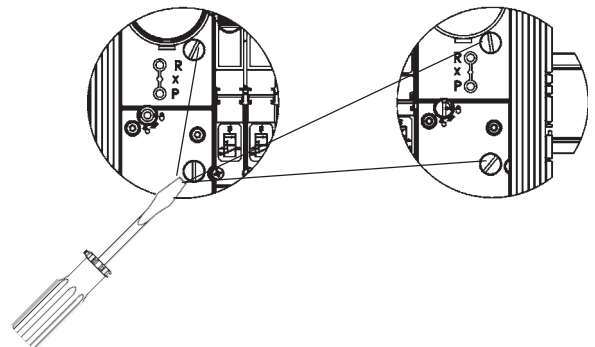

→ Lift the Valve block vertically from the rail.



NOTE

There must be sufficient clearance > 6 mm between Valve block and previous module.

→ Disconnect the modules / terminals from the standard rail following the manufacturer's instructions.

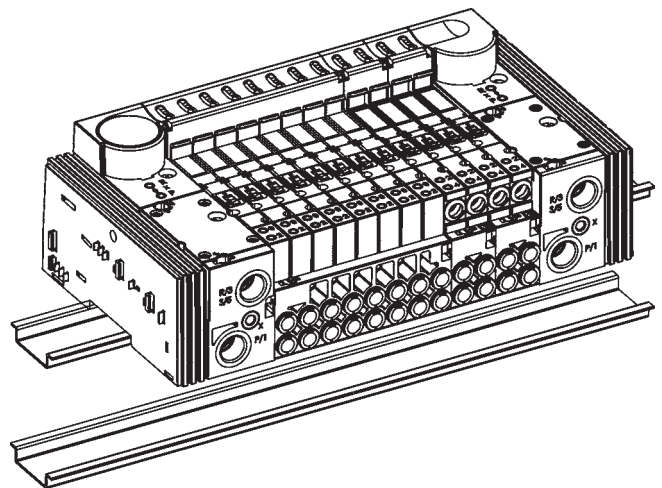

NOTE

The interface of the left-hand connection module contains elements that can be damaged if force is used. Never place the valve block on its side, and ensure that you use an approved installation position!

Installation of the AirLINE system (e.g. in a control cabinet)



ATTENTION!

During work in the control cabinet, observe the relevant safety regulations!

Before mounting, check whether the mounting rail is properly anchored in the control cabinet or in the system.

Observe the sequence of installation specified in the configuration file(s).

Observe the notes for the connected system!

→ Observing manufacturer's instructions, snap all electrical modules / terminals to the left of the valve block onto the standard rail.

→ Slide the valve block onto the rail along the interface of the preceding module.



NOTE

- Alternative for large valve blocks:
- Remove the preceding module
 - Snap the valve block onto the standard rail
 - Slide the block to its final position
 - Snap on the preceding module again

→ Screw the valve block to the rail by tightening the fixing screws clockwise.

→ Mount all other modules / terminals on the rail.



ATTENTION!

The valve block is not securely fastened to the standard rail until the fixing screws have been firmly tightened. Throughout the installation, you must ensure that it cannot fall.

Fluidic installation

Safety notes



ATTENTION!

The pneumatic connections shall not be pressurized during installation!

Make the connections with as large a volume as possible.

Close off unused, open ports with screw caps!

The ports for the pilot valve exhaust (x) shall not be closed off!

Check allocation according to instructions of ports 1 and 3 or 5: these shall under no circumstances be swapped!

Pneumatic connections - supply units

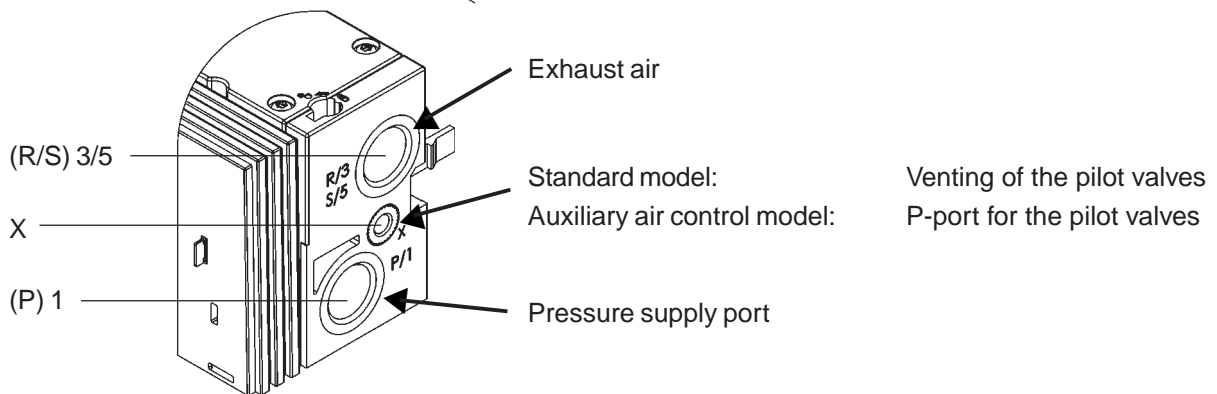

Procedure

→ Plug (D10) or screw (G 1/4, NPT 1/4) the connections, depending on the version, into the respective service ports.

Notes on plug connections



NOTE

- For the plug connections the hoses must fulfil the following requirements:
- Minimum hardness of 40 Shore D (to DIN 53505 or ISO 868);
 - Outside diameter to DIN 73378 (max. permissible deviation ± 0.1 mm from nominal dimension);
 - Free from burrs, cut off at right angles and undamaged over outer circumference;
 - The hoses shall be pushed into the plug connectors as far as they will go.

Disassembly of the plug connections

→ To release the hoses, depress the pressure ring and pull out the hose.

Tightening torques for port connections

Observe the following tightening torques when screwing into the port connections. The specified tightening torque may vary depending on the sealing system.

Port size	Marking/function	Recommended tightening torque [Nm]	Maximum tightening torque [Nm]
G3/8	P, R/S connection (connection modules 16 mm)	6...9	40
G1/4	P, R/S connection (connection modules 11 mm)	4...7	20
G1/8	Auxiliary pilot air (connection modules 16 mm)	3...6	10
M5	Auxiliary pilot air (connection modules 11 mm)	1...1.2	3

Pneumatic connections - valve units



NOTE || With 3/2-way valves, the upper ports remain free!

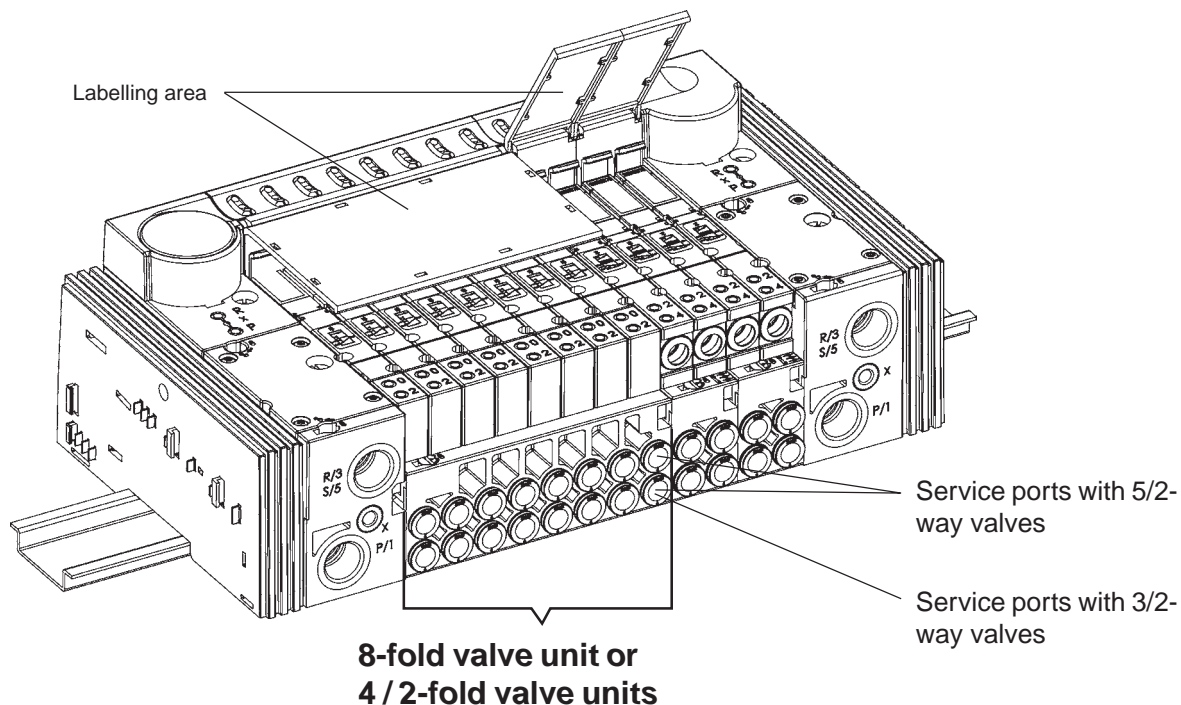

Variants

5/2-way valves

	Variant 1	Variant 2	Variant 3
Service port above (2)	M 5	M 7	D 6, D4, D1/4
Service part below (4)	M 5	M 7	D 6, D4, D1/4

3/2-way valves

	Variant 1	Variant 2	Variant 3
Service port above (0)	internally closed off	internally closed off	internally closed off
Service port below (2)	M 5	M 7	D 6, D4, D1/4

Assembly

- Plug (D6, D4, D1/4) or screw (M 5, M7) the connections, depending on the version, into the respective service ports.
- With threaded versions, connecting nipples may be used.

Labelling of the connections

- Write the valve port data on the provided Labels.

Elektrical installation

You can find information regarding the electrical installation:

- in the Phoenix Contact handbook *Interbus - Inline IB IL SYS PRO UM*
- or in the *System Description* chapter, Paragraph *Field Bus Nodes Profibus DP*

Fluidic commissioning

Measures to be taken before fluidic initialization

- Check the connections, voltage and operating pressure!
- Make sure that the max. operating data (see rating plate) are not exceeded!
- Check allocation according to instructions of ports 1 and 3 or 5: these shall under no circumstances be swapped!
- For electrical operation, unlock the manual override!

Fluidic commissioning

- Switch on the pressure supply.



- Only then switch on the voltage!

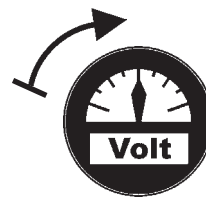

Electrical commissioning

You can find information regarding the electrical initialization:

- in the Phoenix Contact handbook *Interbus - Inline IB IL SYS PRO UM*
- or in the *System Description* chapter, Paragraph *Field Bus Nodes Profibus DP*

MAN 1000010120 EN Version: K Status: RL (released | freigegeben) printed: 23.04.2025

Maintenance and troubleshooting

TROUBLESHOOTING 16

TROUBLESHOOTING

Fault	Possible cause	Remedy
Valves do not switch:	Operating voltage not present or insufficient;	→ Check the electrical connection. → Provide operating voltage acc. to nameplate.
	Manual override knob not in neutral position;	→ Turn knob to zero position.
	Pressure supply insufficient or not present.	→ Execute pressure supply with as large a volume as possible (also for upstream devices such as pressure controllers, maintenance units, shut-off valves, etc.). Minimum operating pressure ≥ 2,5 bar
Valves switch with delay or blow out at the vent connections:	Pressure supply insufficient or not present;	→ Execute pressure supply with as large a volume as possible (also for upstream devices such as pressure controllers, maintenance units, shut-off valves, etc.). Minimum operating pressure ≥ 2,5 bar
	Valves not in basic position (no power) during pressure build-up;	→ Pressurize the valve block before the valve switch!
	Venting of exhaust aire channels insufficient because silencers are too small or contaminated (backpressure);	→ Use matching, large-sized silencers or expansion vessels. → Clean the contaminated silencers.
	Contamination or foreign bodies in pilot or main valve.	→ Change the valve
Leaky valve blocks:	O-rings missing or pinched between the modules;	→ Determine the point of leakage or missing seals.
	missing or wrongly positioned profile seals between the valve and the basic pneumatic module.	→ Insert missing seals or replace damaged seals.

MAN 1000010120 EN Version: K Status: RL (released | freigegeben) printed: 23.04.2025



NOTES

|| The further error descriptions, see User's Manual *Interbus - Inline IB IL SYS PRO UM* or the chapter *System Descriptions*, section *Field Bus Nodes Profibus DP*.

Service address:

Fluid Control Systems
 Service-Department
 Chr.-Bürkert-Str. 13-17
 D-76453 Ingelfingen
 Tel.: (07940) 10-111
 Fax: (07940) 10-448
 E-mail: info@de.buerkert.com

or your Bürkert distribution center (see list of addresses on the last few pages)

System description

BÜRKERT AIRLINE MODULAR ELECTRICAL / PNEUMATIC AUTOMATION SYSTEM..... 19

Features 19

Advantage 19

Design of the system 20

VALVE BLOCK..... 22

Connector modules / feeders 22

Valve units 23

Technical data for the valve block 24

Technical data for the complete system 25

FIELD BUS NODE PROFIBUS DP 26

Description of the Profibus DP field bus node 26

Technical data of the field bus module Profibus DP bus node 31

Installation and electrical commissioning of the field bus node Profibus DP 33

Electrical installation of the field bus node Profibus DP 35

Configuration of the Profibus DP bus node 37

Diagnosis and error elimination at the Profibus DB bus node 40

FIELD BUS NODE PROFIBUS DPV1 42

New functions 42

Overview of firmware functionalities 43

Description of field bus node 44

PCP via process data (PCP in DPV0) 54

Parameterization 62

Failsafe values 65

Watchdog 68

Acknowledgement of peripheral errors 70

Behaviour in PLC stop (new) 71

MAN 1000010120 EN Version: K Status: RL (released | freigegeben) printed: 23.04.2025

Diagnosis (new)	72
Parameter telegram format	76
Switching round bytes for IB IL24 DI16 / IB IL24 DO16	78
Switching round bytes for IB IL24 DI32 / IB IL24 DO32	78
Data Exchange and Global Command Operate	79
DPV1 field bus node object directory	80
Error codes during DPV1 communication	82
Error codes during PCP communication	83
Error description	85
CONNECTOR MODULES	90
Connector Module, pneumatic - left Type ME02	92
Connector Module, pneumatic - left Type ME03	94
Connector Module, pneumatic - middle Type ME02	96
Connector Module, pneumatic - middle Type ME03	98
Connector Module, pneumatic - right Type ME02	100
Connector Module, pneumatic - right Type ME03	102
ELECTRONIC PRESSURE MEASUREMENT MODULE (DMM)	104
BASIC ELECTRONIC MODULES	111
Basic electronic module ME02 / 2-fold monostable	112
Basic electronic module ME02 / 8-fold monostable	113
Basic electronic module ME02 / 2-fold bistable	114
Basic electronic module ME03 / 2-fold monostable	115
Basic electronic module ME03 / 4-fold monostable	116
Basic electronic module ME03 / 3-fold 10 mm monostable	117
Basic electronic module ME03 / 2-fold bistable	118
BASIC PNEUMATIC MODULE	119
Basic pneumatic module with integral pressure shut-off	120
VALVES	121

MODULAR ELECTRICAL / PNEUMATIC AUTOMATION SYSTEM TYPE 8644 AirLINE

AirLINE Type 8644 is an electrical and pneumatic automation system which has been developed for use in control cabinets or boxes. In a through system, all electronic and pneumatic components are standardized so that if simple rules are complied with, electrical and electronic modules of differing functionality may be combined in a very simple manner. All components are connected via a snap-on mechanism. This includes the necessary electrical connections. In this way, for example, valves and power outputs may be combined with only one field bus connection. A number of electrical modules (terminals) may be combined very simply with valves mounted on special pneumatic modules (valve units).

Features

Characteristics of AirLINE are:

- Simple handling
- Functional block construction of switched box or cabinet.
- Automatic build-up of potential groups, current, data and safety circuits.
- Combination of valve units and terminals in differing cluster size (2-fold, 4-folds, ...) for space and price optimized station construction.

Advantages

This principle brings the following advantages:

- Flow-optimized valve structure
Pressure range from vacuum to 10 bar
Flow rates of approx. 300l/min or 700 l/min with a valve width of 10 mm and/or 16 mm.
- Integration of non-return valves into the pneumatic base module (optional).
- High service life through rocker technology with oiled and non-oiled air.
- Simple combination of different functions, configuration and extension through high level of modularity.
- Numerous valve functions: 3/2, 5/2 (monostable, bistable) and 5/3 way functions.
- Mechanical Manual-Emergency operation.
- Different pressure levels possible in a single chain.
- Integration of pressure gauges for display of the operational pressure.
- Central compressed air supply via connection modules possible on both sides, as well as intermediate supply.

Design of the system

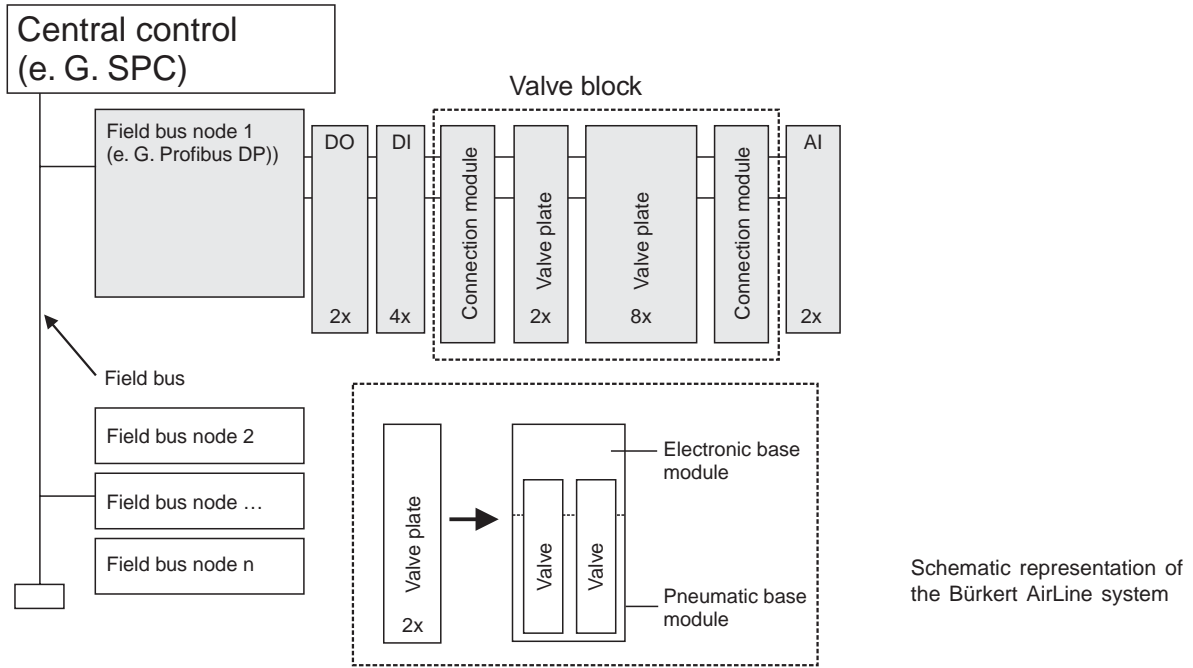
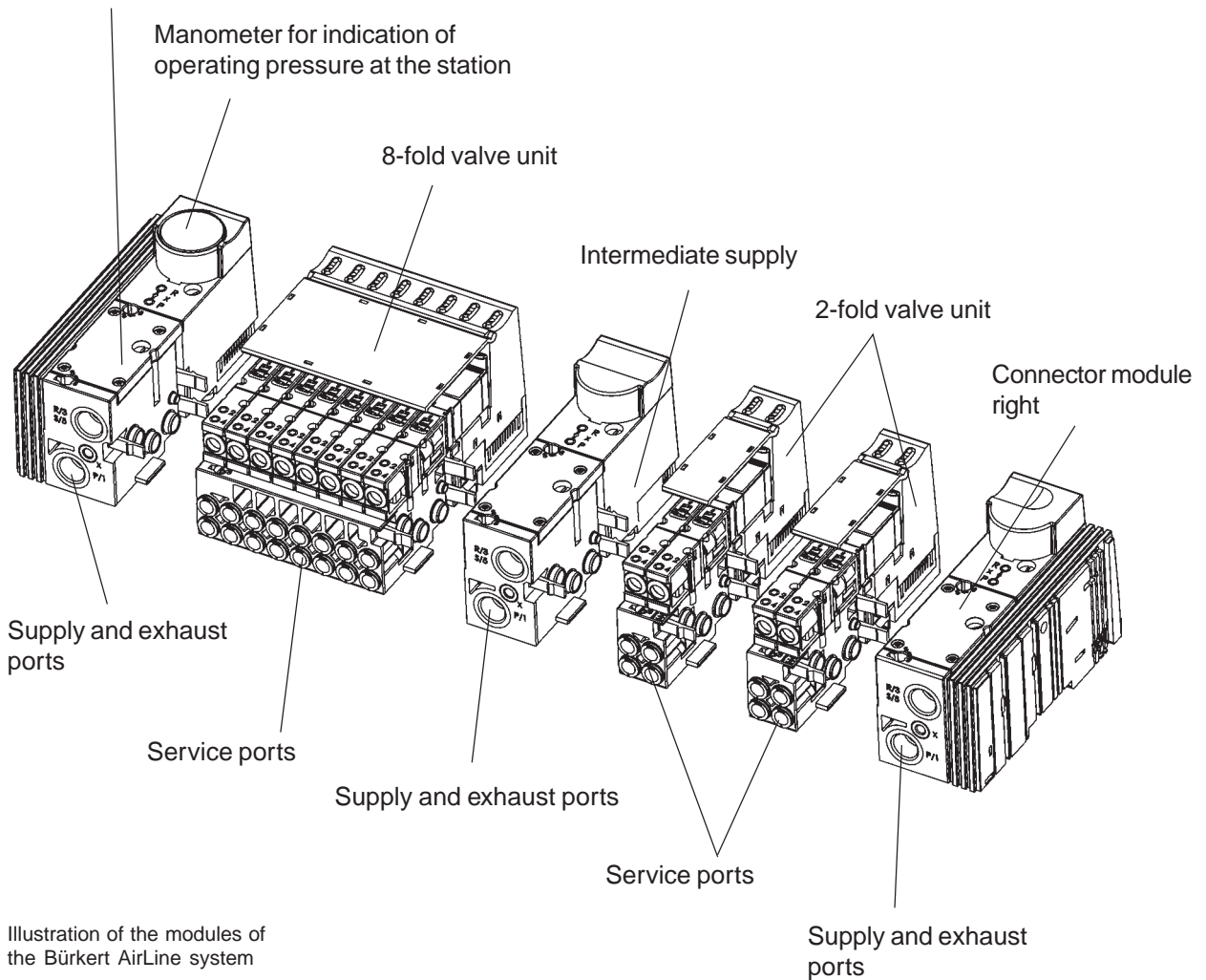

Illustration of the valve block

Connector module left



System description

In its minimal configuration, the system consists of field bus nodes and the Valve block.
 The closing plate protects both the system and persons from improper contact.
 Terminals can be arranged before and after the valve block

Procedure for changing the electrical function module:



ACHTUNG!

Do not introduce foreign parts into the basic module (24V supply bus)-
 -> Risk of short circuit

- Switch off the electricity and compressed air supplies to the AirLINE system
- Unscrew fixing screws of the valves with a screwdriver
- Pull valve off valve plug
- Keep dirt away from flange seal and O-ring (3/2 valve)
- Loosen the functional module at the rear latching mechanism and pull away upwards from the distributor module (backplane bus) without tilting it.
- Set the new functional module vertically on the distributor module (backplane bus) and press downwards until it can be heard to latch in.
- Place valve with clean inserted flange seals/O-rings onto the valve position and tighten the screws according to the adjacent assembly drawing.

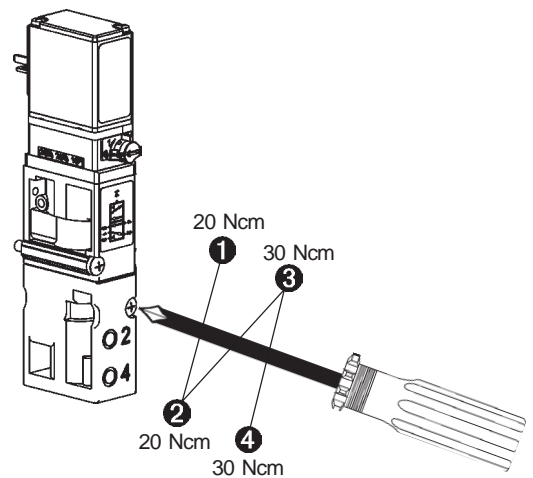

VALVE BLOCK

The valve block is composed of the following modules:

- **Connector modules/supply units** (collective ports for supply, exhaust and auxiliary control air)
- **Valve units** (service ports, miscellaneous valves)

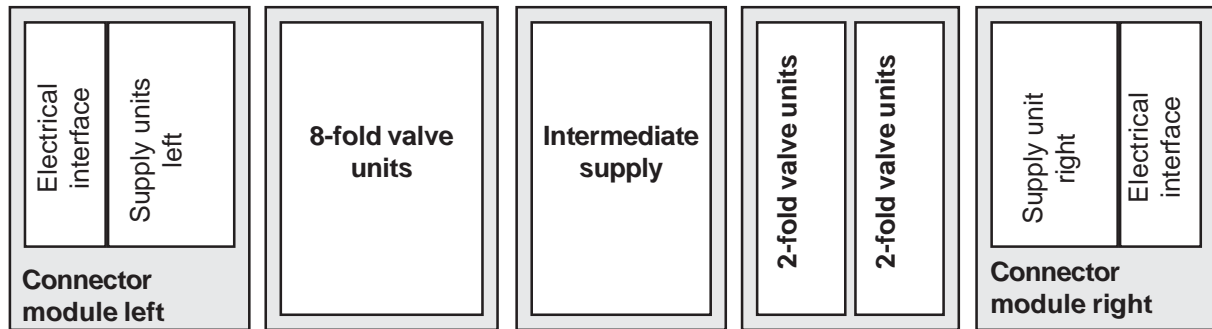

Example of a valve block, schematic

Viewed from the outside, the pneumatic automation system represents a closed electrical unit. Owing to the modular construction, the number of internal bus participants and the current consumption of the valve block may vary. The valve block and each electrical module/terminal provide a standardized electrical interface to the outside.

Connector modules / feeders

Feeders in the form of pneumatic connector modules form the fluidic interface between the supply line and the internal supply structure. The fluid is passed on via the feeder from one valve unit to the next. In order that the supply pressure remains almost constant over the entire path, additional feeders may be necessary. It is recommended to insert a feeder after 24 (ME02) or 16 (ME03) valve positions. The use of intermediate feeders also enables segments to be built up when the pneumatic channels are closed between individual valve units.

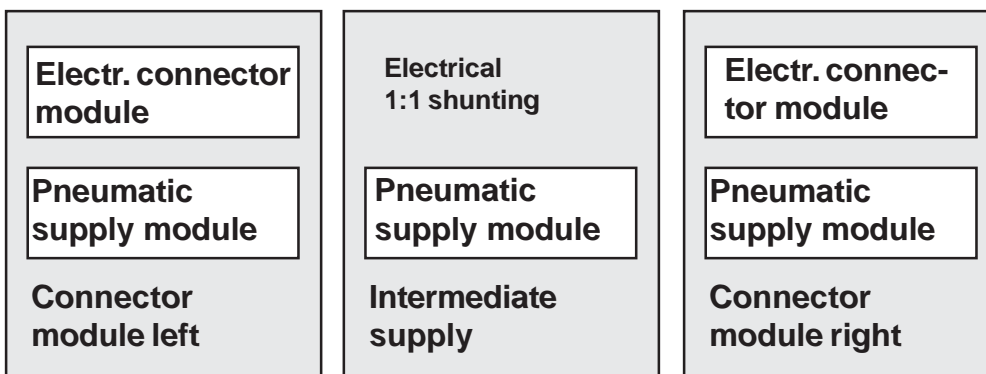

Schematic representation of supply

VALVE UNITS

Construction

Valve units are of modular construction and consist of:

- Basic electronic modules
- Basic pneumatic modules
- Valves

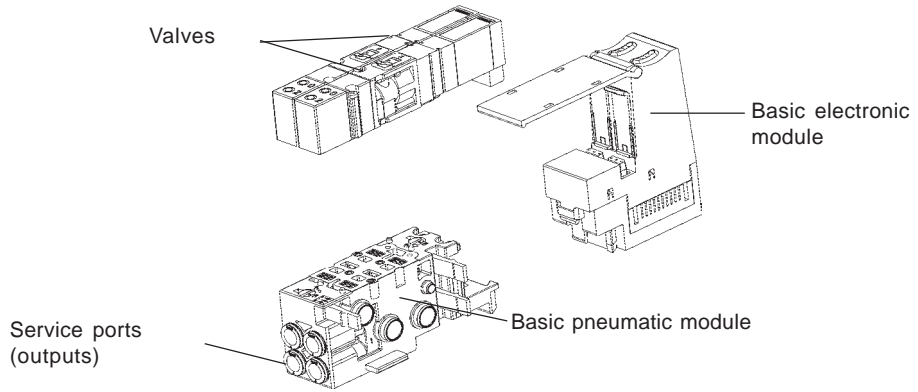

Modular construction of the valve units

The digital outputs, on which the valves sit, are switched on the basic electronic module. Depending on the function, these switch the internal P channel to the service ports (outputs) of the pneumatic module.



ATTENTION!

Plugged-on valves may only be changed if the pressure in the AirLINE is relieved. If a pressure shut-off is used, the valves may also be exchanged under pressure.

Variants

The modular construction of the valve units permits of several variants.

Types: pneumatic / electronic	MP11/ ME02	MP12 / ME03
Add-on dimension	11 mm	16,5 mm
Valve types	6524 6525 0460	6526 6527 0461
No. of valve positions on basic electronic module	2fold ---- 8fold	2fold 3fold* 4fold
No. of valve positions on basic pneumatic module	2fold 8fold	2fold 3fold* 4fold
Connection type (on basic pneumatic module)	D6 D4 D1/4" M5 M7	D8 G1/8" NPT 1/8" D4 D1/4 D6** M5** M7**
Non-return valve (optional)	Without non-return valve Non-return valve in R channel Non-return valve in R+S channel	
Pressure shut-off (optional)	With pressure shut-off***	not available

* Width of basic electron/pneumatic module = 33 mm, with 3 plug-on positions for 10 mm valves 6524 / 6525

** Special version 3-fold, 10 mm valves

*** Available only for certain valve types and with functional limitation.

See also the technical data of the valve block and the description of the basic pneumatic module.



NOTE

You can obtain information about the correct assembly of modules, valves and accessories via our Configurator. If you have any questions, please consult our Distribution Center.

Technical data of the valve block

(using electronic modules and valve types 6524, 6525, 6526, 6527, 0460, 0461)

Mounting dimension	11 mm		16.5mm	
Valve operation	C/D (3/2-way) Type 6524	L/N (5/3-way) Type 0460	C/D (3/2-way) Type 6526	L/N (5/3-way) Type 0461
	H (5/2-way) Type 6525	H (5/2-pulsed) Type 0460	H (5/2-way) Type 6527	H (5/2-pulsed) Type 0461
Flow	300 l/min	200 l/min	700 l/min	500 l/min
Pressure range (with pressure shut-off)	2,5 - 7 bar	2,5 - 7 bar	2 - 10 bar	2,5 - 7 bar
	5 - 7 bar	-	-	-
Power	1 Watt	2 x 1 Watt	1 Watt / 2 Watt	2 x 1 Watt
Current (before / after power reduction)	43/26 mA	38/ - mA	42/33 mA / 96/48 mA	38/ - mA
Valve places (max.)	64	32	32	24
Electrical module	2; 8	2 bistable	2; 4; 3*	2 bistable
Pneumatic module	2; 8	2 bistable	2; 4; 3*	2 bistable
Protection Class in (in terminal model)	IP 20	IP 20	IP 20	IP 20
Ambient temperature	0 to +55°C	0 to +50°C	0 to +55°C	0 to +50°C
Storage temperature	-20 to +60°C	-20 to +60°C	-20 to +60°C	-20 to +60°C
Nominal operating mode	Continuous operation (100 % ED)			
Operating voltage	24 V / DC; -15 +20 % tolerance**; residual ripple at field bus interface 5 %			
Protection Class	3 according to VDE 0580			
Total current	Dependent on the connection technology, the expansion stage and the control			

Interface (Profibus)

Profibus	Copper conductor (RS-485), connected via Profibus connector; Power supply potential separated; screen electrically connected to the functional earth
Recommended cable lengths	see Profibus system data

Local bus

No. of connectable AirLINE terminals	
Limited by software	max. 64
Limited by power supply unit	max. logic current consumption of connected local bus module: $I_{max} \leq 2 \text{ A DC}$



ATTENTION!

Observe current consumption of the modules!

On project planning of an AirLINE station, observe the current consumption of the logic of each participant! This is given in each module-specific data sheet. It may differ from module to module. Hence the number of possible participants that can be connected depends on the specific construction of the station.

*3 x 10 mm valves for add-on dimension 16.5 mm
 ** in the case of the EEx n version, maximum +10 %

Technical data for the complete system

Voltage supply:

Rated voltage	24 V/DC
Tolerance	- 15% / + 20%
Valve types 0460, 0461	- 10% / + 10%

Current carrying capacity:

Contacts	max. 8 A
Valve block (via connector module left)	max. 2.5 A

Maximum current consumption:

Logic current	$I_{Log} = I_{Log_FBKN} + \Sigma I_{Modul}$
I_{Log}	Current consumption logic range
I_{Log_FBKN}	proportional current in field bus nodes max. 1.25 A/DC (0.75 A/DC for logic supply; 0.5 A/DC for analog voltage supply)
I_{Module}	proportional current logic range of the elec. base module max. 15 mA
I_{Valve}	Valve current - before and after power reduction

Valve type	Valve current	
	before power reduction	after power reduction
6524	43 mA	26 mA
6525	43 mA	26 mA
6526	96 mA	48 mA
6527	96 mA	48 mA
0460	38 mA	-
0461	38 mA	-

Temperature:

Storage temperature	- 20 to + 60 °C
---------------------	-----------------



NOTE

The admissible ambient temperature is depend on the modules used. During assembly, the crucial factor is the most critical module.

Field bus nodes Profibus DP (standard)	0 to + 55 °C
Valve type 6524, 6525, 6526, 6527	0 to + 55 °C
Valve type 0460, 0461	0 to + 50 °C

FIELD BUS NODE PROFIBUS DP

Description of the field bus node Profibus DP / technical data

The bus terminal couples an AirLINE station to the Profibus and provides the supply voltages for the connected participants.

Features:

- Profibus connection using copper technology
- Data rate: all defined transmission rates up to 12 MBd
- Error diagnosis through LEDs on the bus terminals
- Galvanic isolation of the field bus



NOTE

Profibus DP / DPV1 field bus node

The field bus node has expanded functions in DPV1 mode from serial number 37344 onwards.

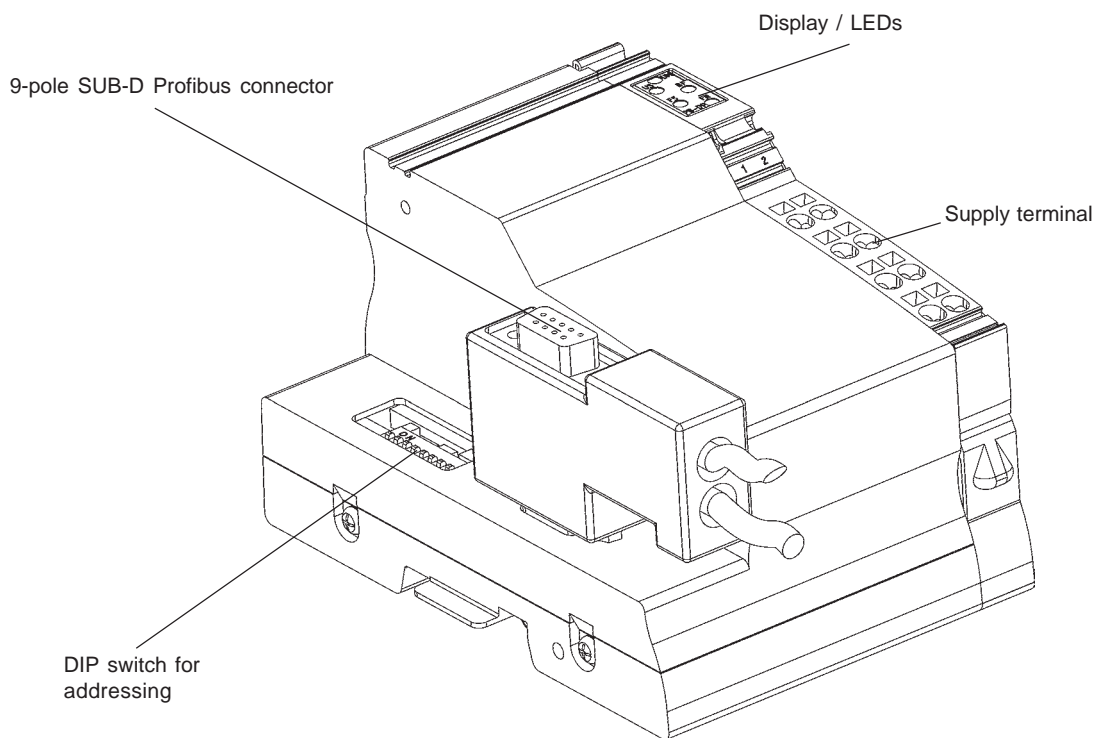

NOTE

The Profibus plug is not included in the delivery. Please order the plug according to the ordering data in the data sheet.

The cover plate is included with the bus terminal. Use this plate to terminate the AirLINE station. The cover plate has no electrical function. It protects the station from ESD pulses and the user from touching dangerous voltages.

Special features with DIP switch 8

As is not the case for the PROFIBUS bus terminal up to serial number 37343 (GSD file: BUER00F0.gsd, device entry: „Typ8644“), for new devices from serial number 37344 onwards DIP switch 8 will no longer be used for setting the stop behaviour, but for differentiating between DPV0 and DPV1 mode.

For new devices, stop behaviour is set via the parameter telegram:

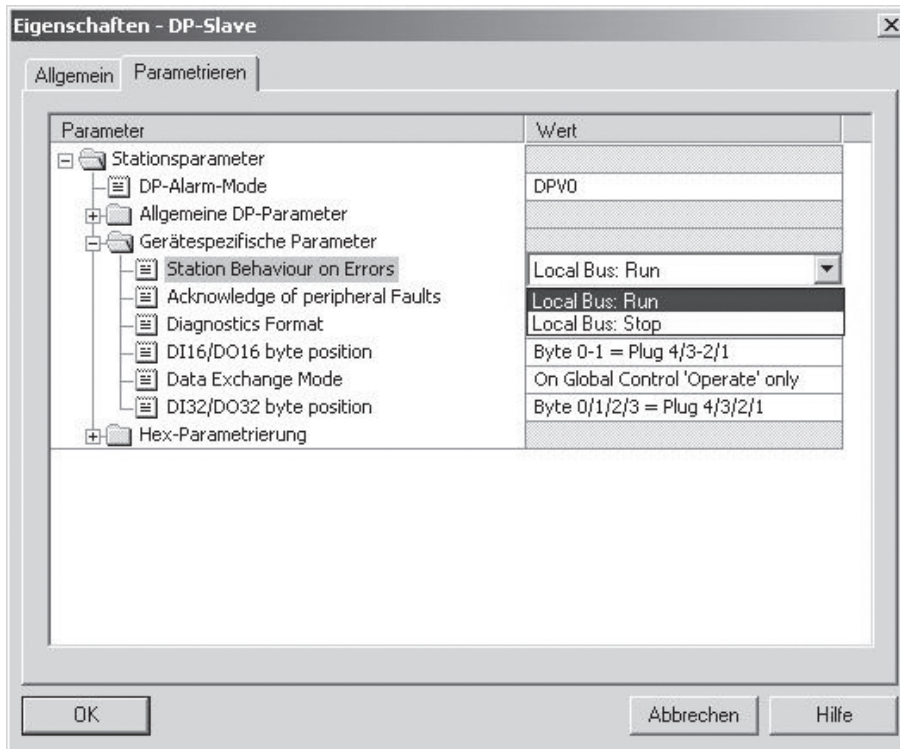

DIP switch 8 - Position OFF (default setting)

The device is exchange-compatible with the predecessor up to serial number 37343 and provides the following new functions:

- acyclical communication with e.g. RS232 modules, including in the process data channel
- various diagnosis formats
- acknowledgement of peripheral errors from the application program
- adaptation of the high-byte/low byte format to the control format on 16 and 32-channel input and output modules.

These functions are, however, only available on new devices from serial number 37344 onwards.

When scheduling projects for the device, use the „BUER00F0.gsd“ GSD or the device entry „8644-DPV1(DIP8=OFF) ME02“ in the S7 hardware configurator.

DIP switch 8 - Position ON

The device provides all new functions in the ON position.

Stop behaviour, which was set via DIP switch 8 in the old device, is now adjusted via parameterization.

When scheduling projects for the device, use the „BUER06BA.gsd“ GSD or the device entry „8644-DPV1(DIP8=ON) ME02“ in the S7 hardware configurator.

POWER LOSS

Formula for calculation of the power loss of the electronics

$$P_{EL} = P_{BUS} + P_{PERI}$$

$$P_{EL} = 2,6 \text{ W} + \left(1,1 \frac{\text{W}}{\text{A}} \times \sum_{n=0}^a I_{Ln}\right) + \left(0,7 \frac{\text{W}}{\text{A}} \times \sum_{m=0}^b I_{Lm}\right)$$

Where

P_{EL} Total power loss in the terminal

P_{BUS} Power loss for bus operation without peripheral loading (constant)

P_{PERI} Power loss with periphery connected

I_{Ln} Current consumption of participant n from logic supply

n Index designating the number of participants connected ($n = 1$ to a)

a Number of participants connected (supply with logic voltage)

$\sum_a I_{Ln}$ Sum of all current consumed by participants from the 7.5 V logic supply (max. 2 A)

$\sum_{m=0}^b I_{Lm}$ Current consumption of participant m from analog supply

m Index designating the number of analog participants connected ($m = 1$ to b)

b Number of analog participants connected (supply with analog voltage)

$\sum_{m=0}^b I_{Lm}$ Sum of all current consumed by participants from the 24 V analog supply (max. 0.5 A)

Derating

Substituting the maximum currents of 2 A (logic) and 0.5 A (for analog terminals) in the formula for calculation of the power loss with periphery connected, we obtain:

$$P_{PERI} = 2.2 \text{ W} + 0.35 \text{ W} = 2.55 \text{ W}$$

This 2.55 W corresponds to 100 % network loading capacity in the derating curves.



ATTENTION!

Make sure that at an ambient temperature above 40 °C, the nominal loading capacity given by the derating curves is not exceeded. As can be seen from the formula, the total loading with attached periphery (P_{PERI}) is the relevant quantity. If for example no current is consumed by the analog supply, the fraction of the current from the logic supply may be greater.

Derating of the logic power supply and the power supply of the analog terminals

- At a current loading of the peripheral supply at the bus terminal of max. 8 A

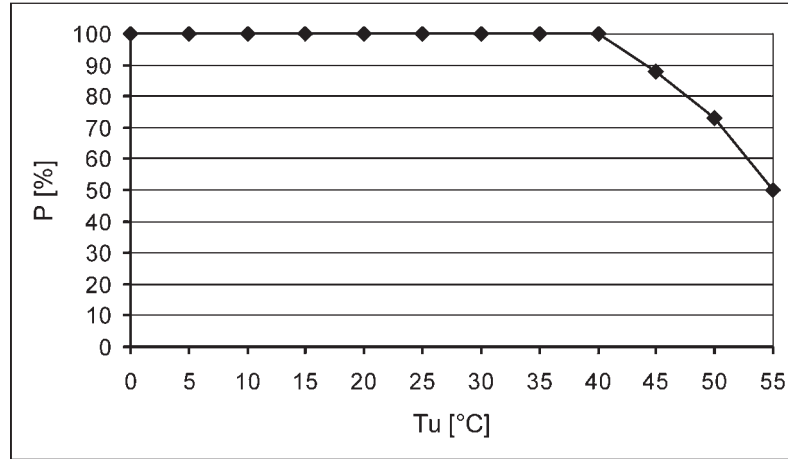

P [%] Loading capacity of the logic and analog power supplies in %
 Tu [°C] Ambient temperature in °C

- At a current loading of the peripheral supply at the bus terminal of max. 4 A

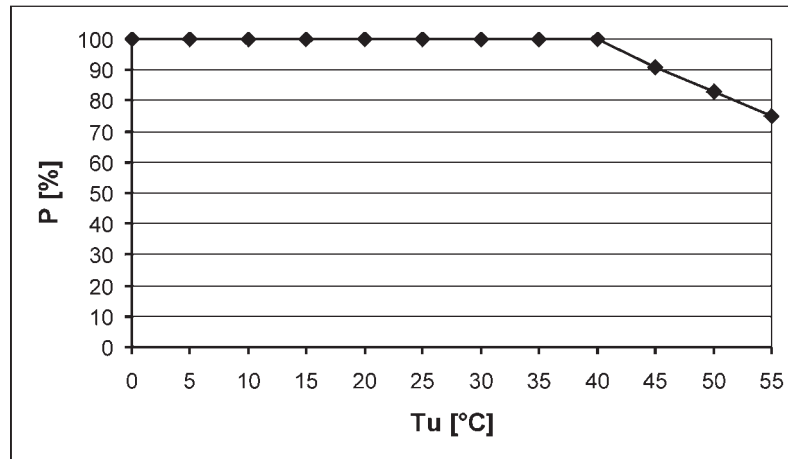

P [%] Loading capacity of the logic and analog power supplies in %
 Tu [°C] Ambient temperature in °C

Example:

Current loading of periphery supply: 8A
Ambient temperature: 55 °C

1. Nominal loading capacity of the logic and analog supply: 50 % (from graph)

$$I_{L\text{Logik}} = 1 \text{ A}, I_{L\text{Analog}} = 0.25 \text{ A}$$

$$P_{\text{PERI}} = 1.1 \text{ W} + 0.175 \text{ W}$$

$$P_{\text{PERI}} = 1.275 \text{ W (equals 50 \% of 2.55 W)}$$

2. Possible logic current when analog supply is not loaded:

$$P_{\text{PERI}} = 1.1 \text{ W/A} \times I_{L\text{Logik}} + 0 \text{ W}$$

$$P_{\text{PERI}} / 1.1 \text{ W/A} = I_{L\text{Logik}}$$

$$I_{L\text{Logik}} = 1.275 \text{ W} / 1.1 \text{ W/A}$$

$$I_{L\text{Logik}} = 1.159 \text{ A}$$

Protective features

Overvoltage
(segment supply /main supply)

Protective diodes at input (destroyed on continuous overloading)

Loading peaks up to 1500 W are short-circuited by the input diode.

False polarity
(segment supply /main supply)

Parallel polarity protection diodes; in case of error, the high current through the diodes causes the upstream fuse to blow.

Common potentials

Main and segment supply lie electrically at the same potential. Their common mass is led from the bus terminal via the potential shunter as reference mass GND to the participants.

Analog supply and 7.5 V logic supply are generated from the main supply. Their common mass LGND lies electrically at the same potential as GND and is led from the bus terminal via the potential shunter as reference mass LGND to the participants.

Technical data of the field bus module Profibus DP bus node

Connection technique	Tension spring terminals	
Recommended cable lengths	max. 30 m; cable routing over free areas not permissible	
Forwarding	Via potential shunting	
Behaviour on voltage drop and interruption	The voltages forwarded from the bus terminal to the potential shunters (main and segment voltage) follow the applied supply voltages without delay.	
Rated voltage	24 V DC	
Tolerance	- 15 % / + 20 % (to EN 61131-2)	
Ripple	± 5 %	
Permissible range	19.2 V to 30 V	
Current loading	Max. 8 A	
Min. current consumption at rated voltage main power supply	0.10 A DC (at open circuit, i.e. incoming remote bus attached, no local bus participants connected, bus inactive)	
Max. current consumption at rated voltage main power supply	1.25 A DC	consisting of: 0.75 A DC for logic supply 0.5 A DC for analog voltage supply
Protective features		
Overvoltage	yes	
False polarity	yes	



ATTENTION!

Protect 24 V section externally!

This 24 V section must be protected externally with a fuse. The power supply unit must be capable of supplying 4 times the rated current, so that in case of a fault, blowing of the fuse is assured.

Minimize heat generation!

For supplying the main voltage and for supplying or tapping the segment voltage, use both adjacent contacts.

Observe current carrying capacity!

The maximum cumulative current through the potential shunter is 8 A.

Technical data of the field bus Profibus DP node

Housing dimensions (width x height x depth)	48,8 mm x 120 mm x 71,5 mm
Weight	210 g (without plug)
Permissible temperature (storage/transport)	-20 °C to +60 °C
Permissible air humidity	75% mean, 85% occasionally

**ATTENTION!**

In the range of 0 to +55 °C, suitable precautions must be taken against elevated humidity (> 85%).

Slight condensation of short duration on the outside of the housing is permissible, e.g. when the terminal is brought from a vehicle into a closed room.

Permissible air pressure (operation)	80 kPa to 106 kPa (up to 2000 m üNN)
Permissible air pressure (storage/transport)	70 kPa to 106 kPa (up to 3000 m üNN)
Protection type	IP 20 to IEC 60529
Protection class	Class 3 to VDE 0106, IEC 60536

Installation and electrical commissioning of the field bus node Profibus DP

The Profibus bus node

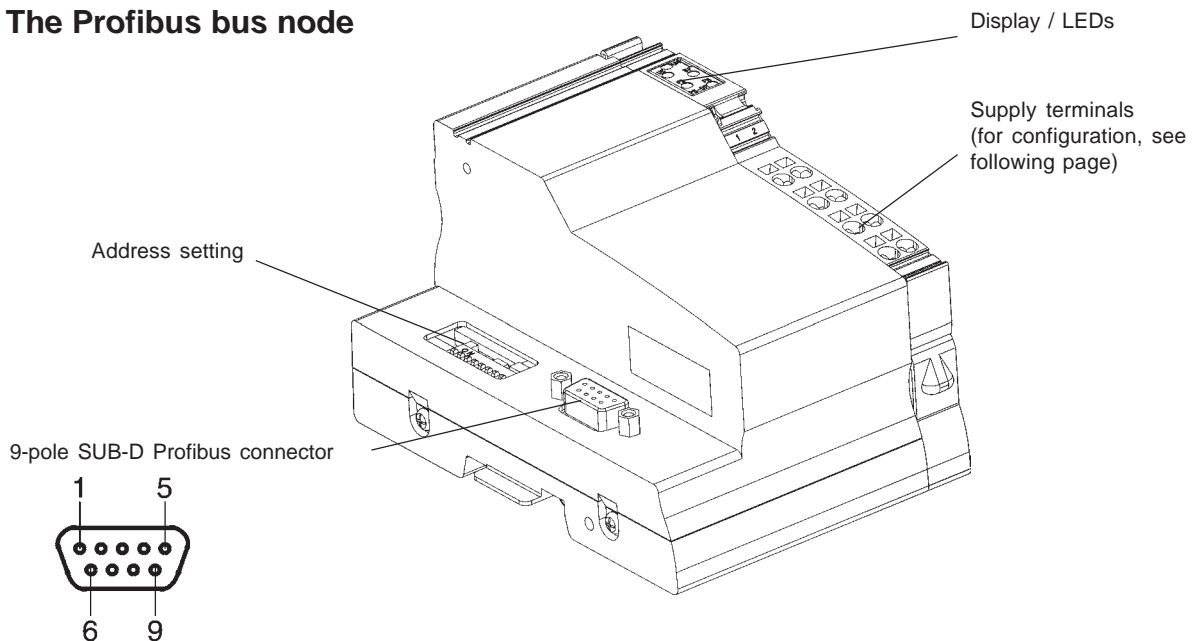

Configuration of the 9-pole SUB-D connector

As a general rule, a 9-pole SUB-D connector with pins is used in the PROFIBUS. In the profibus DP field bus coupler, the matching part (socket) is always present. In the first and last plugs of a segment, a closing resistor of 220 ohm and two terminating resistors of 390 ohm must be present. The A line (RxD/TxD-P) is always earthed via one terminating resistor, the B line (RxD/TxD-P) is always connected to +5V via the other one. These resistors must be provided in the plug (e.g. Phoenix Contact SUNCON-PLUS-PROFIB, Art. no. 27 44 34 8).

Pin No.	Designation (socket in device, plug on cable)	Meaning
1	n. c.	-
2	n. c.	-
3	RxD / TxD-P	Receive / send data P (+) (conductor B)
4	CNTR-P	Control signal for repeater (+), direction control
5	DGND*	Reference potential of 5 V
6	VP*	Supply voltage + 5 V for closing resistors
7	n. c.	-
8	RxD/TxD-N	Receive / send data N (-) (conductor A)
9	n. c.	-

* Removal of potential separation

Separate potentials

The interface supply for the Profibus has a separate potential from that of the power supplies. When using an LWL converter, the voltage shut-off to the 5 V logic supply to the bus terminal can be cancelled via DIP switches 9 and 10. This makes the higher current required for operating the LWL converter available at the interface.

Terminal configuration of the power supply terminal

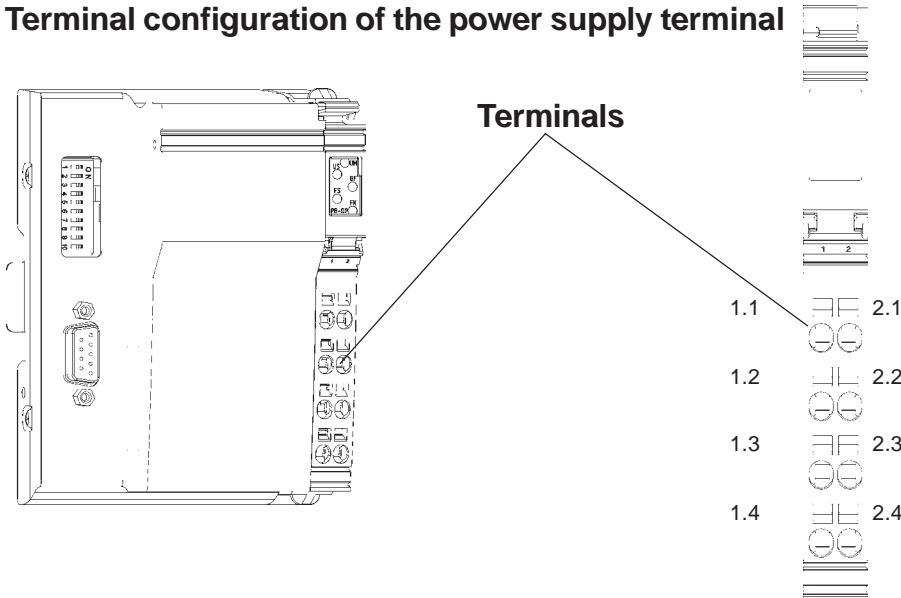

Configuration of the terminal points

Left	Right	Colour	Abbrev.	Meaning
1.1	2.1	black	U _S	Segment supply (+24V DC)
1.2	2.2	red	U _M	Main, bus, logic and interface supply (+24V DC)
1.3	2.3	blue	GND	Reference potential
1.4	2.4	---	FE	Functional earth



ATTENTION!

Earth (ground) the bus terminal!

Earth the bus terminal via one of the FE connections of connector 1.3 or 2.4. For this purpose, connect the relevant contact to an earthing terminal.

24 V segment power supply / 24 V main power supply

The reference potential of the segment power supply must be the same as that of the main power supply. Hence no separate potential structure is possible on the periphery side.

The main power supply and the segment power supply are equipped with elements for protection against false polarity and transient overvoltage.

24 V segment power supply

You can supply or generate the segment voltage at the bus terminal or one of the supply terminals. There are several options for providing the segment voltage at the bus terminal:

- You can supply the segment voltage at the terminal points 1.1/2.1 and 1.3/2.3 (GND) of the power supply connector separately.
- You can bridge the connections 1.1/2.1 and 1.2/2.2 to assure supply of the segment circuit from the main circuit.
- With a switch between terminal points 1.1/2.1 and 1.2/2.2, you can build up a switched segment circuit (e.g. also an EMERGENCY OFF circuit).

Electrical installation of the field bus node Profibus DP

**ATTENTION!**

Electrical wiring shall not be connected under voltage!

Connection of the electrical inputs and outputs (terminals)

- Open the plug contact with a screwdriver.
- Insert the cable.
- Pull out the screwdriver.
The cable is connected.

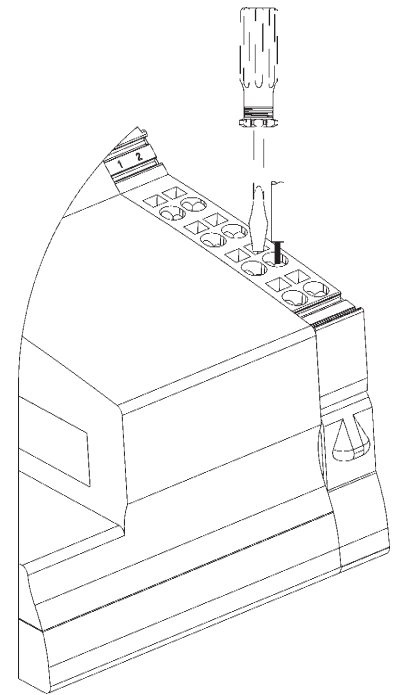
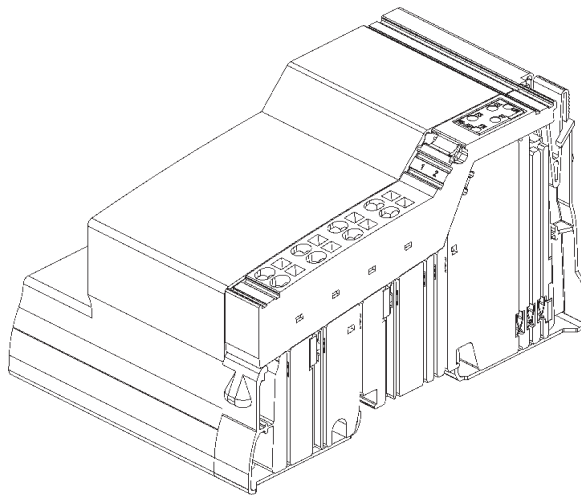

DIP switches

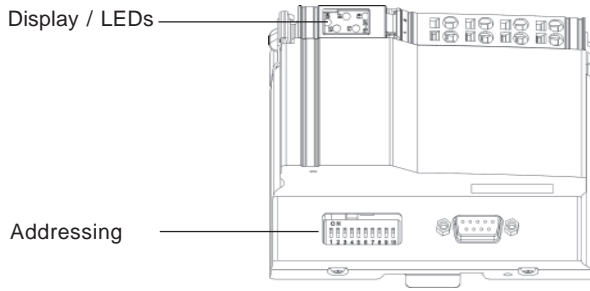

The PROFIBUS address and the behaviour of the PROFIBUS terminal can be adjusted by using the 10 x DIP switch.

The relevance of DIP switches for the PROFIBUS bus terminal from serial number 37344 onwards can be ascertained in the following table.

Configuration of the 10-fold DIP switch

DIP switch	Meaning
1 ... 7	PROFIBUS address in binary display (0 to 127 in decimal display) Switch 1 establishes the least significant bit (LSB) (2^0) Switch 7 establishes the highest significant bit (HSB) (2^6)
8	Inline station operating mode: ON: New mode with DPV1 support, security values and parameterization; OFF: Compatible mode (to PROFIBUS bus terminal up to serial number 37343)
9 ... 10	When an LWL plug connector is used, both switches are set to ON to allow for the increased current requirements of the LWL connector. The interface power supply is then no longer isolated in potential.



NOTE

You will find a detailed illustration of individual functions under *field bus node PPROFIBUS-DPV1 / Description of field bus node.*

Diagnosis LEDs directly on the station

Abb-rev	Colour	Meaning	Explanation
UM	green	Main supply	Supply voltage in main circuit for field bus nodes, logic supply and interfaces present.
US	green	Segment supply	Supply voltage present in segment circuit.
BF	red	Bus Fault	No data exchange with master.
FS	red	Failure Select	Select function of LED FN: FS lights: FN show the error type. FS does not light: FN show the error number.
FN	red	Failure Number	The number of flashes indicates the error type of error number, depending on whether FS lights or not.

Configuration of the Profibus DP bus node

Modules from the GSD file

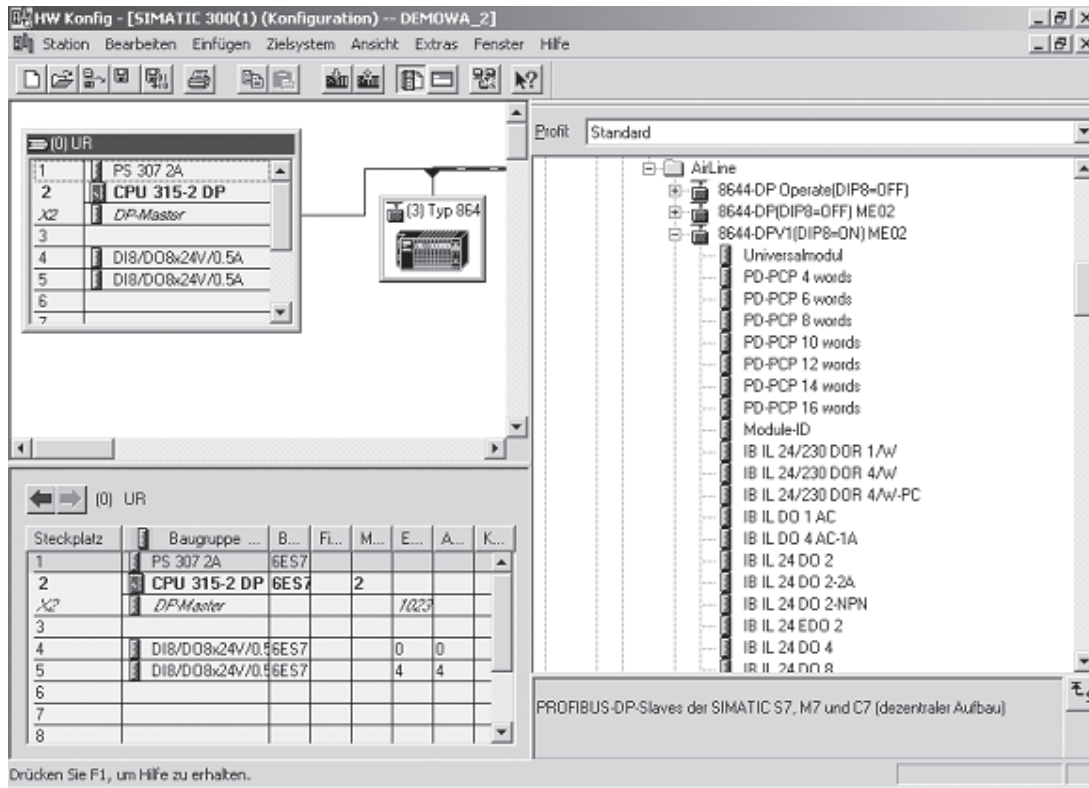

NOTE

Attachment modules are "passive" and are not configured.
 "Valve discs" summarized analogously with electrical digital modules.

Addressing in the process diagram 1

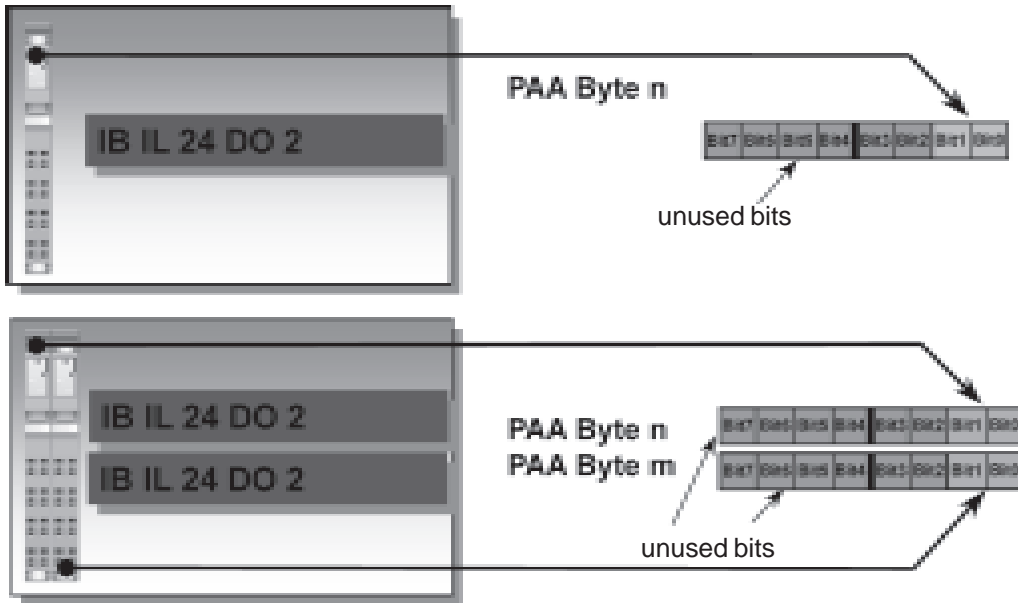

Addressing in the process diagram 2

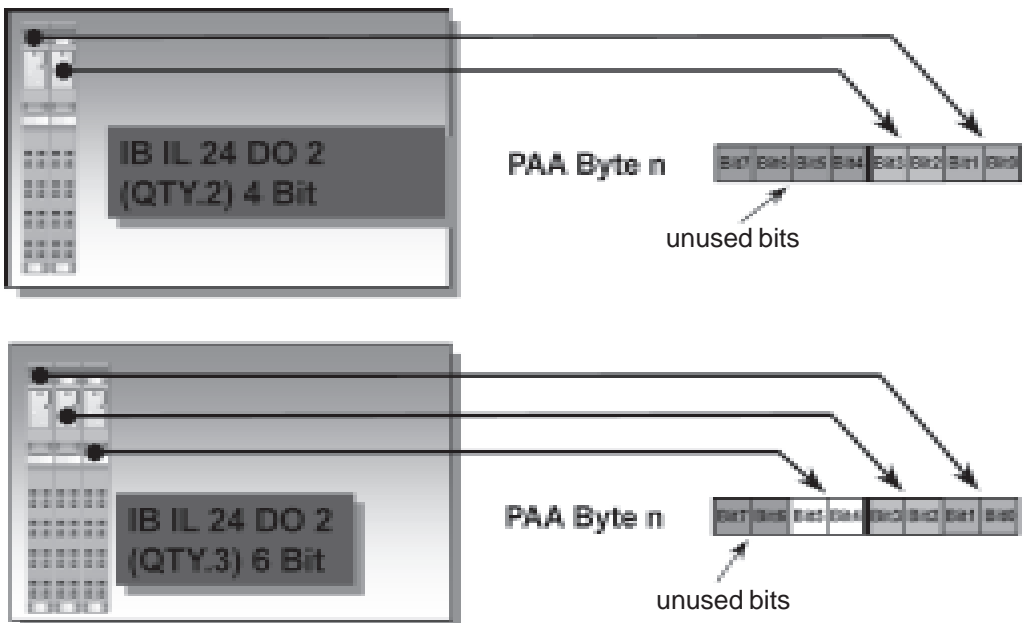

MAN 1000010120 EN Version: K Status: RL (released | freigegeben) printed: 23.04.2025

Addressing in the process diagram 3

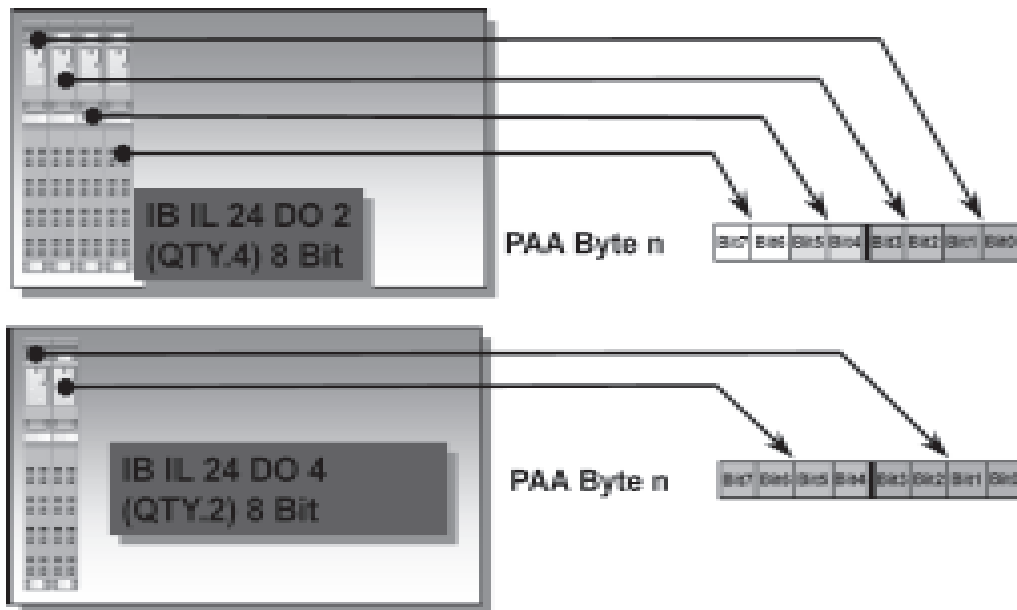

Diagnosis of the Profibus connection

Standard

- Byte** Status 1
- Byte** Status 2
- Byte** Status 3
- Byte** Master Address
- Byte** Manufacturer Identifier

- Byte** Manufacturer Identifier

Device-related

- Byte** Header byte:
- Byte** Diagnosis type: 0x00
- Byte** Software version
- Byte** Error type:
 - 1 - Parameter
 - 2 - Config. Profibus
 - 3 - Config. Interbus
 - 4 - Interbus

- Byte** Error number
- Byte** Module number before error
- Byte** Module number after error
- Byte** ID code
- Byte** Linear code
- Byte** Reserve

MAN 1000010120 EN Version: K Status: RL (released | freigegeben) printed: 23.04.2025

DIAGNOSIS AND ERROR ELIMINATION AT THE PROFIBUS DP BUS NODE

Diagnosis LEDs directly at the station



Abb-rev	Colour	Meaning	Explanation
UM	green	Main supply	Supply voltage in main circuit for field bus nodes, logic supply and interfaces present.
US	green	Segment supply	Supply voltage present in segment circuit.
BF	red	Bus Fault	No data exchange with master.
FS	red	Failure Select	Select function of LED FN: FS lights: FN show the error type. FS does not light: FN show the error number.
FN	red	Failure Number	The number of flashes indicates the error type of error number, depending on whether FS lights or not.

Determining the cause of error

The error type and number may be determined from the LEDs FS and FN, which are to be found above the supply terminal of the field bus nodes. If diode FS lights, the number of flashes of FN shows the error type. If diode FS is off, the number of flashes of FN shows the error number.

Error type and number are simultaneously notified via the PROFIBUS to the control system.

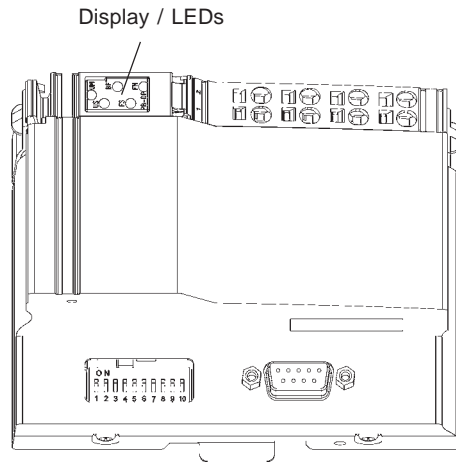
Example:

LED FS lights and LED FN simultaneously flashes three times. Then LED FS extinguishes and LED FN flashes four times (error type 3, number 4). The cause of error is the use of an INTERBUS Loop-1 module which is not permissible.

Error codes during DPV1 communication



ATTENTION!

Error codes during DPV1 communication are errors in relation to DPV1/PCP. During DPV1 communication you will find the error code on byte 3, during communication in the process data channel, error code 1 is located on byte 2 of the response. Pay attention to the individual displays in your working environment at all times.

If there is an error present during DPV1 or PD-PCP communication in relation to an E/A module, this is displayed via 0x44 on byte 2 of the data block.

DPV1 error: Function_Num = 0xDE (Error Read) or 0xDF (Error Write)
 Error_Decode = 0x80 (DPV1 communication)

Error codes during DPV1 communication

Error_Code_1	Error_Code_2	Comment
0xA0	0	Object from the field bus module cannot be read.
0xA1	0	Object from the field bus module cannot be written.
0xB0	0	wrong index from the field bus module
0xB1	0	The PB-PDU length is too small.
0xB2	0	wrong slot
0xB5	0	Module is busy.
0xB7	0	Error while writing on index 47 or 48
0xD1	0	no PCP connection
0xD2	0	Module has no PCP
0xD3	0	Timeout from module
0xD4	0	wrong service
0xD5	0	VC1 sequence not correct
0xD6	0	VC1 length incorrect
0xF..		Error while writing module parameter
0xF1	0	An incorrect module number was used.
0xF2	0	The parameter block is incomplete.
0xF3	0	The data length of the parameter block is too small.
0xF4	0	The data length of the parameter block is too big.
0xF5	0	The internal block for configuration, security value and PCP is too small.
0xF6	0	Header byte from the module parameter block is not correct.
0xF7	0	PCP initialisation for a module that has no PCP functionality.
0xF8	0	too many data blocks for the module

FIELD BUS NODE PROFIBUS DPV1

New functions

As part of the expansion of field bus node Profibus DPV1 (article no. 00148837) new functions have been added and suggestions taken into account:

- DPV1 for category 1 and category 2 masters
- acyclical communication with e. g. RS232 modules, including in the process data channel
- Parameterization of E/A modules
- Failsafe values
- various diagnosis formats
- acknowledgement of peripheral errors from the application program
- adaptation of the high-byte/low-byte format to the control format on 16 and 32-channel input and output modules

Special features of the DIP 8 switches

Position OFF (default setting)

The device is exchange-compatible with the predecessor up to serial number 37343 and provides the following new functions:

- acyclical communication with e.g. RS232 modules, including in the process data channel
- various diagnosis formats
- acknowledgement of peripheral errors from the application program
- adaptation of the high-byte/low-byte format to the control format on 16 and 32-channel input and output modules

These functions are, however, only available on new devices from serial number 37344 onwards.

When scheduling projects for the device, use the „BUER00F0.gsd“ GSD or the device entry „8644-DPV1(DIP8=OFF) ME02“ in the S7 hardware configurator.

Position ON

The device provides all new functions in the ON position.

Stop behaviour, which was set via DIP switch 8 in the old device, is now adjusted via the parameterization.

When scheduling projects for the device, use the „BUER06BA.gsd“ GSD or the device entry „8644-DPV1(DIP8=ON) ME02“ in the S7 hardware configurator.

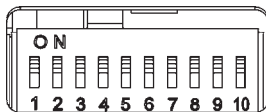

DIP switch assignment

DIP switch settings on PROFIBUS bus terminal from serial number 37344 onwards

DIP switch	Relevance
1 to 7	PROFIBUS address in binary display (0 to 127 in decimal display) Switch 1 establishes the least significant bit (LSB) (2 ⁰) Switch 7 establishes the highest significant bit (HSB) (2 ⁶)
8	Inline station operating mode; ON: New mode with DPV1 support, security values and parameterization; OFF: Compatible mode (to PROFIBUS bus terminal up to serial number 37343)
9 and 10	When using an LWL connector, both switches are on ON in order to take account of the increased current requirement of the LWL connector. There is then no voltage shut-off to the interface power supply.

Overview of firmware functionalities

PROFIBUS	PROFIBUS up to serial number 37343	PROFIBUS bus terminal from serial number 37344 onwards	
		DPV0 mode	DPV1 mode
Device entry	Model 8644	8644-DP (DIP8=OFF) ME02	8644-DPV1 (DIP8=ON) ME02
GSD file	BUER00F0.gsd	BUV100F0.gsd	BUER06BA.gsd
PROFIBUS bus terminal exchangeability old and new version	X	X	--
DPV0 support (cyclical communication)	Maximum 184 bytes Process data	Maximum 184 bytes Process data	Maximum 184 bytes Process data
Operation of PCP modules	--	X	X
DPV1-Read and DPV1-Write support (acyclical communication), Category 1 and category 2 masters	--	--	X
Communication with PCP modules via „normal“ process data (DPV0)	--	X	X
Parameterization of large number of E/A's via dialogues in the project planning tool	--	--	X
Security values set via the project planning tool	--	--	X
Bytes switched round on IB IL24 DI16 and IB IL24 DO16 to adapt to the control format	--	X	X
Bytes switched round on IB IL24 DI32 and IB IL24 DO32	--	New from Firmware B onwards	New from Firmware B onwards
Bus stop acknowledgement, either automatically or via application program	--	X	X
Peripheral error acknowledgement, either automatically or via application program	--	X	X
Diagnosis in the PROFIBUS bus terminal	X	X	X
Diagnosis in the identification format	--	--	X
Diagnosis as status PDU	--	--	X
Stop behaviour can be adjusted via DIP switch	X	--	--
Stop behaviour can be adjusted via parameter telegram	--	X ¹⁾	X ¹⁾
Invoke ID transfer (e.g. for IB IL POS 200)	--	New from Firmware B onwards	New from Firmware B onwards
Dynamic configuration (Reservation of E/A's in the PLC, e.g. for easy expansion)	--	--	New from Firmware B onwards
Station ID can be allocated freely (2 bytes) for improved identification in the network	--	--	New from Firmware B onwards
Failsafe values set via project planning tool	--	--	X

¹⁾ see illustration *Adjusting the stop behaviour on new devices from serial number 3744 onwards*

PROFIBUS	PROFIBUS up to serial number 37343	PROFIBUS bus terminal from serial number 37344 onwards	
		DPV0 mode	DPV1 mode
Device entry	Model 8644	8644-DP (DIP8=OFF) ME02	8644-DPV1 (DIP8=ON) ME02
GSD file	BUER00F0.gsd	BUV100F0.gsd	BUER06BA.gsd
Failsafe values also without connection to PLC	--	--	New from Firmware B
Improved diagnosis of E/A's during start-up	--	--	New from Firmware B
Configuration can be saved (additional verification based on the last valid configuration)	--	--	New from Firmware B

Adjusting the stop behaviour via the parameter telegram

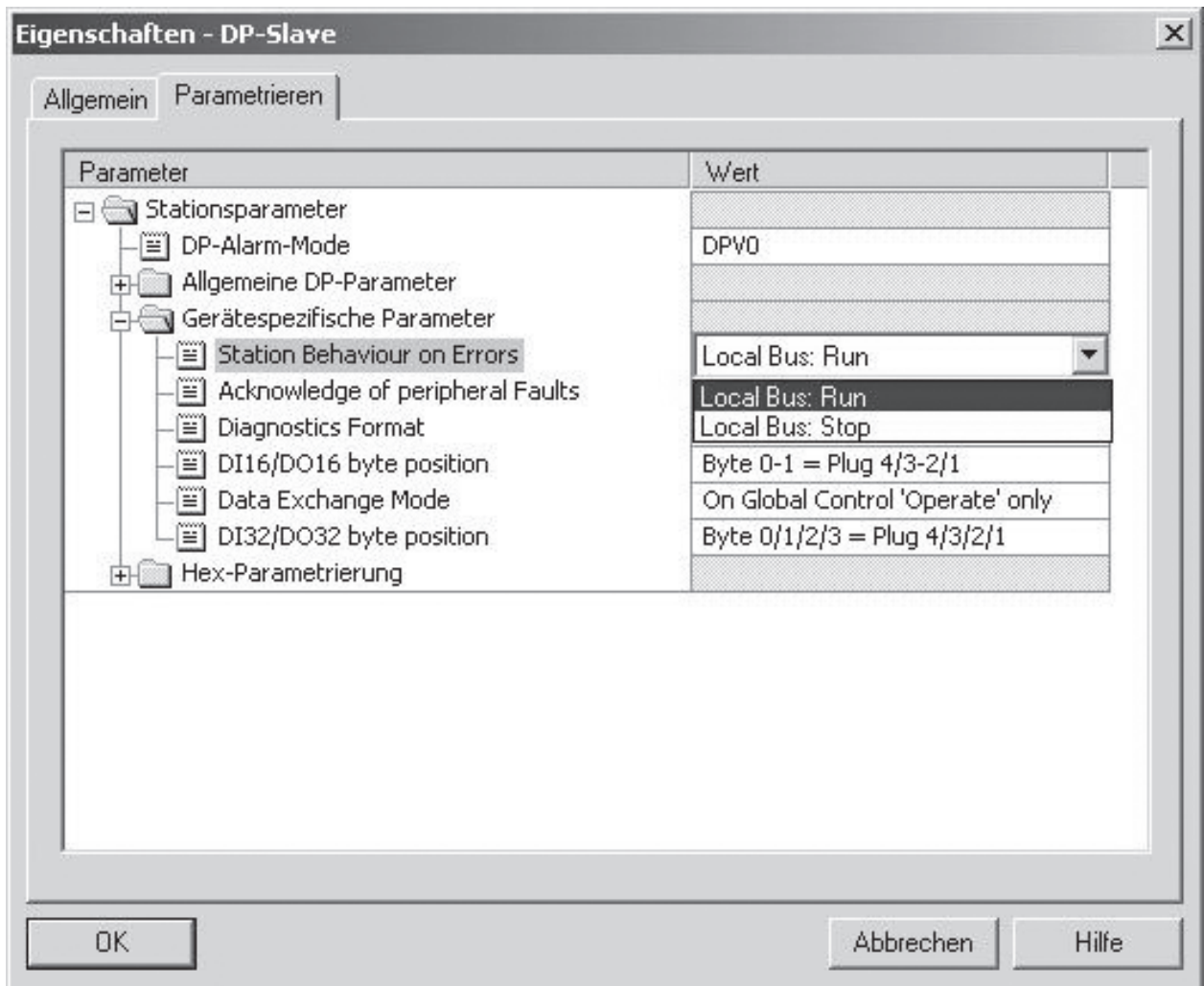

MAN 1000010120 EN Version: K Status: RL (released | freigegeben) printed: 23.04.2025

Description of field bus node

DPV1 is the expansion of the cyclical data exchange according to IEC61158 to acyclical services. Complex devices can be operated easily with this expansion. Acyclical data are particularly suitable for data which do not have to be transmitted on a regular basis or are of variable length, as is the case for example with an RS232 interface.

The following differences can be found:

1. Acyclical communication via the category 1 master (C1 master)

The C1 master carries out the parameterization during slave start-up and is master in the cyclical data traffic. If it necessary to use an RS232 interface acyclically from the C1 master or to read a parameter optionally from the device, corresponding write and read accesses are defined. Since the C1 master is already connected to the slave in the cyclical data traffic, no explicit connection is established, but direct communication can be made with the slave via read and write.

2. Acyclical communication via the category 2 master (C2 master)

The C2 master can be realized in various forms, for example in the form of a display device or control terminal. In the display device, data is fetched by the slave only on request, for example (if a certain parameter is to be read), while accesses are acyclical in the control terminal. Accordingly, write and read accesses are provided for the C2 master. Since the C2 master does not communicate in the cyclical traffic, it must establish and cut the connection explicitly.

3. Acyclical communication in cyclical data exchange (C1 master)

DPV1 is still relatively new. In contrast, the service life of controls and facilities is very long, so that expansions and retrofits can take place. Often, controls are not yet DPV1 compatible, but should be able to operate complex participants. This problem is solved by using the acyclical services within the process data too. That is to say, a control which has no command of DPV1 can control more complex interfaces such as RS232 or HART (via IB IL AI 2/HART) straight away.

Examples

Example module IB IL RS232
 Configuration of station 8644-DPV1 ME02 (Profibus – DPV1-field bus node) – IB IL 24 DI 8 – IB IL 24 DO 8 – IB IL RS232 - IB IL AI 2/SF – IB IL AO 1/SF
 Screenshots created using STEP7, V5.2, Service Pack 1
 Object directories:

Index	Data type	A	L	Relevance	Object name	Rights
5FC1h	Var of Unsigned 8	1	1	Module launch indicator	SART-IND	rd/we
5FE0h	String Var of Octet String	1	58	V24 data	V24 data	rd/we
5FFFh	Array of unsigned 8	20	1	Configuration of the terminal	INIT-TABLE	rd/we

A Number of elements
 L Length of one element in bytes
 rd Read access allowed
 wr Write access allowed

Due to its pre-allocation with defaults and its array configuration, 5FFF, where the details of the protocol are deposited, is a significant example:

Object	INIT-TABLE	
Access	Read-Write	
Data type	Array of Unsigned 8	20 x1Byte
Index	5FFF h	
Sub-index	00 h 01 h 02 h 03 h 04 h 05 h 06 h 07 h 08 h 09 h 0A h 0B h 0C h 0D h 0E h 0F h : 14 h	Describe all elements Protocol Baud-Rate Data width reserved reserved Error pattern First delimiter Second delimiter 3964R priority Output type DTR control Circulation switch XON pattern XOFF pattern reserved : reserved
Length (bytes)	14 h Sub-index 00 h 01 h Sub-index 01 h ... 14 h	
Data	Configuration of terminal IB IL RS 232	

A default is already allocated to the individual elements:

Element		Relevance	Standard settings		Data type
dec.	hex.		Code	Relevance	
1	1	Protocol	00 h	Transparent	Unsigned 8
2	2	Baud rate	07 h	9600 Baud	Unsigned 8
3	3	Data width	02 h	8 data bit, straight Parity, 1 stop bit	Unsigned 8
4	4	reserved	00 h	-	Unsigned 8
5	5	reserved	00 h	-	Unsigned 8
6	6	Error pattern	24 h	(\$)	Unsigned 8
7	7	First delimiter	0D h	Carriage Return (CR)	Unsigned 8
8	8	Second delimiter	0A h	Line Feed (LF)	Unsigned 8
9	9	3964R priority	00 h	low	Unsigned 8
10	A	Output type	00 h	RS 232	Unsigned 8
11	B	DTR control	00 h	automatic	Unsigned 8
12	C	Circulation switch	00 h	no circulation	Unsigned 8
13	D	XON pattern	11 h	-	Unsigned 8
14	E	XOFF pattern	13 h	-	Unsigned 8
15 ... 20	F ... 14	reserved	00 h	-	Unsigned 8

Table: Elements of the object **INITABLE**

The communication protocol for the parameter data in local bus is referred to in the following as PCP. The objects on the DPV1 field bus node:

Slot	Index	Service	Comment
1 ... 63	2	Write	Module parameter
0	3	Write	Control byte (diagnosis format, manual peripheral error acknowledgement ...)
0	4	Write	Acknowledgement (local bus event) 1: Local bus stop acknowledgement 2: Peripheral fields acknowledgement
0	5	Read	Overview of PCP modules and status
1 ... 63	47	Read/Write	PCP data to profile profidrive
1 ... 63	48	Read/Write	PCP data

The intention of these objects is to show how access to an intelligent slave can be obtained via various masters.

DPV1 in the C1 and C2 master



NOTE

Not all controls / configuration tools support DPV1, or only support it with limitations. Check this context before programming the application. If DPV1 is not sufficiently supported, you have the opportunity to use the functions via the cyclical process data channel.

One of the simplest solutions for exchanging data is DPV1 in the C1 master. The connection establishment (Initiate) is omitted, since there is already a connection between master and slave in the cyclical data traffic. Data exchange can be commenced directly.

With C2 communication, the data fields are identical to those of C1 communication. The SAPs (Service Access Points) are 51 for C1 communication, for C2 communication 48 and 50 (49 for the connection establishment). Connection establishment (Initiate) or connection termination (Abort) via SAP 49 and 50 between master and slave should be regarded as an additional effort. Use DPV1 devices so that the routines for connection administration are easy to realize.

Only one active DPV1 is ever permitted. Overall you have the opportunity to connect up to eight PCP capable terminals / modules to the DPV1 field bus node.

The process

Note that the PCP data of the I/O modules are mainly addressed via 16 bit long object indices. Unfortunately DPV1 only provides fields for 8 bit long indices. Therefore, drawing on the PROFIDrive profile a sequence of 2 (4) steps has arisen:

Read (Write/Polling - Read/Polling)

1. a) Dispatching the request as write (read) to slot x.
b) Polling the answer onto the write (read)
2. a) Dispatching a read to slot x
b) Polling the answer onto the read

Write (Write/Polling - Read/Polling)

1. a) Dispatching the request as write (write) to slot x.
b) Polling the answer onto the write
2. a) Dispatching a read to slot x
b) Polling the answer onto the read

Depending on the programming and runtime environment, polling for the answer to a read and write is done by this environment. The write/read combination is therefore sufficient.

Take care to ensure that you always obtain the answer with a read when communicating with the 16 bit long object indices of the E/A modules. Otherwise, the DRV1 error code 80 B5 00 ("the module is busy") will show on the next communication. In this case, this means that the answer from the last communication still needs to be picked up. This will be waited for.

Communication is made for accesses to E/A modules via the DPV1 index 48, the object and sub index of the E/A module is transferred integrally as part of the data field.

When communicating with objects which are deposited on the DPV1 field bus node itself, reading and writing can be done with a sequence of 1 (2) steps, since the indices are only 8 bits long.

Read (Read/Polling)

1. a) Dispatching a read on slot x
- b) Polling the answer onto the read

Write (Write/Polling - Read/Polling)

1. a) Dispatching a write on slot x
- b) Polling the answer onto the write

Indices 2 to 5 are used for accesses to objects from the DPV1 field bus node.

Format of write and read accesses (request and response)

The format for all accesses (request and response, read and write) in DPV1 is:

<DPV1 Header> <Data (PCP/DPV1)>

The DPV1 header here always has the format: <DPV1-Dienst> <Slot> <DPV1-Index> <DPV1-Length>

In the event of an erroneous response the format

- in the event of an E/A module error
 <DPV1-Service> <Slot> <DPV1-Index> <DPV1-Length> <Error-Data (PCP/DPV1)>
- in the event of a DPV1 error
 <DPV1-Service> <Error-Decode> <Error-Code 1> <Error-Code 2>

The <Data (PCP/DPV1)> are optional according to service and are configured as summarized in the following table.

Configuration of the data depending on the service:

Access	Service	Data
Write objects (DPV1 - bus node)	Request	Object data
	Response	None
Read objects (DPV1 - bus node)	Request	None
	Response	Object data
Write objects (E/A module)	Write Request (Write)	Write-PCP / Index High / Index Low / Sub-index / Length PCP-Data / x Bytes Object data
	Write Response (Write)	None
	Read Request (Write)	None
	Read Response (Write)	PCP acknowledgement
Read objects (E/A module)	Write Request (Read)	Read-PCP / Index High / Index Low / Sub-index
	Write Response (Read)	None
	Read Request (Read)	None
	Read Request (Read)	PCP acknowledgement
Write objects with Invoke ID	Write Request (Write)	Invoke-ID / Write-PCP / reserved / reserved / reserved / reserved / Index High / Index Low / reserved / Sub-index / reserved / Length PCP-Data / x Byte PCP-Object data
	Write Response (Write)	None
	Write Request (Write)	None
	Read-Response (Write)	Invoke-ID (mirrored) / Write-PCP / reserved / reserved
Read objects with Invoke ID	Write Request (Read)	
	Write Response (Read)	None
	Read Request (Read)	None
	Read Response (Read)	Invoke-ID (mirrored) / Read-PCP / reserved / reserved / reserved / Length PCP - Data / x Byte PCP - Object data

For all data accesses, a distinction must be made between accesses to modules in the local bus and data on the DPV1 field bus node according to the following table:

Data type	Access to Local bus module	Access to DPV1 bus node	Slot	Index
Module parameter	X		1... 63	2
Control byte (byte 4 of the DPV1 bus node)		X	0	3
Local bus stop acknowledgement		X	0	4
Peripheral fields acknowledgement		X	0	4
Overview of PCP modules and status		X	0	5
PCP data	X		1 ... 63	48
Reserved				47

When accessing the DPV1 field bus node, use the known DPV1 format, carry out write and read accesses in 1 (2) steps. As with PROFIdrive, the data block <Data> is expanded by additional parameters for accesses to the local bus, the sequence now consists of 2 (4) steps.

The parameters have the following relevances:

- <DPV1-Service> in request differentiation between DPV1 read (0x5E) and DPV1 write (0x5F); in response differentiation between 0xDE (Read-Error) and 0xDF (Write-Error)
- <Slot> The slot for the module in the station to be addressed. The DPV1 bus node is addressed with Slot=0, the first E/A module with Slot=1, the second with Slot=2 etc.
- <DPV1-Index> Index 48 should be used for accesses to the communication objects of the local bus Index 2-5 should be used for the other services. Index 47 is reserved for future purposes and should therefore not be occupied (see also table *Objects on the DPV1 field bus node*).
- <DPV1-Length> For write accesses, the length of the subsequent data is indicated here, for read accesses, the length of the expected data. In the event of a response, the actual length of the DPV1 data is found here.
- <Error-Data (PCP/DPV1)> error codes from the PCP access of the local bus
- <Error-Decode> 0x80 identifies errors in DPV1
- <Error-Code 1> and error codes from the DPV1 access



NOTE

When accessing PCP, ensure that the first byte of the PCP data block indicates whether the PCP object should be read or written, PCP Read (=0x01) and PCP Write (=0x02).

Examples

The following examples provide you with a quick introduction. They show how objects can be read and written on the DPV1 field bus node and the E/A modules.

Example 1

Reading the attached local PCP participants and their status (slot 0, index 1 on the DPV1 field bus node)
Read Request (Master → Slave)

Data	Configuration of the data
5E 00 05 20	Read/Slot/Index/max. Length

Read Response (Slave → Master)

Data	Configuration of the data
5E 00 05 03 03 01 00	Read/Slot/Index/Actual length/3 Byte Object data

Example 2

Reading the object 5FFF, sub-index 2 of an IL RS232 on Slot 3
Write Request (Master → Slave)

Data	Configuration of the data
5F 03 30 04 01 5f ff 02	Write/Slot/Index/Length/Read-PCP/Index High/Index Low/Sub-index

Write Response (Slave → Master)

Data	Configuration of the data
5F 03 30 04	Write/Slot/Index/Length

Read Request (Master → Slave)

Data	Configuration of the data
5E 03 30 28	Read/Slot/Index/max. Length

Read Response (Slave → Master)

Data	Configuration of the data
5E 03 30 04 81 00 01 07	Read/Slot/Index/Actual length/4 Byte Object data

From this example you can see how the write / read sequence typical for the PROFIdrive profile delivers the queried value on reading it. In this case, the write-response contains no data. It merely indicates that the write request was received on profibus terminal 8640 DPV1 ME02. The read delivers the data first.

Example 3

Manual acknowledgement of peripheral errors (writing on the DPV1 field bus node, Slot 0, Index 4)

Write Request (Master → Slave)

Data	Configuration of the data
5F 00 04 01 02	Write/Slot/Index/Length/Data

Write Response (Slave → Master)

Data	Configuration of the data
5F 00 04 01	Write/Slot/Index/Length

Here, the data block is only important in the request. The response indicates that the command was received.

Example 4

Writing on object 5FFF, sub-index 0 of an RS232 on Slot 4

Write Request (Master → Slave)

Data	Configuration of the data
5F 03 30 19 02 5F FF 00 14 00 06 02 00 00 24 0D 0A 00 00 00 00 11 13 00 00 00 00 00 00	Write/Slot/Index/Length Data overall/Write-PCP/Index High/Index Low/Sub-index/Length PCP-Data/20 Byte Object data

Write Response (Slave → Master)

Data	Configuration of the data
5F 04 30 19	Write/Slot/Index/Length

Read Request (Master → Slave)

Data	Configuration of the data
5E 04 30 28	Read/Slot/Index/max. Length

Read Response (Slave → Master)

Data	Configuration of the data
5E 04 30 02 82 00	Read/Slot/Index/Actual length/2 Byte Data (PCP acknowledgement)

Example 5

Error: Non-existent object read on an E/A module with PCP functionality (access to 5C00, sub-index 0 on a IL RS232, Slot 3)

Write Request (Master → Slave)

Data	Configuration of the data
5F 03 30 04 01 5C 00 00	Write/Slot/Index/Length/Read-PCP/Index High/Index Low/Sub-index

Write Response (Slave → Master)

Data	Configuration of the data
5F 03 30 04	Write/Slot/Index/Length

Read Request (Master → Slave)

Data	Configuration of the data
5E 03 30 28	Read/Slot/Index/max. Length

Read Response (Slave → Master)

Data	Configuration of the data
5E 03 30 06 81 44 06 07 00 00	Read/Slot/Index/Actual length/6 Byte Object data

You can see that the write response merely indicates that the command has been received, as is customary with PROFIDrive. Processing on the local bus is only launched subsequently. In the process it becomes clear that no processing is possible, since the object does not exist. This is signalled by means of error code 6-7 in the object data. 0x44 is already initiating a basic error.

Since the run on DPV1 ran without problems, the error is not displayed as an error by DPV1, but as an error in the subordinate local bus.

Example 6

Error: Object read on an E/A module without PCP functionality (access to 5FF0, Sub-index 0 to a DO8, Slot 2)

Write Request (Master → Slave)

Data	Configuration of the data
5F 02 30 04 01 5f ff 00	Write/Slot/Index/Length/Read-PCP/Index High/Index Low/Sub-index

Write Response (Slave → Master)

Data	Configuration of the data
5F 02 30 04 01 5f ff 00	Write/Slot/Index/Length/Read-PCP/Index High/Index Low/Sub-index

Read Request (Master → Slave)

Data	Configuration of the data
5E 02 30 28	Read/Slot/Index/max. Length

Read Response (Slave → Master)

Data	Configuration of the data
DE 80 D4 00	Read-Error/ Error-Decode/Error-Code 1/Error-Code 2

In this case write response is already indicating with 0xDF that the service cannot be run. The service cannot be passed on to the E/A module, ensuring that the error code is immediately present. In all error cases, the DPV1 error codes on the one hand (see section *Error during DPV1 communication*), and on the other the general DPV1 error codes (EN50170, PROFIBUS guideline 2.082) are of assistance.

In the example, 0x80 means that error refers to DPV1. D2 00 („module has non PCP“- see section *Error codes during DPV1 communication*) indicates that the module has no PCP. At this point the procedure should already have been cancelled after the write. However, if you try to read the result on Slot 2, you will receive D4 00 („wrong service“ – see section *Error codes during DPV1 communication*). That is, this command is currently not expected, there are no read data available on the slot.

In example 6 you will recognize the other, possible error case:

Function code 0xDE (Error Read), respectively function code 0xDF (Error Write) in connection with error code 0x80. In these cases, errors on the DPV1 level are implied. Use the table in the section *Error codes during DPV1 communication* as a reference with regard to the individual error codes.

PCP via process data (PCP in DPV0)

Communication via process data is a very widespread method for accessing communication objects in E/A modules and on the DPV1 field bus node. The standard for process data traffic is currently the Profibus DP. DPV1 is a protocol expansion which is not yet available on all controls.

With the opportunity to access communication objects acyclically via cyclical process data, the DPV1 field bus node can be used in every environment. Communication objects are therefore also readable from Standard C1 master that merely support the cyclical process data traffic.

Transmission in process data

Transmission in process data takes place via a virtual C1 module (VC1 module). This is a C1 module because it, as is customary with E/A-Module modules, is selected in the hardware configurator and set in the configuration/parameter telegram. This C1 module is only a virtual participant, since the process data are used to transmit communication data (PCP). There are not tied to any specific module. During active process data exchange it is possible to allocate the VC1 module sequentially exchange communication data.

The process data width taken up by the VC1 module in the process data channel, can be chosen from 4 to 16 words in steps of 2 words each. You can therefore use the communication objects even when resources are scarce. When enough resources are free, you work with a data width of up to 16 words.

Elements of the VC1 module

Telegram construction for Request

Byte 1	Service
Byte 2	Module number
Byte 3	Index high
Byte 4	Index low
Byte 5	Sub-index
Byte 6 ... n	Data block, if required

Telegram construction for Response

Byte 1:	Service
Byte 2:	Status
Byte 3 ... m	Data block, if required

Service byte

A central function is held by the service byte. Since several transmissions may be necessary, depending on the data width of the VC1 module, the service byte differentiates between fragments.

- Start fragment
- Continuation fragment
- Conclusion fragment
- Cancel / Error fragment

- **Start fragment**

- Bit 7 0= Request
1= Response
- Bit 6:5 Identification 00: Start fragment
- Bit 4 0: not fragmented
1: fragmented
- Bit 3:0 service 0: no action
1: Read_PCP
2: Write_PCP
3: Read
4: Write
5: Read PDU length (data width of the VC1 channel)

- **Continuation fragment**

- Bit 7 0 = Request
1 = Response
- Bit 6:5 Identification 01: Continuation fragment
- Bit 4:0 Count 1 – 0x1F continuation number; after 0x1F comes 0

- **Conclusion fragment**

- Bit 7 0 = Request
1 = Response
- Bit 6:5 Identification 10: Last fragment
- Bit 4:0 reserve

- **Cancel / Error fragment** (concerning error display)

- Bit 7 0 = Request
1 = Response
- Bit 6:5 Identification 11: Cancel / Error fragment
- Bit 4:0 number of valid bytes follow

Data block

The construction of the data block corresponds to that during DPV1 accesses.

- Byte 1: Number of data bytes
- Byte 2 up to number of data bytes +1: Data

- **Start fragment**

- Byte 1: Service
- Byte 2: Module number
- Byte 3: Index high
- Byte 4: Index low
- Byte 5: Sub-index
- Byte 6: Length
- Byte 7: Data block, if required
- ...
- Byte n: Data block, if required

Byte 1 - *Service in the start fragment:*

Bit 7	Request/Response
	0=Request
	1=Response
Bit 6:5	fragment type
	00= Start fragment
Bit 4	fragmentation
	0= not fragmented
	1= fragmented
Bit 3:0	Service
Hex Value:	0x00: no action
	0x01: Read-PCP
	0x02: Write-PCP
	0x03: Read
	0x04: Write
	0x05: Read PDU length
	0x06-0x0F: Reserved

- **Continuation fragment**

Byte 1: Service

Byte 2: Data block, if required

...

Byte n: Data block, if required

Byte 1 - *Service in the continuation fragment:*

Bit 7	Request/Response
	0 = Request
	1 = Response
Bit 6:5	fragment type
	01= continuation fragment
Bit 4:0	counter
	=1–0x1F Fragment number;
	if more fragments are required, 0 can be continued with after 1F

- **Conclusion fragment**

Byte 1: Service

Byte 2: Data block, if required

...

Byte n: Data block, if required

Byte 1 - *Service in the conclusion fragment:*

Bit 7	Request/Response
	0 = Request
	1 = Response
Bit 6:5	fragment type
	10= Last fragment
Bit 4:0	reserved

- **Cancel / Error fragment**

Byte 1 - Service in the Cancel / Error fragment:

- Bit 7 Request/Response
 - 0 = Request
 - 1 = Response
- Bit 6:5 fragment type
 - 11= Cancel / Error fragment
- Bit 4:0 Reserved

When a service has been completed, acknowledge with the service 00 (clear). The other bytes in the VC1 are then „don't cares“. The DPV1 thus receives the signal that the result has been received by the master. The VC1 module can then receive the next service.

Examples

The same examples as for the DPV1 services are used, in order to clarify the correlations.

Example 1

Reading the attached local PCP participants and their status (slot 0, index 1 on the DPV1 field bus node)

Read Request (Master → Slave)

Data (4 words VC1)	Configuration of the data
03 00 00 05 00 00 00 00	Read /Slot / Index high / Index low / Sub-index 3 Byte unused

Read Response (Slave → Master)

Data (4 words VC1)	Configuration of the data
83 00 03 03 01 00 00 00	Read-Response / Status / Actual length / 3 Byte Object data 2 Byte unused

Clear Request (Master → Slave)

Data (4 words VC1)	Configuration of the data
00 xx xx xx xx xx xx xx	Clear

Clear Response (Slave → Master)

Data (4 words VC1)	Configuration of the data
00 00 00 00 00 00 00 00	Clear Response

Example 2

Reading the object 5FFF, sub-index 2 of a IL RS232 on slot 3

Read Request (Master → Slave)

Data (4 words VC1)	Configuration of the data
01 03 5F FF 02 00 00 00	Read-PCP / Slot / Index high / Index low / Sub-index 3 Byte unused

Read Response (Slave → Master)

Data (4 words VC1)	Configuration of the data
81 00 01 07 00 00 00 00	Read-Response / Status / Actual length / 1 Byte Object data 4 Byte unused

Clear Request (Master → Slave)

Data (4 words VC1)	Configuration of the data
00 xx xx xx xx xx xx xx	Clear

Clear Response (Slave → Master)

Data (4 words VC1)	Configuration of the data
00 00 00 00 00 00 00 00	Clear Response

Example 3

Manual acknowledgement of peripheral errors (writing on the DPV1 field bus node, slot 0, index 4)

Write Request (Master → Slave)

Data (4 words VC1)	Configuration of the data
04 00 00 04 00 01 02 00	Write / Slot / Index high / Index low / Sub-index / Length / Value 1 Byte unused

Write Response (Slave → Master)

Data (4 words VC1)	Configuration of the data
84 00 00 00 00 00 00 00	Write-Response / Status 6 Byte unused

Clear Request (Master → Slave)

Data (4 words VC1)	Configuration of the data
00 xx xx xx xx xx xx xx	Clear

Clear Response (Slave → Master)

Data (4 words VC1)	Configuration of the data
00 00 00 00 00 00 00 00	Clear Response

Example 4

Writing (fragmented) on object 5FFF, Sub-index 0 of an RS232 on slot 4

Write Request (Master → Slave)

Data (4 words VC1)	Configuration of the data
12 04 5F FF 00 14 00 06	Write-PCP / Slot / Index high / Index low / Sub-index / Length / 2 Byte Data

Write Response (Slave → Master)

Data (4 words VC1)	Configuration of the data
12 00 00 00 00 00 00 00	Write-Response / Status 6 Byte unused

MAN 1000010120 EN Version: K Status: RL (released | freigegeben) printed: 23.04.2025

Write Request (Master → Slave)

Data (4 words VC1)	Configuration of the data
21 02 00 00 24 0D 0A 00	Write / 7 Byte Data

Write Response (Slave → Master)

Data (4 words VC1)	Configuration of the data
21 00 00 00 00 00 00 00	Write-Response / Status 6 Byte unused

Write Request (Master → Slave)

Data (4 words VC1)	Configuration of the data
22 00 00 00 11 13 00 00	Write / 7 Byte Data

Write Response (Slave → Master)

Data (4 words VC1)	Configuration of the data
22 00 00 00 00 00 00 00	Write-Response / Status 6 Byte unused

Write Request (Master → Slave)

Data (4 words VC1)	Configuration of the data
40 00 00 00 00 00 00 00	Write / 4 Byte Daten 3 Byte unused

Write Response (Slave → Master)

Data (4 words VC1)	Configuration of the data
82 00 00 00 00 00 00 00	Write-Response / Status 6 Byte unused

Clear Request (Master → Slave)

Data (4 words VC1)	Configuration of the data
00 xx xx xx xx xx xx xx	Clear

Clear Response (Slave → Master)

Data (4 words VC1)	Configuration of the data
00 00 00 00 00 00 00 00	Clear Response

Here, the write response with service 0x82 is the acknowledgement of the write request with 0x12 in the start fragment.

Example 5

Error: Non-existent object read on an E/A module with PCP functionality (access to 5C00, sub-index 0 on a IL RS232, slot 3)

Read Request (Master → Slave)

Data (4 words VC1)	Configuration of the data
01 03 5C 00 00 00 00 00	Read-PCP / Slot / Index high / Index low / Sub-index 3 Byte unused

Read Response (Slave → Master)

Data (4 words VC1)	Configuration of the data
81 44 06 07 00 00 00 00	Read-Response / 5 Byte Error Code 4 Byte unused

Clear Request (Master → Slave)

Data	Configuration of the data
5E 03 30 28	Read/Slot/Index/max. Length

Clear Response (Slave → Master)

Data (4 words VC1)	Configuration of the data
00 00 00 00 00 00 00 00	Clear Response

An error is signalled in the read response of the start fragment with 0x44. 06 and 07 in this case are the error codes which, in accordance with PCP description, show that the addressed index does not exist.

Example 6

Error: Non-existent object read on an E/A module without PCP functionality (access to 5FF0, sub-index 0 to a DO8, slot 2)

Read Request (Master → Slave)

Data (4 words VC1)	Configuration of the data
01 02 5F F0 00 00 00 00	Read-PCP / Slot / Index high / Index low / Sub-index 3 Byte unused

Read Response (Slave → Master)

Data (4 words VC1)	Configuration of the data
81 D2 00 00 00 00 00 00	Read-Response / 2 Byte Error Code 5 Byte unused

Clear Request (Master → Slave)

Data (4 words VC1)	Configuration of the data
00 xx xx xx xx xx xx xx	Clear

Clear Response (Slave → Master)

Data (4 words VC1)	Configuration of the data
00 00 00 00 00 00 00 00	Clear Response

An error is displayed in the read response via 0xD2. Basically, it can be said that an error has occurred if the MSB is set in the second byte or 0x44 appears in the second byte (see also example 5).

Example 7

Fragmented read on IL RS232, slot 3, object 5FFF, sub-index 0 (additional example)

Read Request (Master → Slave)

Data (4 words VC1)	Configuration of the data
01 03 5F FF 00 00 00 00	Read-PCP / Slot / Index high / Index low / Sub-index 3 Byte unused

Read Response (Slave → Master)

Data (4 words VC1)	Configuration of the data
91 00 14 00 07 02 00 00	Read-Response / Status / Actual length / 5 Byte Object data

MAN 1000010120 EN Version: K Status: RL (released | freigegeben) printed: 23.04.2025

Read Request (Master → Slave)

Data (4 words VC1)	Configuration of the data
91 xx xx xx xx xx xx xx	Read / 7 Byte unused

Read Response (Slave → Master)

Data (4 words VC1)	Configuration of the data
A1 24 0D 0A 00 00 00 00	Read-Response / 7 Byte Object data

Read Request (Master → Slave)

Data (4 words VC1)	Configuration of the data
A1 xx xx xx xx xx xx xx	Read / 7 Byte unused

Read Response (Slave → Master)

Data (4 words VC1)	Configuration of the data
A2 11 13 00 00 00 00 00	Read-Response / 7 Byte Object data

Read Request (Master → Slave)

Data (4 words VC1)	Configuration of the data
A2 xx xx xx xx xx xx xx	Read / 7 Byte unused

Read Response (Slave → Master)

Data (4 words VC1)	Configuration of the data
C0 00 00 00 00 00 00 00	Read-Response / 7 Byte Object data

Read Request (Master → Slave)

Data (4 words VC1)	Configuration of the data
C0 xx xx xx xx xx xx xx	Read / 7 Byte unused

Clear Request (Master → Slave)

Data (4 words VC1)	Configuration of the data
00 xx xx xx xx xx xx xx	Clear

Clear Response (Slave → Master)

Data (4 words VC1)	Configuration of the data
00 00 00 00 00 00 00 00	Clear Response



NOTE

Acknowledge every service after completion (including after a cancellation in the event of an error) with 0 (on byte 0).

On Read the master indicates to the slave via the acknowledgement that the master has received the last data package and the slave can send the next data package.

On Write the slave indicates to the master via the acknowledgement that the slave has received the last data package and the master can send the next data package.

Parameterization

In this case, parameterization is the setting of options on an E/A module as well as the pre-setting of failsafe values. In the case of an analogue input module, for example, the measuring range setting is: 0 ... 20 mA or 4 ... 20 mA. In the case of an analogue output module, a security value of x V or Hold can be set. The DPV1 field bus module offers further settings opportunities, in addition to the ability to parametrize E/A modules.

Parameterization possibilities and limits

The parameterization of E/A modules is extremely comprehensive. It ranges from the setting of the measuring range and filter depths on analogue inputs, through the selection of temperature sensors to security values on digital and analogue outputs.

Modules, such as counter and absolute value sensor terminals, provide a variety of settings possibilities which can be adapted highly individually to the application. To this end, parameterization from the application via function blocks is provided for.

Typical parameterization is effected via the C1 on start-up of the slave. Alternatively, parameterization is also possible via acyclical services. This procedure can be of interest, for example, in operation when pre-setting new safety values.



NOTE || Only undertake parameterization via parameter telegram during start-up.

General format of the parameter telegram

Byte 1 ... 7	Norm DP
Byte 8 ... 10	Norm DPV1
Byte 11	DPV1 field bus node parameter byte

E/A module

Byte 1	Parameter byte Security value / Configuration value / PCP
From Byte 2	Configuration block
	Security value
	PCP

Generally it is sufficient to import the GSD and update the device directory. Most HW configuration tools provide a dialouge when a parametrizable module is selected, allowing you to select all adjustable parameters easily. The parameter telegram is composed in the background.

MAN 1000010120 EN Version: K Status: RL (released | freigegeben) printed: 23.04.2025

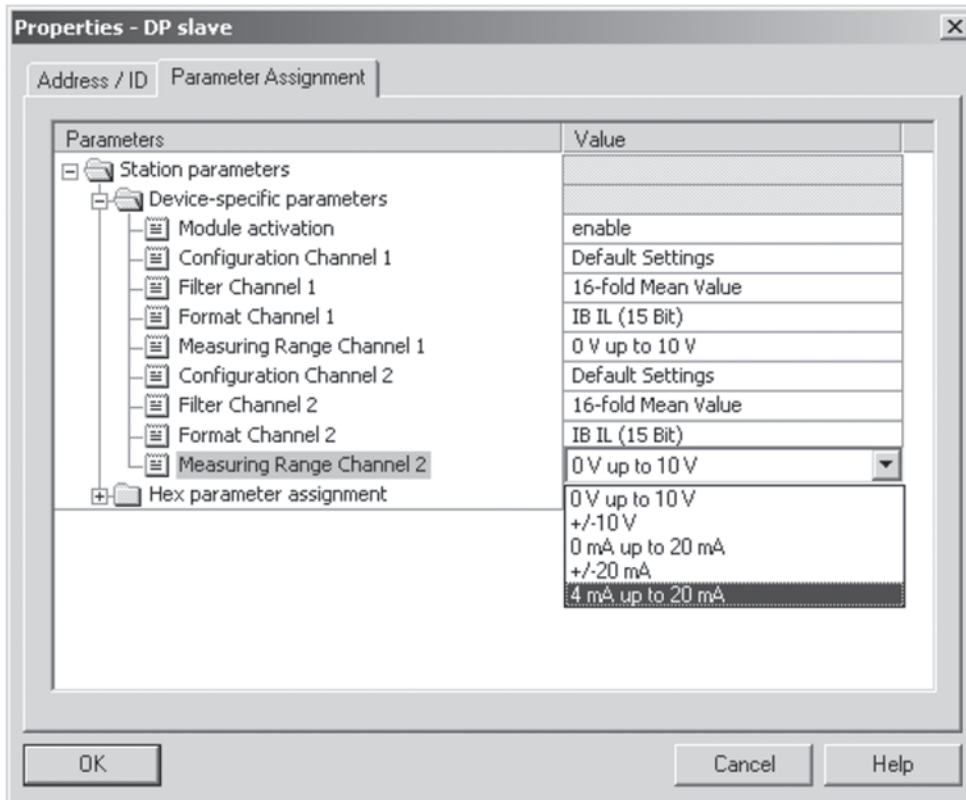

Illustration: Selection as dialogue on AI2/SF

With some tools it is also possible to indicate the hex coding of the parameters directly. In this case you can work with the detailed description of the parameter telegram as well as the GSD file.

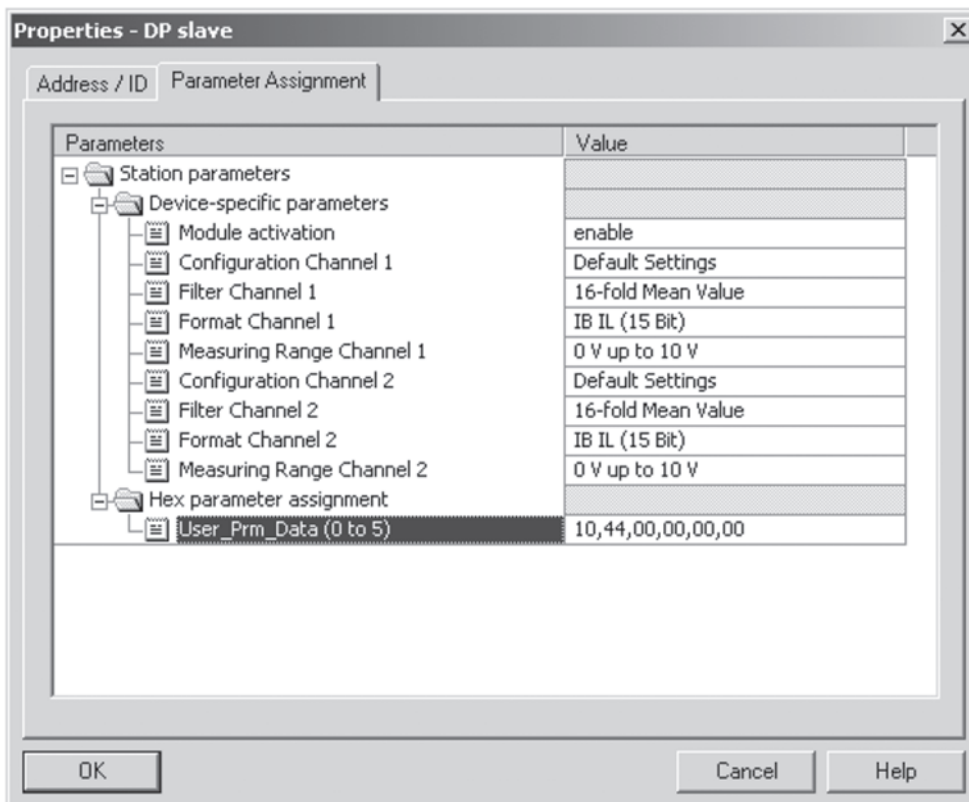

Illustration: Selection in hex format on AI2/SF

The DPV1 field bus node also provides the opportunity to set a number of parameters:

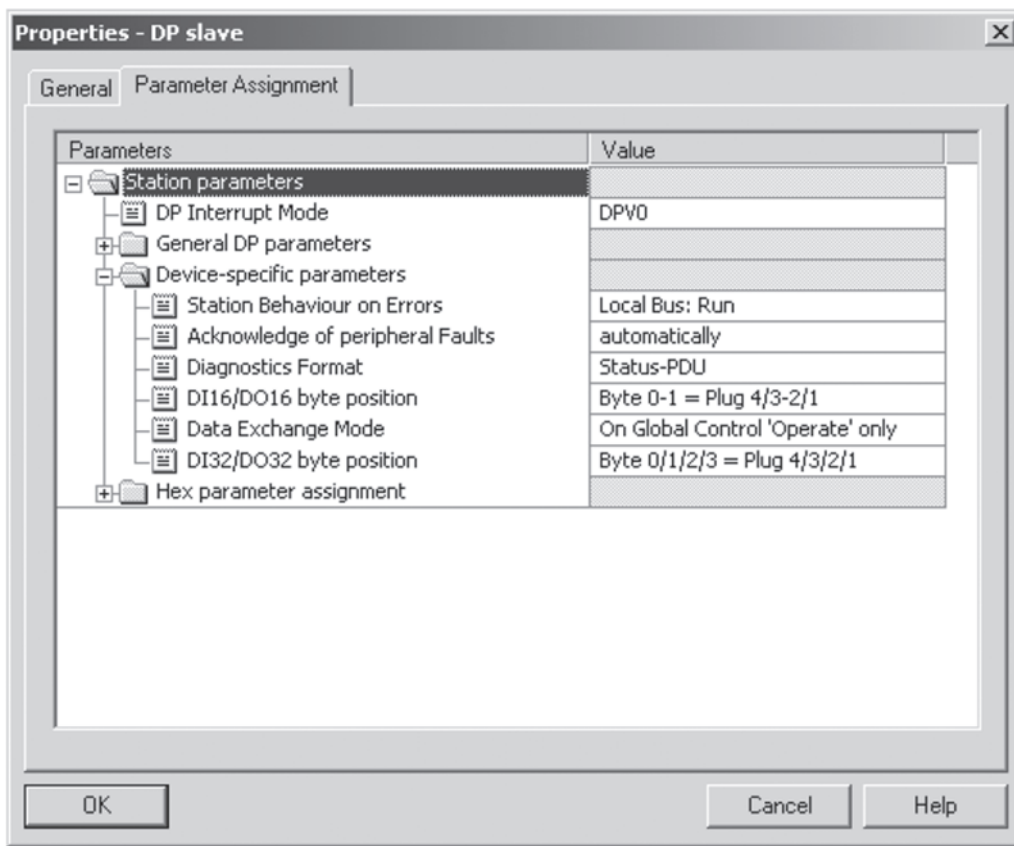

Illustration: Parameters on the DPV1 field bus node

Failsafe values

Failsafe values are output values which become valid as output data in the event of disrupted communication (watchdog comes into effect) or of a PLC stop. Depending on the application, different values may be appropriate: You have a choice between:

- holding the last value
- issuing a zero
- adopting value from the data field

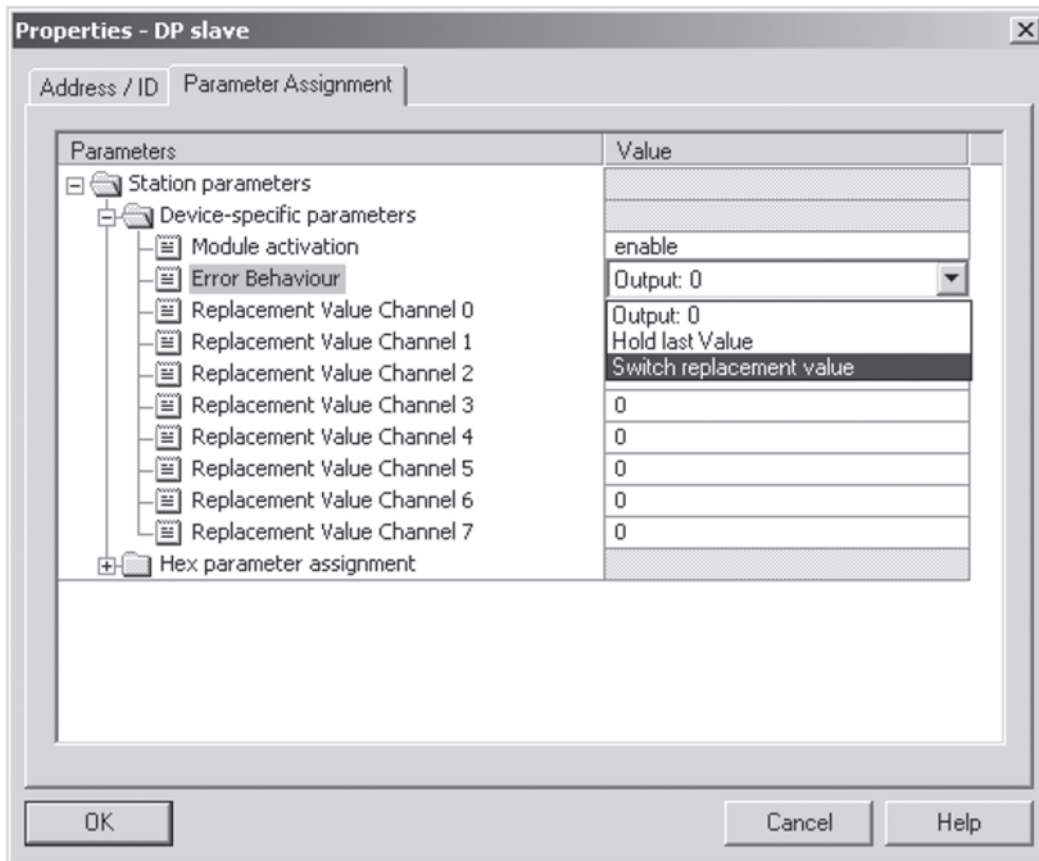

Illustration: Setting the output behaviour of a module

If you choose "Adopt value from data field", the freely selectable substitute values is adopted within the data range, for digital output you have a choice between 0 and 1. For an analogue module between FIXME: -32512 and 32512 (bipolar) or 0 and 32512 (unipolar). These values are converted into a current or voltage value according to the module and the data range being used.

MAN 1000010120 EN Version: K Status: RL (released | freigegeben) printed: 23.04.2025

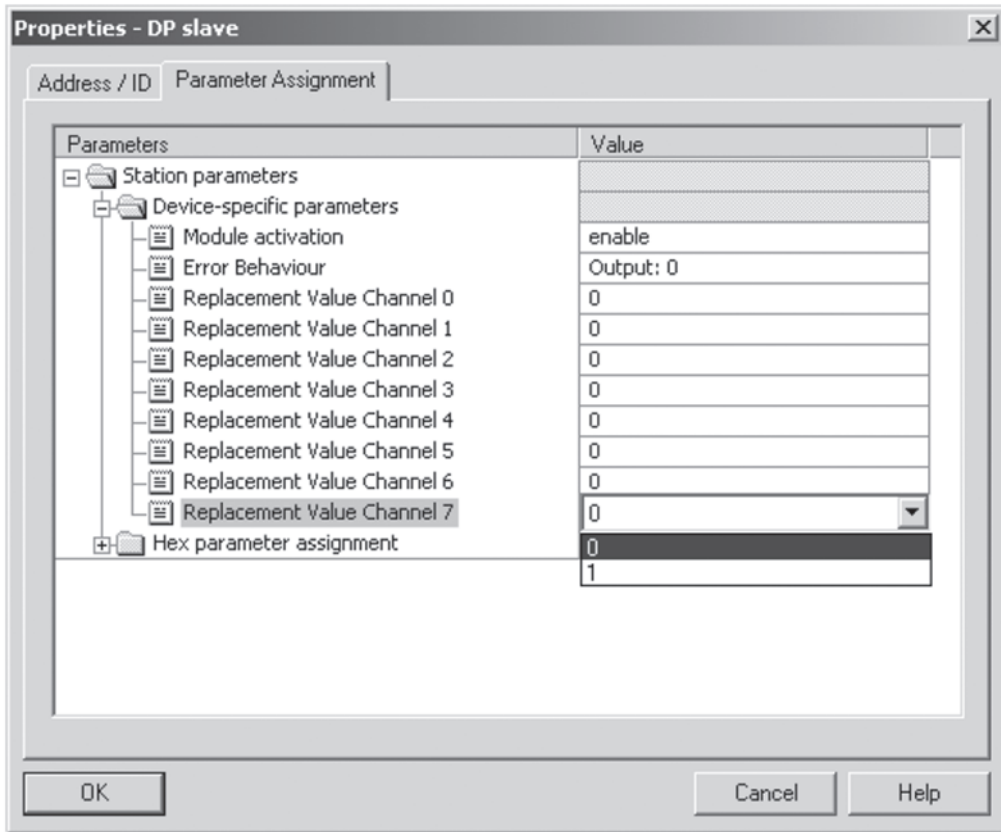

Illustration: of substitute values for an 8-channel, digital output module

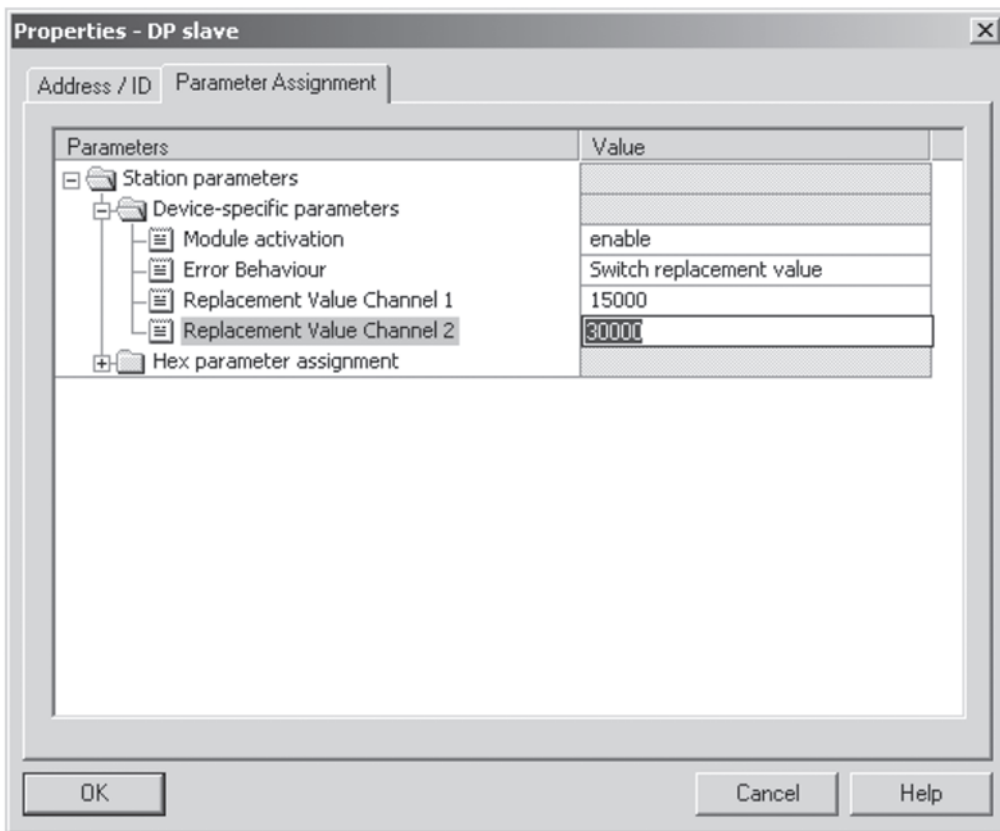

Illustration: Selection of substitute values for a 2-channel, analogue output module



ATTENTION!

The description of the module format in the GSD is not restricted by expanding security and parameter values. I.e. independent parameters are added to the previous configuration data.

Entry into effect of the failsafe values

Failsafe values become valid

- there is no connection to the PLC (watchdog).
One example of this is a severed or unattached cable. If the watchdog period has lapsed without any telegrams being received, then the substitute values is issued when the watchdog is activated.
- the control is on Stop.
No process data are being exchanged. As soon as the control indicates that it is on stop, the substitute values is used. Various controls show their status at intervals via a broadcast.
- no process data circulation takes place following a power-up, yet the parameter telegram has already been received.

There is the possibility that the PLC is already on RUN, but the participant is only now being switched on. In this event the station receives a parameter and configuration telegram. However, it is not guaranteed that the status of the control (RUN/STOP) is already know or that valid data telegrams will follow directly. Therefore, the security values which have already been transmitted in the parameter telegram are issued.

Depending on the parameter and working environment it cannot be guaranteed that the configuration telegram will be transmitted immediately after the parameter telegram. Therefore make sure that the planned configuration is identical to the attached configuration. You thus ensure that the security values from the parameter telegram can be issued safely with the aid of the configuration even before verification.

When the security values are being transmitted, the BF LED flashes. This shows that the output data are under the control of the local slave.

Watchdog

The watchdog checks the receipt of telegrams within a pre-set, maximum time. If no valid telegram is received during this time, the security settings on the slave become active. These concern the output modules in particular. A failsafe value is issued as a substitute value.

This also means that communication with the master has ceased (e.g. cable disruption). When the communication between master and slave has been restored, the slave must start up normally (with parameterization and configuration telegram). This ensures the re-alignment of the local configuration and the configuration deposited on the PLC.

There are the options to activate/de-activate the watchdog and, when the watchdog is activated, to parameterise the time. In doing so the values can be set between 0 (no monitoring) and 650 s in steps of at least 10 ms. A series of configuration tools takes over the setting for the user, since selecting the monitoring time can also become more complex (e. g. due to cycle times that depend on the network as whole).

In STEP7 the watchdog monitoring is activated / de-activated in the HW config. under DP slave properties:

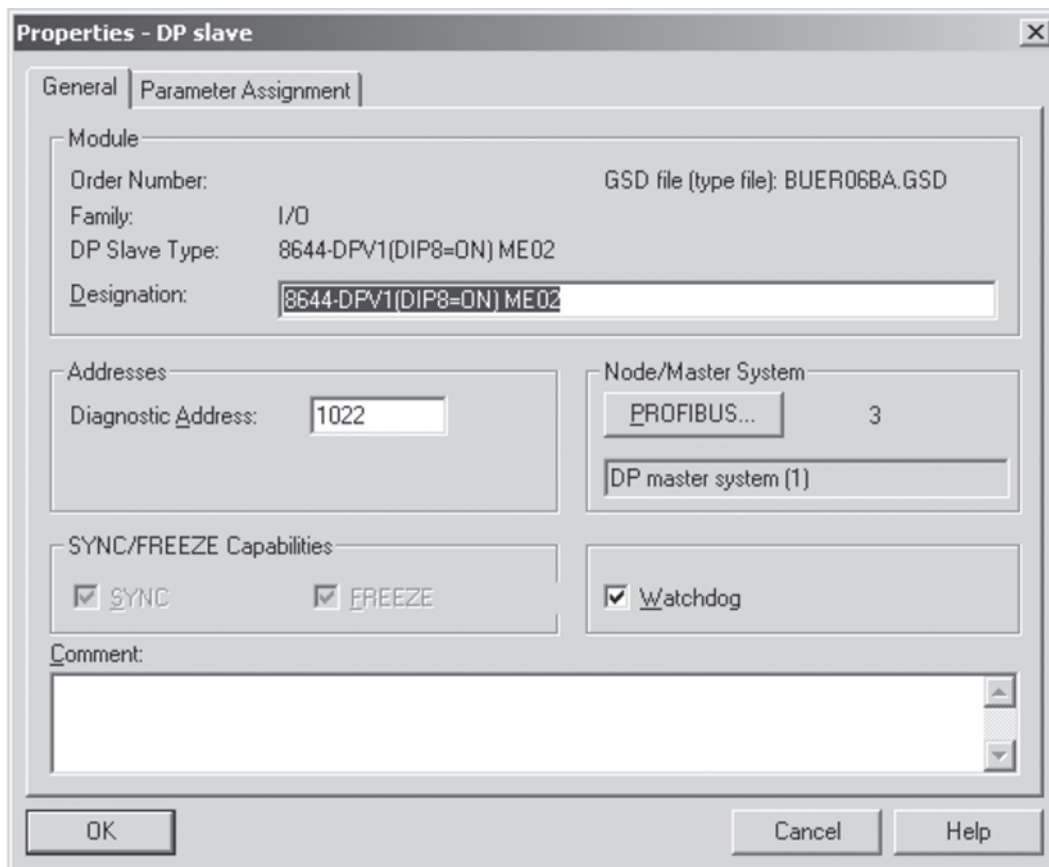

Illustration:
Activating the
watchdog

The duration of the watchdog is set as follows:

Network settings / DP master system properties / Properties / Network settings / bus parameters

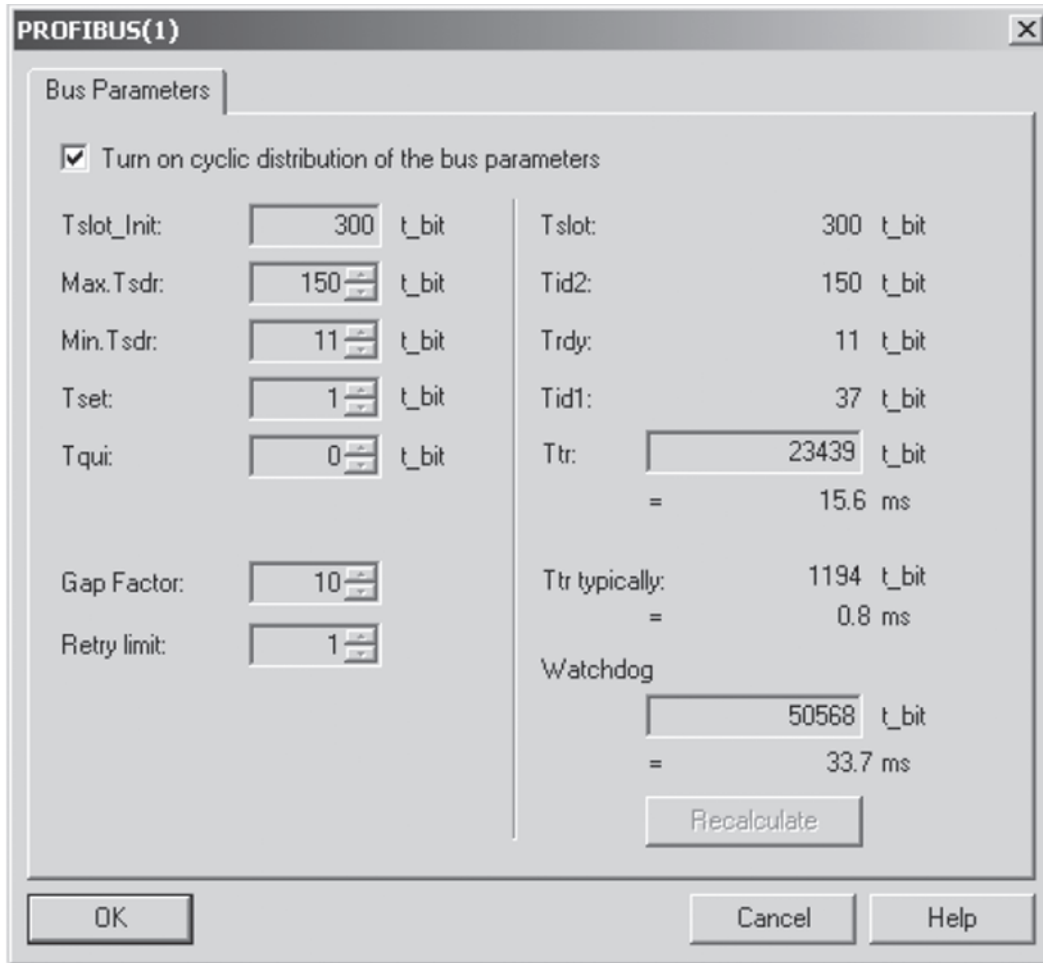

Illustration: Setting the watchdog time

In this case you establish the watchdog time for all participants in the network. Basically, however, this setting is transmitted in the parameter telegram individually for each participant, making it possible to set the watchdog time individually with other configuration tools.

Acknowledgement of peripheral errors

Peripheral errors are errors that are triggered by their own E/A modules under particular error circumstances. They can be acknowledgement-binding or non-acknowledgement-binding errors.

A non-acknowledgement-binding error can be, for example, the short circuit of an output at an IB IL 24 DO16. Non-acknowledgement-binding errors are revoked automatically when the cause of the error has been eliminated.

An acknowledgement-binding error is generated, for example, when the electronic back-up at an IB IL 24 SEG-ELF is triggered. The error must be acknowledged. You can make the acknowledgement on the DPV1 field bus node either automatically or manually. The corresponding setting is effected on parameterization of the DPV1 field bus node:

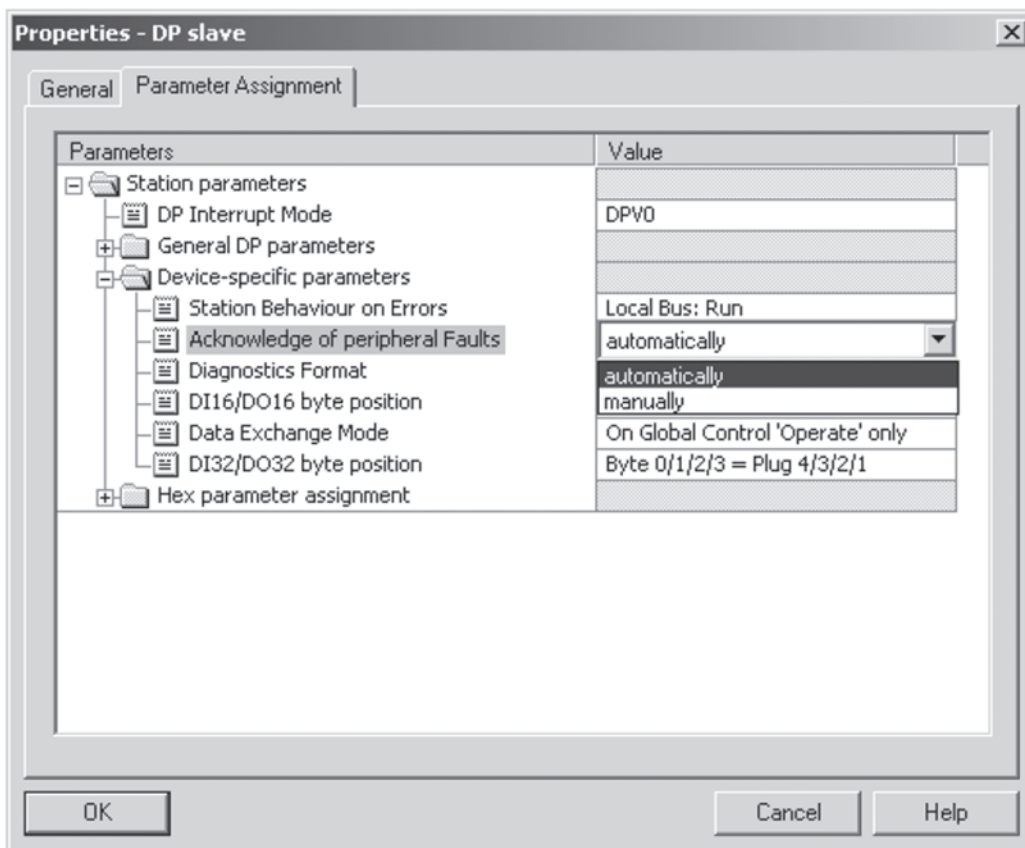

Illustration:
for the acknowledgement
of peripheral
errors

Manual confirmation may be effected via DPV1 (C1 and C2 master) or standard DP. In doing so (Slot 0), Index 0004, sub-index 00 are written onto the DPV1 field bus node.

Acknowledgement: Bit 1 (= 0x02)

Length of data: 1 Byte.

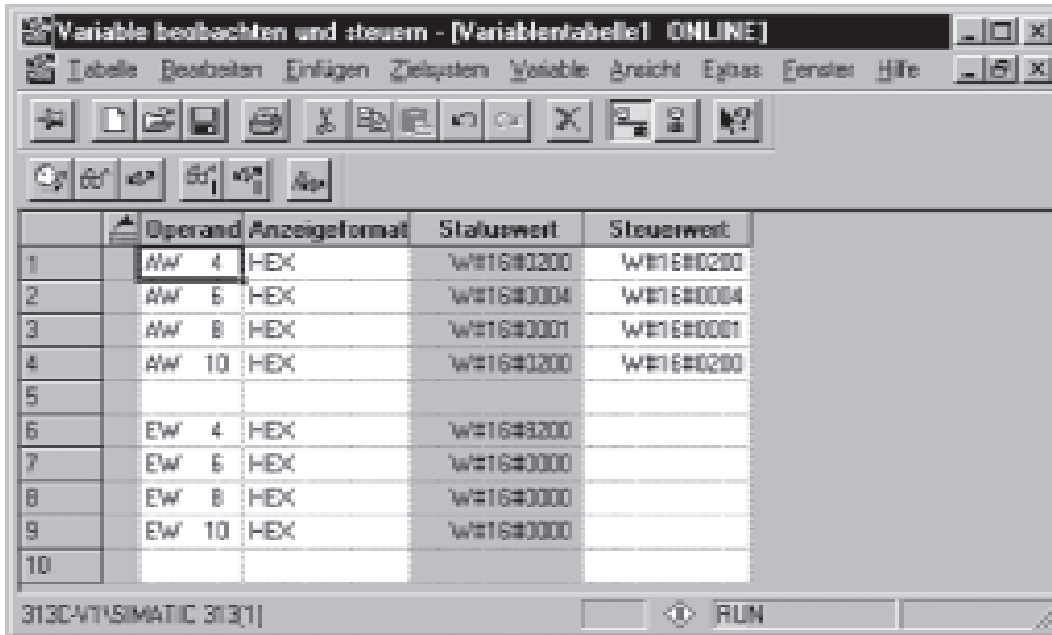

Illustration: Manual acknowledgement of peripheral errors in standard DP (PDP/CP module)

The following telegram (service access points and data content) for an acknowledgement is sent via DPV1 (with C1 and C2 masters):

Master	Source SAP	Dest. SAP	Data content	Comment
C1-Master	51	51	5F 00 04 01 02	
C2-Master	50	48	5F 00 04 01 02	Pay attention to Initiate

Behaviour in PLC stop (new)

IN PLC stop in the new mode (DIP switch 8 = ON), cycles are resumed in the local bus.

The parameterised security values are issued on the output modules. The value 0 is transmitted to a non-parameterised module. The BF LED flashes during transmission; this indicates that the output data are defined by the security values.

The local bus remains in operation. DPV1 commands can be transmitted and processed via the C2 master-The station is available for longer.

Diagnosis (new)

The diagnosis format can be set as a parameter on the DPV1 field bus node. You have the choice between display as a status PDU and identification-related diagnosis.

In addition it is possible to choose the diagnosis of the DP version. This way, operations which were performed on the previous diagnosis can be used again.

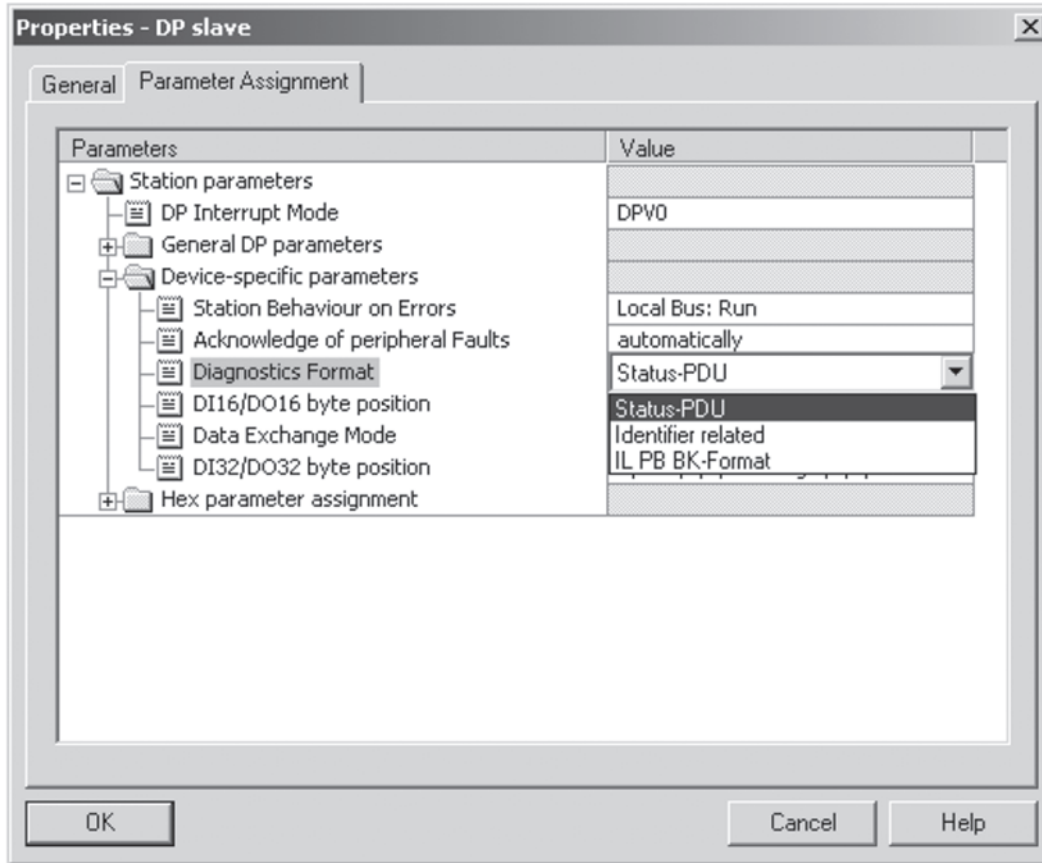

Illustration:
Selecting the
diagnosis
format

Status PDU block

Byte no.	Value	Description
Byte 1	0x09	DPV1 Status PDU header
Byte 2	0x81	DPV1 Status PDU Type Status PDU
Byte 3	Participant number	DPV1 Status PDU slot
Byte 4	0 - 2	DPV1 Status PDU specifier
Byte 5	0 - 5	DPV1 Status PDU User: Error type (see error description)
Byte 6	0 - 12	DPV1 Status PDU User: Error number (see error description)
Byte 7	0 - 255	DPV1 Status PDU User: ID-Code (Interbus)
Byte 8	0 - 255	DPV1 Status PDU User: Length code (Interbus)
Byte 9	0x49	DPV1 Status PDU User: Software version

Specifier

- 0 : no change
- 1 : Error present
- 2 : Error no longer present

Error type

- 0 : no error
- 1 : Profibus – parameter error (Set_Prm)
- 2 : Profibus – configuration error (Chk_Cfg)
- 3 : Configuration error Interbus
- 4 : Interbus error inside the station
- 5 : Module error

Error number

0 to 11 : depends on error type (see *error description section*)

A peripheral error on module 2 (IB IL 24 DO 8) is displayed in status PDU format as follows:

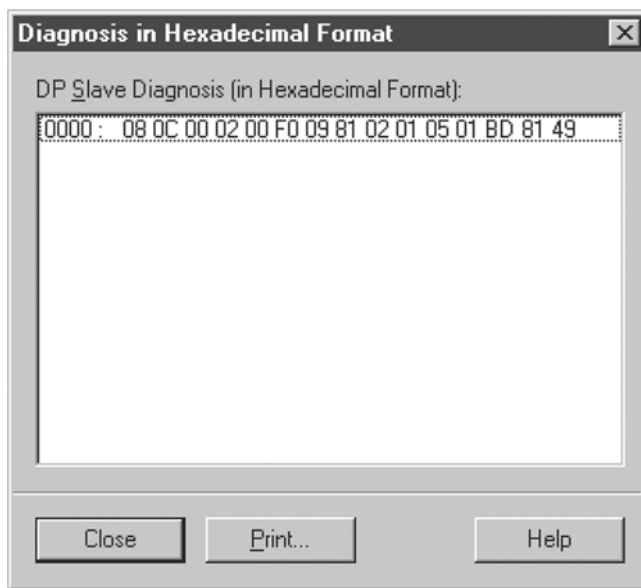

Illustration: Peripheral error on module 2 in status PDU format

ID-related (module) diagnosis

Byte no.	Value	Description
Byte 1	0x49	Header
Byte 2	0-255	Module 1 to 8
Byte 3	0-255	Module 9 to 16
Byte 4	0-255	Module 17 to 24
Byte 5	0-255	Module 25 to 32
Byte 6	0-255	Module 33 to 40
Byte 7	0-255	Module 41 to 48
Byte 8	0-255	Module 49 to 56
Byte 9	0-255	Module 57 to 64

Byte 2 ... 9 : One bit is reserved for each module. If the bit is set, the module is experiencing an error.

- Byte 0 Bit 0 : Module 1
- Byte 0 Bit 1 : Module 2
- :
- Byte 0 Bit 7 : Module 8
- Byte 1 Bit 0 : Module 9
- :

Error report for the ID-related diagnosis format:

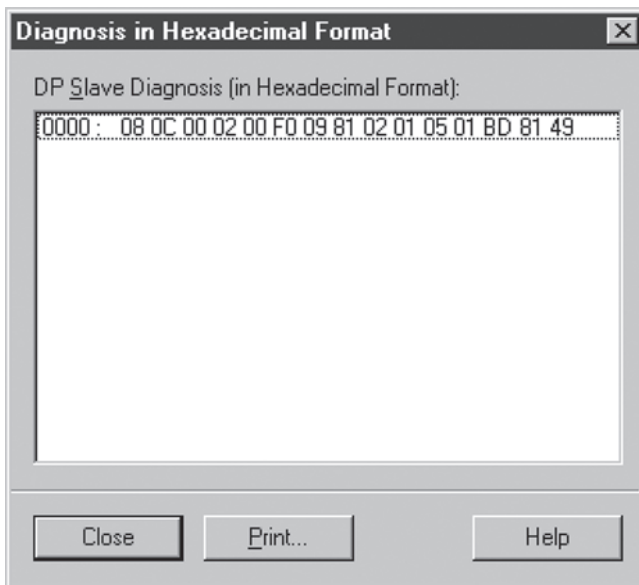

Illustration: Peripheral error on module 2 in ID-related diagnosis format

MAN 1000010120 EN Version: K Status: RL (released | freigegeben) printed: 23.04.2025

With the diagnosis recognised by the DPV1 field bus node up to serial number 37343, the error is displayed as follows:

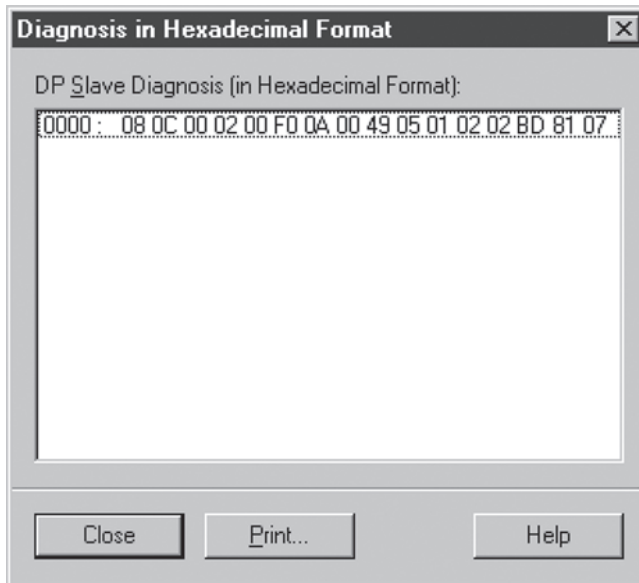

Illustration: Peripheral error on module 2 in manufacturer-specific format recognised by the DPV1 field bus node

Parameter telegram format

This section describes the composition of parameters for DPV1 field bus node and E/A module. If you wish to parameterise via acyclical services, or if there is no interface available for easy parameter selection, you must be familiar with the composition of the parameters.

For the DPV1 field bus node:

Byte 1 - 7	Norm DP
Byte 8 - 10	Norm DPV1
Byte 11	Control byte Bit 0 = 0 no stop in event of error = 1 stop in event of error
	Bit 1 = 0 automatic error acknowledgement = 1 acknowledgement via acyclical channel required
	Bit 3:2 = 00 Status PDU = 01 ID-related (module) diagnosis = 10 old diagnosis
	Bit 4 = 0 do not switch DI16 or DO16 data = 1 switch DI16 or DO16 data
	Bit 5 = 0 DXCH only when Global Control OPERATE = 1 DXCH without Global Control OPERATE
	Bit 7:6 = 0 Reserve

For modules:

Byte 1	Bit 7:6 = 00 ID start block for participants
	Bit 5:4 Configuration = 00 no configuration (e.g. for DO module; the configuration value block is omitted) = 01 configuration permanent (configuration value block is analysed) = 10 configuration briefly (configuration value block is analysed)
	Bit 3:2 security value = 00 no security value (e.g. for DI module; since the security value block is omitted) = 01 zero issued (safety value block is not analysed) = 10 value retained (security value block is not analysed) = 11 adopt value from the data field (security value block is analysed)
	Bit 1:1 PCP = 0 no PCP block = 1 PCP block
	Bit 0:0 reserve

Byte 2	Bit 7:6	= 01 ID for configuration block
	Bit 5:0	Length (bytes) of the data block
Byte 3 to Byte 3 + (n-1)	n	Data bytes

Byte ?*	Bit 7:6	= 10 ID for security value block
	Bit 5:0	Length (bytes) of the data block
Byte ?-?	?	Data bytes

Byte ?	Bit 7:6	= 11 ID for PCP block
	Bit 5:0	Length (bytes) of the data block (incl. Index/sub-index)
Byte ?+1		Index High-Byte
Byte ?+2		Index Low-Byte
Byte ?+3		Sub-index
Byte ?-?	?	Data bytes

* "?" is a placeholder for those bytes which could not be named as a package in the run-up. The bytes are counted consecutively, so therefore the naming is oriented among other things to the number of data bytes and the presence of individual blocks.

Data for configuration, security value and PCP are determined with the aid of the module-specific data sheets.

Parameterise the configuration data (measuring range, sensor type ...) on device start-up.

You can only re-parameterise via acyclical services in the data exchange mode.

Switching round bytes in IB IL24 DI16 / IB IL24 DO16 terminals

In order to adapt the 16-channel digital modules to the data format of the control there is the opportunity to switch the byte position for channel 1-8 and 9-16. By default, channels 9-16 (slot 3.x and 4.x) are on byte n and channels 1-8 (slot 1.x and 2.x) are on byte n+1.

The format is switched with bit 4 in the control byte (parameter telegram, byte 11, see *Parameter telegram section*). Channels 1-8 (slot 1.x and 2.x) are then on byte n and channels 9-16 (slot 3.x and 4.x) on byte n+1.

Default (Bit 4=0)

Byte	0								1							
Bit	7	6	5	4	3	2	1	0	7	6	5	4	3	2	1	0
Slot	4				3				2				1			
Terminal point	2.4	1.4	2.1	1.1	2.4	1.4	2.1	1.1	2.4	1.4	2.1	1.1	2.4	1.4	2.1	1.1

Switched (Bit 4=1)

Byte	1								0							
Bit	7	6	5	4	3	2	1	0	7	6	5	4	3	2	1	0
Slot	4				3				2				1			
Terminal point	2.4	1.4	2.1	1.1	2.4	1.4	2.1	1.1	2.4	1.4	2.1	1.1	2.4	1.4	2.1	1.1

Switching round bytes on IB IL24 DI32 / IB IL24 DO32 terminals

In order to adapt the 32-channel digital modules to the data format of the control there are opportunities to switch the byte position of channel groups 1-8, 9-16, 17-24 and 25-32. By default, channel 1-8 (slot 1.x) are on byte n+3 and channels 9-16 (slot 2.x) on byte n+2, channels 17-24 (slot 3.x) on byte n+1 and channels 25-32 (slot 4.x) on byte n.

If bit 6 is set in the control byte (parameter telegram, byte 11, see *Parameter telegram section*), switch the format. Channels 1-8 (slot 1.x) are then on byte n and channels 9-16 (slot 2.x) on byte n+1, channels 17-24 (slot 3.x) on byte n+2 and channels 25-32 (plug 4.x) on byte n+3.

Default (Bit 6=0)

Byte	0					1					2					3				
Bit	7	6	...	1	0	7	6	...	1	0	7	6	...	1	0	7	6	...	1	0
Slot	4					3					2					1				
Terminal point	8.4	7.4	...	8.-1	7.1	6.4	5.4	...	6.1	5.1	4.4	3.4	...	4.1	3.1	2.4	1.4	...	2.1	1.1

Switched (Bit 6=1)

Byte	0					1					2					3				
Bit	7	6	...	1	0	7	6	...	1	0	7	6	...	1	0	7	6	...	1	0
Slot	1					2					3					4				
Terminal point	2.4	1.4	...	2.1	1.1	4.4	3.4	...	4.1	3.1	6.4	5.4	...	6.1	5.1	8.4	7.4	...	8.1	7.1

Data Exchange and Global Command Operate

In the profibus, broadcast messages indicate the status of the PLC.

CPU313C-2 DP for example is a CPU that displays its status to other participants in the network via broadcasts of this type. The DPV1 field bus node decides on the basis of these reports whether process data values or security values should be issued.

The DPV1 field bus node initially starts with the security values after the parameter telegram has been received. If it receives a broadcast, the security values are either retained or converted to process data operation, according to the status of the PLC.

If no broadcast is sent, the option of *data exchange without broadcast operate* is relevant. The option not to have the device wait for the broadcast from the control can be set in the parameter telegram. In this event, the process data exchange is recorded following parameterization and configuration on receipt of the first data telegram.

Control stop example:

The control stop is displayed via a broadcast from the CPU313C-2 DP. The security values are cut in immediately. If the PLC does not display the control stop or if the data exchange without *broadcast operate option* is not activated, the security values are triggered when the watchdog time lapses. The previous process data remain valid until that point.

Analysis of the broadcast is adjustable for the DPV1 field bus node in bit 5 of the control byte (parameter telegram, byte 11, see *Parameter telegram* section).

DPV1 field bus node object directory

The following objects are available on the DPV1 field bus node:

Slot	Index	Service	Comment
1 ... 63	2	Write	Module parameter
0	3	Write	Control byte (diagnosis format, manual peripheral error acknowledgement ...)
0	4	Write	Acknowledgement (local bus event) 1: Local bus stop acknowledgement 2: Peripheral fields acknowledgement
0	5	Read	Overview of PCP modules and status
1 ... 63	47	Read/Write	PCP data to profile profidrive
1 ... 63	48	Read/Write	PCP data

Index 2: Module parameter

According to the format of the parameter telegram (see *Parameter telegram* section) you can pre-set security and configuration values via slots 1-63 for every E/A module. The DPV1 field bus node monitors the connection to the master. This makes index 2 a parameter deposited on the DPV1 field bus node with reference to E/A modules.

Index 3: Control byte

The parameter telegram provides a user-specific byte for the DPV1 field bus node with which, for example, the diagnosis format can be selected. However, in addition to transmission in the parameter telegram (byte 11, see *Parameter telegram* section), it is also possible to pre-set the byte under index 3. This means that you can re-parameterise during operation.

- Bit 0 = 0 no stop in event of error (local bus)
= 1 stop in event of error (local bus)
- Bit 1 = 0 automatic error acknowledgement (e.g. in event of peripheral errors)
= 1 manual acknowledgement necessary
- Bit 3:2 = 00 Status PDU format
= 01 ID-related diagnosis
= 10 manufacturer-specific diagnosis (DPV1-FELDBUSKNOTEN)
- Bit 4 = 0 DI16 and DO16 Format Byte 0 / Byte 1
= 1 DI16 and DO16 Format Byte 1 / Byte 0
- Bit 5 = 0 Data exchange with Broadcast Operate
= 1 Data exchange without Broadcast Operate
- Bit 7:6 reserved

Index 4: Acknowledgement (local bus event)

With index 3 (bit 0 and 1) it is possible to adjust the different behaviour in the local bus. By default, the occurring peripheral errors are acknowledged automatically and the local bus, if possible, kept permanently on Run.

However, depending on the application it may be asked that an automatic acknowledgement is not permitted and particular measures must be taken. You can then react manually to bus events via index 4. This applies for a module error in the form of an acknowledgement-binding peripheral error, but also after the elimination of a serious error where data communication was no longer possible.

Bit 0	Acknowledgement, local bus stop
Bit 1	Acknowledgement, peripheral error
Bit 7:2	reserved

Index 5: Overview of PCP modules and status

3 bytes are read for every PCP module attached:

Byte 1	Position in the station (slot)
Byte 2	PCP connection status
	0x00 PCP connection OK
	0x01 No PCP connection
	0x02 Module has no PCP
	0x03 Timeout from module
	0x04 Request running
Byte 3	PCP service status
	0x00 Idle (no action)
	0x01 Read
	0x02 Write

Index 47: PCP data to PROFIDrive format

Index 47 is a parameter on the DPV1 field bus node via which the connection between master and E/A module can be produced on the basis of the PROFIDrive format during DPV1/PCP communication. This means that the slot number (1-63) is needed. Parameters, such as the axis for example, are not analysed.

Index 48: PCP data

The connection between master and E/A module during DPV1/PCP communication is created via Index 48. The reference to the E/A device is made via the slot number (1-63).

Error codes during DPV1 communication



ATTENTION!

Error codes during DPV1 communication are errors in relation to DPV1/PCP. During DPV1 communication you will find the error code on byte 3, during communication in the process data channel, error code 1 is located on byte 2 of the response. Pay attention to the individual displays in your working environment at all times.

If there is an error present during DPV1 or PD-PCP communication in relation to an E/A module, this is displayed via 0x44 on byte 2 of the data block.

DPV1 error: Function_Num = 0xDE (Error Read) or 0xDF (Error Write)
 Error_Decode = 0x80 (DPV1 communication)

Error codes during DPV1 communication

Error_Code_1	Error_Code_2	Comment
0xA0	0	Object from the field bus module cannot be read.
0xA1	0	Object from the field bus module cannot be written.
0xB0	0	Wrong index from the field bus module.
0xB1	0	The PB-PDU length is too small.
0xB2	0	wrong slot
0xB5	0	Module is busy.
0xB7	0	Error while writing on index 47 or 48.
0xD1	0	No PCP connection.
0xD2	0	Module has no PCP.
0xD3	0	Timeout from module.
0xD4	0	wrong service
0xD5	0	VC1 sequence not correct
0xD6	0	VC1 Length incorrect
0xF..		Error while writing module parameter.
0xF1	0	An incorrect module number was used.
0xF2	0	The parameter block is incomplete.
0xF3	0	The data length of the parameter block is too small.
0xF4	0	The data length of the parameter block is too big.
0xF5	0	The internal block for configuration, security value and PCP is too small.
0xF6	0	Header byte from the module parameter block is not correct.
0xF7	0	PCP initialisation for a module that has no PCP functionality.
0xF8	0	Too many data blocks for the module.

Error codes during PCP communication

State conflict	
Coding	05h / 01h
Relevance	A start or stop command was sent twice.
Cause	Error only occurs during the start or stop service: Since start or stop has already been carried out, the service cannot be carried out again.
Resolution	No action necessary.

Hardware fault	
Coding	06h / 02h
Relevance	Access to the object failed due to a hardware fault.
Cause	e.g. no peripheral voltage
Resolution	Remedy the fault.

Object Access Denied	
Coding	06h / 03h
Relevance	The object has restricted access rights.
Cause	The object may only be able to be read but is not writable, or it is password protected.
Resolution	Check the access rights in the object description.

Object Attribute Inconsistent	
Coding	06h / 05h
Relevance	A service parameter was given with an impermissible value.
Cause	e.g. an incorrect length indication or an impermissible sub-index
Resolution	Check the parameters on the basis of the object description and re-set the service with the corrected values.

Error messages in communication

Object Access Unsupported	
Coding	06h / 06h
Relevance	The service used cannot be applied to this object.
Cause	e.g. a program sequence can be started or stopped, but not read.
Resolution	Check which services are permitted for this object in the object description.

Object Non Existent	
Coding	06h / 07h
Relevance	The object does not exist.
Cause	The "Index" parameter probably has an incorrect value.
Resolution	Check the index of the basis of the object description and re-set the service.

Other error messages

Application Error	
Coding	08h / 00h
Relevance	Device-specific error message; no error in communication.
Cause	-
Resolution	Check in your device description.

Firmware-Error	
Coding	09h / XXh
Relevance	You will find the description of this error messages in the general INTERBUS documentation „Firmware services and error messages“. All error codes of error category 09h are listed there in "Error codes concerning user error" under code 09h / xxh.
Cause	-
Resolution	Check in your device description.



NOTE

Specific error codes can be deposited, depending on the E/A terminal. These are listed in the respective data sheet / manual.

Firmware-Error	
Coding	09h / XXh
Relevance	You will find the description of this error messages in the general INTERBUS documentation „Firmware services and error messages“. All error codes of error category 09h are listed there in "Error codes concerning user error" under code 09h / xxh.
Cause	-
Resolution	Check in your device description.

Error description

Parameter error on the PROFIBUS (SET_PRM-Telegram)			
Type	No.	Cause of error	Resolution
1	1	An incorrect terminal number is being used.	Check whether the terminal is parameterizable.
	2	A parameter block is incomplete.	The number of terminals and parameter blocks does not match.
	3	The data length of the parameter block is too small.	Check the number of parameters.
	4	The data length of the parameter block is too big.	Check the number of parameters.
	5	The internal block for configuration, security value and PCP is too small.	Check the configuration of the parameters for the terminals.
	6	Header byte of the module parameter is not correct.	Check the first byte of the module parameters.
	7	PCP initialisation of a terminal that has no PCP functionality.	Check the planning.
	8	Too many data blocks for the terminal.	The number of terminals and parameter blocks does not match.
	9	Incomplete data block in a de-activated terminal.	Check the number of parameters.

Parameter error on the PROFIBUS (CHK_CFG-Telegram)			
Type	No.	Cause of error	Resolution
2	1	Fewer AirLine terminals were configured than are present in the station.	Add the terminals in the configuration.
	2	More AirLine terminals were configured than are present in the station.	Delete the superfluous terminals from your configuration or add the missing terminals to the station.
	3	The first byte of the special ID format of the AirLine terminal contains errors.	Ascertain the precise location of the error with the aid of the device-specific diagnosis in your control.
	4	Too few bytes from the special ID format for the last AirLine terminal configured.	Check the ID format.
	5	The sum of configured process data for inputs and outputs on the station is greater than 184 bytes (DIP8=OFF) or 176 bytes (DIP8=ON).	Bring together several AirLine terminals in the configuration so that the process data become compressed (fewer empty bits).
	6	The ID code of the configuration does not match that of the AirLine terminal.	Ascertain the precise location of the error with the aid of the device-specific diagnosis in your control. Check the configuration in the hardware configurator.

Parameter error on the PROFIBUS (CHK_CFG-Telegram)			
Type	No.	Cause of error	Resolution
2	7	The length code of the configured AirLine terminal does not match the length code of the terminal in the station.	Ascertain the precise location of the error with the aid of the device-specific diagnosis in your control. Check the configuration in the hardware configurator.
	8	The number of manufacturer-specific data from the special ID format of the AirLine terminal contains errors. The number is 2, 3 or a multiple of 2.	Ascertain the precise location of the error with the aid of the device-specific diagnosis in your control.
	9	Too few output process data for the AirLine terminal were configured inside the ID format.	Ascertain the precise location of the error with the aid of the device-specific diagnosis in your control.
	10	Too few input process data for the AirLine terminal were configured inside the ID format.	Ascertain the precise location of the error with the aid of the device-specific diagnosis in your control.
	11	More than 244 bytes are required for configuration of the PROFIBUS.	
	12	An internal list is too short.	
	13	Too few output bytes configured for deactivated terminals.	Ascertain the precise location of the error with the aid of the device-specific diagnosis in your control.
	14	Too few input bytes configured for deactivated terminals.	Ascertain the precise location of the error with the aid of the device-specific diagnosis in your control.

Configuration errors in the station			
Type	No.	Cause of error	Resolution
3	1	The AirLine terminal is not cleared for operation in the bus coupler.	Ascertain the precise location of the error with the aid of the device-specific diagnosis in your control. Remove the terminal from the station.
	2	The length code of the AirLine terminal corresponds to a length of 0 byte.	Ascertain the precise location of the error with the aid of the device-specific diagnosis in your control. Inspect the terminal and remove it from your configuration if necessary.
	3	The length code of the AirLine terminal corresponds to a length of more than 32 bytes.	Ascertain the precise location of the error with the aid of the device-specific diagnosis in your control. Remove the terminal from the station.
	4	The station contains a loop 1 module.	Loop 1 modules are not cleared for operation at the bus coupler. Ascertain the precise location of the error with the aid of the device-specific diagnosis in your control. Remove the module from the station and replace it with a loop 2 module.
	5	The sum of process data in the local bus is greater than 250 bytes.	Check the number of process data and reduce the number of terminals in the station.
	6	More than 64 AirLine terminals and loop 2 modules are plugged in.	Check whether more than 64 AirLine terminals and loop 2 modules are present in the station. If yes, reduce the number.
	7	The sum of process data for the inputs and outputs on the PROFIBUS is greater than 176 bytes. (184 bytes in DPV0 mode)	Remove the terminals from the station.
	8	More than eight PCP slaves are plugged in.	Reduce the number of PCP terminals in the station.

Local bus errors in the station			
Type	No.	Cause of error	Resolution
4	1	An error has occurred in the local bus signal (Data In).	Ascertain the precise location of the error locally on the basis of the LEDs or with the aid of the device-specific diagnosis in your control. Check the connection between the displayed participants.
	2	An error has occurred in the local bus signal (Data Out).	Ascertain the precise location of the error locally on the basis of the LEDs or with the aid of the device-specific diagnosis in your control. Check the connection between the displayed participants.
	3	An error in the data transfer between AirLine terminals has occurred. The error could not be located.	Check the configuration of the station.
	4	The AirLine terminal is not ready.	Ascertain the precise location of the error with the aid of the device-specific diagnosis in your control. Check the electrical connection.
	5	The replacement AirLine terminals does not match in length or ID code.	Remove the terminal from the station. Ascertain the precise location of the error with the aid of the device-specific diagnosis in your control.
	6	An additional AirLine terminal has been added.	Check the configuration of the station. If the configuration is correct, switch off the power supply briefly so that the new configuration is adopted.

Terminal errors			
Type	No.	Cause of error	Resolution
5	1	A fault has occurred in your peripheral switching (e.g. short circuit of actuator overload).	On the basis of the PROFIBUS address and the participant number it is possible to ascertain the station and AirLine terminal on which the peripheral fault has occurred. The location of the error can be recognised by the flashing LED on the AirLine terminal or with the aid of the device-specific diagnosis in your control. On the basis of the terminal datasheet, check which fault may trigger this error message. Remedy the fault in your peripherals.
	2	Terminal not ready.	Ascertain the precise location of the error with the aid of the device-specific diagnosis in your control. Check the electrical connection.

MAN 1000010120 EN Version: K Status: RL (released | freigegeben) printed: 23.04.2025

Parameter errors on the local bus		
Type	No.	Cause of error
6	1	General parameter errors (Initiate)

Error during memory access		
Type	No.	Cause of error
7	1	No memory present
	2	Test sum error
	3	Read error
	4	Write error
	5	Initialisation
	6	Stored configuration not identical to actual configuration.

CONNECTOR MODULES

Structure of the connector module

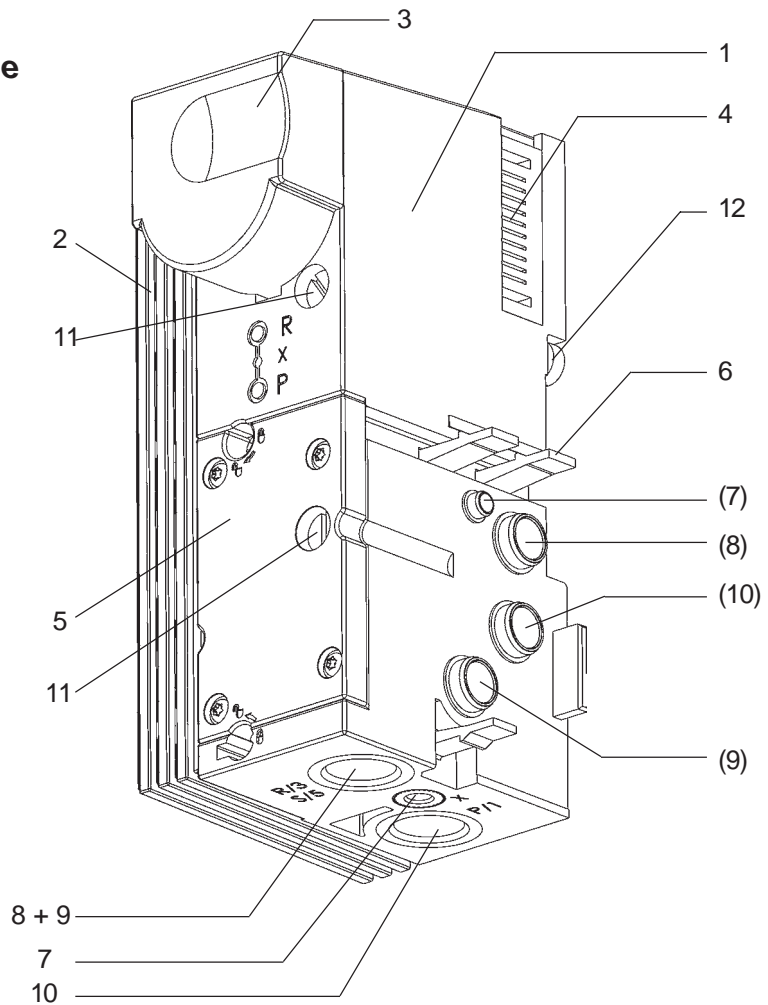

Structure of the connector module

No.	Designation	Description
1	pneumatic supply	Type MP11 / MP12 (left, middle, right)
2	electrical connector module	Type ME02 / ME 03 (left, right) Interface to electrical part of automation system (field bus nodes; electrical modules/terminals)
3	Cover	Version with manometer or electronic pressure measurement module
4	Shunting	(socket left, plug right) Electrical interface to data shunting within the Bürkert AirLINE System Type 8644
5	Cover plate	
6	Interlock hooks	Mechanical fixing for basic pneumatic modules MP11 / MP 12
7	X	Port for pilot exhaust air/auxiliary control air
8	(R) 3	Exhaust air port
9	(S) 5	Exhaust air port
10	(P) 1	Pressure supply port
11	Screws	Fixing screws for rail mounting
12	Clamping pieces	Fixing clamping pieces for rail mounting

Variants

The supply units have been designed in various variants to take account of differing requirements. For simple commissioning and diagnosis, supply units are available with a manometer. You can obtain the fluidic connections with straight or conical screw connections as well as with fast coupling systems. For special functions the fluidic connections may be used for different purposes, e.g. the exhaust air connection may be used for the pilot valve as a connection for the auxiliary control air, whereby different pressures may be applied for supply and for control of the valve.

The supply units differ in e. g.

- Manometer, electronic pressure measurement module

- Connection type

MP11	MP12
G 1/4"	G 3/8"
D10	NPT 3/8"
NPT 1/4"	

- Auxiliary control air yes / no

Connector modules, pneumatic - left, type ME02

Variants

Supply port (P) 1	Connection X	Exhaust port (R/S) 3/5
G ¼	M5	G ¼
D 10	D 4	D 10
NPT ¼	M5	NPT ¼

Connection X

Operating mode	Configuration of X
Standard	Exhaust air from pilot valve
Auxiliary control air	Connection for auxiliary control air Operation with auxiliary control air is optional

Drawing showing variants

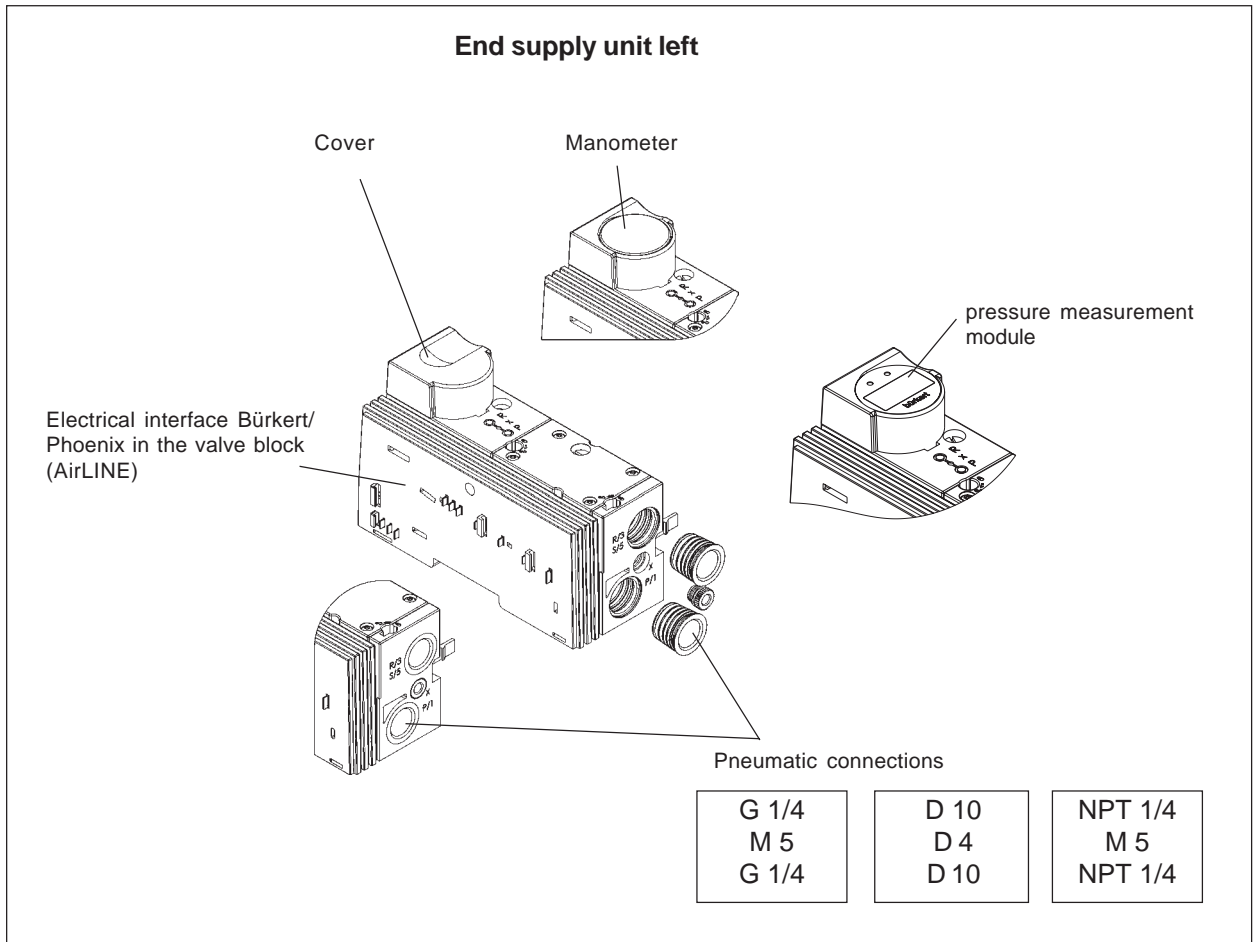

MAN 1000010120 EN Version: K Status: RL (released | freigegeben) printed: 23.04.2025

Technical data

Housing dimensions (width x height x depth)	61 mm x 71 mm x 120 mm (incl. snap-on hooks)
Weight	without Electronic pressure module 220 g with Electronic pressure module 247 g
Permissible temperature (storage/transport)	-20 °C to +60 °C
Permissible air humidity	75% mean, 85% occasionally



ATTENTION!

In the range of 0 to +55 °C, suitable precautions must be taken against elevated humidity (> 85%).
Slight condensation of short duration on the outside of the housing is permissible, e.g. when the terminal is brought from a vehicle into a closed room.

Permissible air pressure (operation)	80 kPa to 106 kPa (up to 2000 m üNN)
Permissible air pressure (storage/transport)	70 kPa to 106 kPa (up to 3000 m üNN)
Protection type	IP 20 to IEC 60529
Protection class	Class 3 to VDE 106, IEC 60536

Performance characteristics seen from the overall system

	Cover / Manometer	Electronic pressure measurement module
logical	no process diagramm, hence no address required	adequate electrical module
mechanical	47 mm installation dimension	47 mm installation dimension
electrical	no current consumption	66 mA
fluidic	left-hand limitation of valve block, left-hand supply	left-hand limitation of valve block, left-hand supply

Conector modules, pneumatic - left, type ME03

Variants

Supply port (P) 1	Connection X	Exhaust port (R/S) 3/5
without manometer		
G 3/8	G 1/8	G 3/8
NPT 3/8	NPT 1/8	NPT 3/8
with manometer		
G 3/8	G 1/8	G 3/8
NPT 3/8	NPT1/8	NPT 3/8

Connection X

Operating mode	Configuration of X
Standard	Exhaust air from pilot valve
Auxiliary control air	Connection for auxiliary control air Operation with auxiliary control air is optional

Drawing showing variants

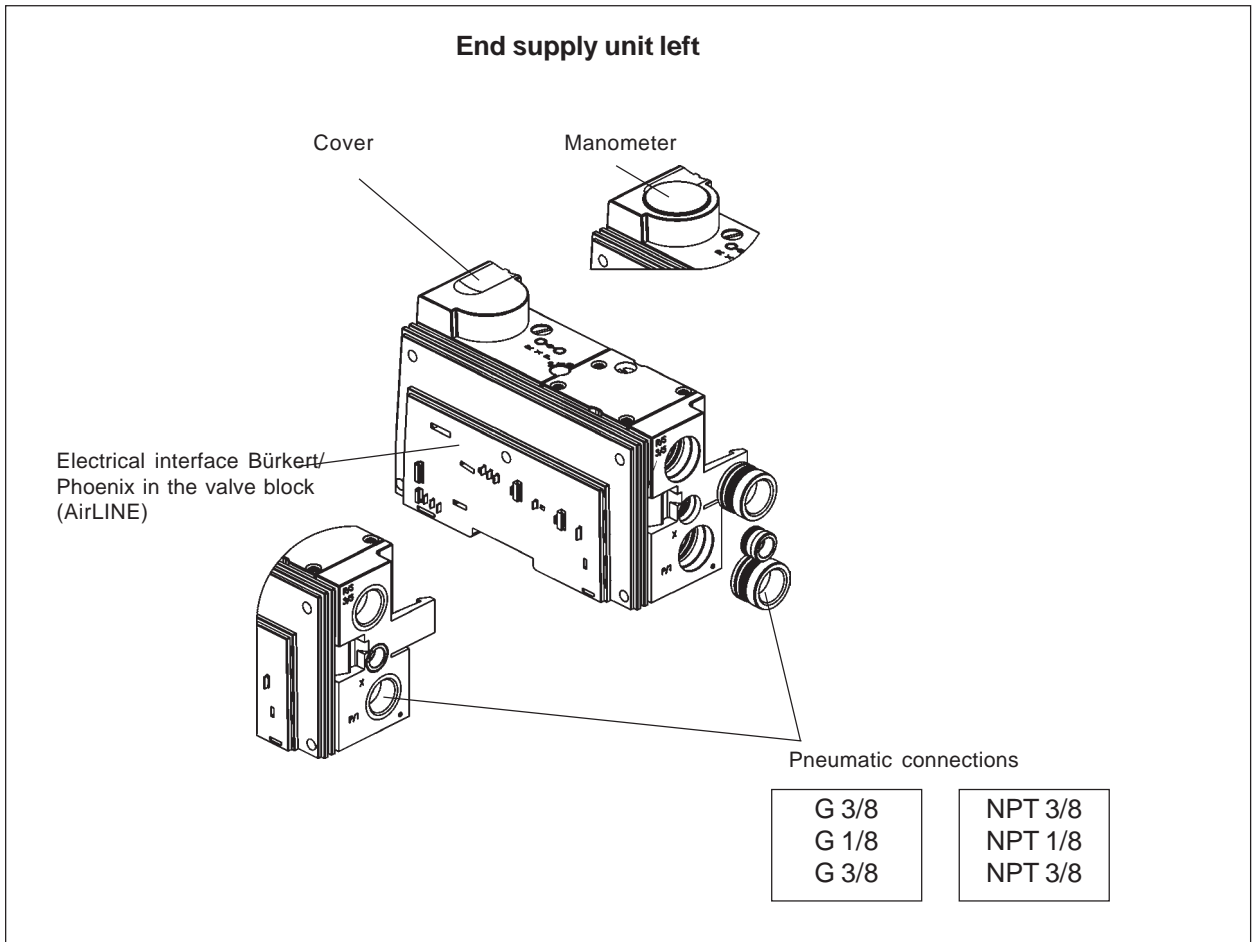

Technical data

Housing dimensions (width x height x depth)	74 mm x 93 mm x 142 mm (incl. snap-on hooks)
Weight	400 g
Permissible temperature (storage/transport)	-20 °C to +60 °C
Permissible air humidity	75% mean, 85% occasionally



ATTENTION!

In the range of 0 to +55 °C, suitable precautions must be taken against elevated humidity (> 85%).
Slight condensation of short duration on the outside of the housing is permissible, e.g. when the terminal is brought from a vehicle into a closed room.

Permissible air pressure (operation)	80 kPa to 106 kPa (up to 2000 m üNN)
Permissible air pressure (storage/transport)	70 kPa to 106 kPa (up to 3000 m üNN)
Protection type	IP 20 to IEC 60529
Protection class	Class 3 to VDE 106, IEC 60536

Performance characteristics seen from the overall system

The left connection module is electrically passive.

- logical No process diagram, hence no address required
- mechanical 56 mm installation dimension
- electrical No current consumption
- fluidic Left-hand limitation of valve block, left-hand supply

Connector modules, pneumatic - middle, type ME02

Variants

Supply port (P) 1	Connection X	Exhaust port (R/S) 3/5
without manometer		
G ¼	M5	G ¼
D 10	D 4	D 10
NPT ¼	M5	NPT ¼
with manometer		
G ¼	M5	G ¼
D 10	D 4	D 10
NPT ¼	M5	NPT ¼

Connection X

Operating mode	Configuration of X
Standard	Exhaust air from pilot valve
Auxiliary control air	Connection for auxiliary control air Operation with auxiliary control air is optional

Drawing showing variants

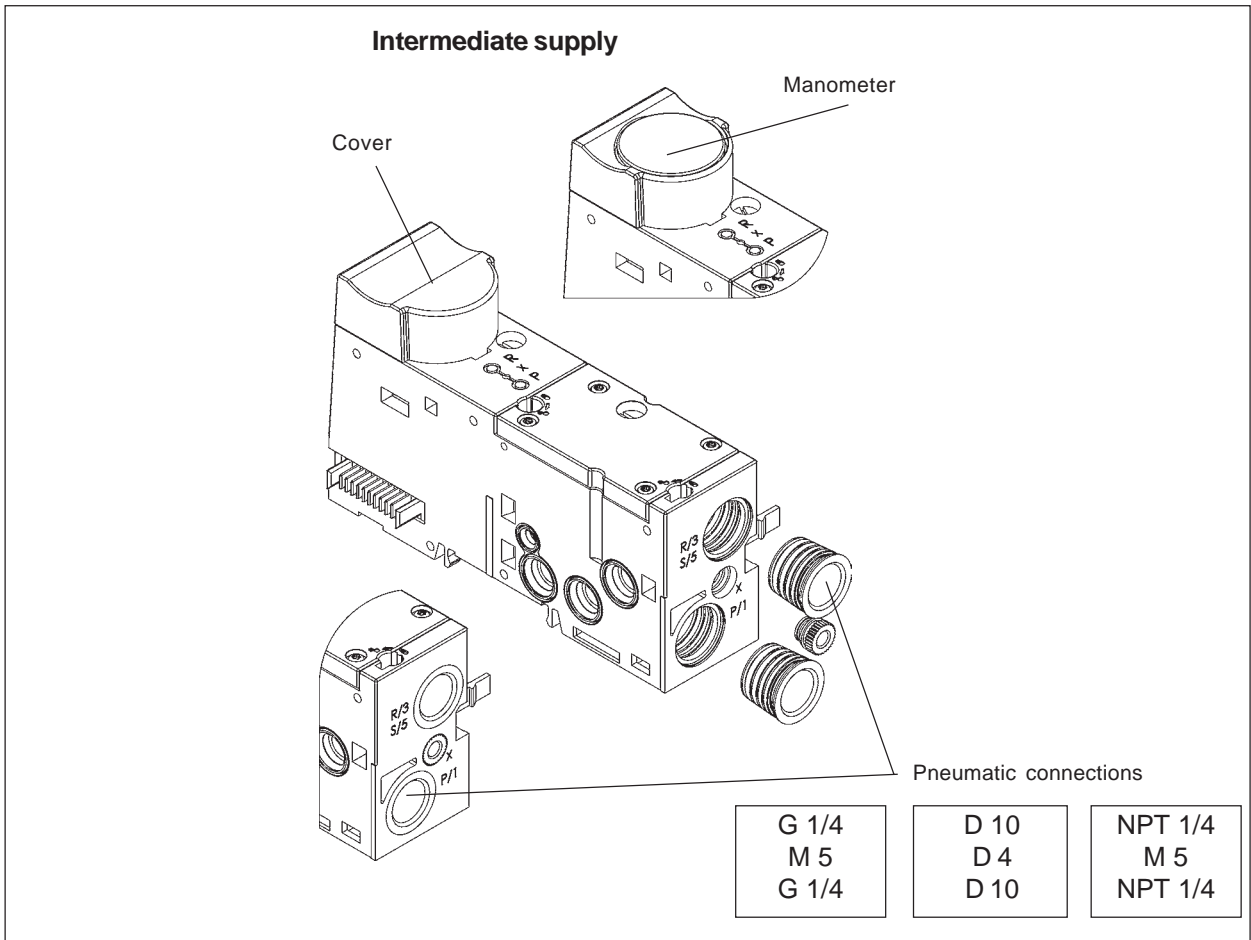

Technical data

Housing dimensions (width x height x depth)	52 mm x 71 mm x 119 mm (incl. snap-on hooks)
Weight	118 g
Permissible temperature (storage/transport)	-20 °C to +60 °C
Permissible air humidity	75% mean, 85% occasionally



ATTENTION!

In the range of 0 to +55 °C, suitable precautions must be taken against elevated humidity (> 85%).

Slight condensation of short duration on the outside of the housing is permissible, e.g. when the terminal is brought from a vehicle into a closed room.

Permissible air pressure (operation)	80 kPa to 106 kPa (up to 2000 m üNN)
Permissible air pressure (storage/transport)	70 kPa to 106 kPa (up to 3000 m üNN)
Protection type	IP 20 to IEC 60529
Protection class	Class 3 to VDE 106, IEC 60536

Performance characteristics seen from the overall system

The intermediate supply is electrically passive.

- logical No process diagram, hence no address required
- mechanical 33 mm add-on dimension
- electrical No current consumption
- fluidic Additional supply

Connector modules, pneumatic - middle, TYPE ME03

Variants

Supply port (P) 1	Connection X	Exhaust port (R/S) 3/5
without manometer		
G 3/8	G 1/8	G 3/8
NPT 3/8	NPT 1/8	NPT 3/8
with manometer		
G 3/8	G 1/8	G 3/8
NPT 3/8	NPT1/8	NPT 3/8

Connection X

Operating mode	Configuration of X
Standard	Exhaust air from pilot valve
Auxiliary control air	Connection for auxiliary control air Operation with auxiliary control air is optional

Drawing showing variants

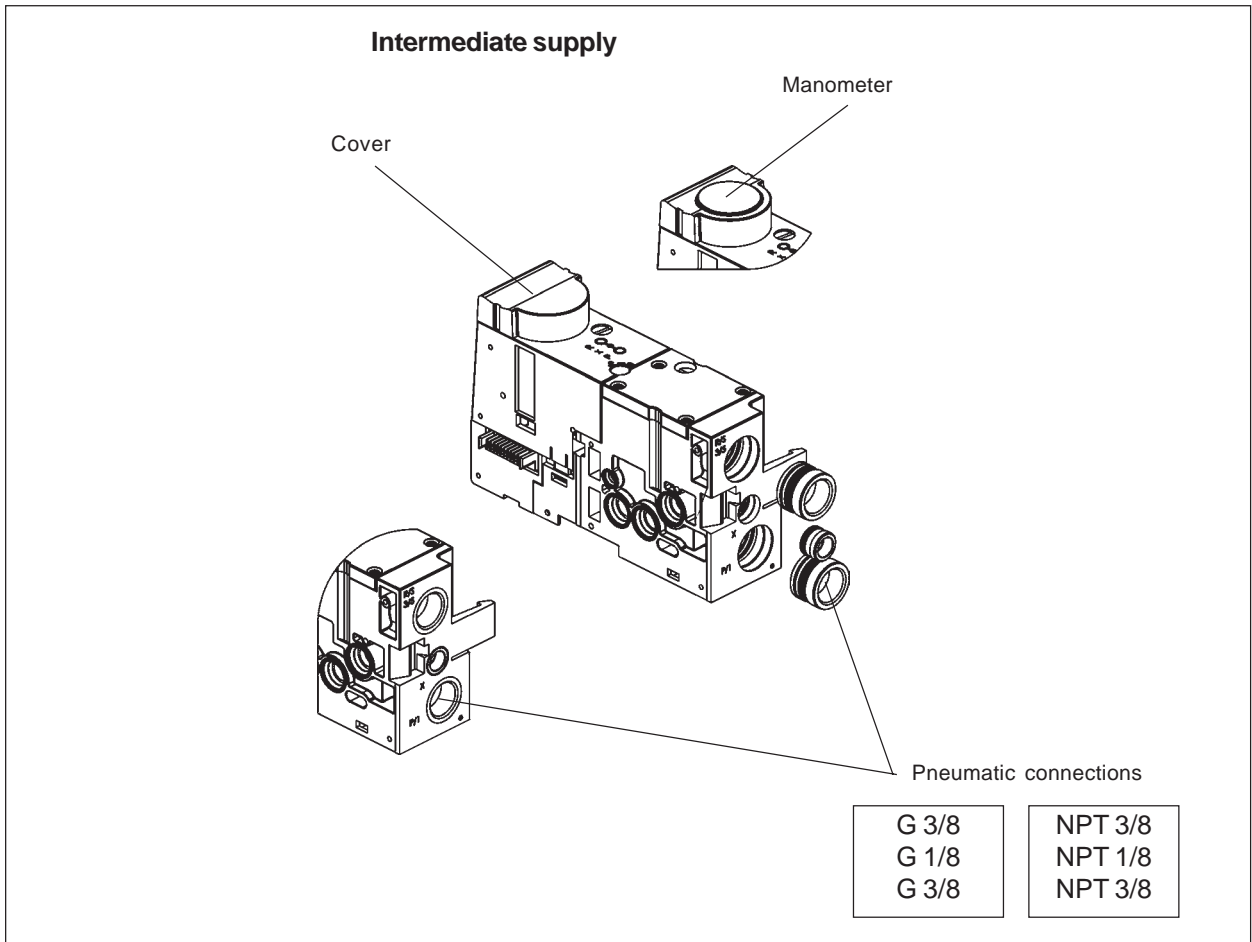

Technical data

Housing dimensions (width x height x depth)	66 mm x 93 mm x 142 mm (incl. snap-on hooks)
Weight	335 g
Permissible temperature (storage/transport)	-20 °C to +60 °C
Permissible air humidity	75% mean, 85% occasionally



ATTENTION!

In the range of 0 to +55 °C, suitable precautions must be taken against elevated humidity (> 85%).
Slight condensation of short duration on the outside of the housing is permissible, e.g. when the terminal is brought from a vehicle into a closed room.

Permissible air pressure (operation)	80 kPa to 106 kPa (up to 2000 m üNN)
Permissible air pressure (storage/transport)	70 kPa to 106 kPa (up to 3000 m üNN)
Protection type	IP 20 to IEC 60529
Protection class	Class 3 to VDE 106, IEC 60536

Performance characteristics seen from the overall system

The intermediate supply is electrically passive.

- logical No process diagram, hence no address required
- mechanical 42 mm add-on dimension
- electrical No current consumption
- fluidic Additional supply

Connector modules, pneumatic - right, type ME02

Variants

Supply port (P) 1	Connection X	Exhaust port (R/S) 3/5
without manometer		
G ¼	M5	G ¼
D 10	D 4	D 10
NPT ¼	M5	NPT ¼
with manometer		
G ¼	M5	G ¼
D 10	D 4	D 10
NPT ¼	M5	NPT ¼

Connection X

Operating mode	Configuration of X
Standard	Exhaust air from pilot valve
Auxiliary control air	Connection for auxiliary control air Operation with auxiliary control air is optional

Drawing showing variants

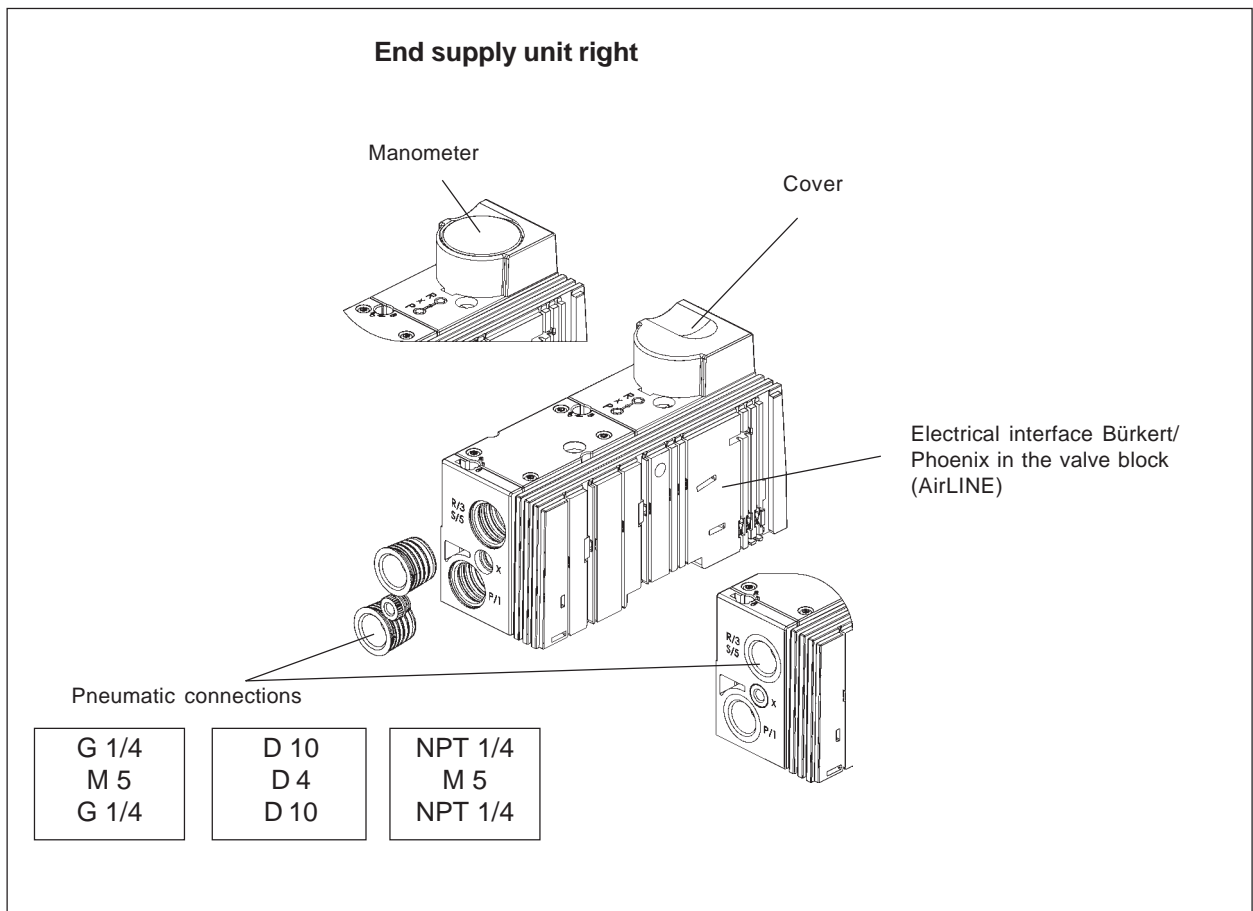

Technical data

Housing dimensions (width x height x depth)	54 mm x 71 mm x 119 mm
Weight	220 g
Permissible temperature (storage/transport)	-20 °C to +60 °C
Permissible air humidity	75% mean, 85% occasionally

**ATTENTION!**

In the range of 0 to +55 °C, suitable precautions must be taken against elevated humidity (> 85%).

Slight condensation of short duration on the outside of the housing is permissible, e.g. when the terminal is brought from a vehicle into a closed room.

Permissible air pressure (operation)	80 kPa to 106 kPa (up to 2000 m üNN)
Permissible air pressure (storage/transport)	70 kPa to 106 kPa (up to 3000 m üNN)
Protection type	IP 20 to IEC 60529
Protection class	Class 3 to VDE 106, IEC 60536

Performance characteristics seen from the overall system

The right connection module is electrically passive.

- logical	No process diagram, hence no address required
- mechanical	47 mm installation dimension
- electrical	No current consumption
- fluidic	Right-hand limitation of valve block, right-hand supply

Connector modules, pneumatic - right, type ME03

Variants

Supply port (P) 1	Connection X	Exhaust port (R/S) 3/5
without manometer		
G 3/8	G 1/8	G 3/8
NPT 3/8	NPT 1/8	NPT 3/8
with manometer		
G 3/8	G 1/8	G 3/8
NPT 3/8	NPT 1/8	NPT 3/8

Connection X

Operating mode	Configuration of X
Standard	Exhaust air from pilot valve
Auxiliary control air	Connection for auxiliary control air Operation with auxiliary control air is optional

Drawing showing variants

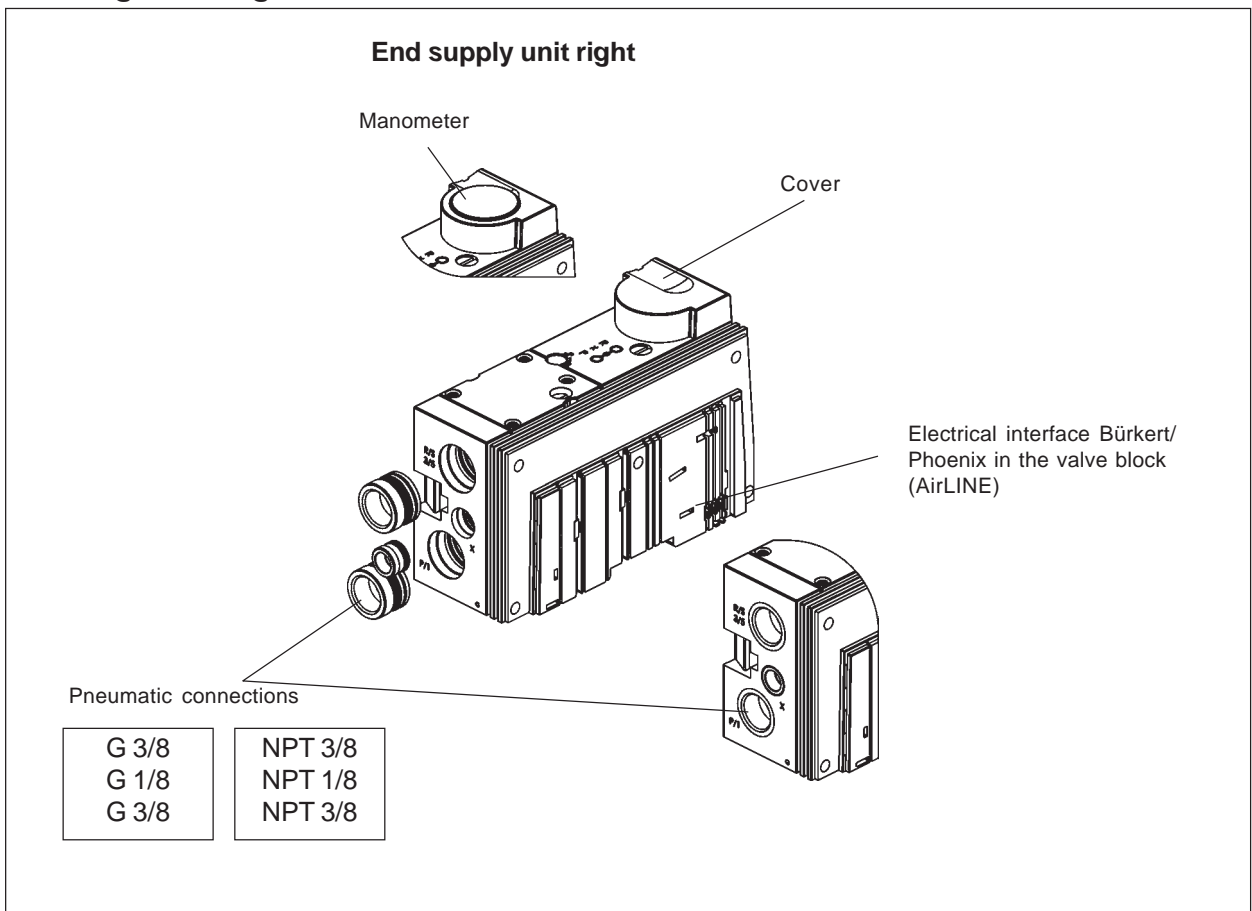

Technical data

Housing dimensions (width x height x depth)	63 mm x 93 mm x 142 mm
Weight	390 g
Permissible temperature (storage/transport)	-20 °C to +60 °C
Permissible air humidity	75% mean, 85% occasionally



ATTENTION!

In the range of 0 to +55 °C, suitable precautions must be taken against elevated humidity (> 85%).
Slight condensation of short duration on the outside of the housing is permissible, e.g. when the terminal is brought from a vehicle into a closed room.

Permissible air pressure (operation)	80 kPa to 106 kPa (up to 2000 m üNN)
Permissible air pressure (storage/transport)	70 kPa to 106 kPa (up to 3000 m üNN)
Protection type	IP 20 to IEC 60529
Protection class	Class 3 to VDE 106, IEC 60536

Performance characteristics seen from the overall system

The right connection module is electrically passive.

- logical No process diagram, hence no address required
- mechanical 56 mm installation dimension
- electrical No current consumption
- fluidic Right-hand limitation of valve block, right-hand supply

ELECTRONIC PRESSURE MEASUREMENT MODULE (PMM)

General description

The electronic pressure measurement module (PMM) is connected to the adjacent modules by an electrical interface and communicates via the field bus.

The pressure value is shown on the 7-segment display. At the same time, this value can be called up in the overriding control system.

The module requires two input data bytes. The first data byte is used as a status byte, the second for the actual pressure value.

Electronic pressure measurement module (PMM)

Features

Measurement units, selectable	bar, kPa ¹⁾ , psi
Pressure range, absolute	-1 to 10 bar
Media	clean, dry air, non-corrosive gases
Module configuration	via field bus (pressure unit, threshold value, degree of smoothing, reaction time)
Warning message	when pressure too high or too low
Visualization	on local display

¹⁾ As a result of the 3-digit display, the display ranges from -90 kPa to 990 kPa (corresponding to -0.9 to 9.9 bar) on the kPa setting.

Factory settings (as delivered)

Pressure unit	bar	(0x00)
Threshold values		
- minimum value	2 bar / 200 kPa	(0x14)
- maximum value	8 bar / 800 kPa	(0x50)
Sensitivity	20	(0x14)
Reaction time	3 s	(0x65)

Input and output data

The pressure measurement module is controlled via 2 bytes of input data and 2 bytes of output data. The first byte is the control byte of the output data (master) and the status byte of the input data (master). In normal operation the status byte corresponds to the response of the control byte of the previous interrogation. The second byte is the data byte.

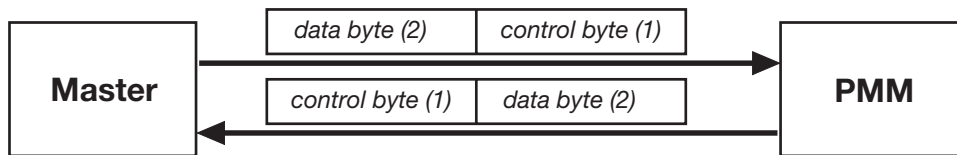

Control byte

The difference between the process and parametrization data is determined by the status bit of the control byte.

- Status bit 0 → process data
- Status bit 1 → parametrization data

AS	FB	15	14	13	12	11	10
-----------	-----------	-----------	-----------	-----------	-----------	-----------	-----------

AS: status bit (process or parametrization data)
 FB: error bit
 15-10: bits containing further information

Structure of the control byte

Process data

Process data transmits the pressure value¹⁾ of the system and the units set up in the module.

Calling up process data

When you call up process data, the control byte must assume a value between 0x00 and 0x7F (status bit = 0). The data byte is not taken into account.

The status byte of the response depends on the unit set on the local display. The data byte supplies the pressure value¹⁾.

Unit on display	Status byte of response
bar →	0x38
kPa →	0x39
psi →	0x3A

¹⁾ Pressure value: value in bar x 10 (without decimal point)

Parametrization data

The following settings are possible via the parametrization data:

- pressure unit to be shown on the local display,
- upper and lower threshold limits,
- reaction time,
- sensitivity (degree of smoothing) of the pressure measurement module.

Setting the parametrization data

The parameters must be set only once during operation. They are then stored in the EEPROM.

The setting of the control byte and the permissible data byte for a certain parametrization (e. g. *writing unit of pressure display* → *control byte: 0x91*) is explained in the following (see also table *Parametrization*).

Example for setting the parametrization data (Simatic Manager S7 / SPS CPU313C-2DP)

Controlling / forcing the variables:

- Open the application *Simatic Manager S7*.
- Select: *Target Systems / Observe Variable / Control*. The window *Var – Variables Table 1* will be opened.
- Enter into the table the variables to be observed, input bytes of the SPS of PMM [e. g. EB10 (= Status) and EB11 (= data)], as well as the output bytes AB10 and AB11.
- Select: *Display Variable / Forcing Values*.
The menu *Forcing Values* is displayed.
- Enter into the table the variables to be written, the output bytes of the SPS (AB10 = control byte and AB11 = data byte) with the forcing values.
Confirm with *Continue*.
- Select: *Variable / Force* and confirm with *OK*
- To stop forcing, select *Variables / Delete Force*.



NOTE

|| Also check whether and how the hardware used (SPS) supports Control / Forcing.

Alternatives

In principle, all Profibus masters are suitable for parametrizing the pressure measurement module. But test the selected software in each case.



ATTENTION!

After one cycle of parametrizing data, an acknowledge telegram (0xAA) or a process data telegram must be sent from the master. Only then can a new parametrizing data telegram be recognized.

Setting the control and data bytes (overview)

Serial no.	Setting	Write	Read	Control byte	Data byte	Explanation
1	Unit of pressure display on pressure module ¹	X		0x91	(0) to (2) [0x00:0x02]	Unit Displayed in bar, kPa or psi 0x00 (0) = bar, 0x01 (1) = kPa, 0x02 (2) = psi
			X	0x81	dc	The unit set in the module is read out. Return value of data byte: 0x00 = bar, 0x01 = kPa, 0x02 = psi
2	Lower threshold value ²	X		0x92	(-10) to (99) [0xF6:0x63]	Range of values: -10 to 99 (-1 to 9.9 bar) The lower threshold value must be smaller than the upper threshold value.
			X	0x82	dc	The lower threshold value set in the module is read out. Return value of data byte: -10 to 99 (-1 to 9.9 bar)
3	Upper threshold value ²	X		0x93	(-9) to (100) [0xF7:0x64]	Range of values: -9 to 100 (-0.9 to 10 bar) The upper threshold value must be greater than the lower threshold value.
			X	0x83	dc	The upper threshold value set in the module is read out. Return value of data byte: -9 to 100 (-0.9 to 10 bar)
4	Reaction time ²	X		0x94	(0) to (255) [0x00:0xFF]	Range of values Value = 0 threshold treatment deactivated Value = 1... 255 threshold treatment activated Reaction time that may be set: 0 ms to 7.62 s (in 30 ms steps) Calculation reaction time = (value-1) x 30 ms
			X	0x84	dc	Feedback value data byte 0 ... 255 - set threshold value (see above)
5	Sensitivity ² (degree of smoothing)	X		0x9F	(1) to (100) [0x01:0x64]	Range of values: 1 to 100 The larger the value, the more strongly the pressure value last measured is included in the mean value calculation (PT-1-filter), the higher is the sensitivity and the lower is the degree of smoothing. $\text{Value} \approx \text{sensitivity} \approx \frac{1}{\text{degree of smoothing}}$ Value 100, i.e. the pressure value measured is weighted to 100 % and the previous measurement to 0 %. In this case the filter is deactivated. The sampling frequency of the pressure measurement module is 50 Hz (TA = 20 ms).
			X	0x8F	dc	Return value of data byte: 1 to 100
6	Acknowledge			0xAA	dc	Acknowledge telegram is required between different parametrizations. Instead of this, one can request process data.

¹ see Unit of pressure display

² see Threshold values and reaction time

dc: don't care

() decimal values in brackets

Unit of pressure display

The pressure value is always sent over the bus in kPa. The pressure unit can only be changed on the local unit.

Threshold values and reaction time

If the measured value exceeds the upper threshold value (or lies below the lower threshold value), after expiry of a set reaction time warning messages are sent via the bus (see chapter *Warning and Error Messages*).

At the same time, the pressure value on the local display alternates with the message *HI* (upper threshold value) or *LO* (lower threshold value). If the pressure returns to the proper range before expiry of the reaction time, the watchdog is reset. After the next excursion outside the limits, the reaction time again runs for the full period before warning messages are issued.

If the reaction time is set to zero, the threshold treatment is deactivated, i.e. the set threshold values are without effect.

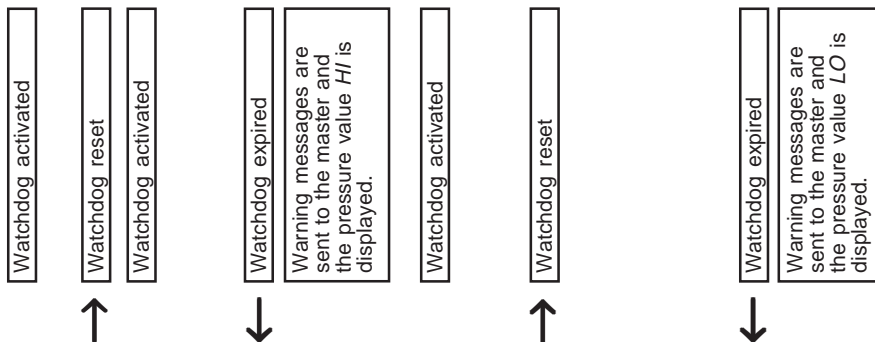
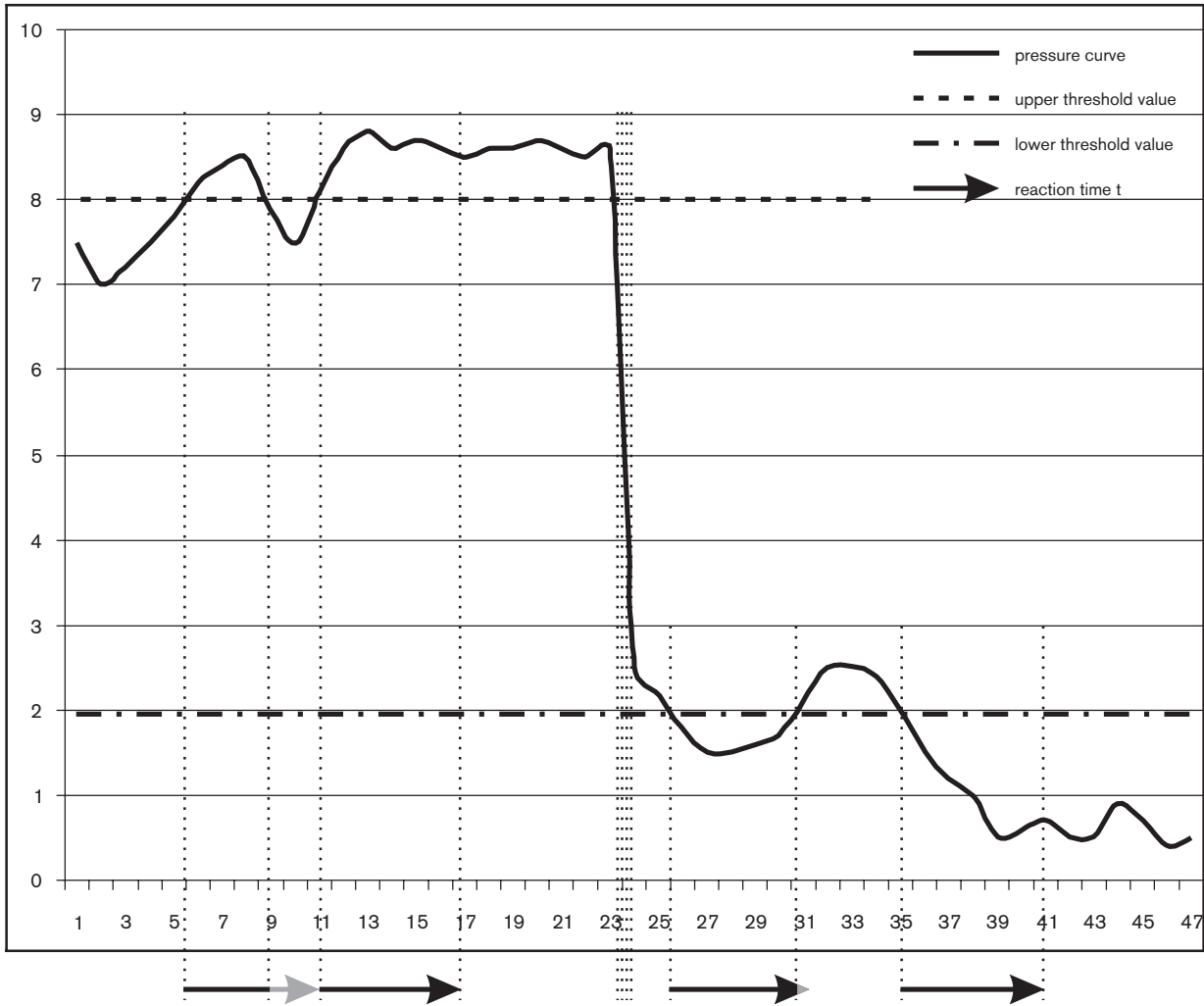

MAN 1000010120 EN Version: K Status: RL (released | freigegeben) printed: 23.04.2025

Sensitivity (degree of smoothing)

The diagram shows the step responses (from 1 to 0 / from 0 to 1) of the filter with various sensitivity parameters (degrees of smoothing).

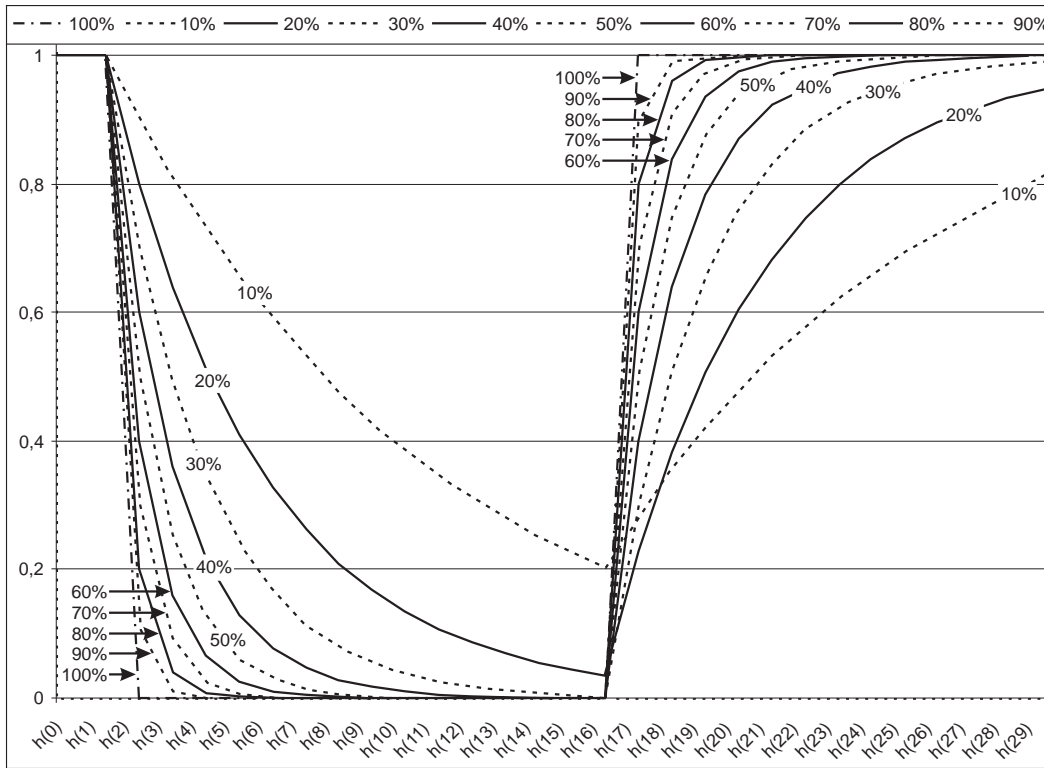

Explanation of the characteristic curves

The sensitivity parameter is the procentual weighting of the last measured pressure value.

Example:

Sensitivity parameter = 90 (see also 90 % characteristic)

The desired mean pressure value is calculated from the formula:

$$P_A(k) = 0.1 P_A(k-1) + 0.9 P_E(k) \quad \text{or} \quad P_A(k) = 10\% P_A(k-1) + 90\% P_E(k)$$

$P_A(k)$ is the mean pressure value to be calculated (filter output)

$P_A(k-1)$ is the last calculated mean pressure value (filter output) and

$P_E(k)$ is the previously measured pressure (filter input).

Sensitivity parameter	Explanation
10	Corresponds to the 10 % characteristic: filter is sluggish, very strong smoothing $P_A(k) = 90\% P_A(k-1) + 10\% P_E(k)$
50	Corresponds to the 50 % characteristic: strong smoothing $P_A(k) = 50\% P_A(k-1) + 50\% P_E(k)$
100	Corresponds to the 100 % characteristic: no smoothing $P_A(k) = 0\% P_A(k-1) + 100\% P_E(k)$

Warning and error messages

Warning and error messages (telegrams sent from the pressure module) may be issued as a result of incorrect parametrization or excursions outside the limits. They contain status bytes specially defined for the case for the case of errors, whereby status and control byte (previously sent by the master) are not identical. In some cases, errors are signalled additionally on the local display.

Error	Status byte	Display	Remarks
Parameter value nonvalid	0xE2	none	application error
EEPROM cannot be written on	0xE3	none	system error ¹⁾
Value above upper limit of pressure range (10 bar)	0xE4	<i>P o</i> is shown continuously	application error
Value below lower limit of pressure range (-1 bar)	0xE5	<i>P u</i> is shown continuously	system error ¹⁾
Value above upper threshold value	0x42	<i>H I</i> and pressure value flash alternately	warning
Value below lower threshold value	0x43	<i>L O</i> and pressure value flash alternately	warning

¹⁾ If system errors occur frequently, a repair may be necessary.

BASIC ELECTRONIC MODULES

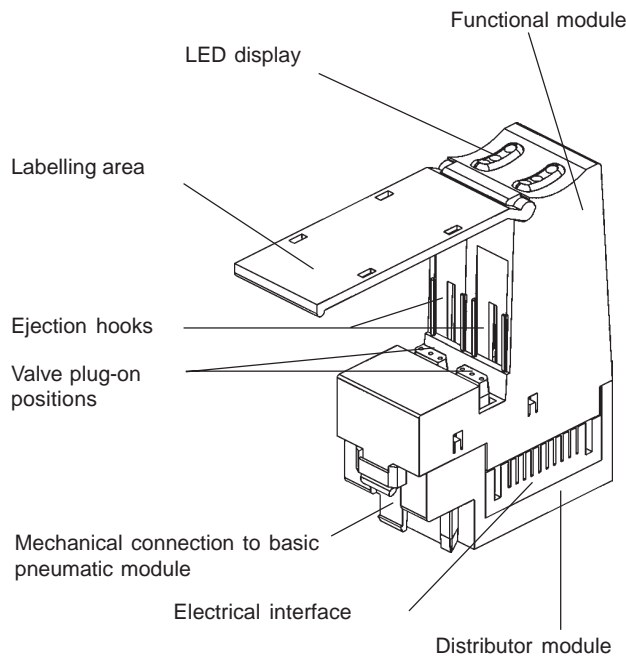

General description

The basic electronic module is connected to the adjacent modules via its electrical interface. In this way it receives both voltage supply and control signals for the valves on the plug-on positions.

The basic electronic modules and hence the valve units may be controlled as digital output modules/ terminals. More detailed information is to be found in the chapter *Commissioning*.

Variants

The valves which can be used with AirLine Type 8644 have different connection configurations, valve separations and control characteristics. For this reason, the basic electronic module is available in different versions.

Example of a basic electronic module (Type ME02/2-fold)

Versions available

Variants	2fold monostable	2fold bistable	3fold 10 mm monostable	4fold monostable	8fold monostable
ME02	X	X			X
ME03	X	X	X	X	

Possible combinations (basic electronic module / valve)

Basic module type		Add-on dimension	Valve positions	Valve type	Function	ID -code	Lengthen-code
ME02	2fold mono*	11 mm	2	6524	3/2-way	BD hex (189 dec)	C2 hex
				6525	5/2-way		
	2fold bi*	11 mm	2	0460	5/3-Wege		41 hex
					5/2-way pulse		
	8fold mono	11 mm	8	6524	3/2-way		81 hex
					6525		
ME03	2fold mono	16,5 mm	2	6526	3/2-way	BD hex (189 dec)	C2 hex
				6527	5/2-way		
	2fold bi	16,5 mm	2	0461	5/3-way		41 hex
					5/2-way pulse		
	3fold **	11 mm	3	6524	3/2-way		
				6525	5/2-way		
	4fold mono	16,5 mm	4	6526	3/2-way		
				6527	5/2-way		

* mono = monostable, bi = bistable

** with 10 mm valves

The documentation of the overall system 8644 AirLINE Phoenix can be found on the Internet or can be ordered on paper under the identification number 804636.

Basic electronic module ME02 / 2-fold monostable

Construction

A basic electronic module consists of a distributor module (back-wall bus) and a function module. Both modules are contacted via a 14-pole board-to-board connector.

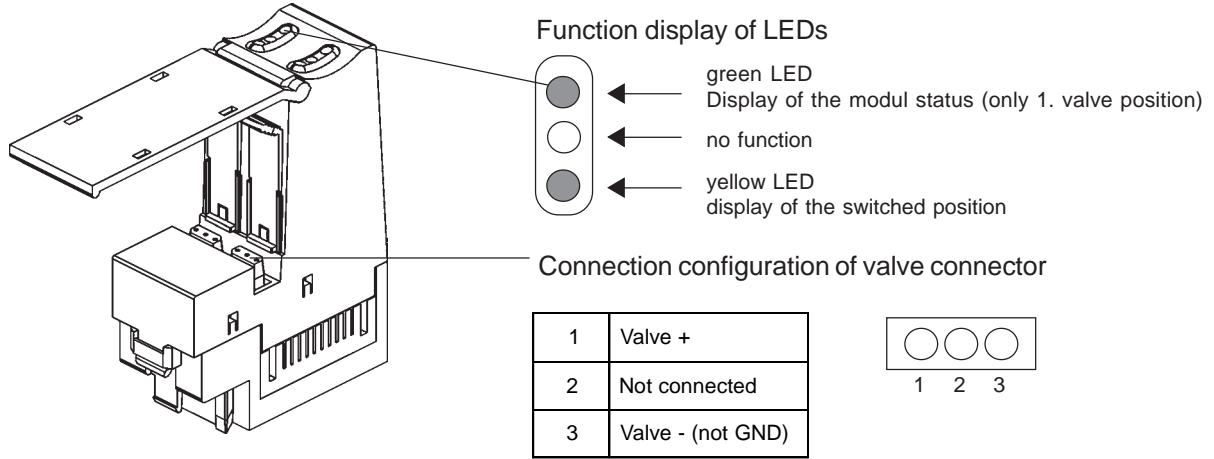

Possible combinations with valve types

Basic module type	Add-on dimension	Valve positions	Valve type	Function
ME02 2-fold monostable	11 mm	2	6524	3/2-way
			6525	5/2-way

Technical data	ME02 / 2-fold monostable
Dimensions WxHxD	22x70,5x52 mm
Weight	38 g
Storage temperature	-20 to +60° C
Rated voltage under load	DC 24 V
No. of valve outputs	2
Current consumption per valve position during switching	43 mA
Current consumption per valve position after ca. 65 ms	26 mA
Current consumption from the back-wall bus	max. 15 mA
Display of valve status	1 yellow LED per valve position
Display of modul status	1 green LED per modul (1.valve position)
Power dissipation of module in moment of switching	2 W
Power dissipation of module 65 ms after switching procedure (2x 0.25W at resistors, 2x 0.25W at valve coils)	1 W

Basic electronic module ME02 / 8-fold monostable

Construction

A basic electronic module consists of a distributor module (back-wall bus) and a function module. Both modules are contacted via a 14-pole board-to-board connector.

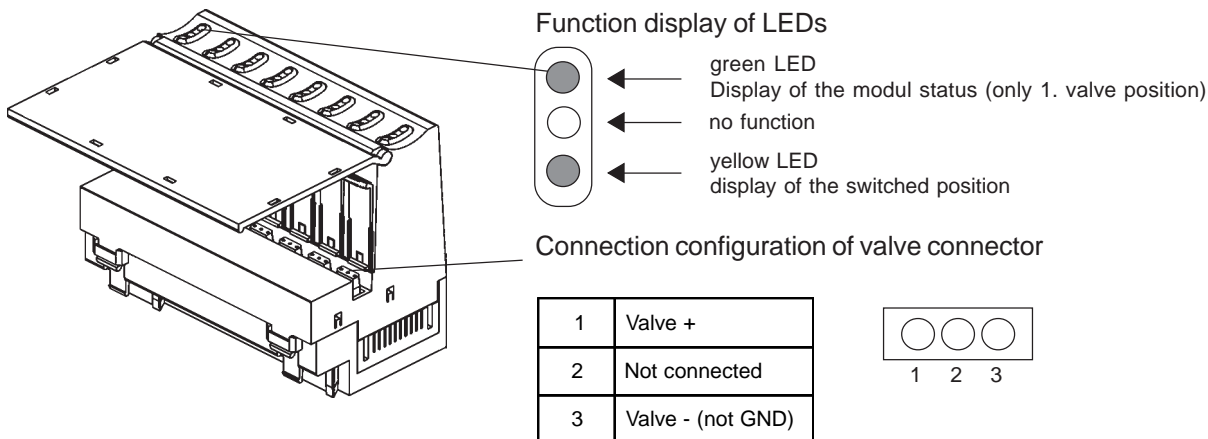

Possible combinations with valve types

Basic module type	Add-on dimension	Valve positions	Valve type	Function
ME02 8-fold monostable	11 mm	8	6524	3/2-way
			6525	5/2-way

Technical data	ME02 / 8-fold monostable
Dimensions WxHxD	88x70,5x52 mm
Weight	94 g
Storage temperature	-20 to +60° C
Rated voltage under load	DC 24 V
No. of valve outputs	8
Current consumption per valve position during switching	43 mA
Current consumption per valve position after ca. 65 ms	26 mA
Current consumption from the back-wall bus	max. 15 mA
Display of valve status	1 yellow LED per valve position
Display of modul status	1 green LED per modul (1. valve position)
Power dissipation of module in moment of switching	4 W
Power dissipation of module 65 ms after switching procedure (2x 0.25W at resistors, 2x 0.25W at valve coils)	2 W

Basic electronic module ME02 / 2-fold bistable

Construction

A basic electronic module consists of a distributor module (back-wall bus) and a function module. Both modules are contacted via a 14-pole board-to-board connector.

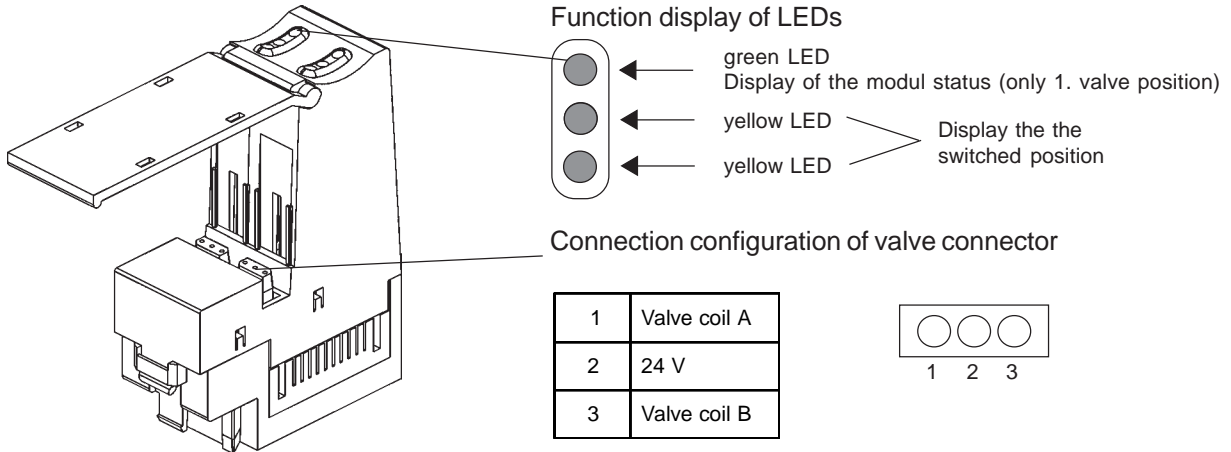

Possible combinations with valve types

Basic module type	Add-on dimension	Valve positions	Valve type	Function
ME02 2-fold bistable	11 mm	2	0460	5/3-way
				5/2-way pulse

Technical data	ME02 / 2-fold bistable
Dimensions WxHxD	22x70,5x52 mm
Weight	38 g
Storage temperature	-20...+60° C
Rated voltage under load	DC 24 V
No. of valve outputs	2
Current consumption per valve position	38 mA
Current consumption from the back-wall bus	max. 15 mA
Display of valve status	1 yellow LED per valve position
Display of modul status	1 green LED per modul (1. valve position)
Power dissipation of module	1,8 W

Basic electronic module ME03 / 2-fold monostable

Construction

A basic electronic module consists of a distributor module (back-wall bus) and a function module. Both modules are contacted via a 14-pole board-to-board connector.

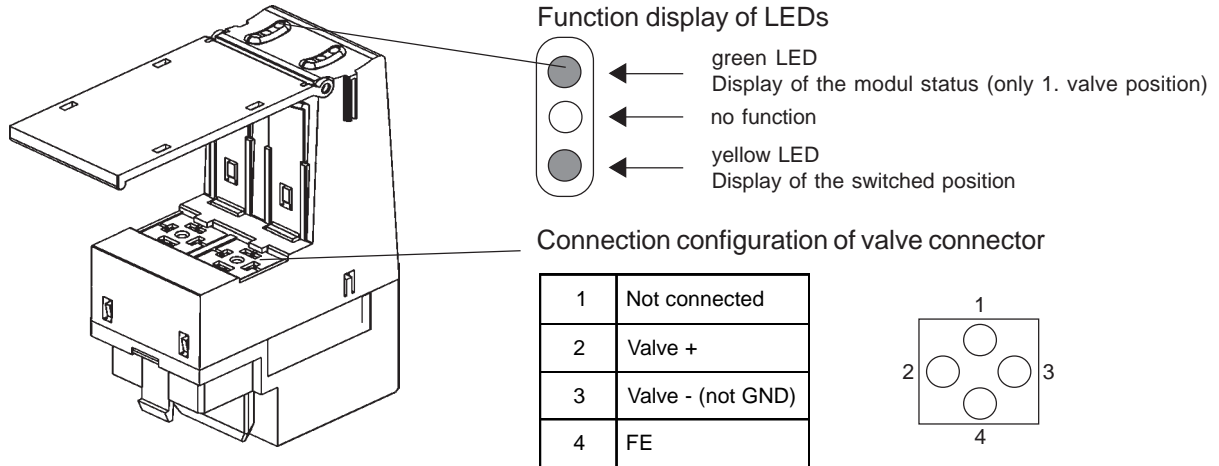

Possible combinations with valve types

Basic module type	Add-on dimension	Valve positions	Valve type	Function
ME03 2-fold monostable	16,5 mm	2	6526	3/2-way
			6527	5/2-way

Technical data	ME03 / 2-fold monostable
Dimensions WxHxD	33x93x60 mm
Weight	54,4 g
Storage temperature	-20 to +60° C
Rated voltage under load	DC 24 V
No. of valve outputs	2
Current consumption per valve position during switching	96 mA
Current consumption per valve position after ca. 400 ms	48 mA
Current consumption from the back-wall bus	max. 15 mA
Display of valve status	1 yellow LED per valve position
Display of modul status	1 green LED per modul (1. valve position)
Power dissipation of module in moment of switching	4 W
Power dissipation of module 400 ms after switching procedure (2 x 0,5 W at resistors , 2 x 0,5 W at valve coils)	2 W

Basic electronic module ME03 / 4-fold monostable

Construction

A basic electronic module consists of a distributor module (back-wall bus) and a function module. Both modules are contacted via a 14-pole board-to-board connector.

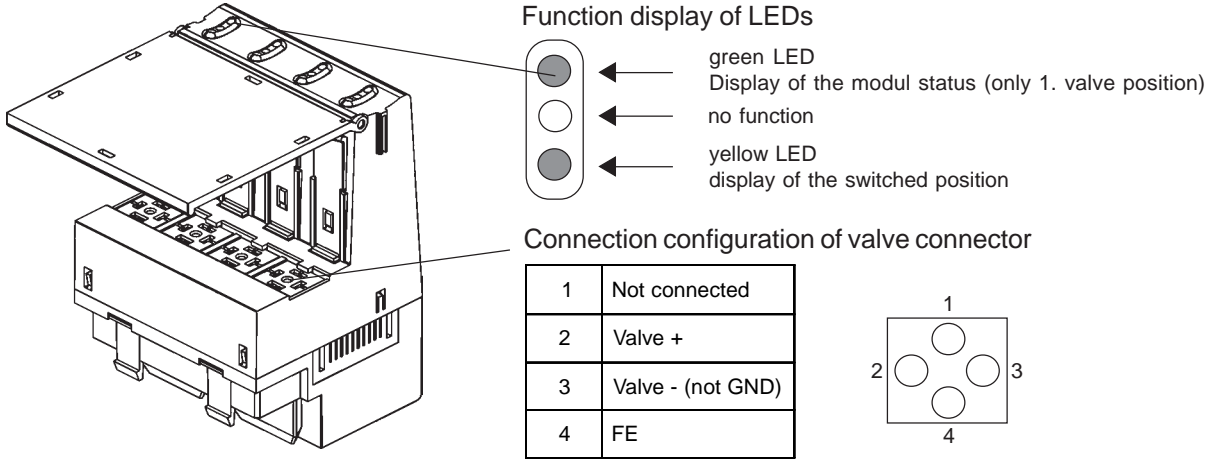

Possible combinations with valve types

Basic module type	Add-on dimension	Valve positions	Valve type	Function
ME03 4-fold monostable	16,5 mm	4	6526	3/2-way
			6527	5/2-way

Technical data	ME03 / 4-fold monostable
Dimensions WxHxD	66x93x60 mm
Weight	91,2 g
Storage temperature	-20 to +60° C
Rated voltage under load	DC 24 V
No. of valve outputs	4
Current consumption per valve position during switching	96 mA
Current consumption per valve position after ca. 400 ms	48 mA
Current consumption from back-wall bus	max. 15 mA
Display of valve status	1yellow LED per valve position
Display of modul status	1 green LED per modul (1. valve position)
Power dissipation of module in moment of switching	8 W
Power dissipation of module 400 ms after switching procedure (4x 0,5 W at resistors, 4x 0,5 Wat valve coils)	4 W

Basic electronic module ME03 / 3-fold 10 mm monostable

Construction

A basic electronic module consists of a distributor module (back-wall bus) and a function module. Both modules are contacted via a 14-pole board-to-board connector.

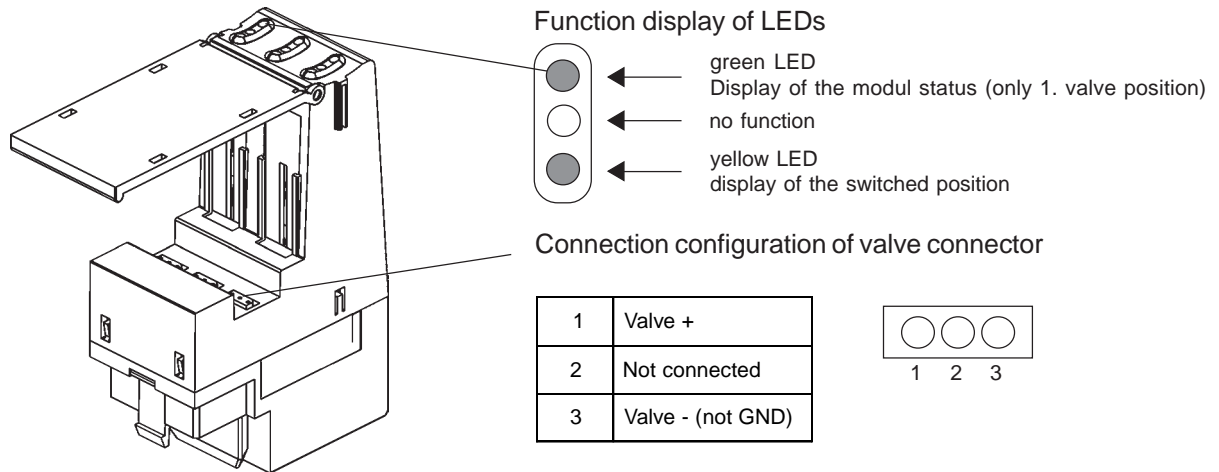

Possible combinations with valve types

Basic module type	Add-on dimension	Valve positions	Valve type	Function
ME03 3-fold with 10 mm monostable	11 mm	3	6524	3/2-way
			6525	5/2-way

Technical data	ME03 / 3-fold 10 mm monostable
Dimensions WxHxD	33x93x60 mm
Weight	51 g
Storage temperature	-20 to +60° C
Rated voltage under load	DC 24 V
No. of valve outputs	3
Current consumption per valve position during switching	43 mA
Current consumption per valve position after ca. 65 ms	26 mA
Current consumption from the back-wall bus	max. 15 mA
Display of valve status	1 yellow LED per valve position
Display of modul status	1 green LED per modul (1. valve position)
Power dissipation of module in moment of switching	3 W
Power dissipation of module 65 ms after switching procedure (3x 0,25 W at resistors, 3x 0,25 W at valve coils)	1,5 W

Basic electronic module ME03 / 2-fold bistable

Construction

A basic electronic module consists of a distributor module (back-wall bus) and a function module. Both modules are contacted via a 14-pole board-to-board connector.

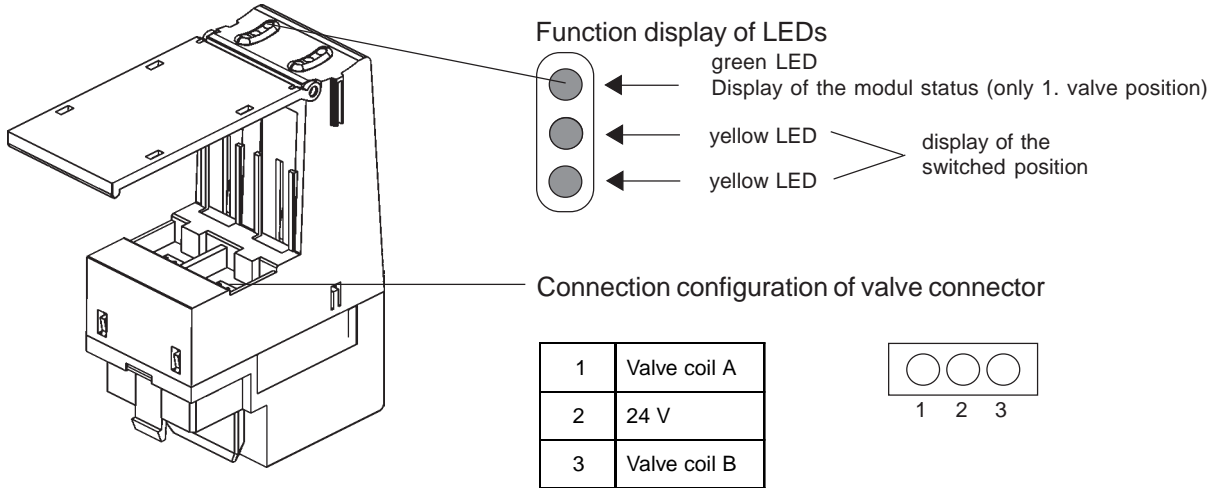

Possible combinations with valve types

Basic module type	Add-on dimension	Valve position	Valve type	Function
ME03 2-fold bistabile	16,5 mm	2	0461	5/3-way
				5/2-way pulse

Technical data	ME03 / 2-fold bistable
Dimensions WxHxD	33x93x60 mm
Weight	49,1 g
Storage temperature	-20 to +60° C
Rated voltage under load	DC 24 V
No. of valve outputs	2 x 2
Current consumption per valve position	38 mA
Current consumption from the back-wall bus	max. 15 mA
Display of valve status	1 yellow LED per valve position
Display of modul status	1 green LED per modul (1. valve position)
Power dissipation of module	1,8 W

BASIC PNEUMATIC MODULE

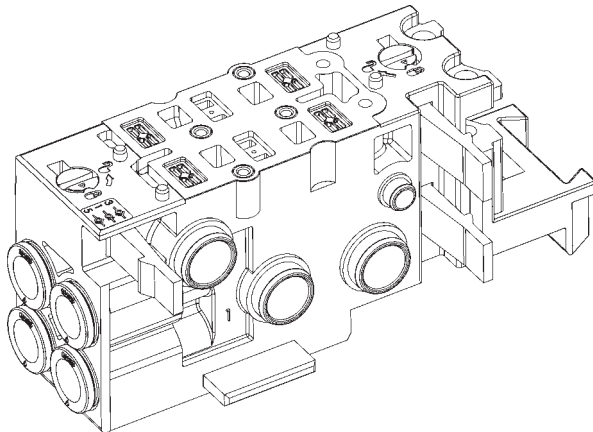

Example of a basic pneumatic module (type MP 11/2-fold)

General description

On the basic pneumatic module are to be found the service ports for subsequent applications. Several basic modules may be built up in a row by interlocking. Sealing from the outside is maintained. By using a bulkhead fitting, the P port may be sealed. Thus different working pressures can coexist in one valve block.

Variants

The different variants differ in the add-on dimension, number of valve locations, connection configuration of the valves, types of service port and the optional use of non-return valves.

Not all possible variants are realized.

Add-on dimension

Larger valves require the basic modules to be wider. This allows a higher flow rate to be obtained. At the present, the following add-on dimensions exist:

Variants	Add-on dimension [mm]	2-fold mono	2-fold bistable	3-fold	4-fold	8-fold
MP11	11	X*	X			X*
MP12	16,5	X	X	X	X	

* also available with pressure shut-off

Number of valve locations per module

Because of optimization for lower granularity, cost savings, design of valve units and loading of the electronics, modules with different numbers of valve locations make sense. (see table)

Types of service port

The customer decides the optimal type for his needs - whether rapid coupling or threaded.

MP11	MP12
D6	D8
D4	G 1/8"
D 1/4"	NPT 1/8"
M5	D6*
M7	M5*
	M7*
	D4*
	D 1/4*

* Special version 3-fold with 10 mm valves

Non-return valve for exhaust ports

Since functionality with non-return valves is required for certain applications, there are corresponding versions for this purpose.

- Without non-return valve
- Non-return valve in R
- Non-return valve in R+S
- For the module MP11, an integral pressure shut-off is additionally available (for a technical description, see the next page)

Storage temperature -20 °C to +60 °C

Basic pneumatic module with integral pressure shut-off

General description

For the basic pneumatic module MP 11 in the 2-way and 8-way versions, an integral pressure shut-off is available as an option. With this option, a faulty valve may be exchanged under pressure without relieving the pressure in the entire valve island or system. On exchange of the valve, the open cross section is reduced by a mechanism until only a very small leak remains.

Feature and limitations

Through the use of a pressure shut-off, some limitations arise in respect of the operating data of the overall system:

- The flow through valve types 6524/25 is reduced to ca. 60%.
- The operating pressure range possible lies between 5 and 7 bar.
- When using valves with external auxiliary control air, the pressure supply for the pilot valves is not shut off. Hence pressure shut-off may be used only in connection with valves with internal auxiliary control air within the limited pressure range.
- Pressure shut-off may be combined with the integral non-return valves.



NOTE

When using basic modules with pressure shut-off, take care that the pressure supply for the valve islands is executed with a suitably large volume (minimum hose diameter: 8/6 mm).

Procedure on exchange of a valve



ATTENTION!

- Only one valve may be removed at a time.
- On disassembly, note that in each case only the pressure channel is shut off! This means that any pressure applied to the service ports A or B is relieved on removal of the valve. Consequently, an actuator connected thereto will also become pressureless and a movement may be triggered.
- If the volume on the actuator side is large, install a device by which the service ports can be shut off to prevent movement of the actuator.

On removal of a valve, for functional reasons, a relatively large amount of air is initially blown off to ambient, since the pressure shut-off can close only when the required pressure difference is reached. Automatic shut-off, however, significantly reduces the air loss, so that only a small leak remains after closure.

- On assembly of the valve, make sure the seal is inserted correctly.
- Assemble the valve with the tightening torques stated in the operating instructions.
- On assembly of the valve, make sure the service ports are also pressurized in the corresponding rest position of the valve up to the time it is switched. Any actuator connected may execute a movement because of the pressurization.
- Make sure that such movements of the actuator do not cause damage or undesired actions in the system.



NOTE

Before exchanging a valve, we recommend bringing the system electrically into a safe basic condition.

Valves

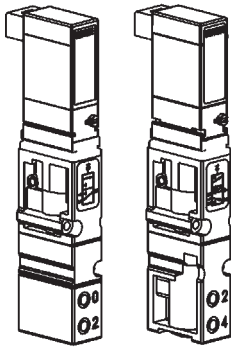

Type 6524 / 6525

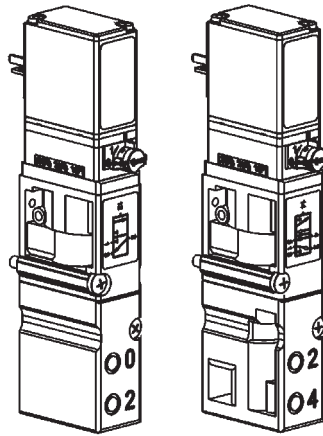

Type 6526 / 6527

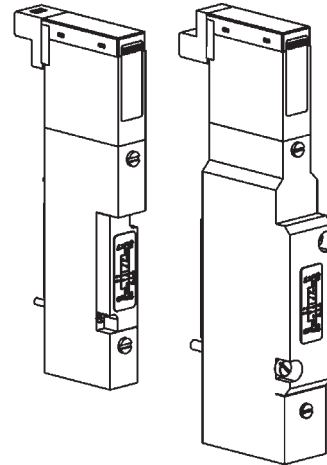

Type 0460 / 0461



EEX Approval II 3 G EEx nA II T4 for Type 6524 / 6525 and Type 6526 / 6527

General description

Automation systems are increasingly used in all areas where control duties are to be performed. The valves thereby form the interface between electronics and pneumatics.

The valves consist of a pilot solenoid valve and a pneumatic valve. Pilot valve and housing are clipped or screwed together. The working principle enables the switching of high pressures at low power consumption and with short switching times.

The valves are maintenance-free.

Variants

With AirLINE Type 8644, valves with the following circuit functions may be integrated:

Valve	Circuit function	Actuation	Width	Type
3/2-way	C (NC)	Internal control air	10	6524
	D (NO)			
	C (NC)	Auxiliary control air		
	D (NO)			
	C-vacuum (NC)			
3/2-way	C (NC)	Internal control air	16	6526
	D (NO)			
	C (NC)	Auxiliary control air		
	D (NO)			
	C-vacuum (NC)			
5/2-way	H	Internal control air	10	6525
		Auxiliary control air		
		Internal control air	16	6527
		Auxiliary control air		
5/3-way	L blocking middle position	internal control air	10	0460
	N exhausted		16	0461
	L blocking middle position			
	N exhausted			
5/2-way pulsed	H	internal control air	10	0460
			16	0461



NOTE

More detailed technical data can be found on the data sheets for the valves.

Valves with auxiliary control air

When valves with auxiliary control air are used, the exhaust air from the pilot valve escapes to ambient.

Valves with auxiliary control air cannot be combined on the valve island with valves with internal control air, since the connection X (see *System descriptions, Connector modules, pneumatic*) has a different configuration.

Storage temperature -20 °C to +60 °C

Limitations for use in Zone 2



ATTENTION!

For valve types 6526 and 6527, for use in Zone 2 with temperature class T4, the limitation (valve switch-off time) $T_{OFF} \geq 0.2 \text{ s}$ must be strictly complied with under the following conditions:

- with fast switch-on cycles (valve switch-on time $T_{ON} < 3 \text{ s}$)
- maximum ambient temperature of 55° C
- maximum permissible overvoltage $U_{nom} + 10 \%$

Valve switching time



If the valve is switched on for longer than 3 s, there are **no limitations** for the time until the next switch-on of the valve.

MAN 1000010120 EN Version: K Status: RL (released | freigegeben) printed: 23.04.2025

APPENDIX

EC-Declaration of Conformity	A2
Certificate of Conformity	A3

EC DECLARATION OF CONFORMITY

Bürkert Werke GmbH & Co. KG hereby declares as the manufacturer that these products comply with the requirements listed in the Guidelines of the Council for Harmonization of the Regulation of the Member States.

in respect of electromagnetic compatibility (89/336/EEC)

and are stipulated for devices and protective systems for intended use in potentially explosive zones (ATEX, 94/9EC).

For the assessment of the products in respect of **electromagnetic compatibility**, the following standards were applied:

EN 61000-6-4: 08/02	Basic engineering standard for interference emission; Part 2: Industrial domain
EN 61000-6-2: 08/02	Basic engineering standard for interference resistance; Part 2: Industrial domain

For the assessment of the products in respect of **ATEX**, the following standards were applied:

EN 50014: 02/00	Electrical equipment for potentially explosive zones, General regulations
EN 50021: 02/00	Electrical equipment for potentially explosive zones, Ignition protection type 2N2:

The EC Design Inspection Certificate PTB 02 ATEX 2048 was issued and the production audited (CE0102) by the

Physikalisch Technischen Bundesanstalt

Bundesallee 100

D-38116 Braunschweig

**NOTE**

|| Design Inspection Certificate PTB 02 ATEX 2048 is to be found in the Appendix.
|| For temperature classes and electrical data see "Technical data".

Physikalisch-Technische Bundesanstalt

Braunschweig und Berlin



Konformitätsaussage

- (1)
- (2) Geräte und Schutzsysteme zur bestimmungsgemäßen Verwendung in explosionsgefährdeten Bereichen - **Richtlinie 94/9/EG**
- (3) Prüfbescheinigungsnummer



PTB 02 ATEX 2048

- (4) Gerät: Ventilinsel Typ 8644
- (5) Hersteller: Bürkert GmbH & Co.KG.
- (6) Anschrift: Christian-Bürkert-Straße 13-17, 74653 Ingelfingen, Deutschland
- (7) Die Bauart dieses Gerätes sowie die verschiedenen zulässigen Ausführungen sind in der Anlage und den darin aufgeführten Unterlagen zu dieser Prüfbescheinigung festgelegt.
- (8) Die Physikalisch-Technische Bundesanstalt bescheinigt als benannte Stelle Nr. 0102 nach Artikel 9 der Richtlinie des Rates der Europäischen Gemeinschaften vom 23. März 1994 (94/9/EG) die Erfüllung der grundlegenden Sicherheits- und Gesundheitsanforderungen für die Konzeption und den Bau von Geräten und Schutzsystemen zur bestimmungsgemäßen Verwendung in explosionsgefährdeten Bereichen gemäß Anhang II der Richtlinie.
Die Ergebnisse der Prüfung sind in dem vertraulichen Prüfbericht PTB Ex 02-21358 festgehalten.
- (9) Die grundlegenden Sicherheits- und Gesundheitsanforderungen werden erfüllt durch Übereinstimmung mit
- EN 50021:1999**
- (10) Falls das Zeichen „X“ hinter der Bescheinigungsnummer steht, wird auf besondere Bedingungen für die sichere Anwendung des Gerätes in der Anlage zu dieser Bescheinigung hingewiesen.
- (11) Diese Konformitätsaussage bezieht sich nur auf Konzeption und Bau des festgelegten Gerätes gemäß Richtlinie 94/9/EG. Weitere Anforderungen dieser Richtlinie gelten für die Herstellung und das Inverkehrbringen dieses Gerätes.
- (12) Die Kennzeichnung des Gerätes muß die folgenden Angaben enthalten:



II 3 G EEx nA II T4

Zertifizierungsstelle Explosionsschutz
Im Auftrag

Braunschweig, 24. Juni 2002

gez. *Wilkens*

L.S.

Dipl.-Ing. R. Wilkens

Physikalisch-Technische Bundesanstalt

Braunschweig und Berlin

(13)

Anlage

(14)

Konformitätsaussage PTB 02 ATEX 2048

(15) Beschreibung des Gerätes

Diese Einheit ist ein elektrisches und pneumatisches Automatisierungssystem, das für den Einsatz im Schaltschrank oder Schaltkasten optimiert wurde. Sie dient zur Steuerung pneumatischer Anlagen mit dem vorgegebenen Feldbus-System. Sie besteht aus den elektrischen und pneumatischen Komponenten und kann je nach Bedarf erweitert werden. Alle elektrischen Daten sind auf 24 V DC ausgelegt und der Betreiber hat dafür Sorge zu tragen, dass die Bemessungsspannung durch Störungen um nicht mehr als 40 % überschritten wird.

Technische Daten

Bemessungsspannung	24 V DC
Nennleistung	1/0,25 W pro Magnetventil
Umgebungstemperaturbereich	0 °C bis 55 °C
Druckbereich	2,5 bar bis 7 bar
verwendete Magnetventiltypen	6524 und 6525
max. Anzahl der Magnetventile	64
Vorsteuerung für genannte Ventiltypen	6104

(16) Prüfbericht PTB Ex 02-21358

(17) Besondere Bedingungen

nicht zutreffend

(18) Grundlegende Sicherheits- und Gesundheitsanforderungen

durch vorgenannte Norm abgedeckt

Zertifizierungsstelle Explosionsschutz
Im Auftrag

Braunschweig, 24. Juni 2002

gez. *Wilkens*

L.S.

Dipl.-Ing. R. Wilkens

Contact addresses / Kontaktadressen**Germany / Deutschland / Allemange**

Bürkert Fluid Control System

Sales Centre

Chr.-Bürkert-Str. 13-17

D-74653 Ingelfingen

Tel. + 49 (0) 7940 - 10 91 111

Fax + 49 (0) 7940 - 10 91 448

E-mail: info@de.buerkert.com

International

Contact addresses can be found on the internet at:

Die Kontaktadressen finden Sie im Internet unter:

Les adresses se trouvent sur internet sous :

www.burkert.com Bürkert Company Locations

The smart choice
of Fluid Control Systems
www.buerkert.com

