

Type 8640

Modular valve island for pneumatics
with width per station 33 mm

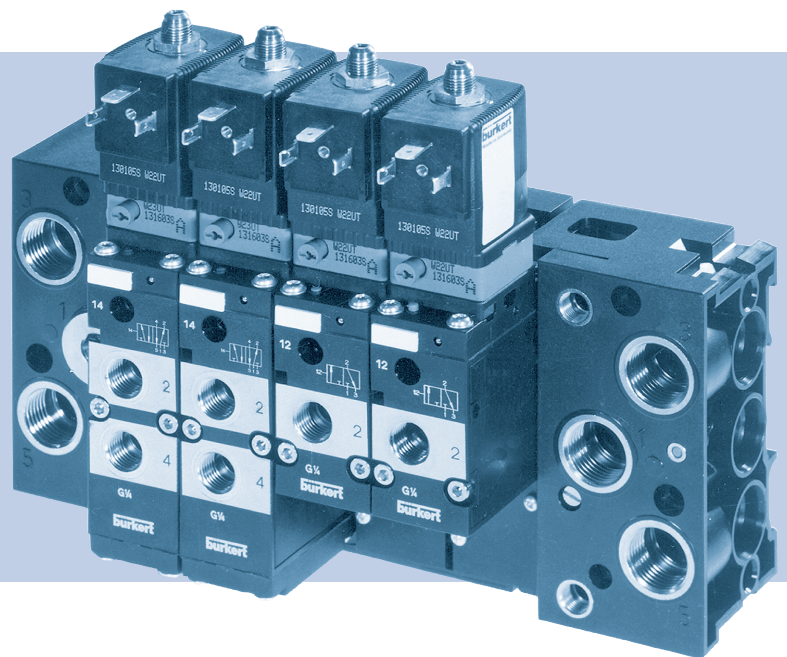

Operating Instructions

We reserve the right to make technical changes without notice.

© Bürkert Werke GmbH & Co. KG, 2025-2026

Operating Instructions 2602/19_EUen_00803150 / Original DE

1	OPERATING INSTRUCTIONS	4
1.1	Symbols	4
1.2	Definition of terms	4
2	INTENDED USE	5
3	BASIC SAFETY INSTRUCTIONS	6
4	GENERAL NOTES	8
4.1	Contact address.....	8
4.2	Information online	8
5	STRUCTURE AND DESCRIPTION	9
5.1	3/2 or 5/2-way valve	9
5.2	Description	11
5.3	Design of 5/3-way valve, 5/2-way pulse valve.....	11
5.4	Circuit functions	12
6	TECHNICAL DATA	13
6.1	Conformity	13
6.2	Standards.....	13
6.3	Operating conditions.....	13
6.4	Electrical data	14
6.5	Type label	14
7	INSTALLATION	15
7.1	Mounting pilot valve type 6014.....	16
7.2	Installing multiple blocks.....	17
7.3	Valve block installation.....	18
8	INSTALLATION	19
8.1	Pneumatic installation.....	19
8.2	Electrical installation	20
9	START-UP	21
10	MAINTENANCE, TROUBLESHOOTING	22
11	DISASSEMBLY	23
11.1	Valve block disassembly	23
11.2	Disassembling multi-blocks	23
11.3	Disassembling hose lines.....	23
12	RIGHT CONNECTION MODULE	24
13	PULSED OPERATION	25
14	TRANSPORTATION, STORAGE, DISPOSAL	26

1 OPERATING INSTRUCTIONS

The operating instructions describe the entire life cycle of the device. Keep these instructions ready to hand at the operation site.

Important safety information!

- ▶ Carefully read these instructions.
- ▶ Above all, observe the safety instructions, intended use and usage conditions.
- ▶ Persons who work on the device must read and understand these instructions.

1.1 Symbols



DANGER!

Warns of an immediate danger.

- ▶ Failure to observe will result in death or serious injuries.



WARNING!

Warns of a potential danger.

- ▶ Failure to observe these warnings may result in serious injuries or death.



CAUTION!

Warns of a potential hazard.

- ▶ Failure to observe may result in moderate or minor injuries.

NOTE!

Warns of damage.



Important tips and recommendations.

- ▶ Designates instructions to avoid danger.
- Highlights a procedure which you must carry out.

1.2 Definition of terms

Term	Definition for these instructions
Device	Valve island type 8640

2 INTENDED USE

The valve island type 8640 with valves types 6518 and 6519 is designed to control neutral media and compressed air.

- ▶ The device must only be used for its intended purpose. Non-intended use of the device may be dangerous to people, nearby equipment and the environment.
- ▶ Use the device only in conjunction with third-party devices and components recommended or approved by Bürkert.
- ▶ Prerequisites for safe and trouble-free operation include correct transportation, correct storage, installation, start-up, operation and maintenance.
- ▶ Observe the permissible data, operating conditions and conditions of use of the respective devices or products. These specifications can be found in the contract documents, the operating instructions and on the type label.
- ▶ With a properly connected and mounted cable plug, e.g. Bürkert type 2518, the device fulfils degree of protection IP65 according to DIN EN 60529 / IEC 60529.

3 BASIC SAFETY INSTRUCTIONS

These safety instructions do not take into account any coincidences or events occurring during installation, operation and maintenance. The operator is responsible for observing the location-specific safety regulations, also with reference to personnel.



Risk of injury due to high pressure and escaping medium.

- ▶ Switch off the pressure before working on the device or system. Vent or drain the pipes.

Risk of injury due to electric shock.

- ▶ Switch off voltage before working on the device or system. Secure against reactivation.
- ▶ Observe any applicable accident prevention and safety regulations for electrical devices.

Risk of injury from quickly accelerating device parts and unconnected compressed air hoses flapping around.

- ▶ Before applying pressure to the valve, check all hose connections and fittings for tight, secure fit.

Risk of burns or fire from hot device surfaces due to longer duty cycles.

- ▶ Only touch the device when wearing protective gloves.
- ▶ Keep the device away from highly flammable substances and media.

Risk of injury from malfunctioning valves with alternating current (AC)

A seized core causes the coil to overheat, which leads to functional failure.

- ▶ Monitor the working process for proper function.

General hazardous situations.

To prevent injuries, observe the following:

- ▶ Observe the general rules of technology.
- ▶ In the potentially explosive atmosphere, only use devices that are approved for this purpose. These devices are identified by a separate “Ex” type label. Before use, note the information on the separate Ex type label and the Ex additional instructions or the separate Ex operating Instructions.
- ▶ Use the device only when it is in perfect condition and in accordance with the operating instructions.
- ▶ Secure the device or system to prevent unintentional activation.
- ▶ After an interruption in the power supply, ensure that the process is restarted in a controlled manner.
- ▶ Do not modify the device.
- ▶ Do not mechanically load the device.
- ▶ Only trained technicians may perform installation and maintenance work.
- ▶ Install the device according to the regulations applicable in the respective country.

NOTE!

Electrostatically sensitive components and assemblies.

The device contains electronic components that are susceptible to the effects of electrostatic discharging (ESD). Components that come into contact with electrostatically charged persons or objects are at risk. In the worst case scenario, these components will be destroyed immediately or fail after start-up.

- ▶ Meet the requirements specified by EN 61340-5-1 to minimise or avoid the possibility of damage caused by sudden electrostatic discharge.
- ▶ Do not touch electronic components when the supply voltage is connected.

4 GENERAL NOTES

4.1 Contact address

Germany

Bürkert Fluid Control Systems
Sales Centre
Christian-Bürkert-Str. 13-17
D-74653 Ingelfingen
Tel. +49 (0) 7940 - 10-91 111
Fax +49 (0) 7940 - 10-91 448
Email: info@burkert.com

International

Contact addresses can be found on the final pages of the printed operating instructions.
They are also available online at: country.burkert.com.

4.2 Information online

Operating instructions and data sheets for Bürkert products can be found on the Internet at:
country.burkert.com.

5 STRUCTURE AND DESCRIPTION

5.1 3/2 or 5/2-way valve

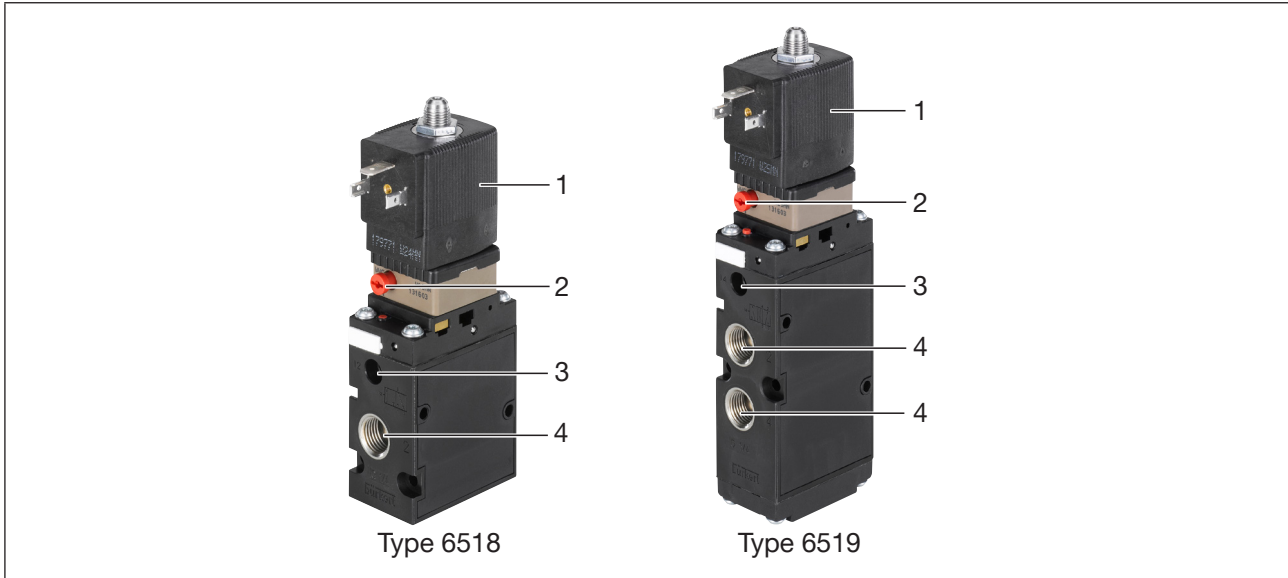

Figure 1: Valve assembly 3/2 or 5/2-way valve

Item	Designation	Item	Designation
1	Pilot control	2	Manual override (see Chapter “5.1.2 Manual override”)
3	Pilot pressure port	4	Working port

5.1.1 Compatible pilot controls

Solenoid	Cable plug	Design	Figure
AC08	2507	B	
	2516	C	
AC10	2518	A	

5.1.2 Manual override

→ To operate the valve manually, press the manual override and turn it 90° clockwise (until it stops). The manual override is locked and does not reset automatically.

→ Only operate the manual override when the power is off.

5.1.3 Connections

The connections are marked with numbers for better assignment.

Connection number	Designation
1	Pressure port
2 and 4	Working port
3 and 5	Exhaust port
12 and 14	Pilot pressure port

5.1.4 Tightening torques for port connections

Observe the following tightening torques when screwing into the port connections. The specified tightening torque may vary depending on the sealing system.

Port size	Marking/function	Recommended tightening torque [Nm]	Maximum tightening torque [Nm]
G1/2	P, R/S connection	7...9	50
NPT1/2			
G1/4	A/B valve outlets	4...7	20
NPT1/4			
G1/8	Auxiliary pilot air pneumatic module	3...6	10
NPT1/8			
M5	Auxiliary pilot air valves	1...1.2	3

5.2 Description

The valves consist of:

- 3/2-way pilot valve (type 6014) with different electrical connection variants.

Pilot valve coil can be locked in 4 x 90° steps, in between it can be positioned as desired around the core guide tube.

- Valve body with diaphragm and seat seals (3/2 and 5/2-way valve) or slide (5/3-way valve).
- Working ports 2 (B) / 4 (A) with G1/4 internal thread.
- Supply and exhaust port 1 (P) / 3 (R) / 5 (S) with G1/4 internal thread.

The valves can be mounted on the modular, pneumatic type MP07 base rails to form valve blocks. Any installation position, preferably with solenoid actuator on top.



The cable plug is used to control DC and AC coils with power ratings up to 7 W without external power supply.

5.3 Design of 5/3-way valve, 5/2-way pulse valve

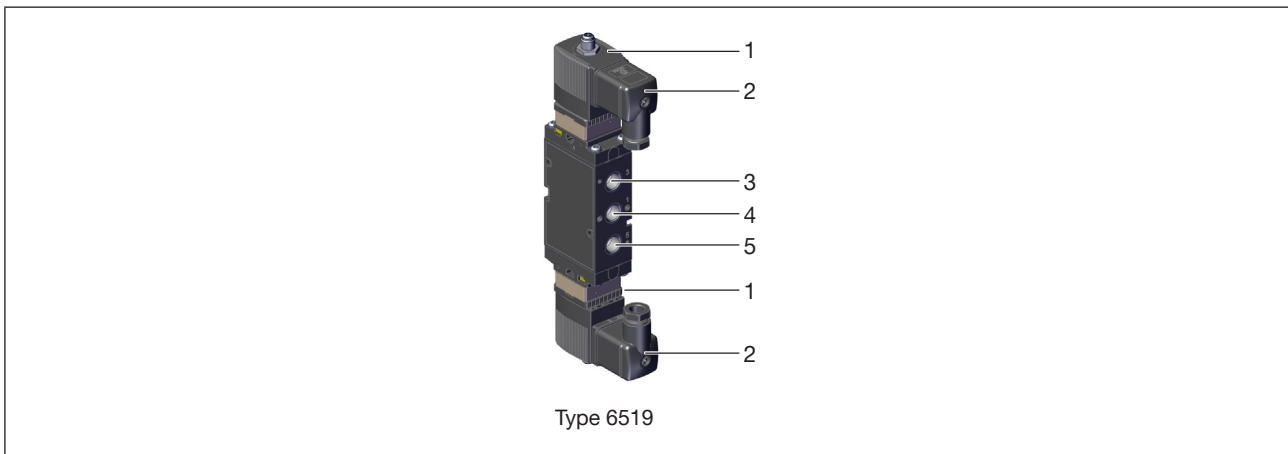

Figure 2: Design of 5/3-way valve (slide valve with metal body), 5/2-way pulse valve

Item	Designation	Item	Designation
1	Pilot valve	2	Cable plug
3	Exhaust port 3	4	Pressure port 1
5	Exhaust port 5		

5.4 Circuit functions

	<p>C, 3/2-way valve (*for vacuum¹⁾), with auxiliary pilot air</p> <p>In idle position, pressure port 1 (P/NC) closed, working port 2 (A/OUT) open after port 3 (R/NO).</p>
<p>*Vacuum, with auxiliary pilot air</p>	
	<p>D, 3/2-way valve</p> <p>In idle position, pressure port 1 (P/NO) open after working port 2 (B/OUT), port 3 (R/NC) closed.</p>
	<p>H, 5/2-way valve</p> <p>In idle position pressure port 1 (P) after working port 2 (A) open, working port 4 (B) after port 5 (S) open, port 3 (R) closed.</p>
	<p>Z, 5/2-way valve</p> <p>Pulse variant (2 coils)</p>
	<p>L, 5/3-way valve</p> <p>In the centre position, all connections are closed. Pressure port at 1. Working ports at 4 and 2. Vent the working ports after 5 or 3.</p>
	<p>N, 5/3-way valve</p> <p>In the middle position, pressure port 1 (P) closed, both working ports 2 (A) and 4 (B) open after outlet 3 (R) or 5 (S).</p>

MAN 1000488160 EN Version: F Status: RL (released | freigegeben) printed: 14.02.2026

¹⁾ The vacuum generator must be connected to port 1.

6 TECHNICAL DATA

6.1 Conformity

The device conforms to EU directives as per the EU Declaration of Conformity.

6.2 Standards

The applied standards which are used to demonstrate compliance with the EU Directives are listed in the EU-Type Examination Certificate and/or the EU Declaration of Conformity.

6.3 Operating conditions

NOTE!

Pilot pressure for pneumatic control depends on the pressure of the flow medium; it must be between 2...8 bar (at least 70% of operating pressure).

NOTE!

Pressure difference between port 1 and 3/5 at least 2 bar

Ambient temperature	-10 ... +55 °C
Medium temperature	-10 ... +50 °C
Medium	<ul style="list-style-type: none"> • Filtered compressed air, particle size max. 10 µm, preferably unlubricated (operation with lubricated air is possible) • neutral gases
Operating pressure range	2 ... 10 bar (2 ... 16 bar variable Code RN16)

6.3.1 Materials

Sealing materials depend on the body materials:

Body material	PA	AL
Seal material	NBR, PUR	NBR, FKM

6.4 Electrical data

Electrical connection	Cable plug type 2516 or 2518 on the plug contacts of the coil (torque for fastening: 0.5 to 0.6 Nm).
Additional electrical connection options	Type 6014 or 8640
Voltage tolerance	±10 %
Degree of protection	IP65 Only in connection with cable plug
Cable plug	can be mounted offset by 4 x 90° for the cable outlet selected.

NOTE!

Damage to the appliance when screwing the cable plug.

- Make sure that the flat seal is seated properly.

6.5 Type label

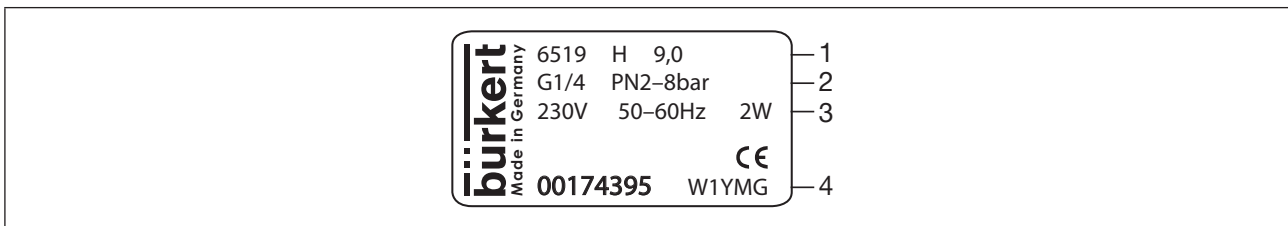

Figure 3: Example of type plate of pilot-operated solenoid valve type 6519

Item	Text	Designation
1	6519	Type
	H	Circuit function
	9.0	Orifice
2	G1/4	Connection type
	PN 2-8 bar	Operating pressure range
3	230V	Voltage
	50-60Hz	Frequency
	2W	Capacity
4	00174395	Article number
	W1YMG	Manufacture code (encrypted)

7 INSTALLATION



WARNING!

Risk of injury due to improper installation.

- ▶ Only trained technicians may perform installation work.
- ▶ Perform installation work using suitable tools only.

Risk of injury from quickly accelerating device parts and unconnected compressed air hoses flapping around.

- ▶ Before applying pressure to the valve, check all hose connections and fittings for tight, secure fit.

Risk of injury due to unintentional activation of the system and uncontrolled restart.

- ▶ Secure the system against unintentional activation.
- ▶ Following installation, ensure a controlled restart.

Prior to installation

- Clean the pipes.
- If necessary, attach dirt trap upstream.
- Do not use the coil as a lever when screwing in the connections.

7.1 Mounting pilot valve

WARNING!

Risk of injury due to leaking valve.

- ▶ Make sure that the O-rings/seals are correctly seated in the valve.

Overheating, risk of fire.

Without a pre-installed valve, connecting the coil will cause overheating and destroy the coil.

- ▶ Only connect the coil after the valve has been installed.

Danger of electric shock if the coil is installed incorrectly.

- ▶ When installing, make sure that the coil is firmly seated on the housing lid so the protective conductor connection of the coil is connected to the valve body.

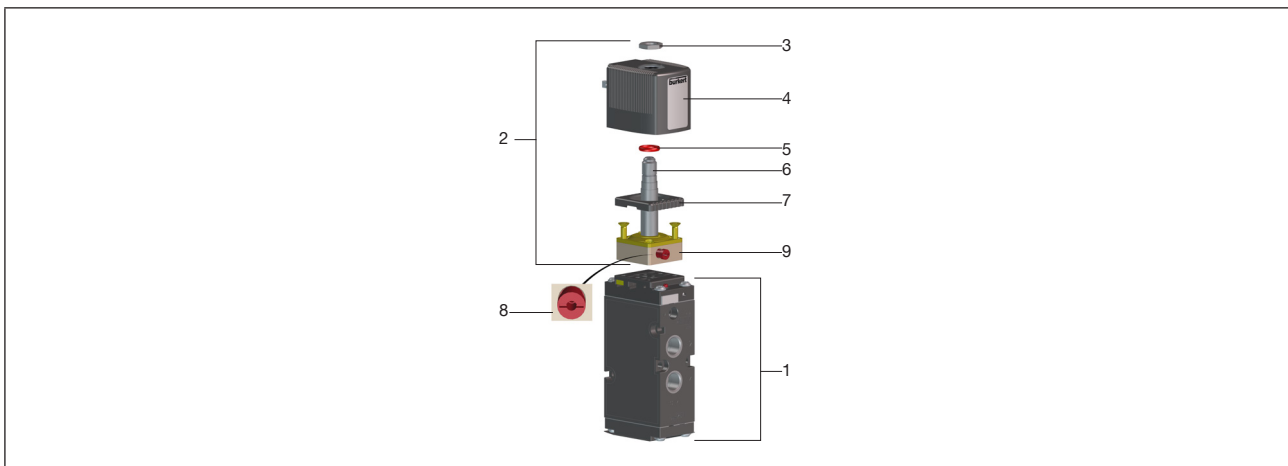

Figure 4: Mounting pilot valve

Item	Designation	Item	Designation
1	Pneumatic valve	2	Pilot valve
3	Nut	4	Solenoid
5	O-ring	6	Core guide tube
7	Housing lid	8	Manual override
9	Body		

NOTE!

Do not use the coil as a lever arm when screwing it in.

- Screw the body of the pilot valve onto the pneumatic valve.
Observe the maximum tightening torque of 1.5 Nm.
- Place the lid on the body.
- Fit the O-ring onto the core guide tube.
- Position the coil onto the core guide tube.
The coil can be rotated 4 x 90° (with block installation only 2 x 180°).
- Fasten the coil nut with an open-end wrench.
Observe a maximum tightening torque of 5 Nm.

7.2 Installing multiple blocks

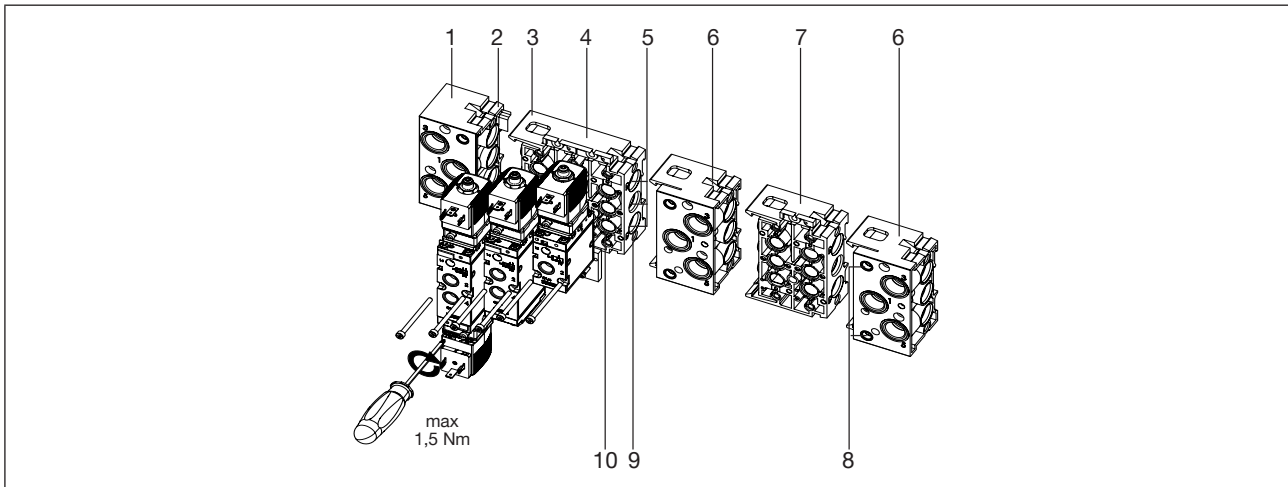

Figure 5: Example of a multi-block with type 6519 valves

Item	Designation	Item	Designation
1	Left connection module	2	Latch tab
3	Latch hook	4	Base modules 3-fold
5	Supply channel 1(P) Exhaust channels 3(R), 5(S)	6	Right connection module (Intermediate supply)
7	Base modules 2-fold	8	Venting the pilot control
9	O-ring	10	Profile seal

- Begin installation with connection module on the left (see “Figure 5”)
- Check modules for complete installation. 1 O-ring per connection.
- Lightly oil or grease all O-rings before engaging.
- Engage the latch hooks of the module to be attached in the latch grooves of the preceding module. Make sure that the O-rings are properly seated.
- Ensure the profile seals are correctly seated on the base module.

! Crushed O-rings and profile seals lead to leaky blocks.

- Fasten each valve to the base module with 2 M4 screws. Recommended tightening torque 0.7 ±0,1 Nm.

7.3 Valve block installation

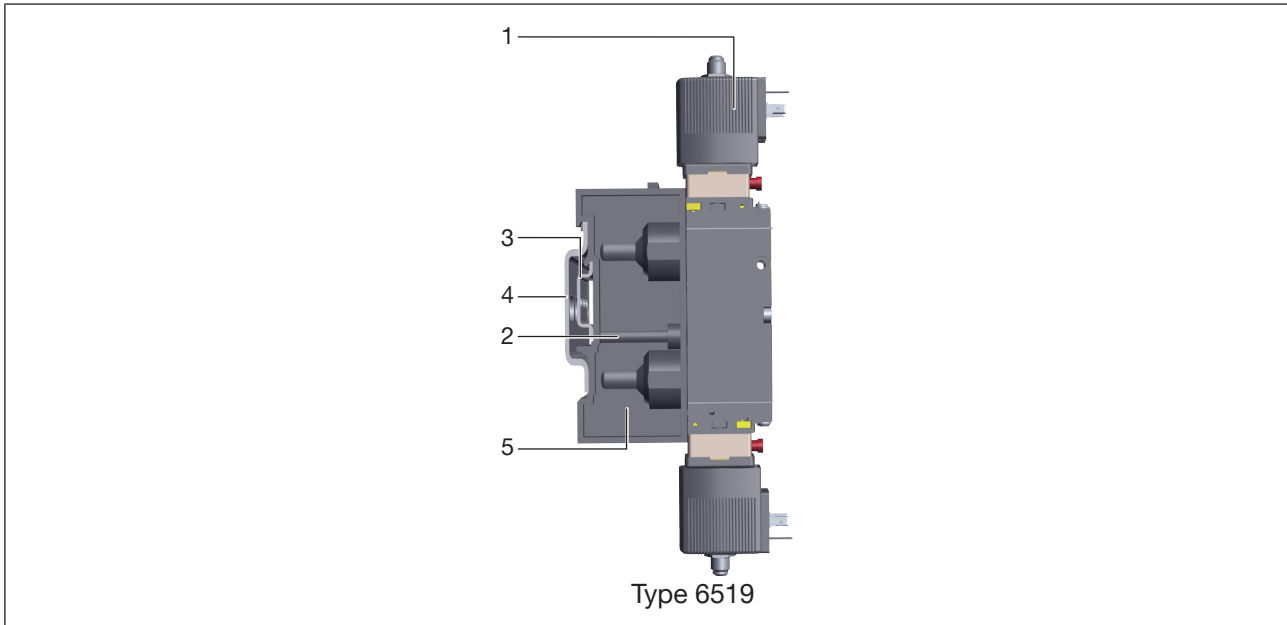

Figure 6: Mounting the valve block

Item	Designation	Item	Designation
1	Electrical connection can be rotated 180°	2	Wall mount
3	Standard rail 35 x 15 DIN 50022	4	Standard rail 75 x 25 DIN 50023
5	Connection module		

7.3.1 Standard rail installation

- Hook the valve block with the upper groove into the standard rail.
- Snap the lower clamping pieces into the standard rail.
- Tighten the screws on the clamping pieces.

Standard rail

- Standard rail 35 x 15 DIN 50022 (standard)
- Standard rail 75 x 25 DIN 50023



When using the standard rail 75 x 25 DIN 50023, reposition the pre-installed screws accordingly with clamping pieces and springs.

7.3.2 Wall installation

- Fasten the valve block directly to the wall with M5 screws.

8 INSTALLATION

WARNING!

Risk of injury due to improper installation

- ▶ Only trained technicians may perform installation work.
- ▶ Only carry out installations with suitable tools.

Risk of injury due to unintentional activation of the system and uncontrolled restart.

- ▶ Secure the system against unintentional activation.
- ▶ Following installation, ensure a controlled restart.

8.1 Pneumatic installation

DANGER!

Risk of injury due to high pressure and escaping medium.

- ▶ Switch off the pressure before working on the device or system.
Vent or drain the pipes.

DANGER!

Risk of injury from quickly accelerating device parts and unconnected compressed air hoses flapping around.

- ▶ Before applying pressure to the valve, check all hose connections and fittings for tight, secure fit.

Installation position of the valves

- any, preferably solenoid actuator on top

Before connection

- Check the hose lines for contamination and clean them.
- If necessary, install dirt traps upstream of the valve inlet ($\leq 500 \mu\text{m}$).

Pneumatic connection

NOTE!

Note the assignment of the connections (see Chapter “5.1.3 Connections”)

- Push the hose lines into the push-in connections of the solenoid valves until they come to a stop.
- Use PTFE tape or elastomer seal for sealing.
- Align hose lines
- Connect the supply and working lines to the valve block.

Requirements for hose lines

- Minimum hardness 40 Shore D (according to DIN 53505 or ISO 868).
- Outer diameter according to DIN 73378 (maximum permissible deviation $\pm 0.1 \text{ mm}$ from nominal dimension).
- Burr-free, cut off at right angles and undamaged on the outer diameter surface.

8.2 Electrical installation

DANGER!

Risk of injury due to electric shock.

- ▶ Switch off voltage before working on the device or system. Secure against reactivation.
- ▶ Observe any applicable accident prevention and safety regulations for electrical devices.

If there is no protective conductor contact between the coil and the housing, there is a risk of electric shock!

- ▶ Always connect the protective conductor.
- ▶ Check electrical continuity between coil and body.

→ Make the electrical connections to the pilot valves while observing the data on the type plate.

8.2.1 Electrical installation of cable plugs

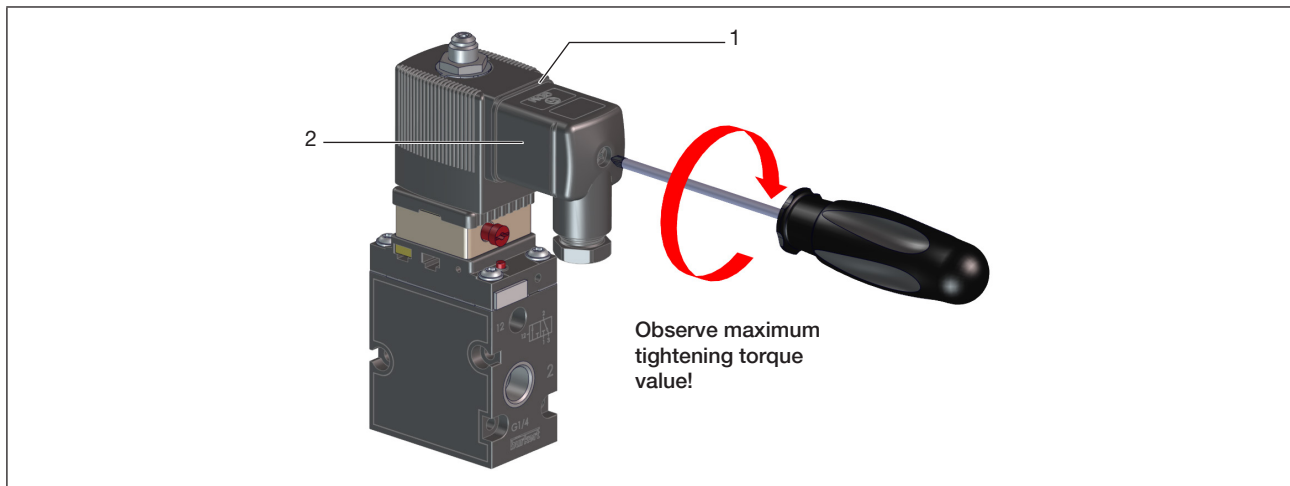

Figure 7: Installation of cable plug

Item	Designation	Item	Designation
1	Seal	2	Approved cable plug e.g. type 2518 or other according to DIN ISO 175301-803 Form A

→ Screw on the cable plug (see data sheet for approved types), observing the maximum tightening torque of 0.5 to 0.6 Nm.

→ Check that the seal is correctly fitted.

→ Connect the protective conductor and check electrical continuity between coil and body (see “Table 1”).

NOTE!

If the screw is pointing upwards when installed, insert a seal made of a material compatible with the process under the screw head.

Resistance	Test voltage	Test current
Maximum 0.1 Ω	12 V	1 A

Table 1: Protective conductor function test values

9 START-UP



WARNING!

Risk of injury due to improper operation.

- ▶ Prior to start-up, it must be ensured that the operating personnel are familiar with and fully understand the contents of the operating instructions.
- ▶ Only authorised technicians may start up the device or system.

→ Check connections, voltage and operating pressure.

→ Observe data on the type label.

→ Check the correct assignment of connections 1 and 3 or 5. Do not mix them up under any circumstances.

→ For electrical operation, unlock the manual override.

10 MAINTENANCE, TROUBLESHOOTING

! WARNING!

Risk of injury if maintenance work is not carried out correctly.

- ▶ Only trained technicians may perform maintenance work.
- ▶ Perform maintenance work using suitable tools only.

Risk of injury due to unintentional activation of the system and uncontrolled restart.

- ▶ Secure the system against unintentional activation.
- ▶ Ensure a controlled restart after maintenance is completed.

Fault	Possible cause	Remedy
Valves do not switch	No operating voltage or operating voltage too low	Check electrical connection Ensure operating voltage according to type label.
	Manual override not in zero position	Bring manual override to zero position.
	Pressure supply insufficient or not available	Set up large-volume pressure supply (also for upstream devices such as pressure controllers, maintenance units, on/off valves, etc.) Minimum operating pressure ≥ 2 bar
Valves switch with a delay or blow off at the exhaust ports	Pressure supply insufficient or not available	Set up large-volume pressure supply (also for upstream devices such as pressure controllers, maintenance units, on/off valves, etc.) Minimum operating pressure ≥ 2 bar
	Valves are not in the home position (de-energised) during pressure build-up	Apply pressure to the valve block before the valves are switched.
	Insufficient ventilation of the exhaust air ducts due to too small or dirty silencers (back pressure)	Use suitably sized silencers or expansion vessels. Clean the dirty silencers.
	Impurities or foreign matter in the pilot or pneumatic valve	Apply pulsed pressure to the exhaust air ducts to blow out the impurities. Install a new pilot or pneumatic valve.
Leaky valve blocks	Missing or crushed O-rings between the modules	Identify leak or missing seals
	Missing or incorrectly positioned flat seals between valve and base plate	Insert missing seals or replace damaged seals

MAN 1000488160 EN Version: F Status: RL (released | freigegeben) printed: 14.02.2026

11 DISASSEMBLY

WARNING!

Risk of injury due to high pressure and escaping medium.

- ▶ Switch off the pressure before working on the device or system.
Vent or drain the pipes.

Risk of injury due to electric shock.

- ▶ Switch off voltage before working on the device or system. Secure against reactivation.
- ▶ Observe any applicable accident prevention and safety regulations for electrical devices.

WARNING!

Risk of injury due to improper disassembly.

- ▶ Only trained specialist personnel may carry out the disassembly.
- ▶ Perform disassembly work using suitable tools only.

Risk of injury from dangerous fluids.

- ▶ Before loosening lines or valves, flush out hazardous media, depressurise and drain the lines.

11.1 Valve block disassembly

- Loosen the clamping screws (approx. 4 turns).
- Remove the block upwards from the standard rail.

11.2 Disassembling multi-blocks

- Use the screwdriver to disengage the upper latch hook from the disassembly groove on the front side.
- Remove the sub-block/module from the side.

11.3 Disassembling hose lines

- To release the lines, push in the thrust collar and pull out the hose line.

12 RIGHT CONNECTION MODULE

Other application options:

- Connection modules on the right can be used in special applications as sub-modules to build up several operating pressure stages in one block.
- Makes additional feed possible for larger valve blocks (see chapter [“Figure 6: Mounting the valve block”](#)).

NOTE!

If necessary, pierce the lateral predetermined breaking points of connections 1, 3 and 5, and those of the upper pilot vent.

13 PULSED OPERATION

Pulse-controlled solenoid valves work with two coils that are switched alternately.

NOTE!

Observe pulse data on the type label. Avoid simultaneous pulsing of both coils.



Valves can be reversed with the manual override.

14 TRANSPORTATION, STORAGE, DISPOSAL

NOTE!

Damage in transit due to inadequately protected devices.

- ▶ Protect the device against moisture and dirt in shock-resistant packaging during transportation.
- ▶ Observe permitted storage temperature.
- ▶ Protect the electrical interfaces of the coil and the pneumatic connections from damage by placing protective caps on them.

Incorrect storage may damage the device.

- ▶ Store the device in a dry and dust-free location.
- ▶ Storage temperature $-40 \dots +80 \text{ }^{\circ}\text{C}$.

Environmentally friendly disposal



- ▶ Follow national regulations regarding disposal and the environment.
- ▶ Collect electrical and electronic devices separately and dispose of them as special waste.

Further information country.burkert.com.