

Type 8640

Modular valve island for pneumatics
with width per station 19 mm

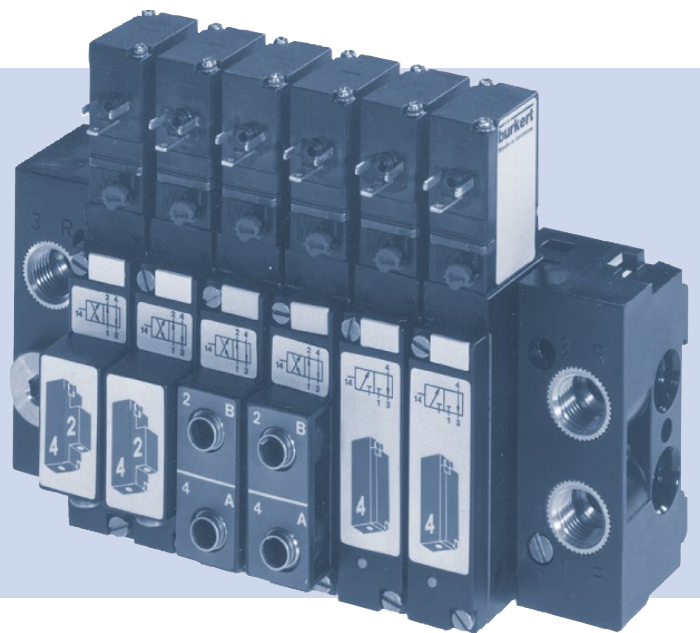

Operating Instructions

We reserve the right to make technical changes without notice.

© Bürkert Werke GmbH & Co. KG, 2025

Operating Instructions 2501/12_EUen_00803136 / Original DE

1	OPERATING INSTRUCTIONS.....	4
1.1	Symbols	4
1.2	Definition of terms	4
2	INTENDED USE	5
3	BASIC SAFETY INSTRUCTIONS.....	6
4	GENERAL NOTES.....	7
4.1	Contact address.....	7
4.2	Information online	7
5	STRUCTURE AND DESCRIPTION	8
5.1	Design	8
5.2	Description	10
5.3	Circuit functions	10
5.4	Conversion of 4/2 to a 3/2-way valve	11
6	TECHNICAL DATA	12
6.1	Standards and directives	12
6.2	Operating conditions.....	12
6.3	Electrical data	12
6.4	Type label	13
7	INSTALLATION.....	14
7.1	Rotating the solenoid	15
7.2	Installing multiple blocks.....	16
7.3	Valve block installation.....	17
7.4	Single valve installation.....	18
8	INSTALLATION.....	19
8.1	Pneumatic installation.....	19
8.2	Recommended action for push-in connectors	20
8.3	Electrical installation	22
9	START-UP	24
10	MAINTENANCE, TROUBLESHOOTING.....	25
11	DISASSEMBLY.....	26
11.1	Valve block disassembly	26
11.2	Disassembling multi-blocks	26
11.3	Disassembling hose lines.....	26
12	RIGHT CONNECTION MODULE	27
13	TRANSPORTATION, STORAGE, DISPOSAL.....	28

1 OPERATING INSTRUCTIONS

The operating instructions describe the entire life cycle of the device. Keep these instructions ready to hand at the operation site.

Important safety information!

- ▶ Carefully read these instructions.
- ▶ Above all, observe the safety instructions, intended use and usage conditions.
- ▶ Persons who work on the device must read and understand these instructions.

1.1 Symbols



DANGER!

Warns of an immediate danger.

- ▶ Failure to observe will result in death or serious injuries.



WARNING!

Warns of a potential danger.

- ▶ Failure to observe these warnings may result in serious injuries or death.



CAUTION!

Warns of a potential hazard.

- ▶ Failure to observe may result in moderate or minor injuries.

NOTE!

Warns of damage.



Important tips and recommendations.

- ▶ Designates instructions to avoid danger.
- Highlights a procedure which you must carry out.

1.2 Definition of terms

Term	Definition for these instructions
Device	Valve island type 8640

2 INTENDED USE

The valve island type 8640 with valves of type 5470 is designed to control neutral media and compressed air.

- ▶ The device must only be used for its intended purpose. Non-intended use of the device may be dangerous to people, nearby equipment and the environment.
- ▶ Use the device only in conjunction with third-party devices and components recommended or approved by Bürkert.
- ▶ Prerequisites for safe and trouble-free operation include correct transportation, correct storage, installation, start-up, operation and maintenance.
- ▶ Observe the permissible data, operating conditions and conditions of use of the respective devices or products. These specifications can be found in the contract documents, the operating instructions and on the type label.
- ▶ With a properly connected and assembled cable plug, e.g. type 2516, the device complies with degree of protection IP65 in accordance with DIN EN 60529 / IEC 60529.

3 BASIC SAFETY INSTRUCTIONS

These safety instructions do not take into account any coincidences or events occurring during installation, operation and maintenance. The operator is responsible for observing the location-specific safety regulations, also with reference to personnel.

Risk of injury due to high pressure and escaping medium.

- ▶ Switch off the pressure before working on the device or system. Vent or drain the pipes.

Risk of injury due to electric shock.

- ▶ Switch off voltage before working on the device or system. Secure against reactivation.
- ▶ Observe any applicable accident prevention and safety regulations for electrical devices.

Risk of injury from quickly accelerating device parts and unconnected compressed air hoses flapping around.

- ▶ Before applying pressure to the valve, check all hose connections and fittings for tight, secure fit.

Risk of burns or fire from hot device surfaces due to longer duty cycles.

- ▶ Only touch the device when wearing protective gloves.
- ▶ Keep the device away from highly flammable substances and media.

General hazardous situations.

To prevent injuries, observe the following:

- ▶ Observe the general rules of technology.
- ▶ In the potentially explosive atmosphere, only use devices that are approved for this purpose. These devices are identified by a separate “Ex” type label. Before use, note the information on the separate Ex type label and the Ex additional instructions or the separate Ex operating Instructions.
- ▶ Approvals such as Ex, UL, UR, CSA, DVGW etc. are marked on the type label or by a special sticker.
- ▶ Use the device only when it is in perfect condition and in accordance with the operating instructions.
- ▶ Secure the device or system to prevent unintentional activation.
- ▶ After an interruption in the electrical or pneumatic supply, ensure that the process is restarted in a controlled manner.
- ▶ Do not modify the device.
- ▶ Do not mechanically load the device.
- ▶ Only trained technicians may perform installation and maintenance work.
- ▶ Install the device according to the regulations applicable in the respective country.

NOTE!

Electrostatically sensitive components and assemblies.

The device contains electronic components that are susceptible to the effects of electrostatic discharging (ESD). Components that come into contact with electrostatically charged persons or objects are at risk. In the worst case scenario, these components will be destroyed immediately or fail after start-up.

- ▶ Meet the requirements specified by EN 61340-5-1 to minimise or avoid the possibility of damage caused by sudden electrostatic discharge.
- ▶ Do not touch electronic components when the supply voltage is connected.

4 GENERAL NOTES

4.1 Contact address

Germany

Bürkert Fluid Control Systems
Sales Centre
Christian-Bürkert-Str. 13-17
D-74653 Ingelfingen
Tel. +49 (0) 7940 - 10-91 111
Fax +49 (0) 7940 - 10-91 448
Email: info@burkert.com

International

Contact addresses can be found on the final pages of the printed operating instructions.
They are also available online at: country.burkert.com.

4.2 Information online

Operating instructions and data sheets for Bürkert products can be found on the Internet at:
country.burkert.com.

5 STRUCTURE AND DESCRIPTION

5.1 Design

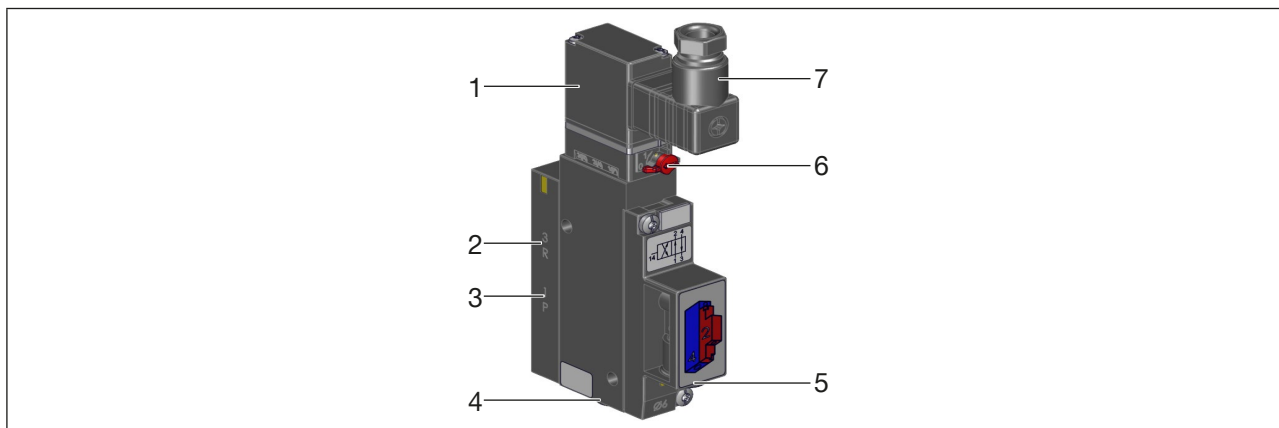

Figure 1: Structure of solenoid valve type 5470

Item	Designation
1	Pilot valve Type 6106
2	Exhaust port 3
3	Pressure port 1
4	Working port 4
5	Working port 2
6	Manual override
7	Cable plug Type 2506

5.1.1 Manual override

- To operate the valve manually, press the manual override and turn it 90° clockwise (until it stops). The manual override is locked and does not reset automatically.
- Only operate the manual override when the power is off.

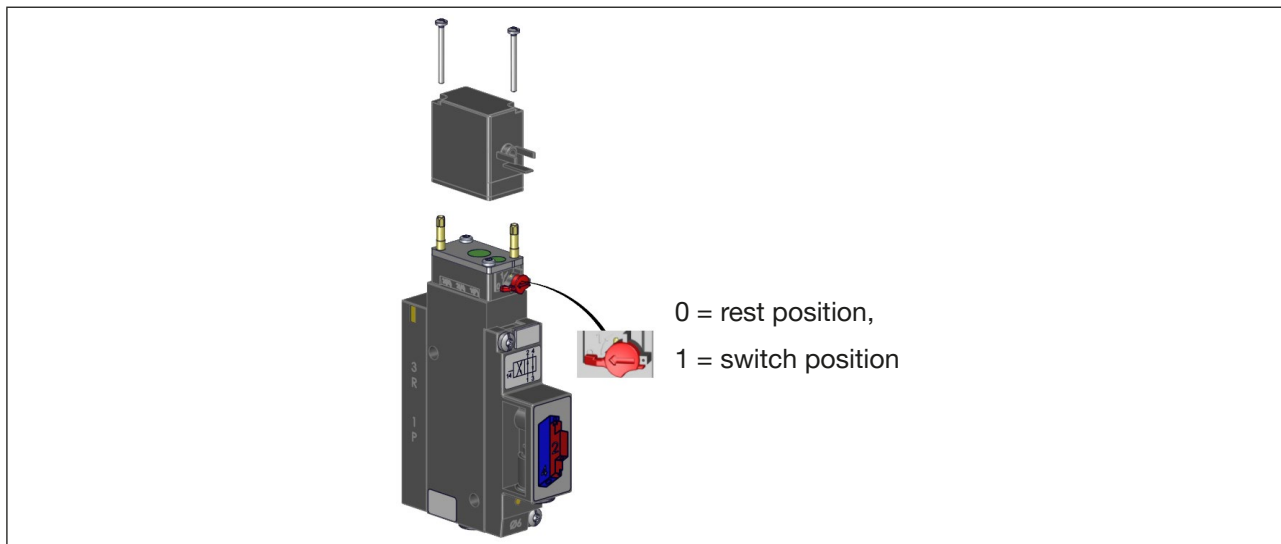

Figure 2: Manual override of solenoid valve type 5470

5.1.2 Connections

The connections are marked with numbers for better assignment.

Connection number	Designation
1	Pressure port
2 and 4	Working port
3	Exhaust port

5.2 Description

The valves consist of:

- 3/2-way pilot valve (Type 6106) with different electrical connection variants.
- Valve body with diaphragm, seat seals and A/B connection plates.
- Working ports 2 (B) / 4 (A) as well as supply connection and exhaust port 1 (P) / 3 (R) optionally with internal thread, plug-in coupling or pointed hose nipples.
- Manual override for manual activation of the valve.

The valves can be mounted on the modular, pneumatic type MP05 base rails to form valve blocks. Any installation position, preferably with solenoid actuator on top.



The cable plug type 2516 is used to control DC and AC coils with power $\leq 5\text{ W}$ without external power supply.

5.3 Circuit functions

	<p>C, 3/2-way valve</p> <p>In rest position, pressure port 1 (P/NC) closed, working port 2 (A/OUT) open after port 3 (R/NO).</p>
	<p>D, 3/2-way valve</p> <p>In rest position, pressure port 1 (P/NO) open after working port 2 (B/OUT), port 3 (R/NC) closed.</p>
	<p>G, 4/2-way valve</p> <p>In rest position, pressure port 1 (P) open after working port 2 (A), working port 4 (B) open after port 3 (R).</p>

5.4 Conversion of 4/2 to a 3/2-way valve

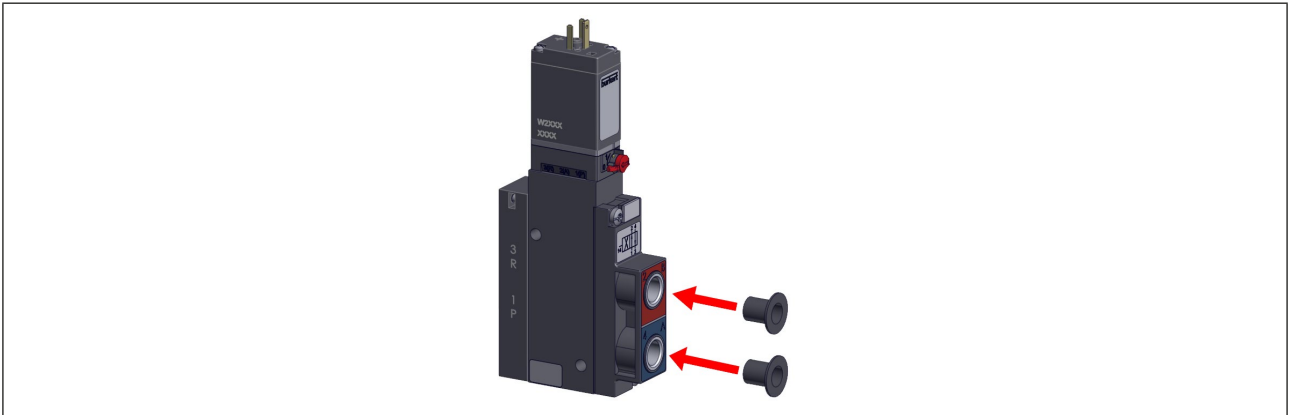

Figure 3: Conversion of 4/2 to a 3/2-way valve

→ To convert the 4/2-way valve to a 3/2-way valve, depending on the desired circuit function, close port 2 or port 4 with a stopper.

Port 2	Port 4	Circuit function	
closed	open	C	
open	closed	D	

6 TECHNICAL DATA

6.1 Standards and directives

The device complies with the valid EU harmonisation legislation.

The harmonised standards that have been applied for the conformity assessment procedure are listed in the current version of the EU Declaration of Conformity.

6.2 Operating conditions

NOTE!

Pilot pressure for pneumatic control unit depends on the pressure of the flow medium; it must be between 2 ... 10 bar (at least 70% of operating pressure).

NOTE!

Pressure difference between port 1 and 3 of at least 2 bar.
When temperatures are below 0 °C then operation is restricted to dried air.

Ambient temperature	-10 ... +55 °C
Medium temperature	-10 ... +50 °C
Medium	<ul style="list-style-type: none"> • filtered compressed air (particle size max. 10 µm), preferably unlubricated (operation with lubricated air is possible) • neutral gases (5 µm filtering)
Seal material	NBR
Operating pressure range	2 ... 10 bar

6.3 Electrical data

Electrical connection	Cable plug Type 2516 on the plug contacts of the coil (torque for fastening: 1 Nm).
Voltage tolerance	±10%
Degree of protection	IP65 (only in conjunction with cable plug Type 2516)
Cable plug	Can be mounted offset by 180° for the cable outlet selected.

Important information to ensure functional reliability during continuous operation.

If continuous operation is interrupted then minimum activity of 1-2 witching operations per day are recommended for the duration of the downtime.

NOTE!

Damage to the device due to electrical voltage

- ▶ Pay attention to the voltage and if there is alternating current make sure to use cable plug type 2516 or a rectifier

NOTE!

Damage to the appliance when screwing the cable plug.

- ▶ Make sure that the flat seal is seated properly.

6.4 Type label

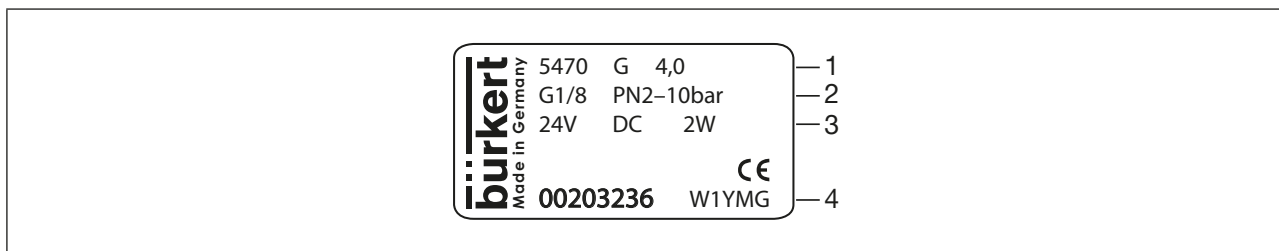

Figure 4: Example of a type label inscription

Item	Text	Designation
1	5470	Type
	G	Circuit function
	4.0	Orifice
2	G1/8	Connection type
	PN2-10bar	Operating pressure range
3	24 V DC	Voltage
	2W	Power
4	00203236	Article number
	W1YMG	Manufacture code (encrypted)

7 INSTALLATION

DANGER!

Risk of injury due to high pressure and escaping medium.

- ▶ Switch off the pressure before working on the device or system.
Vent or drain the pipes.

Risk of injury due to electric shock.

- ▶ Switch off voltage before working on the device or system. Secure against reactivation.
- ▶ Observe any applicable accident prevention and safety regulations for electrical devices.

WARNING!

Risk of injury from quickly accelerating device parts and unconnected compressed air hoses flapping around.

- ▶ Before applying pressure to the valve, check all hose connections and fittings for tight, secure fit.

Risk of injury due to improper installation.

- ▶ Only trained technicians may perform installation work.
- ▶ Perform installation work using suitable tools only.

Risk of injury due to unintentional activation of the system and uncontrolled restart.

- ▶ Secure the system against unintentional activation.
- ▶ Following installation, ensure a controlled restart.

Prior to installation

- Clean the pipes.
- If necessary, attach dirt trap upstream.
- Do not use the coil as a lever when screwing in the connections.

7.1 Rotating the solenoid

CAUTION!

Danger of electric shock if the coil is installed incorrectly.

- ▶ When installing, make sure that the coil is firmly seated on the valve body so the protective conductor connection of the coil is connected to the valve body.
- ▶ Check the protective conductor function (see “Table 2: Protective conductor function test values”)

Valves are delivered fully assembled. If the location of the solenoid of the pilot valve is not suitable for installation then the solenoid can be rotated 180°.

→ Loosen screw M2 and remove the coil from the valve body.

→ Rotate the coil, place back onto the valve body and then screw back into position in stages with M2 screws.

→ Observe the tightening torque:

1. Increment of 0.1 Nm (± 0.05 Nm)
2. Increment of 0.2 Nm (± 0.05 Nm)

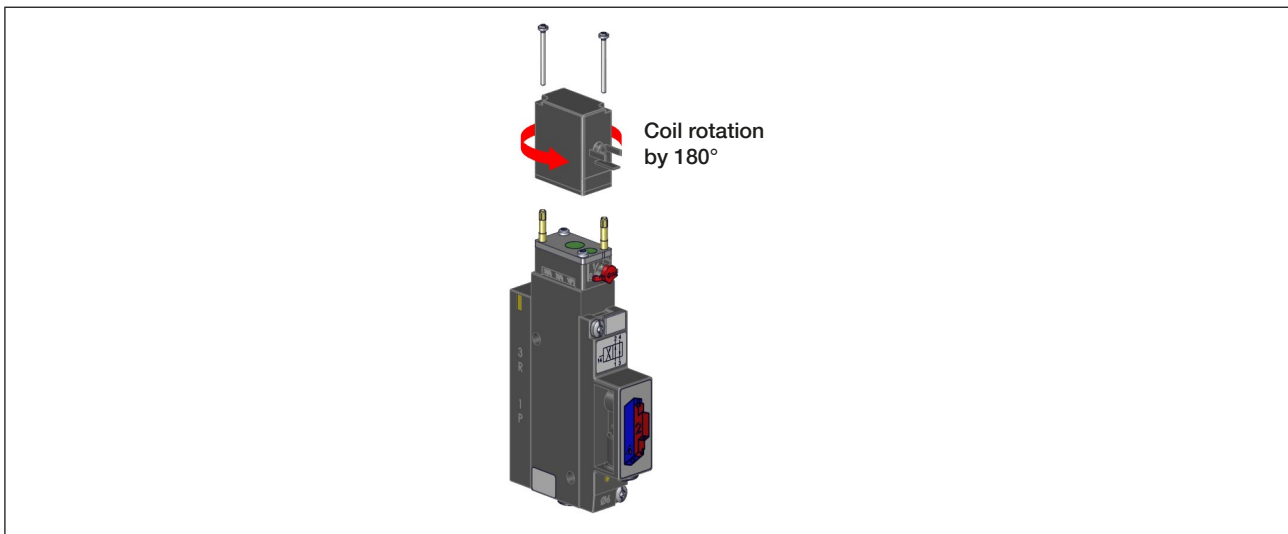

Figure 5: Rotating the solenoid on type 5470

7.2 Installing multiple blocks

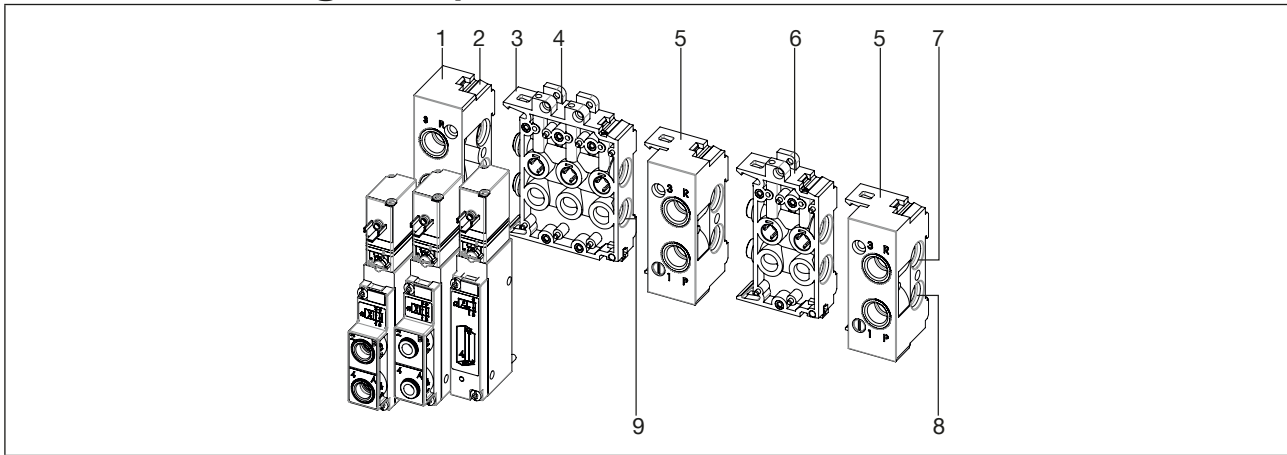

Figure 6: Example of a multi-block

Item	Designation
1	Left connection module
2	Latch tab
3	Latch hook
4	Base modules 3-fold
5	Right connection module
6	Base modules 2-fold
7	Exhaust channel 3(R)
8	Supply channel 1(P)
9	O-ring

- Begin installation with connection module on the left (see “Figure 6”)
- Check modules for complete installation with 2 O-rings each.
- Lightly oil or grease all O-rings before engaging.
- Engage the lower latch hooks of the module to be attached in the latch grooves of the preceding module. Make sure that the O-rings are properly seated.
- Press the module to be locked upwards slightly and engage the upper latch hook.
- Insert 3 O-rings into the recess on the back of the valve and ensure that the seal is properly fitted.

! Crushed O-rings and profile seals lead to leaky blocks.

- Fasten each valve to the base module with 2 screws. Recommended tightening torque 0.6 ± 0.1 Nm.

7.3 Valve block installation

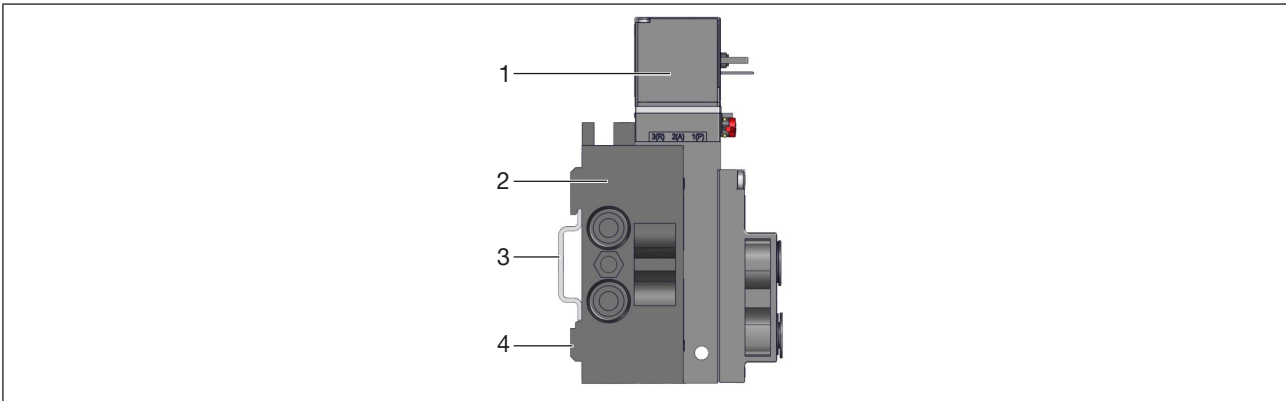

Figure 7: Mounting the valve block

Item	Designation
1	Electrical connection can be rotated by 180°
2	Wall mount
3	Standard rail 35 x 15 or 35 x 7.5 EN 50022
4	Connection module

7.3.1 Standard rail installation

- Hook the valve block with the upper groove into the standard rail.
- Snap the lower clamping pieces into the standard rail.
- Tighten the screws on the clamping pieces.

Standard rail

- Standard rail 35 x 15 or 35 x 7.5 EN 50022

7.3.2 Wall installation

- Fasten the valve block directly to the wall with M4 screws

7.4 Single valve installation

→ Fasten single valves directly to the wall with M4 screws (see “Figure 8”).

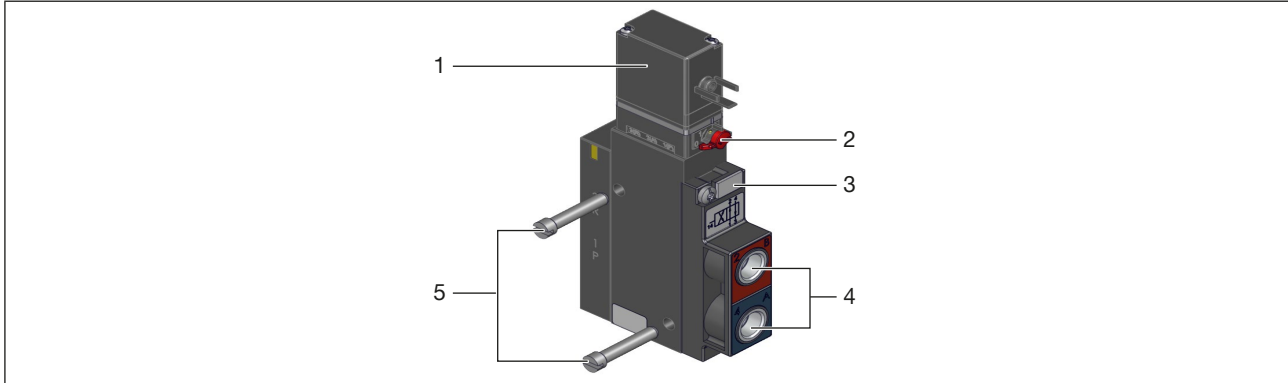

Figure 8: Fastening single valves

Item	Designation
1	Pilot valve
2	Manual override (see “5.1.1 Manual override”)
3	Description label
4	Working connections 2(B) and 4(A)
5	M4 screw

7.4.1 Tightening torques for port connections

Observe the following tightening torques when screwing into the port connections:

Port size	Marking/function	Recommended tightening torque [Nm]	Maximum tightening torque [Nm]
G1/4	P, R/S connection	15 ±2	20
NPT1/4			
G1/8	P, R/S connection A/B valve outlets	5 ±0.7	7
NPT1/8			

For an illustration of the connections, see “Figure 8”.

8 INSTALLATION

WARNING!

Risk of injury due to improper installation

- ▶ Only trained technicians may perform installation work.
- ▶ Only carry out installations with suitable tools.

Risk of injury due to unintentional activation of the system and uncontrolled restart.

- ▶ Secure the system against unintentional activation.
- ▶ Following installation, ensure a controlled restart.

8.1 Pneumatic installation

DANGER!

Risk of injury due to high pressure and escaping medium.

- ▶ Switch off the pressure before working on the device or system.
Vent or drain the pipes.

DANGER!

Risk of injury from quickly accelerating device parts and unconnected compressed air hoses flapping around.

- ▶ Before applying pressure to the valve, check all hose connections and fittings for tight, secure fit.

Installation position of the valves:

- any, preferably solenoid actuator on top

Before connection

- Check the hose lines for contamination and clean them.
- If necessary, install dirt traps upstream of the valve inlet ($\leq 5 \mu\text{m}$).

Pneumatic connection:

NOTE!

Breaking hazard

- ▶ Do not use the coil as a lever arm.
- ▶ Do not use a pipe wrench when screwing in.

NOTE!

Note the assignment of the connections (see Chapter [“5.1.2 Connections”](#))

- Push the hose lines into the push-in connections of the solenoid valves until they come to a stop.
- Use PTFE tape or elastomer seal for sealing the threaded connection.
- Align hose lines
- Connect the supply and working lines to the valve block.

Requirements for hose lines

- Minimum hardness 40 Shore D (according to DIN 53505 or ISO 868).
- Outer diameter according to DIN 73378 (maximum permissible deviation ± 0.1 mm from nominal dimension).
- Burr-free, cut off at right angles and undamaged on the outer diameter surface.

8.2 Recommended action for push-in connectors

Our push-in connectors meet the requirements specified in the ISO 14743:2020 standard. However, if you encounter leakage or retention problems when installing pneumatic hoses in the push-in connectors, you can take the following measures:

Use suitable materials

- Ensure that the appropriate combination of hose material (polyamide or polyurethane) and push-in connector is used, as different materials require different holding forces.

Check the hose size

- Ensure that the outer diameter of the hose matches the specification of the push-in connector. Hoses that are too small or too large may not sit correctly in the push-in connector.

According to ISO 14743:2020, depending on the outer diameter (OD) of the hose, the tolerances must not exceed the following values:

Material	Hose OD [mm]	Permitted deviation OD [mm]
Polyamide (PA)	3...10	± 0.08
	12...16	± 0.1
Polyurethane (PU)	3...8	± 0.1
	10...16	± 0.15

Check the hose for damage

- Check the hose for visible damage such as cracks, kinks or wear. Such defects can prevent the hose from seating properly in the push-in connector.

Cut the hose correctly

→ Cut the hose straight. Cutting it diagonally adversely affects the holding force. If the hose is not seated evenly in the push-in connector, the holding force is reduced and the seal between the push-in connector and hose is no longer sufficient. Furthermore, the pressure will be distributed unevenly in the system, which can cause the hose to slip or be pulled out of the push-in connector under pressure.

Insert the hose correctly

→ Press the hose into the push-in connector with sufficient force. The hose must be inserted deep enough into the push-in connector so that it is held correctly by the claws.

Check the push-in connector system

→ Ensure that the push-in connector system is designed for the corresponding operating conditions. The push-in connectors must function reliably at pressures from -0.09 MPa (-0.9 bar) to 1.6 MPa (16 bar) and be designed for temperatures from -20 °C to +80 °C. Even if the operating conditions for push-in connectors are specified in accordance with ISO 14743:2020, the specific operating conditions of the product used (e.g. those of a valve island) must be taken into account.

Check the holding capacity of the push-in connector

→ When installing the hose, make sure that it is firmly seated in the push-in connector and can reliably withstand the specified minimum tensile forces to ensure a secure connection. It is recommended not to increase the load beyond what is necessary, as excessive tensile force can impair the function and safety of the connection.

For orientation: depending on body weight and fitness, an average person can apply forces of around 300 to 500 N when pulling.

Hose OD, D, mm	3	4	6	8	10	12	14	16
Hose OD, D, in (mm)	1/8 (3.17)	5/32 (4)	1/4 (6.35)	5/16 (8)	3/8 (9.52)	1/2 (12.7)	-	5/8 (16)
Minimum tensile force for polyamide hose (PA), N	60	70	120	170	250	300	300	350
Minimum tensile force for polyurethane hose (PU), N	25	50	100	150	200	200	250	300

Table 1: Minimum tensile force for the tensile test (DIN ISO 14743:2020)

If the problem persists despite the measures taken, it is possible to use support sleeves (ID 20099400). These sleeves help to increase the stability and tightness of hoses in push-in connectors. This is particularly important when softer or more flexible hoses such as polyurethane (PU) ones are used.

8.3 Electrical installation

DANGER!

Risk of injury due to electric shock.

- ▶ Switch off voltage before working on the device or system. Secure against reactivation.
- ▶ Observe any applicable accident prevention and safety regulations for electrical devices.
- ▶ When screwing in the solenoid with the cable plug, make sure that the seal is properly seated.

If there is no protective conductor contact between the coil and the housing, there is a risk of electric shock!

- ▶ Always connect the protective conductor.
- ▶ Check electrical continuity between coil and body.

8.3.1 Electrical installation of cable plugs

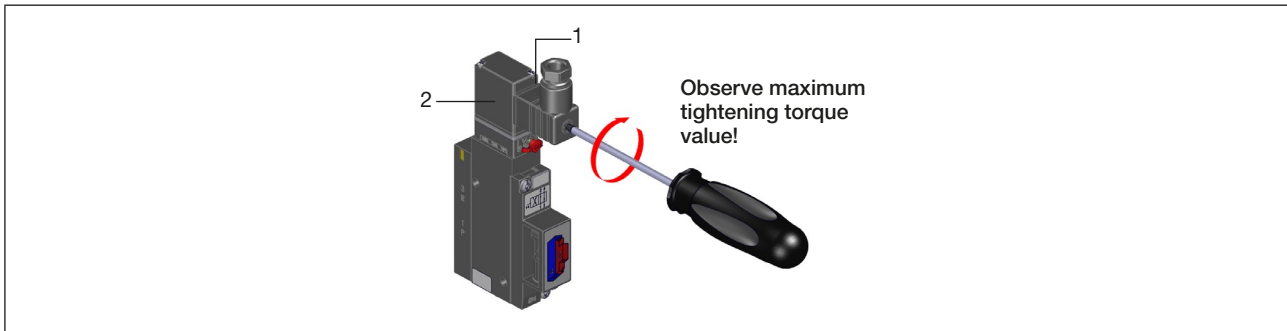

Figure 9: Connection of the cable plug

Item	Designation
1	Seal
2	Approved cable plug, e.g. Type 2516 or other according to DIN ISO 175301-803 Form C

→ Screw on the cable plug (see data sheet for approved types), observing the maximum tightening torque of 0.3 Nm.

→ Check that the seal is correctly fitted.

→ Connect the protective conductor and check electrical continuity between coil and housing (see “Table 2: Protective conductor function test values”).

Resistance	Test voltage	Test current
Maximum 0.1 Ω	12 V	1 A

Table 2: Protective conductor function test values

8.3.2 Impulse design control unit

NOTE!

The correct polarity is a prerequisite to ensuring that the device functions. Note the label on the surface of the coil. Pulse duration at least 50 ms.

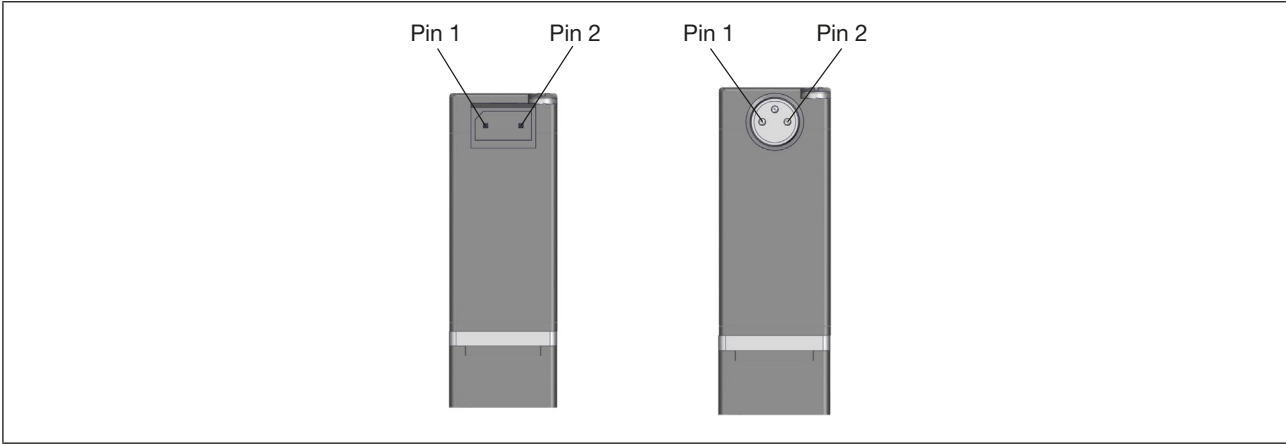

Plug configuration	Effect		
	(+) on pin 2 (-) on pin 1	Pilot valve opened	1-3
2-3			
		1-4	WWC
(+) on pin 1 (-) on pin 2	Pilot valve closed	1-2	WWG
		4-3	
		4-3	WWC

9 START-UP

WARNING!

Risk of injury due to improper operation.

- ▶ Prior to start-up, it must be ensured that the operating personnel are familiar with and fully understand the contents of the operating instructions.
- ▶ Only authorised technicians may start up the device or system.

→ Check connections, voltage and operating pressure.

→ Observe data on the type label.

→ Check the correct pin assignment of connections 1 and 3. Do not mix them up under any circumstances.

→ For electrical operation, unlock the manual override.

10 MAINTENANCE, TROUBLESHOOTING

WARNING!

Risk of injury if maintenance work is not carried out correctly.

- ▶ Only trained technicians may perform maintenance work.
- ▶ Perform maintenance work using suitable tools only.

Risk of injury due to unintentional activation of the system and uncontrolled restart.

- ▶ Secure the system against unintentional activation.
- ▶ Ensure a controlled restart after maintenance is completed.

Fault	Possible cause	Remedy
Valves do not switch	No operating voltage or operating voltage too low	Check electrical connection Ensure operating voltage according to type label.
	Manual override not in zero position	Bring manual override to zero position.
	Pressure supply insufficient or not available	Set up large-volume pressure supply (also for upstream devices such as pressure controllers, maintenance units, on/off valves, etc.) Minimum operating pressure \geq 2 bar
Valves switch with a delay or blow off at the exhaust ports	Pressure supply insufficient or not available	Set up large-volume pressure supply (also for upstream devices such as pressure controllers, maintenance units, on/off valves, etc.) Minimum operating pressure \geq 2 bar
	Valves are not in the home position (de-energised) during pressure build-up	Apply pressure to the valve block before the valves are switched.
	Insufficient ventilation of the exhaust air ducts due to too small or dirty silencers (back pressure)	Use suitably sized silencers or expansion vessels. Clean the dirty silencers.
	Impurities or foreign matter in the pilot or pneumatic valve	Apply pulsed pressure to the exhaust air ducts to blow out the impurities. Install a new pilot or pneumatic valve.
Leaky valve blocks	Missing or crushed O-rings between the modules	Identify leak or missing seals
	Missing or incorrectly positioned flat seals between valve and base plate	Insert missing seals or replace damaged seals

11 DISASSEMBLY

WARNING!

Risk of injury due to high pressure and escaping medium.

- ▶ Switch off the pressure before working on the device or system. Vent or drain the pipes.

Risk of injury due to electric shock.

- ▶ Switch off voltage before working on the device or system. Secure against reactivation.
- ▶ Observe any applicable accident prevention and safety regulations for electrical devices.

WARNING!

Risk of injury due to improper disassembly.

- ▶ Only trained specialist personnel may carry out the disassembly.
- ▶ Perform disassembly work using suitable tools only.

Risk of injury from dangerous fluids.

- ▶ Before loosening lines or valves, flush out hazardous media, depressurise and drain the lines.

11.1 Valve block disassembly

- Loosen the clamping screws (approx. 4 turns).
- Remove the block upwards from the standard rail.

11.2 Disassembling multi-blocks

- Use the screwdriver to disengage the upper latch hook from the disassembly groove on the front side.
- Remove the sub-block/module from the side.

11.3 Disassembling hose lines

- To release the lines, push in the thrust collar and pull out the hose line.

12 RIGHT CONNECTION MODULE

Other application options:

- Connection modules on the right can be used in special applications as sub-modules to build up several operating pressure stages in one block.
- Makes additional feed possible for larger valve blocks.

NOTE!

If necessary, pierce the lateral predetermined breaking points of connections 1 and 3.

13 TRANSPORTATION, STORAGE, DISPOSAL

NOTE!

Damage in transit due to inadequately protected devices.

- ▶ Protect the device against moisture and dirt in shock-resistant packaging during transportation.
- ▶ Observe permitted storage temperature.
- ▶ Protect the electrical interfaces of the coil and the pneumatic connections from damage by placing protective caps on them.

Incorrect storage may damage the device.

- ▶ Store the device in a dry and dust-free location.
- ▶ Storage temperature: $-40\dots+55\text{ }^{\circ}\text{C}$.

Environmentally friendly disposal



- ▶ Follow national regulations regarding disposal and the environment.
- ▶ Collect electrical and electronic devices separately and dispose of them as special waste.

Further information country.burkert.com.