

Type 8605

Digital Control Electronics for Proportional Valves



Operating Instructions

We reserve the right to make technical changes without notice.
Technische Änderungen vorbehalten.
Sous réserve de modifications techniques.

© Bürkert Werke GmbH & Co. KG, 2007 - 2026

Operating Instructions 2602/07_EU-EN_00805613 / Original DE

Digital Control Electronics Type 8605

CONTENTS

1.	OPERATING INSTRUCTIONS.....	5
1.1.	Symbols.....	5
1.2.	Definition of Term "Device".....	5
2.	INTENDED USE.....	6
3.	BASIC SAFETY INSTRUCTIONS.....	7
4.	GENERAL INFORMATION.....	8
4.1.	Contact address.....	8
4.2.	Warranty.....	8
4.3.	Information on the Internet.....	8
4.4.	Compatibility Control Unit Rev.3.....	8
5.	PRODUCT DESCRIPTION.....	9
5.1.	Field of Application.....	9
5.2.	General Description.....	9
5.3.	Form of the Device.....	9
5.3.1.	Type 8605 Cable plug version.....	9
5.3.2.	Type 8605 DIN rail version.....	10
6.	TECHNICAL DATA.....	11
6.1.	Operating Conditions.....	11
7.	CONFIGURATION AND FUNCTION.....	12
7.1.	Operating and Display Elements.....	12
7.1.1.	Operating unit.....	12
7.1.2.	LED's during operation without operating unit.....	13
7.2.	Basic function.....	13
7.3.	Adjustment to the Valve and Application Data.....	14
8.	INSTALLATION.....	16
8.1.	Safety instructions.....	16

8.2.	Electrical connections	16
8.2.1.	Cable plug version	16
8.2.2.	DIN rail version.....	18
9.	CONFIGURATION	20
9.1.	Operating modes	20
9.2.	Basic settings	20
9.3.	Menu of the configuration mode	21
9.3.1.	InP (Input) - Selection of the input signal	22
9.3.2.	Out (Output) - Valve settings	22
9.3.3.	VAdJ (Valve adjust) - Fine tuning of the valve frequency.....	25
9.3.4.	AdJ (Adjust) - Adaptation of the coil current	26
9.3.5.	dELY (Delay) - Ramp function	27
9.3.6.	Cut (Cut off) - Zero point cut off	28
9.3.7.	PArA (Parameter) - Controller setting	29
9.3.8.	SPOS (Safe position) - Setting of the safety position.....	29
9.3.9.	dAtA (Data) - Upload and Download of parameters between the operating unit and the basic device.....	30
9.3.10.	END	30
9.4.	Factory Settings of the Control Electronics	31
10.	MAINTENANCE	32
10.1.	Safety Instructions	32
10.2.	Service	32
11.	SPARE PARTS	33
11.1.	Ordering charts: Device variants	33
11.2.	Accessories	34
12.	PACKAGING, TRANSPORT	35
13.	STORAGE	35
13.1.	Decommissioning	35
13.2.	Restarting	35
14.	DISPOSAL	36

1. OPERATING INSTRUCTIONS

The operating instructions describe the entire life cycle of the device. Keep these instructions in a location which is easily accessible to every user and make these instructions available to every new owner of the device.



WARNING!

The operating instructions contain important safety information!

Failure to observe these instructions may result in hazardous situations.

- The operating instructions must be read and understood.

1.1. Symbols



DANGER!

Warns of an immediate danger!

- Failure to observe the warning may result in a fatal or serious injury.



WARNING!

Warns of a potentially dangerous situation!

- Failure to observe the warning may result in serious injuries or death.



CAUTION!

Warns of a possible danger!

- Failure to observe the warning may result in moderately serious or minor injuries.

NOTE!

Warns of damage to property!

- Failure to observe the warning may result in damage to the device or the equipment.



Designates additional significant information, tips and recommendations.



Refers to information in these operating instructions or in other documentation.

→ designates a procedure which you must carry out.

1.2. Definition of Term “Device”

The term “device” used in these instructions always stands for the electromagnetic positioner type 8605.

2. INTENDED USE

Non-intended use of the Type 8605 may be a hazard to people, nearby equipment and the environment.

- The device is designed for controlling Bürkert proportional valves.
- The device must not be exposed to direct sunlight.
- Do not use the device outdoors.
- To ensure that the device functions perfectly, set the PWM frequency which is suitable for the valve. A table of set values can be found on the Bürkert homepage www.burkert.com → Type 8605.
- Use according to the authorized data, operating conditions and conditions of use specified in the contract documents and operating instructions. These are described in the chapter entitled "[6. Technical Data](#)".
- The device may be used only in conjunction with third-party devices and components recommended and authorized by Bürkert.
- Correct transportation, correct storage and installation and careful use and maintenance are essential for reliable and faultless operation.
- Use the device only as intended.

3. BASIC SAFETY INSTRUCTIONS

These safety instructions do not make allowance for any:

- Contingencies and events which may arise during the installation, operation and maintenance of the devices.
- Local safety regulations – the operator is responsible for observing these regulations, also with reference to the installation personnel.



Danger – high pressure!

- Before loosening the lines and valves, turn off the pressure and vent the lines.

Risk of electric shock!

- Before reaching into the device or the equipment, switch off the power supply and secure to prevent reactivation!
- Observe applicable accident prevention and safety regulations for electrical equipment!

There is a risk of injury when the pressure drops in the system!

- Avoid pressure drops!
- Design the pressure supply system with as large a volume as possible, even with upline devices such as e. g. pressure regulators, air conditioners, shut-off valves.

General hazardous situations.

To prevent injury, ensure that:

- That the system cannot be activated unintentionally.
- Installation and repair work may be carried out by authorised technicians only and with the appropriate tools.
- After an interruption in the power supply or pneumatic supply, ensure that the process is restarted in a defined or controlled manner.
- The device may be operated only when in perfect condition and in consideration of the operating instructions.
- The general rules of technology apply to application planning and operation of the device.

NOTE!

Electrostatic sensitive components / modules!

The device contains electronic components which react sensitively to electrostatic discharge (ESD). Contact with electrostatically charged persons or objects is hazardous to these components. In the worst case scenario, they will be destroyed immediately or will fail after start-up.

- Observe the requirements in accordance with EN 61340-5-1 and 5-2 to minimise or avoid the possibility of damage caused by sudden electrostatic discharge!
- Do not touch live electronic components!



The Type 8605 was developed with due consideration given to the accepted safety rules and are state-of-the-art. Nevertheless, dangerous situations may occur.

Failure to observe this operating manual and its operating instructions as well as unauthorized tampering with the device release us from any liability and also invalidate the warranty covering the devices and accessories!

4. GENERAL INFORMATION

4.1. Contact address

Germany

Bürkert Fluid Control Systems
Sales Center
Chr.-Bürkert-Str. 13-17
D-74653 Ingelfingen
Tel. + 49 (0) 7940 - 10 91 111
Fax + 49 (0) 7940 - 10 91 448
E-mail: info@burkert.com

International

Contact addresses can be found on the final pages of the printed operating instructions.

And also on the Internet at:

www.burkert.com

4.2. Warranty

The warranty is only valid if the device is used as authorized in accordance with the specified application conditions.

4.3. Information on the Internet

Operating instructions and data sheet for Type 8605 can be found on the Internet at:

www.burkert.com

4.4. Compatibility Control Unit Rev.3

New version

A new version of the Control Unit Type 8605 has been available since Q3/2024. The current Version Rev.2 (Article No. 582878) is being replaced by Rev.3 (Article No. 20097278). The control electronics will also receive an update to Rev.3. The following combinations are compatible with each other:

Control Electronics	Control Unit Rev.2	Control Unit Rev.3
	(Article no. 582878)	(Article no. 20097278)
Rev.2	X	-
Rev.3	X	X

5. PRODUCT DESCRIPTION

5.1. Field of Application

The Control Electronics, Type 8605, is designed for continuous operation in industrial environments, in particular in the fields of open-loop and closed-loop control engineering.

5.2. General Description

The Digital Control Electronics for Proportional Valves, Type 8605 (hereinafter referred to as Control Electronics, Type 8605) controls all Bürkert proportional valves with a max. current in the range from 40 to 2000 mA.

It transforms an external standard signal into a pulse-width modulated voltage signal (PWM) that is supplied to the solenoid coil of the proportional valve.

A given value of the average coil current is thereby assigned to each value of the input signal. The proportional opening of the valve can be set via the coil current.

5.3. Form of the Device

The Control Electronics is available in two forms.

5.3.1. Type 8605 Cable plug version



Figure 1: Type 8605 Cable plug version

Plug-in version on valves with connector pattern A:

e. g. types 2832, 2833, 2834, 2835, 2836,
2853,
2863, 2865,
2873, 2875
6022, 6023, 6024,
6223.

The operating unit can be removed after the setting process. During operation of the Control Electronics 8605 in cable plug version without operating unit, the operating status is indicated by two LED's.

Device variants:

- Variant 1 for valves with a max. current from 200 to 1000 mA
- Variant 2 for valves with a max. current from 500 to 2000 mA

5.3.2. Type 8605 DIN rail version



Figure 2: Type 8605 DIN rail version

Separate electronics in housing for DIN rail mounting to DIN EN 50022. This form is suitable for all proportional valves in the indicated current range. The operating unit cannot be removed.

Device variants:

- Variant 1 for valves with a max. current from 40 to 220 mA
- Variant 2 for valves with a max. current from 200 to 1000 mA
- Variant 3 for valves with a max. current from 500 to 2000 mA

6. TECHNICAL DATA

6.1. Operating Conditions



WARNING!

The Type 8605 is not designed for use outdoors!

- Do not use the Type 8605 outdoors and avoid heat sources which may result in the permitted temperature range to be exceeded.

Power supply	12...24V DC \pm 10% Residual ripple 5 %
Power consumption	ca. 1 W
Output current (on the valve)	max. 2 A
Operating temperature	-10 ... 60° C / 14 ... 140°F
Interference resistance	to EN50082-2
Emission	to EN50081-2
Current range, depending on the version for valves	40 ... 220 mA, 200 ... 1000 mA, 500 ... 2000 mA

Standard signal input

Voltage (0 ... 5, 0 ... 10 V)	input impedance > 20 k Ω
Current (0 ... 20, 4 ... 20 mA)	input impedance < 200 Ω

Housing: DIN rail version

Degree of protection	IP40 (DIN EN 60529)
Materials	Polyamide / PBT
Dimensions	LxBxH: 97x27x57 mm

Housing: Cable plug version

Degree of protection	IP65 (DIN EN 60529)
Materials	Polyamide / PC
Dimensions	LxBxH: 70x32x42.5 mm

7. CONFIGURATION AND FUNCTION

7.1. Operating and Display Elements

7.1.1. Operating unit

The operating unit consists of a LCD and keys. It is used for displays and settings of the Control Electronics, Type 8605.

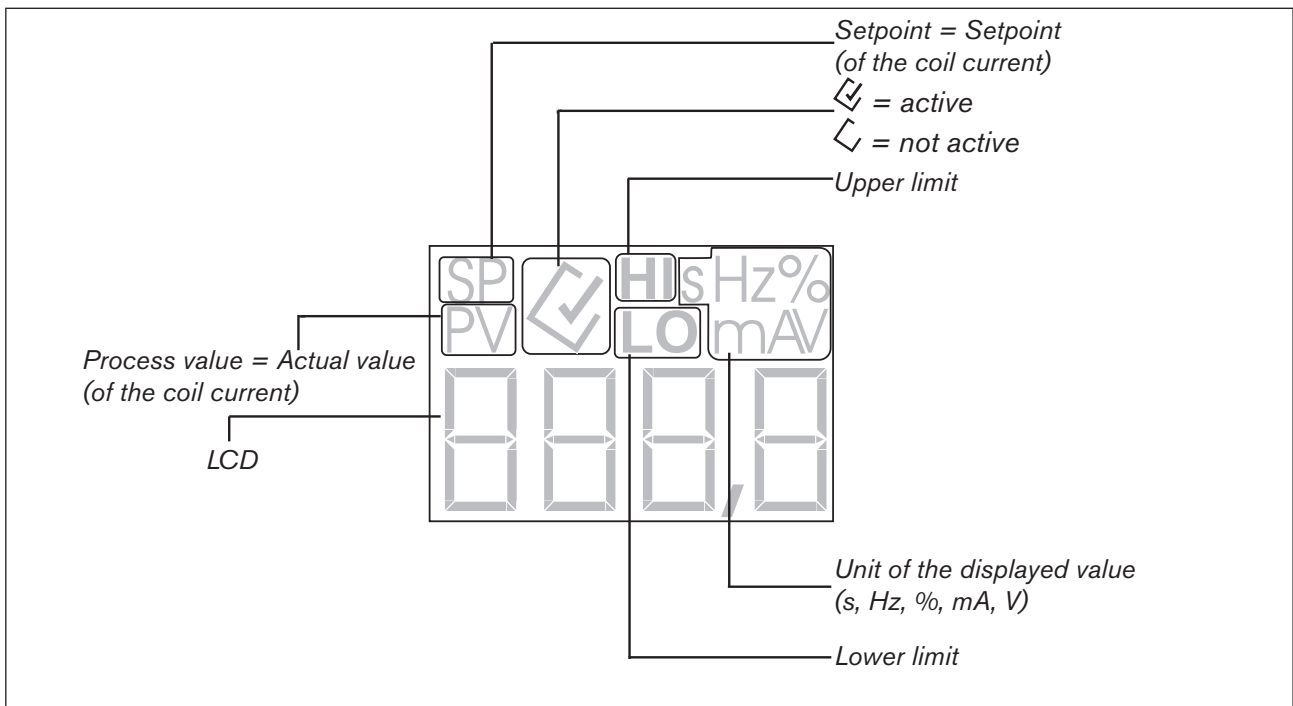

Figure 3: Operating unit

Key assignment:

Key	Display mode	Configuration mode	Selected and confirmed menu item
	Switch over the display value	Scroll up (selection)	Increment (increase) numerical values
	PV [mA] process value PV [%] process value SP [%] setpoint TV [%] duty cycle	Scroll down (selection)	Decrement (decrease) numerical values
	3 sec Enter configuration mode	Confirm the selected menu item	Select and deselect the individual menu items
		Switch between main-menu and sub-menu items e. g.: Out-VALV	Confirm set values

7.1.2. LED's during operation without operating unit

During operation of the Control Electronics 8605 without operating unit, the operating status is indicated by two LED's.

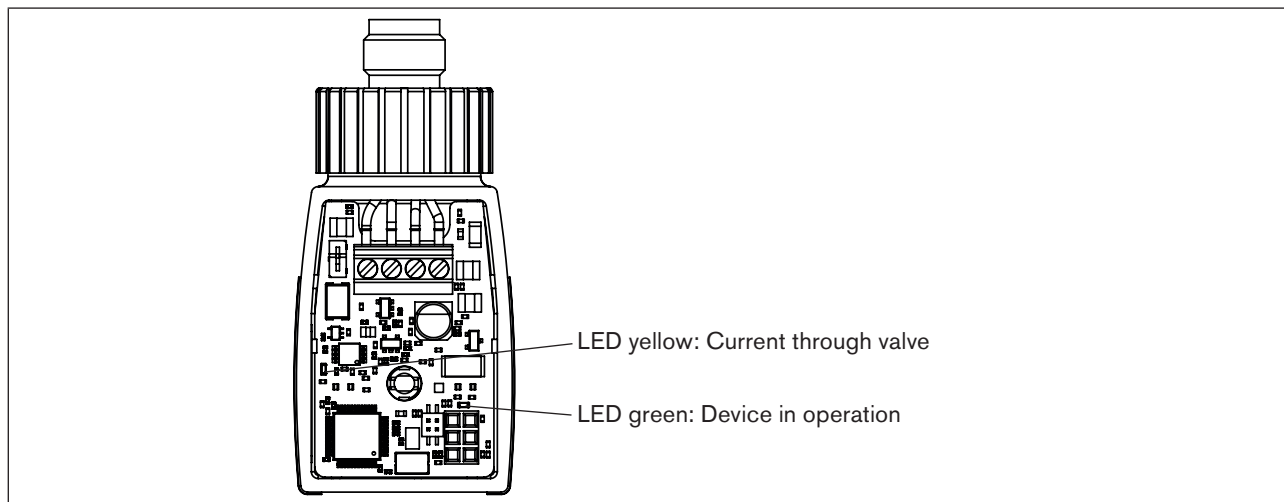

Figure 4: LED's on version without operating unit

7.2. Basic function

The Control Electronics, Type 8605, is suitable for the control of all Bürkert proportional valves with a max. current in the range from 40 to 2000 mA. It transforms an external standard signal into a pulse-width modulated voltage signal (PWM) that is supplied to the solenoid coil of the proportional valve (see "Figure 5: Basic function of the Control Electronics, Type 8605"). A given value of the average coil current is thereby assigned to each value of the input signal. The proportional opening of the valve can be set via the coil current.

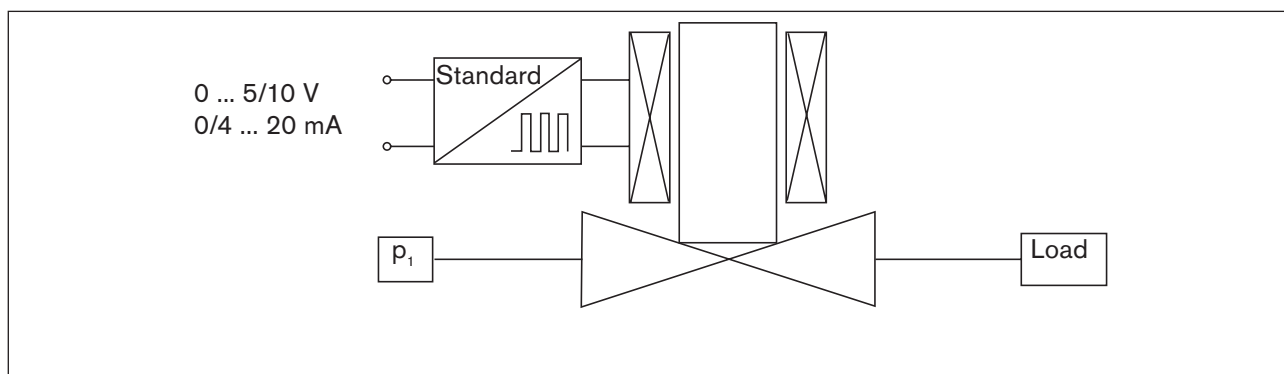

Figure 5: Basic function of the Control Electronics, Type 8605

0 to 5 V, 0 to 10 V, 0 to 20 mA or 4 to 20 mA can be set as standard signals.

Due to the inductivity of the coil, the rectangular time curve of the PWM voltage signals is not transformed into a corresponding current curve; instead the coil current has a sawtooth like „rounded“ time curve (see [“Figure 6: Time response of PWM voltage signal and coil current”](#)). The mean (effective) coil current over time depends on the pulse duty factor τ of the voltage signal.

$$\tau = t_{\text{on}} / (t_{\text{on}} + t_{\text{off}})$$

The curve of the coil current in the cycle of the PWM frequency generates a proportional change in the magnetic force acting on the armature and hence, with an appropriate choice of this frequency (see chapter [“7.3. Adjustment to the Valve and Application Data”](#)), a steady slight movement of the armature about its momentary equilibrium position (dither movement). This avoids static friction effects at the bearing points.

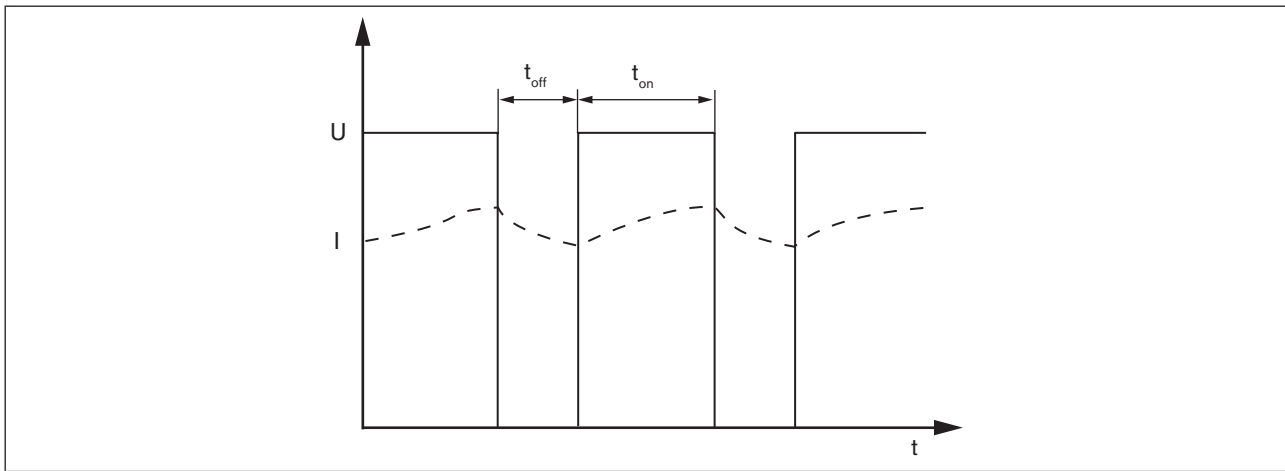

Figure 6: Time response of PWM voltage signal and coil current

Due to the intrinsic heating of the coil and the associated large changes in resistance of the winding, the coil current and hence the opening of the valve with a fixed pulse duty factor do not remain constant. An internal current control system serves to compensate these thermal effects by corresponding tracking of the pulse duty factor.

7.3. Adjustment to the Valve and Application Data

The working range of a valve in a particular application depends greatly on its nominal size and the prevailing pressure conditions.

In order to adapt the working range optimally to the range of the control signal, the key values for the effective coil current are set via the operating unit in such a way that:

- the opening of the valve starts at a current value slightly above the lower key value (I_1) and
- the full flow rate is achieved at a current value slightly below the upper key value (I_2).

The lower key value is the current controlled at the lowest value of the standard signal (0 V, 0 mA or 4 mA).

The upper key value is obtained at the maximum value of the standard signal (5 V, 10 V or 20 mA).

Between the two key values, the effective coil current has a linear relationship to the input signal (see [“Figure 7: Current over standard signal”](#))

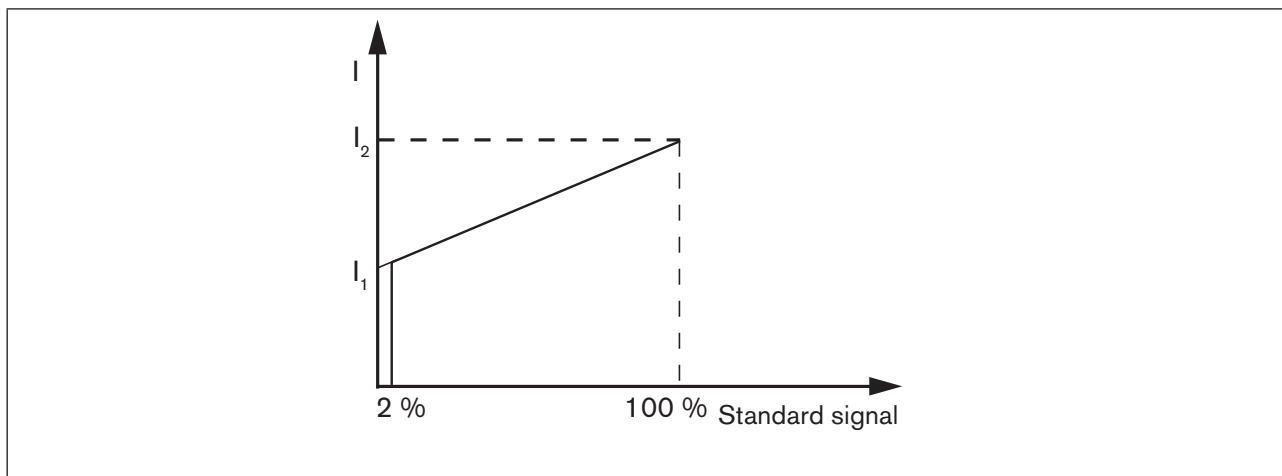

Figure 7: Current over standard signal

The working range can also be scaled using the key values I_1 and I_2 in such a way that only a part of the full opening of the valve is covered over the full range of the standard signal. In particular the flow rate range can be limited to a smaller value than the valve would permit under the given pressure conditions.

The zero point cut-off guarantees the leak-tight closing of the valve at input signals below a given threshold of the input signal (e.g. < 2 % of the limit value). In this case at values below this threshold, the coil current is set - in deviation from the line shown in [“Figure 7: Current over standard signal”](#) - to zero so that the full force of the return spring of the valve acts as a closing force.

The zero point cut-off can be optionally activated or deactivated.

A **ramp function** serves to attenuate sudden changes in the input signal and to transform them into an adjustable ramp (time constant 0 to 10 s) (see [“Figure 8: Ramp function”](#)). This is expedient for applications in which sudden changes in the fluidic controlled variable are undesirable. The ramps can be set separately for positive and negative jumps. The frequency of the PWM signal must be adapted to the valve used.

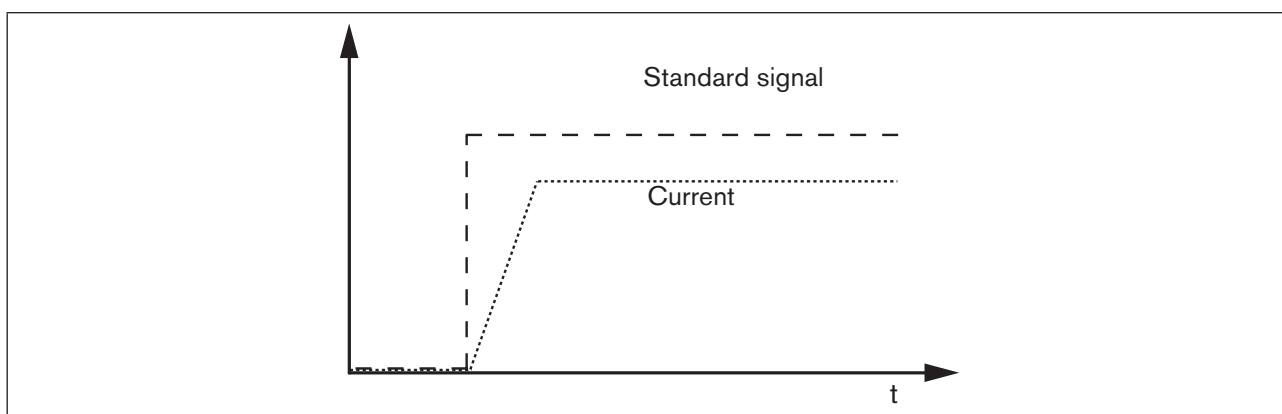

Figure 8: Ramp function

If digital communication with a higher-level controller is required, the “bÜS version for proportional valves” must be used. This is available separately (always without control unit!) and cannot be retrofitted with an existing standard digital control for Type 8605 Proportional Valves (see [“11.1. Ordering charts: Device variants”](#)).

8. INSTALLATION

8.1. Safety instructions



DANGER!

Risk of injury from high pressure in the equipment!

- Before loosening the lines and valves, turn off the pressure and vent the lines.

Risk of injury due to electrical shock!

- Before reaching into the device or the equipment, switch off the power supply and secure to prevent reactivation!
- Observe applicable accident prevention and safety regulations for electrical equipment!



WARNING!

Risk of injury from improper installation!

- Installation may be carried out by authorised technicians only and with the appropriate tools!

Risk of injury from unintentional activation of the system and an uncontrolled restart!

- Secure system from unintentional activation.
- Following assembly, ensure a controlled restart.

8.2. Electrical connections



DANGER!

Risk of injury due to electrical shock!

- Before reaching into the device or the equipment, switch off the power supply and secure to prevent reactivation!
- Observe applicable accident prevention and safety regulations for electrical equipment!

8.2.1. Cable plug version

The electrical connection of the Controller Type 8605 in cable plug version is made via a 4-pin terminal strip inside the device.

Cable:

- Diameter 6 ... 8 mm
- Cross-section max. 0.75 mm²
- Cable connections Cable gland or plug connector M12
4-pin

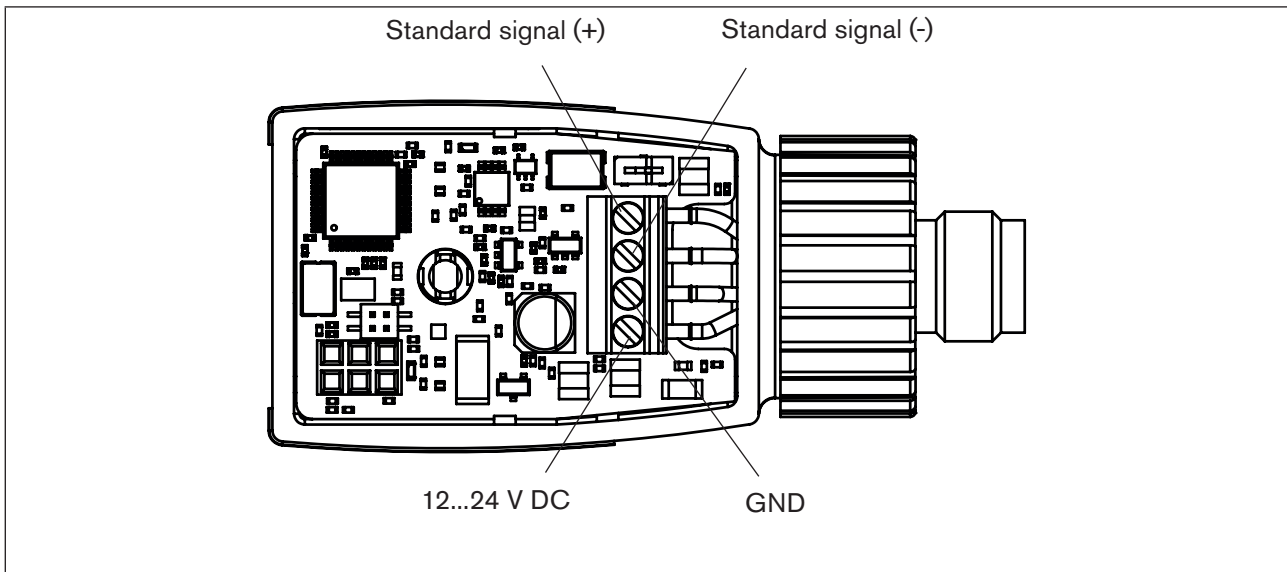

Figure 9: Terminal strip connection

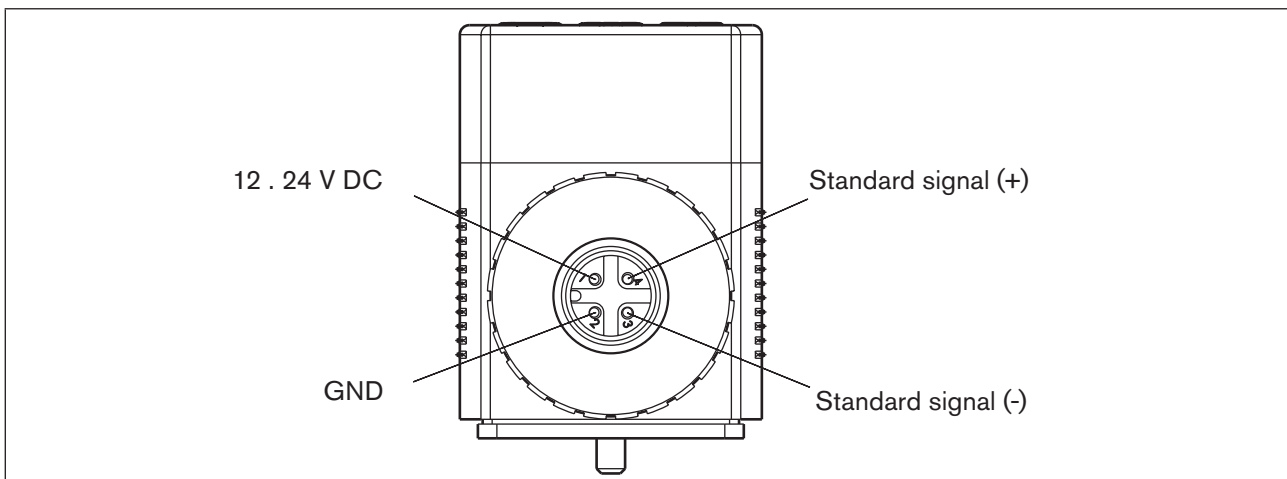

Figure 10: Plug connector connection

NOTE!

Ensure proper seating of the valve when screwing onto the valve (cable plug version)

Do not tighten the screw M3 too tightly (max. 0.3 Nm), as otherwise the housing will be deformed and proper operation of the keys will no longer be possible.

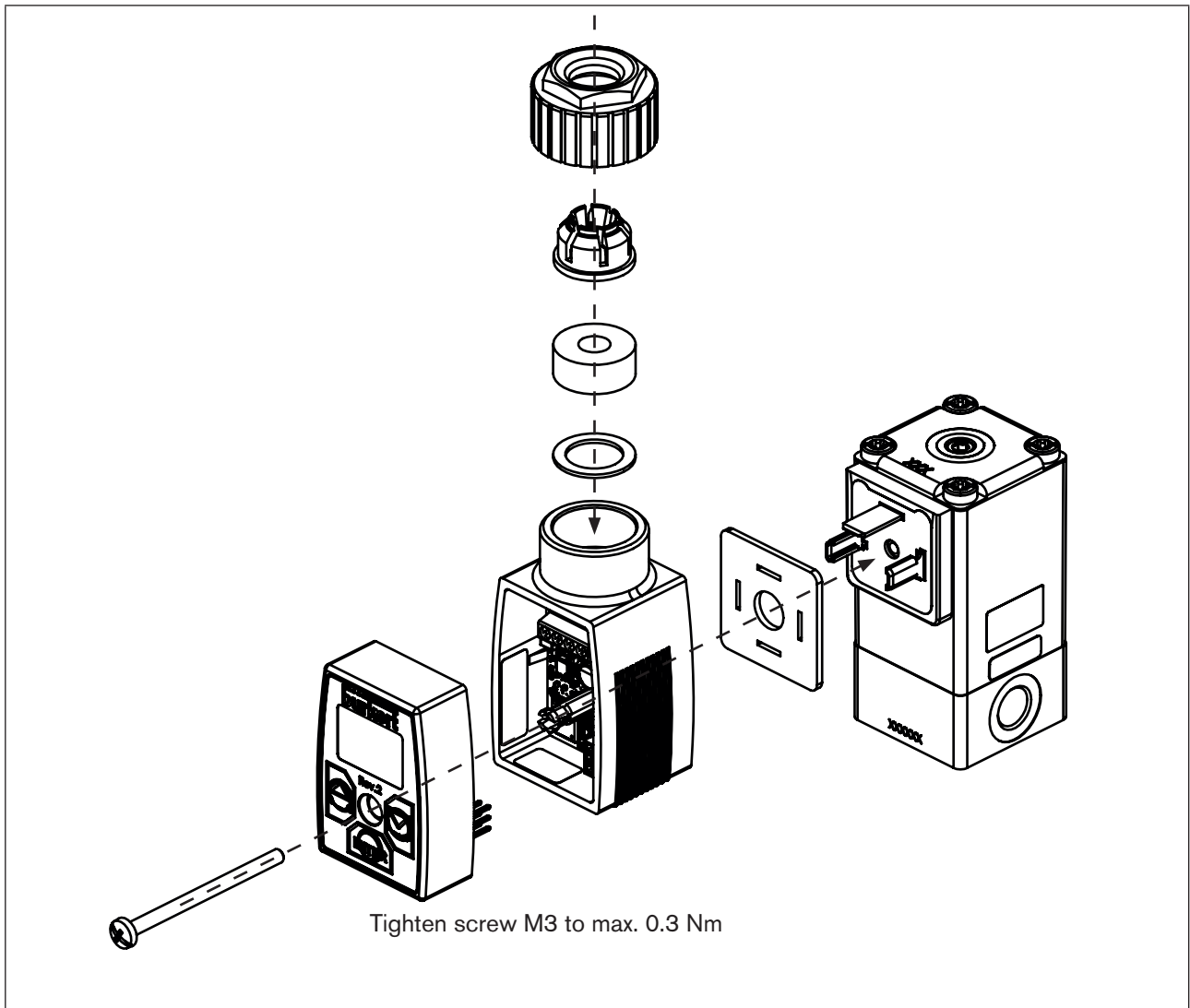

Figure 11: Installation of the cable plug version on the valve

8.2.2. DIN rail version

The electrical connection of the Controller Type 8605 in DIN rail version is made via terminal strips.

Terminal strip		Cable cross-section
2-pin	for valve	max. 1.5 mm ²
4-pin	for voltage supply and standard signal	max. 1.5 mm ²

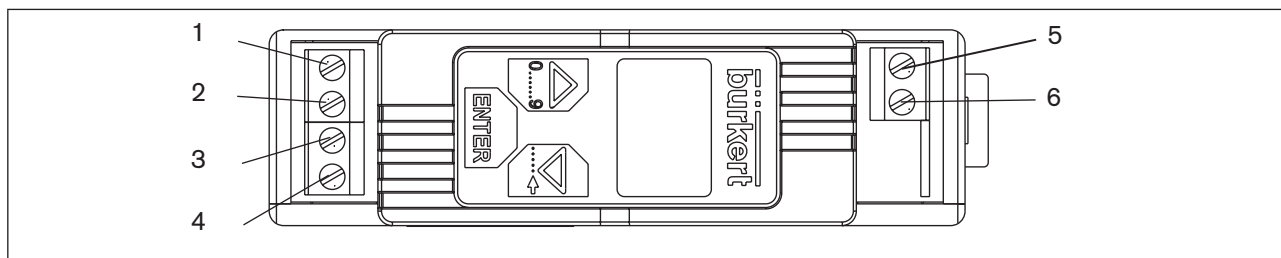

Figure 12: Terminal strip connection

Legend:

1. 12...24 V DC
2. GND
3. Standard signal (-)
4. Standard signal (+)
5. Valve
6. Valve

9. CONFIGURATION



WARNING!

Danger may result from improper use!

Improper use can result in personal injury or damage to the device.

- The Control Electronics, Type 8605 may only be operated by qualified personnel.

NOTE!

Carry out the fluidic and electrical installation before starting the configuration.

9.1. Operating modes

The Control Electronics can be operated in two modes:

- Display mode
- Configuration mode

After switching on the operating voltage, the Control Electronics, Type 8605 is in display mode.

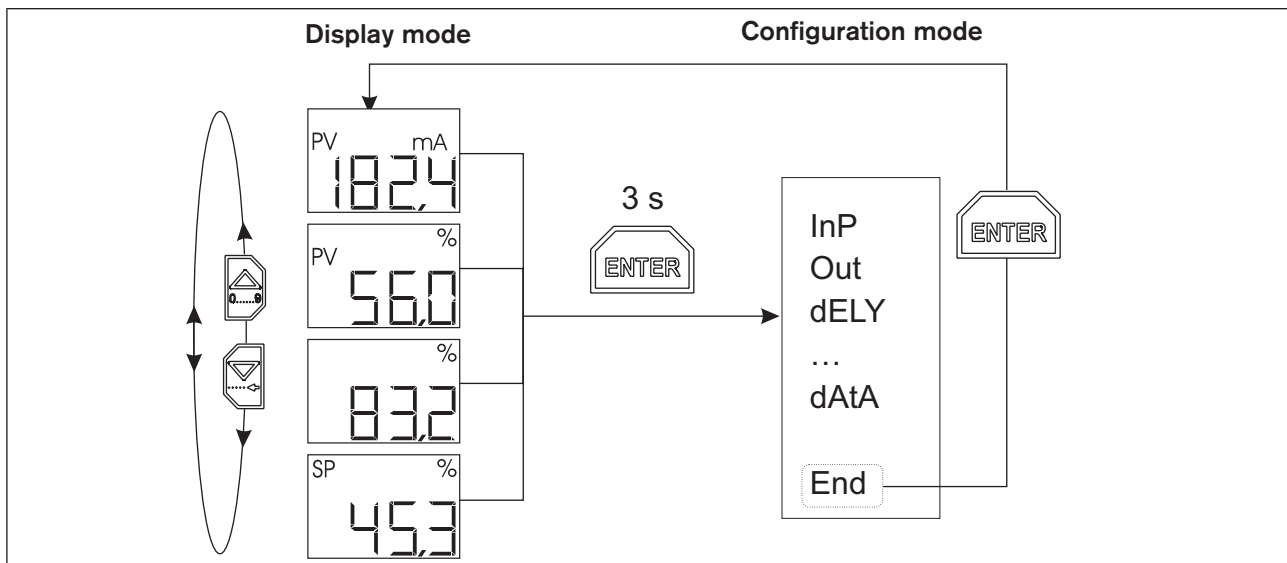

Figure 13: Switching between display and configuration mode

9.2. Basic settings

Switch to the configuration mode to make the basic settings.

→ Hold the Enter key depressed for 3 seconds.

InP, the first menu item of the configuration menu, appears on the display.

→ Press the Enter key to make settings in the menu item InP.

A sub-menu appears on the display.

You can switch between the sub-menu items by pressing the arrow keys and make the desired settings.

→ Confirm the desired setting by pressing the Enter key.

9.3. Menu of the configuration mode

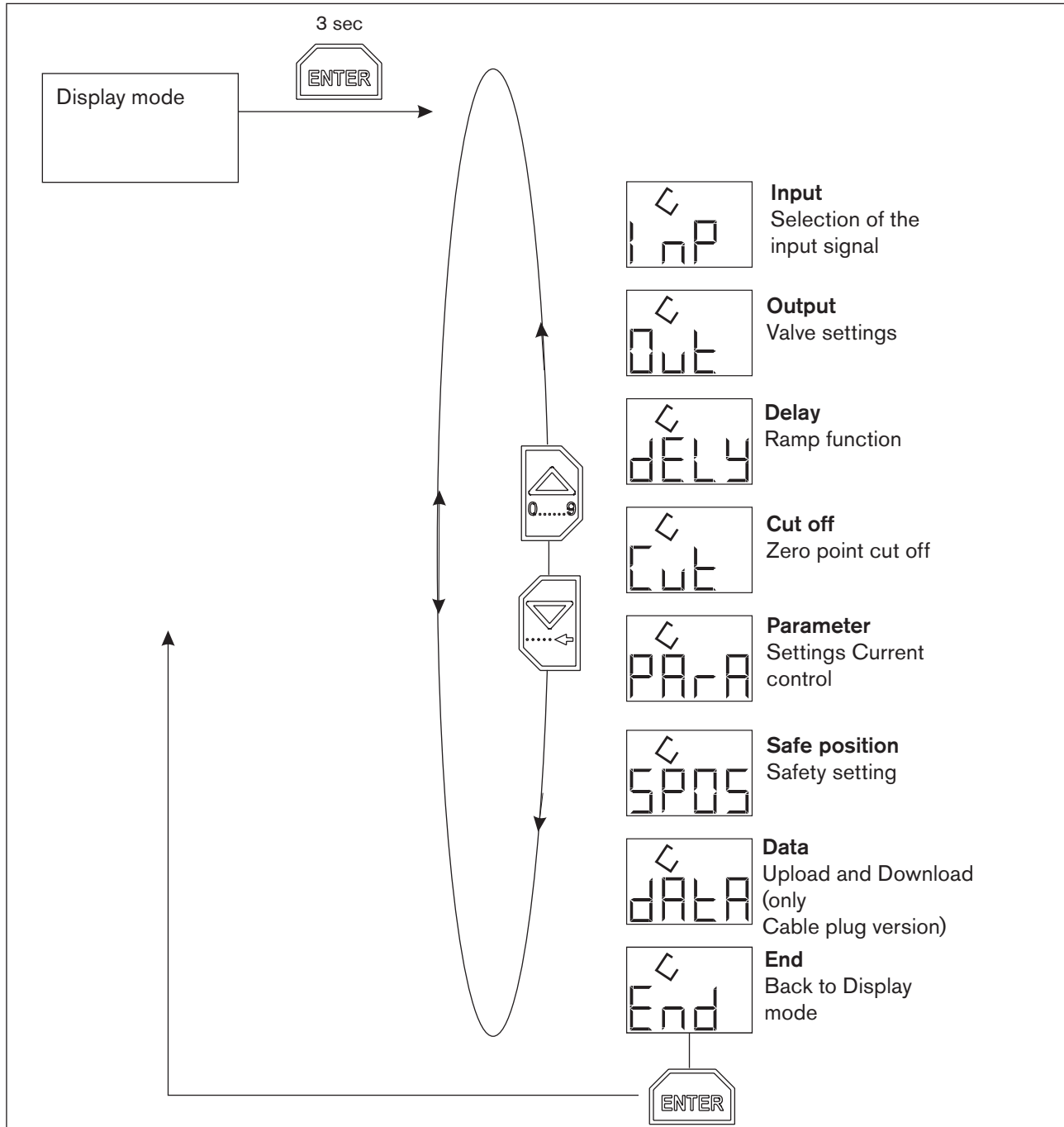

Figure 14: Menu of the configuration mode

9.3.1. InP (Input) - Selection of the input signal

Enter the type of standard signal used in this menu item. You can select between the following standard signals:

- 0 ... 5 V,
- 0 ... 10 V,
- 0 ... 20 mA,
- 4 ... 20 mA.

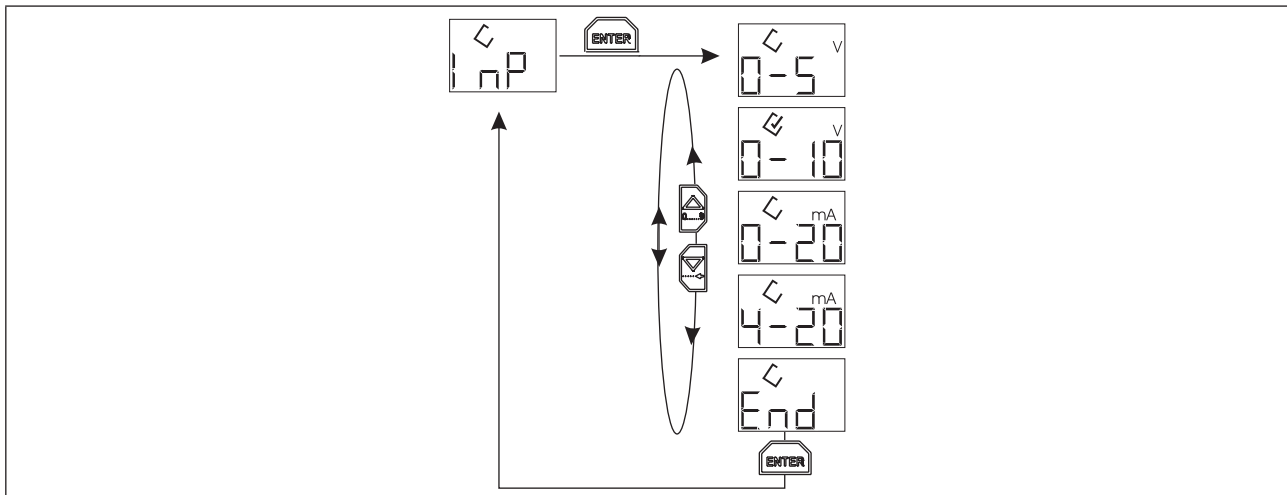

Figure 15: InP (Input) - Selection of the input signal

9.3.2. Out (Output) - Valve settings

In this menu the electronics are adjusted to

- the valve used and
- the fluidic conditions in the application.

Absolutely vital are

- the setting of the valve type in the sub-menu VALV and
- the setting of the working range of the coil current in the sub-menu AdJ.



To ensure that the device functions perfectly, set the PWM frequency which is suitable for the valve.

- For types 2871, 2873, and 2875, variants for higher differential pressures are available. These variants can be selected in the valve type selection using the suffix "LO". For the standard variants of these valve types 2871, 2873, and 2875, the suffix "HI" must be selected.
- In the case of special applications the PWM control frequency must be individually set in the VAdJ submenu. If you have any queries, please contact your sales office or the Bürkert Technical Center. 24 h service number: +49 (0) 7940 / 10 91 110

Set values for PWM frequencies:

A table of PWM frequencies which are suitable for controlling the valve type can be found on the Bürkert homepage: country.burkert.com → Typ 8605.

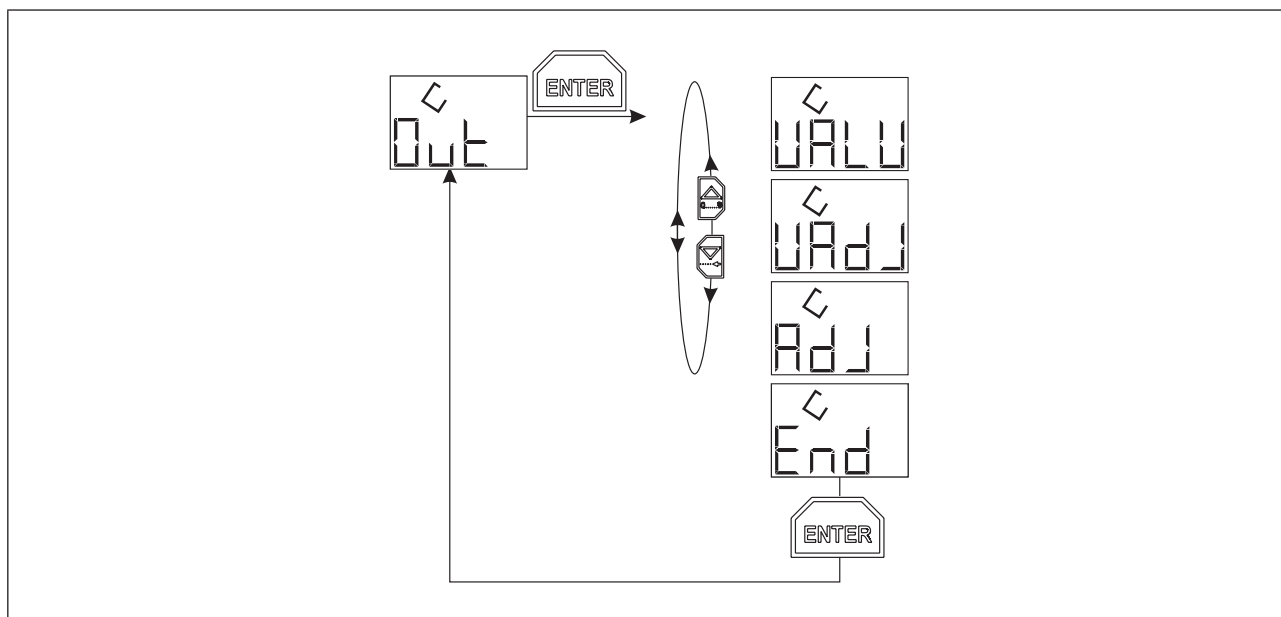

Figure 16: Out (output) - Valve setting

VALV (VALVE) - SETTING OF THE VALVE TYPE

CAUTION!

Danger from the selection of the wrong valve type!

The valve can be damaged if the wrong valve type is selected.

- Pay attention to the choice of the right valve type.

The Control Electronics, Type 8605, can be used for the whole range of Bürkert proportional valves. Depending on the nominal sizes and fluidic performance data, the individual valve types contain solenoid coils with very different sizes, winding data and dynamic properties (defined by the inductivity and Ohmic resistance).

The ability to react to a PWM voltage signal with a small dither movement and hence to give the valve a particularly good response depends to a very great extent on the dynamic characteristic of the coil.

As a general rule of thumb it can be said that small coils with low magnetic force still react well even to higher frequencies. At low frequencies, they even generate excessively large movement amplitudes and an unnecessarily high noise level. Large coils with high magnetic force still generate dither movements only at low frequencies and thus ensure sliding friction states.

The reaction of a valve to a PWM signal is dependent not only on its frequency but also on the current pulse duty factor τ and the working point.

The valve reacts more sensitively when the working point with average pulse duty factors $[\tau]$ and more slowly when the opening corresponds to a pulse duty factor in the limit areas close to 0 % or close to 100 %. In order to compensate this dependence, control is effected with a PWM frequency that is dependent on the pulse duty factor whose curve follows a triangular function (see "Figure 17: PWM frequency / pulse duty factor"). Here the frequency is lowest at the limit points (0 %, 100 %), and highest at $\tau = 60$ %.

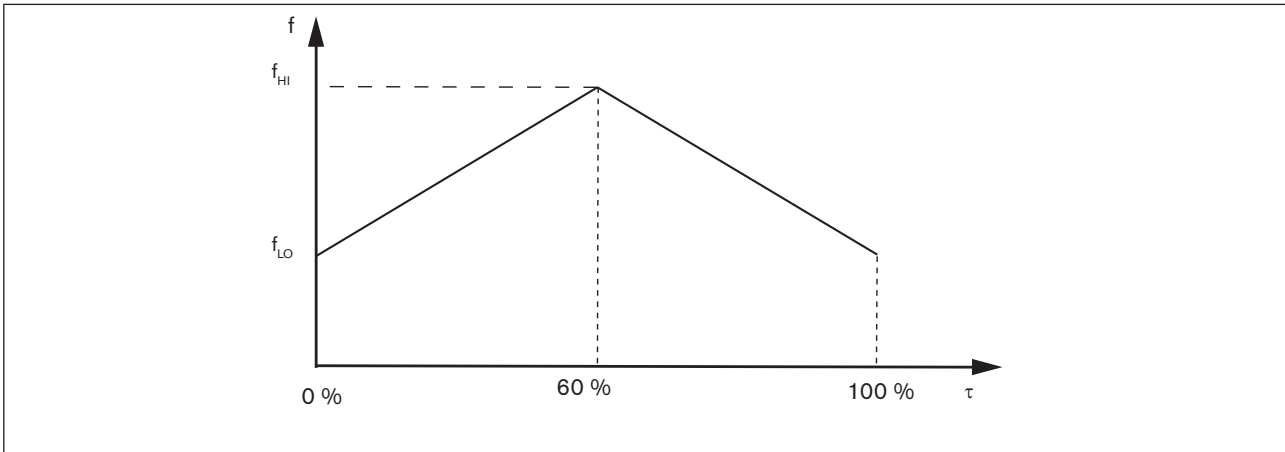

Figure 17: PWM frequency / pulse duty factor

The two limit frequencies of the PWM control (HI and LO) are set with the selection of the valve type. The frequency output actually varies within this range, depending on the working point.

The following values (see “Figure 17: PWM frequency / pulse duty factor”) were determined empirically from the behavior of a large number of individual devices of the corresponding type.

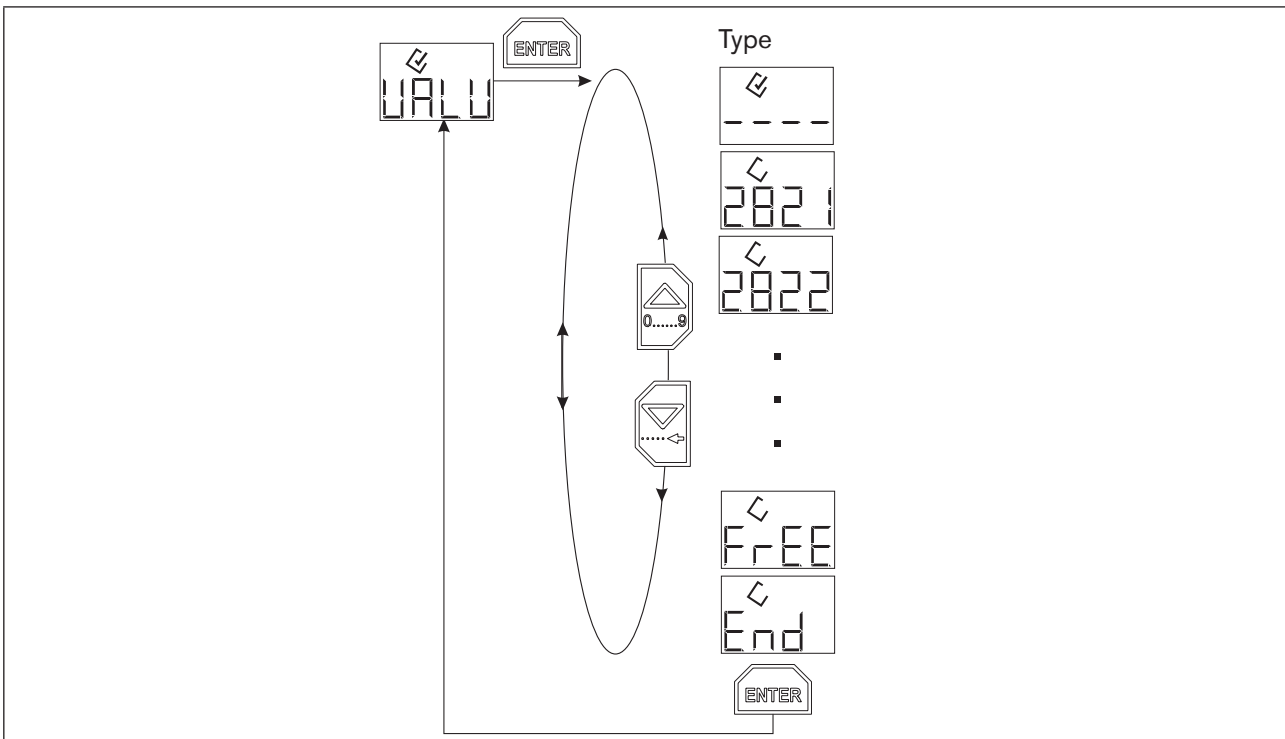

Figure 18: Limit frequencies for Bürkert valve types



Set values for PWM frequencies:

A table of PWM frequencies which are suitable for controlling the valve type can be found on the Bürkert homepage country.burkert.com → Typ 8605.

CAUTION!

Danger from wrong setting of the valve type.

If the selected valve type differs from the valve actually used whose coil has very different characteristics, the function of the valve can be severely impaired. When using the flat spring valve, Type 2822, the input of a wrong valve type can lead to irreparable device damage!

- **Always** set the valve type correctly. For this parameter, the value „----“ (no valve) is set as default value in the delivery condition. If no valve is selected, the coil remains de-energised.
- For types 2871, 2873, and 2875, variants for higher differential pressures are available. These variants can be selected in the valve type selection using the suffix “LO”. For the standard variants of these valve types 2871, 2873, and 2875, the suffix “HI” must be selected. You can find a table with the matching PWM frequencies for controlling the valve type on the Bürkert homepage country.burkert.com → Typ 8605.

! The choice of valves depends on the device type being used

Due to the scatter of the valve types with respect to friction characteristics and the relationship between sensitive control behavior and low hysteresis or low noise development and larger hysteresis, it can be advisable to deviate from the recommended PWM frequencies (see also chapter “9.3.3. VAdJ (Valve adjust) - Fine tuning of the valve frequency”).

9.3.3. VAdJ (Valve adjust) - Fine tuning of the valve frequency

In the menu VAdJ, the two frequencies defined with the selection of the valve type can be varied within certain limits. A reduction of the values is generally associated with:

- a reduction in the hysteresis of the valve characteristic,
- improved response sensitivity and
- an increased noise level.

If the frequencies are increased, the hysteresis increases and the response sensitivity becomes poorer. The control becomes slower and the noise level decreases.

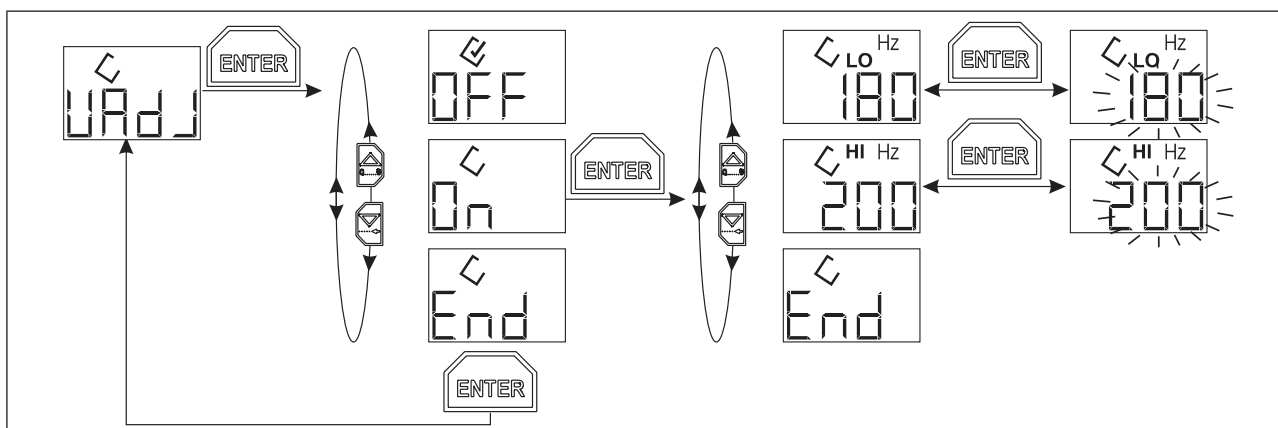

Figure 19: VAdJ (Valve adjust) - Fine tuning of the valve frequency

- **!** The following rule applies for the input of the frequency pairs: HI value > LO value
- In the menu item VALV, the HI and LO values are limited to an expedient range in relation to the valve type. No normal control behaviour can be expected outside this range.

9.3.4. Adj (Adjust) - Adaptation of the coil current

The working range of a proportional valve is defined by the coil current.

- **Lower current limit - LO [mA]**
Current value at which the valve just starts to open. This value corresponds to the nominal and actual value of 0 %. The setting range depends on the device version being used.
- **Upper current limit - HI [mA]**
Current value at which the valve just reaches the maximum flow rate. An increase in the coil current above the upper value does not result in any noticeable increase in the flow rate. This value corresponds to the nominal and actual value of 100 %. The setting range depends on the device version being used.

Current values outside the working range are irrelevant for a control. The range of the input standard signal (e. g. 0 to 10 V) is therefore set to the working range of the coil current (see chapter "7. Configuration and Function").

- For a given valve type (coil version), the working range depends on the nominal size of the valve and on the pressure ratios (inlet and return pressure) in the system. The setting has to be made under typical operating conditions.

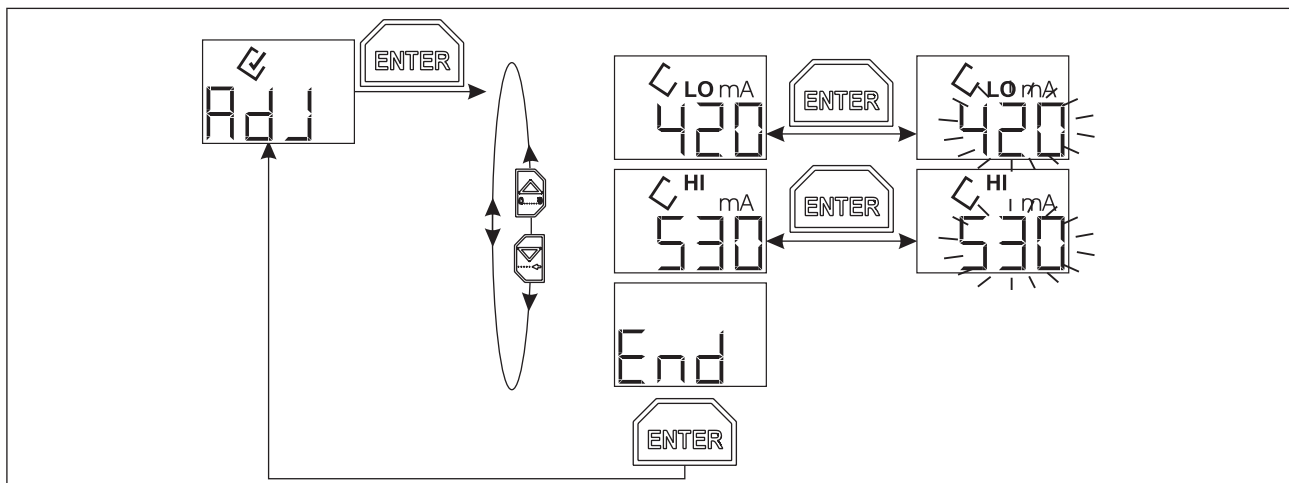

Figure 20: Adj (Adjust) - Adaptation of the coil current





- A flow indicator is necessary for the setting of the working range. Determine the start and the achievement of the maximum flow rate with this indicator.
- The absolute precision of the flow indicator is not crucial!

SETTING THE MINIMUM AND MAXIMUM COIL CURRENT

Start of flow

- Set the minimum coil current I_1 (Adj = LO mA) via the arrow keys so that the valve just starts to open.
- Start with a current value at which the valve is still reliably closed and increase the coil current with the arrow key until the flow indicator detects a flow for the first time.
- Reduce the coil current by a few mA with the key until the valve is reliably closed again.
- Confirm the minimum coil current I_1 with the -key.

Maximum flow rate

- Set the maximum coil current I_2 (Adj = HI mA) via the arrow keys so that the maximum flow rate is just achieved.
- Increase the coil current with the arrow key  until the maximum flow rate is reached and a further increase in the current does not result in a further increase in flow rate.
- Reduce the coil current with the arrow key  until the flow rate starts to drop noticeably again and confirm this value with the -key as the maximum coil current I_2 (Adj = HI mA).

Indicative current values, depending on the valve type

For the current values of the start of opening and the maximum flow rate there are default values for each valve type stored in the menu. These values are only indicated values depending on the nominal size of the valve and pressure ratio.

In the menu item ADJ the valve must be set to the nominal size of the valve and the current pressure.

For all direct-acting proportional valves (i. e. all types with the exception of Type 6223), the current value I_1 for the start of opening drops with increasing inlet pressure; with an increasing pressure drop through the valve, the value I_2 at which the maximum flow rate is achieved also decreases.

For the pilot-controlled valve, Type 6223, the current value for the start of opening increase with increasing inlet pressure; with an increasing pressure drop through the valve, the value I_2 also increases.

9.3.5. dELY (Delay) - Ramp function

The ramp time for attenuating sudden changes in the input signal can be entered separately for changes upwards and downwards.

- HI [s] - Ramp for a positive signal jump
The time indicated in seconds (0.1 to 10.0 s) relates to a change in set point from 0 % to 100 %.
- LO [s] - Ramp for a negative signal jump
The time indicated in seconds (0.1 to 10.0 s) relates to a change in set point from 100 % to 0 %.

With smaller changes in the input signal, the delay time corresponds to the set value multiplied by the size of the change in percent. For example, with a sudden change from 20 % to 70 %, it corresponds to exactly half the value set under HI in seconds. With a setting value of 0.0 s, the respective ramp function is deactivated.

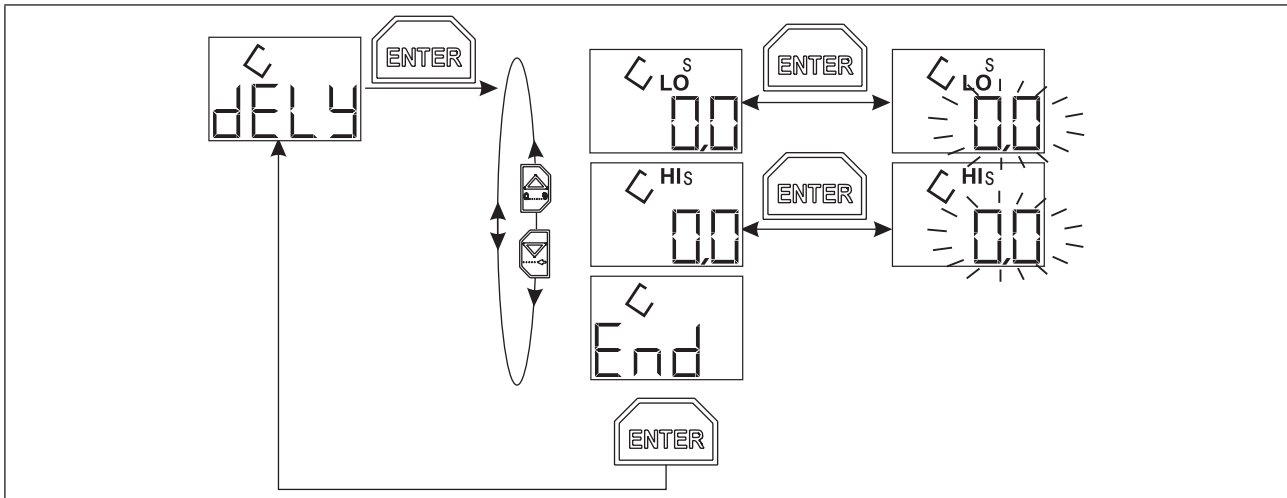

Figure 21: dELY (Delay) - Ramp function

9.3.6. Cut (Cut off) - Zero point cut off

In order to guarantee leak-tight closing of the valve, the valve is completely de-energised with input signals below the set limit (0.1 to 5.0 % of the set standard signal) when the zero point shutdown is active.

In addition to its control function, the valve can also take on the function of a cut-off valve.

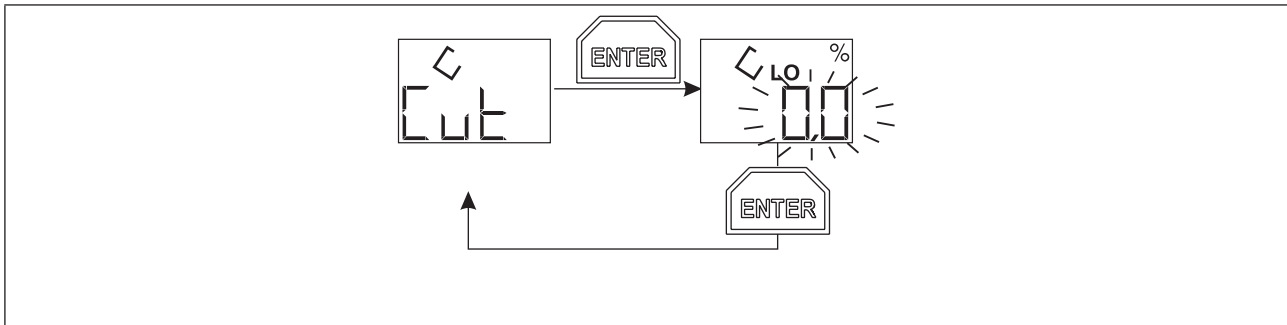

Figure 22: Cut (Cut off) - Zero point cut off



- With a set value of 0.0 %, the zero point cut-off is deactivated. Even at an input signal of 0 %, the valve no longer reliably shuts off the flow.
- The valve flow control restarts with a hysteresis of 0.5 %.
- The reactivation of the current controls starts as soon as the input signal is set to a value 0.5 % above the defined threshold value; i. e. there is a hysteresis of 0.5 % for the activation and deactivation of the cut off function
- The range of the input signal lying below the set threshold is no longer available for the current control and fluidic flow control

9.3.7. PArA (Parameter) - Controller setting

The controlled coil current cannot follow changes in the input signal at any random speed.

Different sets of control parameters are stored for the internal current control. The controller dynamics can therefore be set in three discrete steps between:

- very fast control with the probably occurrence of overswing behavior and
- slow control with a guaranteed elimination of overswing.

Set 1: slow

.....

Set 3: fast

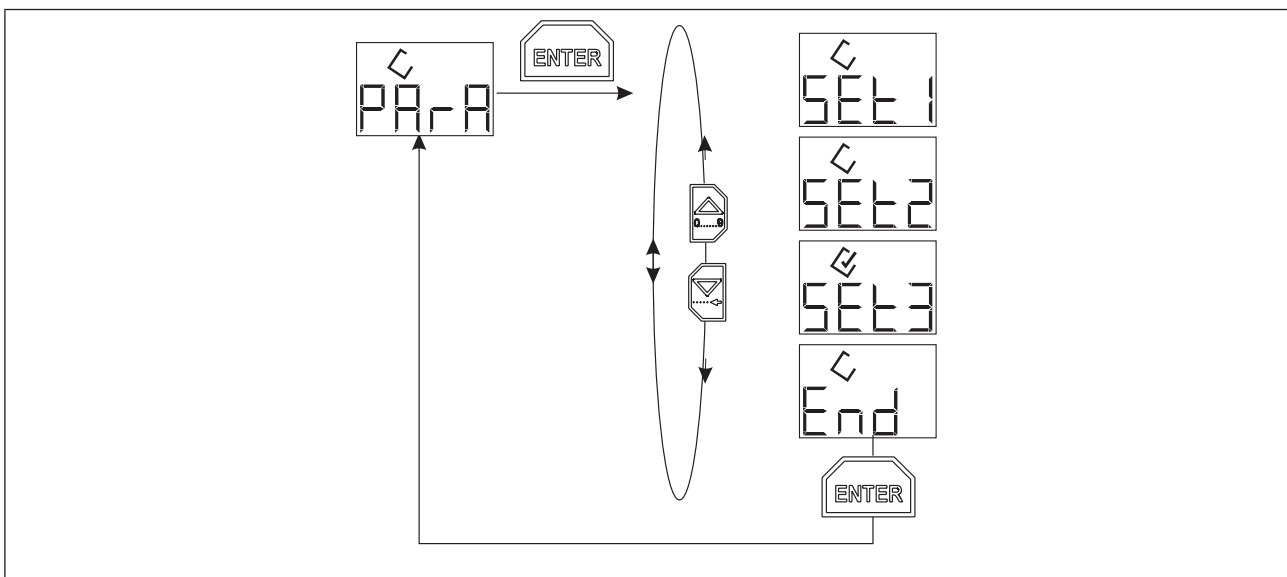

Figure 23: PArA (Parameter) - Controller setting

9.3.8. SPOS (Safe position) - Setting of the safety position

Input of the safety position (0.00 to 100.0 % or 200 %) that is controlled with a selected standard signal input of 4 to 20 mA and a drop below the 4 mA input signal.

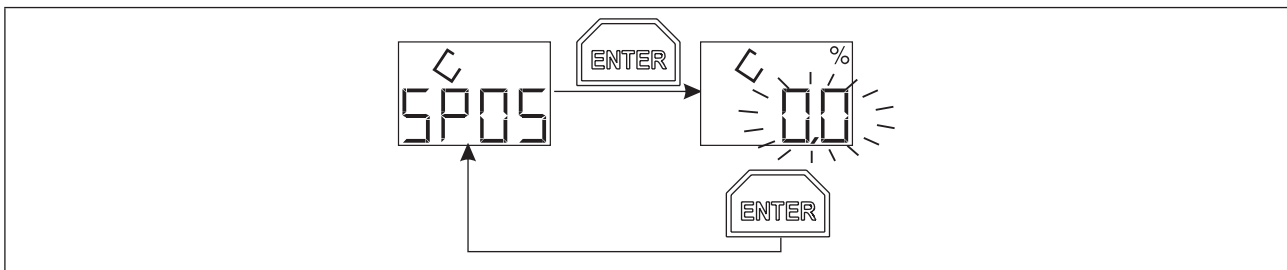

Figure 24: SPOS (Safe position) - Setting of the safety position



The standard signal 4 to 20 mA is the only one that permits a fault to be detected when the input value drops below 4 mA. In this case it is possible to define which current value is to be controlled (e. g. 50 %)

9.3.9. dAtA (Data) - Upload and Download of parameters between the operating unit and the basic device

This function is used for data transfer from one operating unit to several basic devices. After connecting the operating unit, the stored parameters can be transmitted to the basic device.

 This function is only available for the cable plug version.

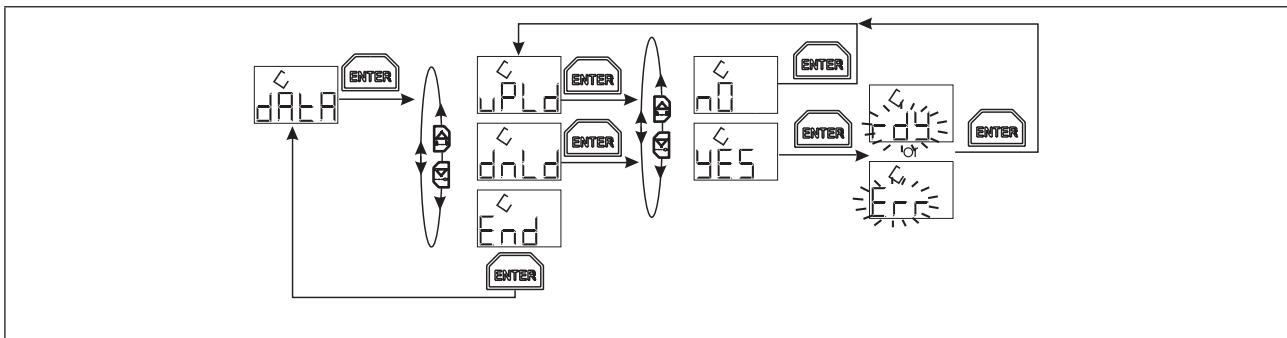

Figure 25: dAtA (Data)

uPLd (upload)

When upload is selected the parameters of the basic device are transferred to the operating unit. That means, that first the memory of the operating unit is cleared and then filled with all relevant data of the basic device. After that the operating unit displays „rdY“ (ready). If the data transfer failed „Err“ (error) is displayed.

dnLd (download)

When download is selected the parameters stored in the operating unit are transferred to the basic device. This is only possible, if the version of the data is the same as in the basic device (e. g. data transfer between a 200 - 1000 mA version and a 500 - 2000 mA version is not possible).

After that the operating unit displays “rdY”. If the data transfer failed “Err” is displayed.

9.3.10. END

To quit the respective menu level, select the menu item END with the arrow keys.

The settings made are saved on leaving the configuration menu.

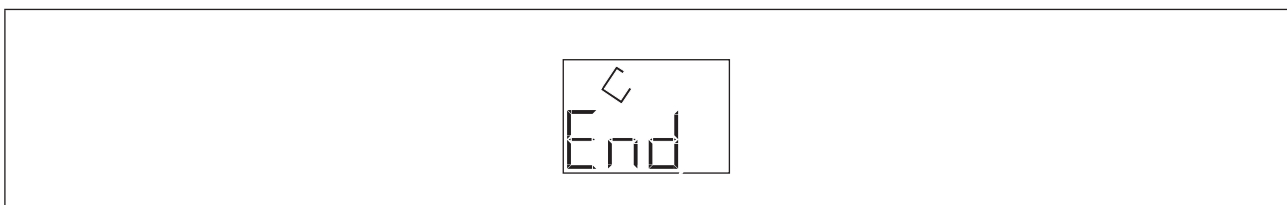

Figure 26: End

9.4. Factory Settings of the Control Electronics

Menu item	Factory setting	Comment
InP	0 ...10 V	Input signal 0 ...10 V selected
Out / VALV	- - - -	No valve selected
Out / VAdJ	OFF	Manual fine tuning of the valve frequency inactive
Out / AdJ	LO: 2 mA HI: 200 mA	These values are changed by a valve selection
deLY	LO: 0.0 s HI: 0.0 s	Ramp function inactive
Cut	LO: 2.0 %	Zero point cut-off active at 2 %
PArA	SEt2	Controller parameter set 2 selected
SPOS	0.0 %	Safety setting 0 % at an input signal below 4 mA (with selection of the 4 ... 20 mA input signal) selected

10. MAINTENANCE

10.1. Safety Instructions



WARNING!

Danger due to improper maintenance work!

Improper maintenance may result in injuries as well as damage to the device and the surrounding area.

- Maintenance work may be carried out by authorised technicians only and with the appropriate tools!

Danger due to unintentional activation of the equipment!

Unintentional activation of the equipment during maintenance and repair work may result in injuries and / or damage.

- Take appropriate measures to prevent the equipment from being unintentionally activated.

10.2. Service

When used in accordance with the instructions given in this operating manual, the Control Electronics Type 8605 is maintenance-free.

11. SPARE PARTS

CAUTION!

Danger due to incorrect accessories and replacement parts!

Incorrect accessories or unsuitable spare parts can result in injuries and in damage to the device and its surroundings.

- Use only original accessories and original spare parts from Bürkert.

11.1. Ordering charts: Device variants

Design	Cable plug with PG feed-through	Cable plug with PG feed-through without control unit	Cable plug with M12 connection	Cable plug with M12 connection without control unit	Cable plug with PG screw connection	Cable plug with PG feed-through without control unit	Cable plug with M12 connection	Cable plug with M12 connection without control unit	DIN-rail	DIN-rail	DIN-rail
Max. coil current range [mA]	200 - 1000	200 - 1000	200 - 1000	200 - 1000	500 - 2000	500 - 2000	500 - 2000	500 - 2000	40 - 220	200 - 1000	500 - 2000
Order no.:	316530	316521	316528	316522	316529	316523	316526	316525	316531	316532	316533
2824 24V DC									X	X	
2824 12V DC										X	
2833 24V DC	X	X	X	X						X	
2833 12V DC	X	X	X	X	X	X	X	X		X	X
2835 24V DC	X	X	X	X	X	X	X	X		X	X
2836 24V DC					X	X	X	X			X
2861 24V DC									X	X	
2861 12V DC										X	
2863 24V DC	X	X	X	X						X	
2863 12V DC	X	X	X	X	X	X	X	X		X	X
2865 24V DC	X	X	X	X	X	X	X	X		X	X
2871 24V DC									X	X	
2871 12V DC										X	
2873 24V DC	X	X	X	X						X	
2873 12V DC	X	X	X	X	X	X	X	X		X	X
2875 24V DC	X	X	X	X	X	X	X	X		X	X
6024 24V DC	X	X	X	X	X	X	X	X		X	X
6024 12V DC					X	X	X	X			X
6223 24V DC	X	X	X	X						X	
6223 12V DC					X	X	X	X			X

Variants for digital control (via bÜS/Communicator):

Variant	Max. coil current range [mA]	Order no.
Cable pulg with M12 connection without control unit	200-1000	355 655
Cable pulg with M12 connection without control unit	500-2000	364 714



If two current ranges of the control electronics are possible choose the lower one

11.2. Accessories

Accessories / Individual parts	Identification Number
Control unit for Type 8605 cable plug Rev.2	582 878
Control unit for Type 8605 cable plug Rev.3	20097278
M12 circular socket, 4-pin, angled (90°)	784 301
M12 circular socket with cable, 4-pin, A-coded, cable length: 5 m	918 038
Cover set (for operation without operating unit)	670 549

12. PACKAGING, TRANSPORT

NOTE!

Transport damages!

Inadequately protected equipment may be damaged during transport.

- During transportation protect the device against wet and dirt in shock-resistant packaging.
- Avoid exceeding or dropping below the allowable storage temperature.

13. STORAGE

NOTE!

Incorrect storage may damage the device.

- Store the device in a dry and dust-free location!
- Storage temperature. -40 °C ... +55 °C.

13.1. Decommissioning

Switch off the Control Electronics Type 8605 as follows:

- Depressurize the system.
- Switch off the power supply.
- Remove the Control Electronics.
- Keep the control electronics in the original packaging or in some other suitable packaging.

13.2. Restarting

Switch on the Control Electronics Type 8605 again as follows:

- Unpack the Control Electronics and allow it to reach room temperature before switching on again.
- Then proceed as described in chapter "[8. Installation](#)".

14. DISPOSAL

→ Dispose of the device and packaging in an environmentally friendly manner.

NOTE!

Damage to the environment caused by device components contaminated with media.

- Observe applicable regulations on disposal and the environment.



Note:

Observe national waste disposal regulations.

