

## OPTICAL FLOW RATE CONTROLLER

**8039**



Operating Instructions

© Bürkert 2000 - 2018 Subject to technical change  
00559849\_1809\_Ind\_E

MAN 1000370933 EN Version: AStatus: RL (released | freigegeben) printed: 14.05.2026

**bürkert**  
FLUID CONTROL SYSTEMS

# Table of contents

<b>1</b>	<b>SAFETY RECOMMENDATIONS</b> .....	<b>4</b>
1.1	Utilisation.....	4
1.2	Precautions at installation and commissioning.....	5
1.3	Conformity to standards and directives.....	5
1.4	Conformity to the pressure equipment directive .....	6
<b>2</b>	<b>DESCRIPTION</b> .....	<b>7</b>
2.1	Design.....	7
2.2	Measuring principle .....	7
2.3	Article numbers of electronic modules SE39 .....	8
2.4	Article numbers of accessory.....	8
<b>3</b>	<b>TECHNICAL DATA</b> .....	<b>9</b>
<b>4</b>	<b>INSTALLATION</b> .....	<b>12</b>
4.1	General recommendations .....	12
4.2	Mounting on the pipe .....	12
4.3	Electrical connection .....	13
4.3.1	Cable plugs.....	13
4.3.2	Version with NPN transistor output via EN 175301-803 connector.....	14
4.3.3	Version with PNP transistor output via EN 175301-803 connector.....	14
4.3.4	Version with NPN transistor output via EN 175301-803 connector.....	14
4.3.5	Version with PNP transistor output via EN 175301-803 connector.....	14

4.3.4	Version with both NPN and PNP transistor outputs via M12 connector .....	15
4.3.5	Version with PNP transistor output via M12 connector .....	16
4.3.6	Version with relay output.....	16
4.3.7	Version with relay and frequency outputs .....	17
<b>5</b>	<b>PROGRAMMING.....</b>	<b>18</b>
5.1	General recommendations .....	18
5.2	Functionalities .....	18
5.3	Programming keys .....	19
5.4	Default Configuration.....	19
5.5	Normal Mode .....	20
5.6	Possible switching modes of the 8039 .....	21
5.7	Calibration Mode.....	22
5.8	Simulation Mode .....	25
<b>6</b>	<b>MAINTENANCE.....</b>	<b>26</b>
6.1	Cleaning.....	26
6.2	Error messages.....	26
6.3	When a problem occurs .....	27
<b>7</b>	<b>ANNEX .....</b>	<b>28</b>
7.1	Connection examples with a 8039.....	28
7.2	Description of the label of controller 8039.....	31
7.3	Flow rate-velocity-DN diagrams.....	32



**Always respect the safety instructions marked by the symbol opposite as well as those included in the manual.**

## 1.1 Utilisation

The controller 8039 has only been designed to measure the flow rate of liquids that let through the infrareds.

There will be no manufacturer warranty for damages caused by unexpected handling or wrong usage of the device. The warranty on the device becomes invalid if any modification or change is made on the device.



**The device should only be installed and repaired by specialist staff. The user is not allowed to work on the cables inside the housing. If any difficulties may occur with the product during installation, please contact your nearest Bürkert sales office for assistance.**

## 1.2 Precautions at installation and commissioning

- When the device is powered and the cover is open, protection against electric shocks is not ensured.
- Always ensure the materials in contact with the medium to measure are chemically compatible with this medium.
- To clean the device, only use chemically compatible products.
- Always protect the device from electromagnetic perturbations, ultraviolet radiations and, when installed outside, from the effects of climatic conditions.



**When dismantling the controller from the pipe, take all the necessary precautions linked to the process.**

## 1.3 Conformity to standards and directives

The applied standards, which verify conformity with the EU directives, can be found on the EU-type examination certificate and/or the EU declaration of conformity (if applicable).

## 1.4 Conformity to the pressure equipment directive

The device conforms to Article 4, Paragraph 1 of the Pressure Equipment Directive 2014/68/EU under the following conditions:

- Device used on a pipe (depending on the maximum pressure, the DN of the pipe and the fluid)

Type of fluid	Conditions
Fluid group 1, Article 4, Paragraph 1.c.i	$DN \leq 25$
Fluid group 2, Article 4, Paragraph 1.c.i	$DN \leq 32$ or $PS \times DN \leq 1000$
Fluid group 1, Article 4, Paragraph 1.c.ii	$DN \leq 25$ or $PS \times DN \leq 2000$
Fluid group 2, Article 4, Paragraph 1.c.ii	$DN \leq 200$ or $PS \leq 10$ or $PS \times DN \leq 5000$

## 2 DESCRIPTION

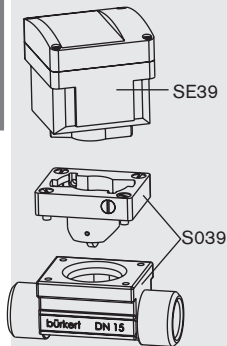

### 2.1 Design

The flow rate controller 8039 is made up of an electronic module SE39 and a fitting S039 with integrated paddle-wheel. It may switch a solenoid valve, activate an alarm or establish a control loop.

Furthermore, the version with a frequency output makes it possible to transmit the paddle-wheel rotation speed (2 pulses/paddle-wheel turn) directly to a PLC.

The switching point can be adjusted by means of the three keys located under the display.

The electrical connection is carried out via an EN175301-803 connector and/or a steerable M12 multipin connector.

### 2.2 Measuring principle

The controller 8039 detects the rotation of the S039 fitting paddle-wheel. The latter produces pulses whose frequency is proportional to the flow rate ( $f = K \cdot Q$ , where  $f$  is the frequency in Hz,  $K$  the  $K$  factor specific to each fitting in pulses/l and  $Q$  the flow rate in l/s).



**The flow rate is only taken into account if the medium flows in the direction indicated by the arrow marked on the housing.**

### 2.3 Article numbers of electronic modules SE39

Power supply	Output	Electrical connection	Article number
12-30 VDC	NPN	EN 175301-803 connector	440378
12-30 VDC	PNP	EN 175301-803 connector	440379
12-30 VDC	PNP	M12 connector	449556
12-30 VDC	NPN and PNP	M12 connector	440377
12-30 VDC	Relay	EN 175301-803 and M12 connectors	440382
12-30 VDC	Relay and frequency	EN 175301-803 and M12 connectors	447806

### 2.4 Article numbers of accessory

Accessory	Article number
5-pin M12 cable plug, to be wired	917116
5-pin M12 cable plug, moulded on a shielded cable (2 m)	438680
EN175301-803 cable plug (type 2508) with cable gland	438811
EN175301-803 cable plug (type 2509) with NPT 1/2" reduction	162673

### 3 TECHNICAL DATA

#### General features

Pipe diameter	DN6 to DN50 (1/4" to 2"); determine the appropriate diameter using the flow rate-velocity-DN diagrams (see Annex)
Fluid temperature	max. 100 °C
Fluid pressure	depends on the S039 fitting (see the corresponding fitting manual)
Fluid viscosity	max. 300 cSt
Rate of solid particles	max. 1%
Measuring range	0,3 m/s to 10 m/s (1.0 to 32 fps), 0.3 m/s (1.0 fps) corresponds to a flow rate of 0,5 l/min (0.2 gpm) in a DN6 (1/4") fitting.
Measurement deviation	- with standard K-factor of the fitting: $\pm 3\%$ of the measured value * - with K-factor determined with a teach-in procedure: $\pm 1\%$ of the measured value * (at the value of the teach-in flow rate)
Linearity	$\pm 0.5\%$ of the full scale (10 m/s)
Repeatability	$\pm 0.4\%$ of the measured value *
Measuring element	paddle-wheel of the S039 fitting
Protection rating (housing)	IP 65, cable plugs being plugged-in and tightened

\* Determined in the following reference conditions: medium = water, water and ambient temperatures 20 °C, min. upstream and downstream distances respected, appropriate pipe dimensions

**Electrical features**

Installation class	2
(overvoltage class)	
Insulating strength	2300 VAC
Power supply	12-30 VDC
Current consumption	
Version with PNP output	max.750 mA + consumption of the load, if the PNP output is connected max. 50 mA + consumption of the load, if the PNP output is not connected
Version with relay output	max. 80 mA, without load
Protection against polarity reversal	yes
Transistor output	NPN and/or PNP, open collector, max. 700 mA, NPN output: 0,2-30 VDC and PNP output: supply voltage (see example in the Annex)
Relay output	250 VAC, max. 3 A or 30 VDC, max. 3 A; programmable
Frequency output	NPN transistor, open collector, max. 700 mA, 0,2-30 VDC, not programmable
Protection against short-circuits	yes for the transistor output
Type of cable recommended	shielded, wire section between 0.14 and 0.5 mm <sup>2</sup>

### 3 TECHNICAL DATA

#### Electrical connection

NPN version

EN 175301-803 cable plug (supplied)\*\*

PNP version

EN 175301-803- (supplied)\*\* or 5-pin M12 (not supplied) cable plug

NPN/PNP version

5-pin M12 cable plug (not supplied)

Relay (+ frequency) version

EN 175301-803 (supplied)\*\* and 5-pin M12 (not supplied) cable plugs

\*\* EaseOn with cable plug type 2511 on request

#### Materials

Housing

polycarbonate, fiber glass reinforced

Front plate

polyester and polycarbonate

Fitting S039

brass

Sensor holder / paddle-wheel

PVDF

Fitting axis / bearings

ceramic

O-rings

FKM standard (EPDM as an option)

#### Environment

Ambient temperature

0 to +60 °C

Relative humidity

< 80%, non condensing

#### Dimensions

Refer to the technical data sheet related to the device at: [www.burkert.com](http://www.burkert.com)



### 4.1 General recommendations

- Always check the chemical compatibility of the materials the controller is made of with the products it may be in contact with, for instance: alcohols, strong or concentrated acids, aldehydes, bases, esters, aliphatics, aromatics, ketones, aromatics or halogenated hydrocarbons, oxidizing agents and chlorinated products.
- Avoid installing the controller near industrial lighting which may disturb the optical sensor (mercury halide lamps for example).

For more information, please contact your Bürkert sales office.

### 4.2 Mounting on the pipe

The controller 8039 includes an S039 fitting for installation on a pipe. Install the 8039 on the pipe so that the arrow on the housing indicates the direction of the flow.

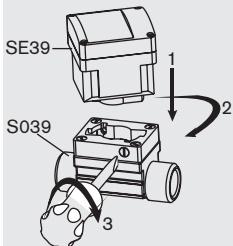

### 4.3 Electrical connection

Always ensure the power supply is switched off before working on the device. All the cable plugs must be plugged out. Use:

- a shielded cable with an operating temperature  $> +80\text{ }^{\circ}\text{C}$ .
- a high quality voltage supply (filtered and regulated).



**Install the following security devices:**

- for the power supply: a 1-A fuse
- for the relay: a max. 3-A-fuse and a circuit breaker (depending on the application).

#### 4.3.1 Cable plugs

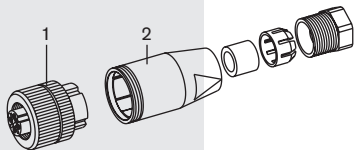

#### Multipin M12 cable plug (not supplied)

- Loosen threaded ring [1]
- Remove part [2] from the connector.
- Wire according to pin assignment (see 4.3.4, 4.3.5, 4.3.6 or 4.3.7)

#### 2508 cable plug (supplied)

- To open the plug, unfasten screw [1].
- Remove part [3] from part [2].
- Unscrew cable gland [5].
- Insert cable into part [2] via cable gland.
- Wire part [3] (see 4.3.2, 4.3.3, 4.3.6 or 4.3.7).
- Replace part [3] into part [2], by 90°-steps.
- Tighten cable gland [5]. Place gasket [4] between the cable plug and the fixed connector of the controller and plug the 2508 onto the fixed connector.
- Tighten screw [1] to ensure tightness and correct electrical contact.

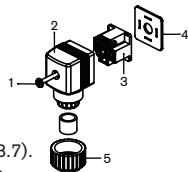

## 4 INSTALLATION

## Flow rate controller 8039

### 4.3.2 Version with NPN transistor output via EN 175301-803 connector

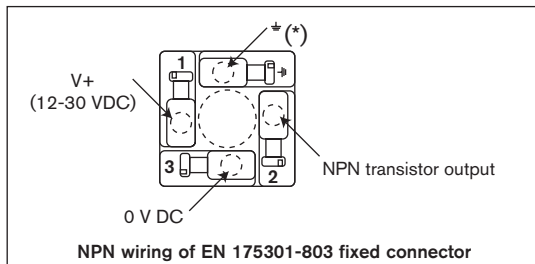
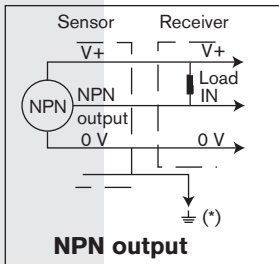

### 4.3.3 Version with PNP transistor output via EN 175301-803 connector

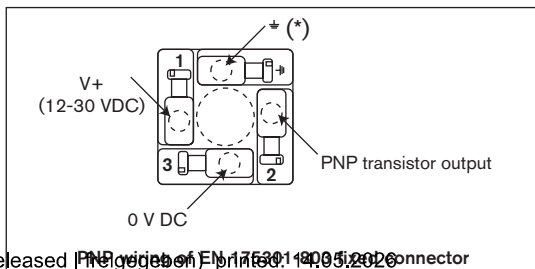
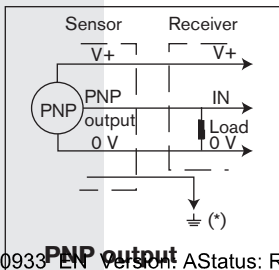

### 4.3.4 Version with both NPN and PNP transistor outputs via M12 connector

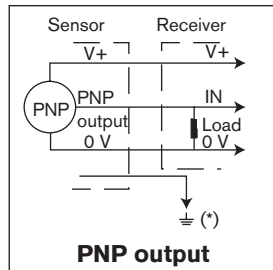
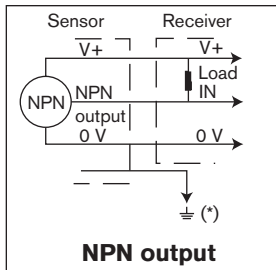

The controller is fitted with a steerable M12 fixed connector:

Unfasten counternut. Turn the fixed connector to the right position, but by max. 360° to avoid twisting of the cables inside the housing. Fasten counternut using the appropriate tool while maintaining the fixed connector in the right position.

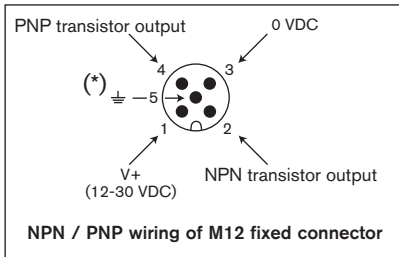

Pin number of the M12 cable available as an accessory (article number 438680)	Wire colour
1	brown
2	white
3	blue
4	black
5	grey

(\*) Functional earth

## 4 INSTALLATION

## Flow rate controller 8039

### 4.3.5 Version with PNP transistor output via M12 connector

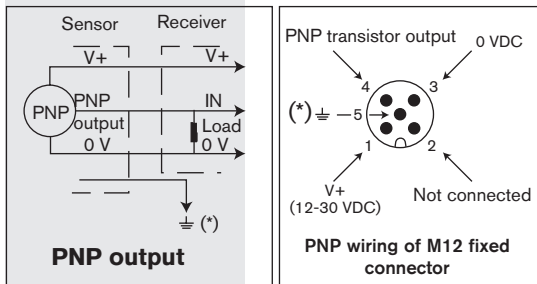

Pin number of the M12 cable available as an accessory (article number 438680)	Wire colour
1	brown
2	white
3	blue
4	black
5	grey

The controller is fitted with a steerable M12 fixed connector:

Unfasten counternut. Turn the fixed connector to the right position, but by max. 360° to avoid twisting of the cables inside the housing. Fasten counternut using the appropriate tool while maintaining the fixed connector in the right position.

### 4.3.6 Version with relay output

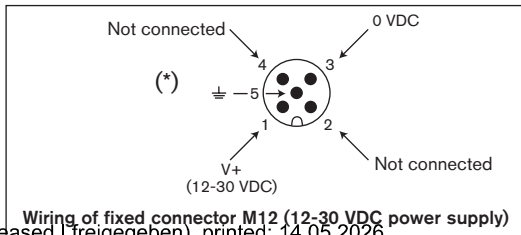
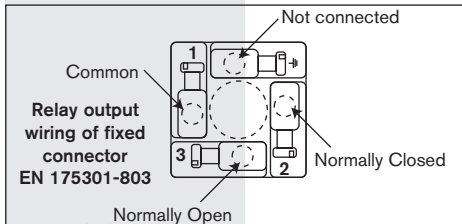

### 4.3.7 Version with relay and frequency outputs

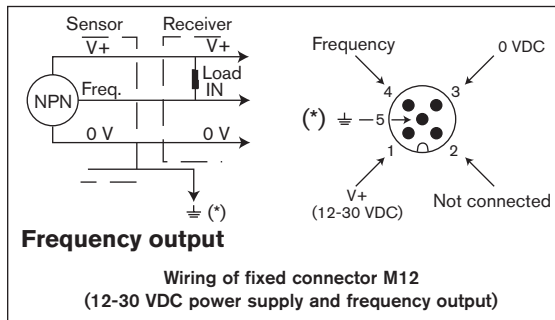
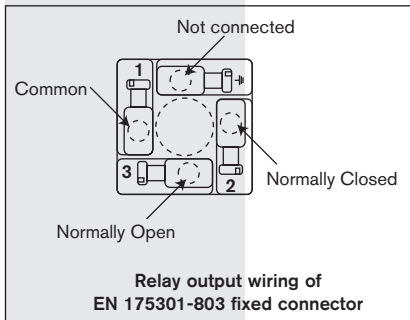

The controller is fitted with a steerable M12 fixed connector:

Unfasten counternut. Turn the fixed connector to the right position, but by max. 360° to avoid twisting of the cables inside the housing. Fasten counternut using the appropriate tool while maintaining the fixed connector in the right position.

#### Operating safety

When the voltage at the relay terminals is higher than 24 V and the cable plugs are not correctly plugged-in and tightened, there is a risk to electrocute yourself.

Always check all the cable plugs before powering the device to ensure the good operating of the device.



(\*) Functional earth

## 5.1 General recommendations



Keep in mind that the process may be influenced by all the parameter settings you make. Fill-in the table [page 24](#) with your settings of the controller.

Frequency output cannot be programmed.

## 5.2 Functionalities

The device has three operating modes :

### Normal Mode

Display of the measured flow rate and the switching thresholds programmed. From the Normal mode, you can access the Calibration and Simulation modes.

### Calibration Mode

Access to the programming of all the parameters (unit, K-factor, calibration through the „Teach-in“ feature, output, filter, bargraph). From the Calibration Mode, you can go back to the Normal Mode.

### Simulation Mode

Entering a theoretical flow rate value to test the configuration programmed in the Calibration Mode. From the Simulation Mode, you can go back to the Normal Mode.

### 5.3 Programming keys

To display the measured value and the configuration (8 characters: 4 numeric et 4 alphanumeric charact.)

Modifies the displayed value (0...9) ;  
To go to the previous function.

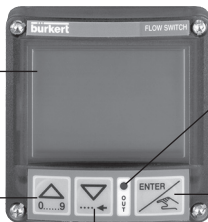

To indicate the status of the switching output (red LED)

To validate a function;  
To validate the entered data.

To select the character;  
To go to the next function.

### 5.4 Default Configuration

At the first powering up, the configuration of the controller 8039 is as follows:

Flow rate unit:	l/s
K factor	1
Output:	hysteresis, inverted
OLO:	0
OHI:	0
DEL:	0 s
filtre:	2
BGLO:	0
BGHI:	0
EXT	No (feature not used)

## 5.5 Normal Mode

To display the measured flow rate.

Unit of the measured flow rate.

To go back to the previous function.

To display the high threshold value (O HI).

To go to the next function.

To display the low threshold value (O LO).

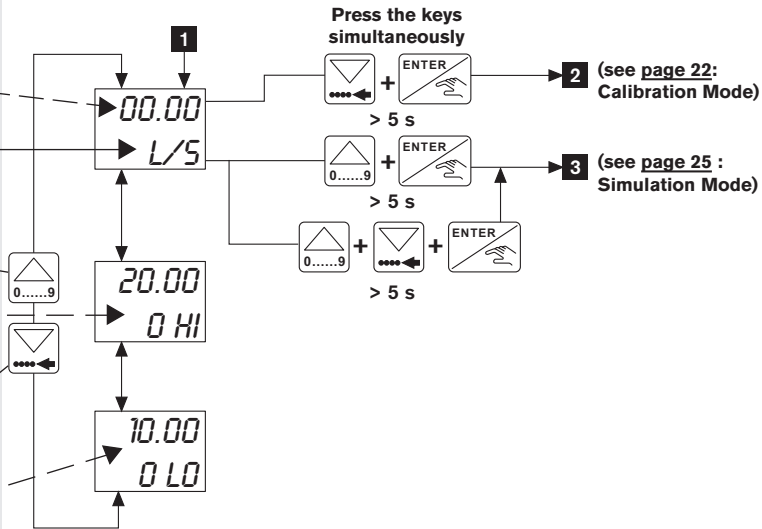

## 5.6 Possible switching modes of the 8039

### Hysteresis Mode

The change of state occurs when a threshold is detected (increasing flow rate: high threshold (OHI) to be detected, decreasing flow rate: low threshold (OLO) to be detected).

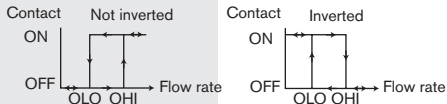

### Window Mode

The change of state occurs when any threshold is detected.

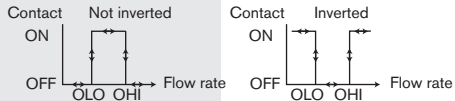

The delay (DEL) is set for the both switching thresholds. The switching only occurs when either threshold value (OHI - OLO) is exceeded for a duration higher than the DEL delay.

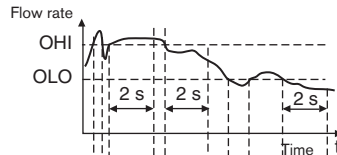

### Hysteresis Mode

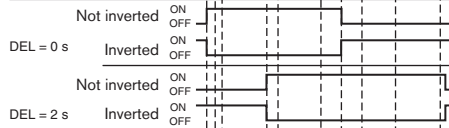

### Window Mode

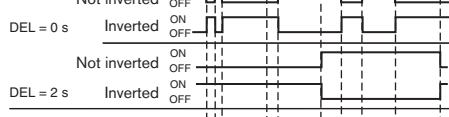

Switching examples of the 8039 depending on the flow rate and the switching mode chosen



**To choose :**

- the switching mode of the output (Hysteresis or Window, see p. 21)
- the low (O LO) and high (O HI) switching thresholds
- whether the switching mode is inverted or not (INV, see p. 21)
- the delay before switching (DEL, in seconds)

**To choose** the filtering level (FILT) of the displayed flow rate; «0» means "all the flow rate variations are displayed", «9» smoothes the displayed flow rates at the most.

**To define** the min. (BG LO) and max. (BG HI) values of the bargraph at the bottom of the display.

**Feature EXT** not used.

**To return** (END) to the display of the flow rate in the Normal mode.

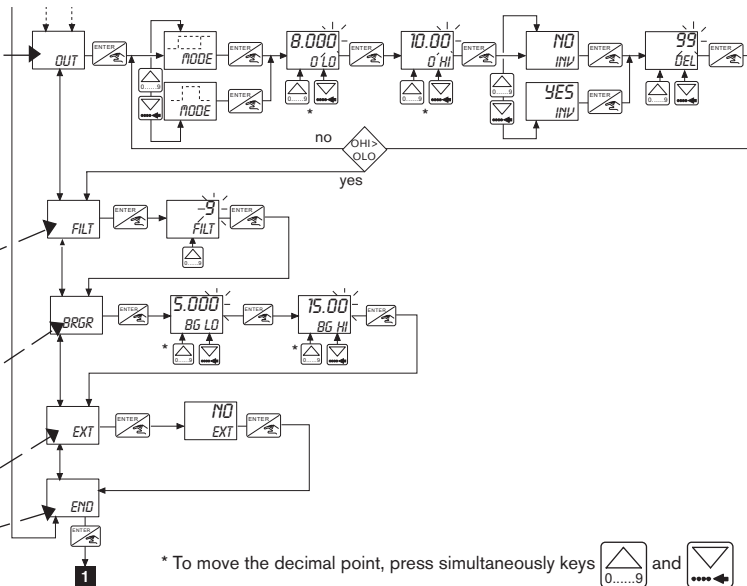

## 5 PROGRAMMING

## Flow rate controller 8039

Configuration of the 8039: Fill-in the table with the parameters set in the Calibration mode.

Unit	K-factor	Switching mode		Thresholds		Inverted		Delay	Filtre	Bargraph		Datum	Signature
UNIT	K FAC	HYST. *	WIN.**	O LO	O HI	YES	NO	DEL (s)	FILT	BG LO	BG HI		

\* **Hysteresis mode:**



\*\* **Window mode:**



## 5.8 Simulation Mode

**Feature** EXT not used.

**To go back** to the previous function.

**To go to** the next function.

**To test** the switching thresholds after entering a flow rate value (SIM) and PRESSING THE ENTER KEY.

**To return** (END) to the display of the flow rate in the Normal mode.

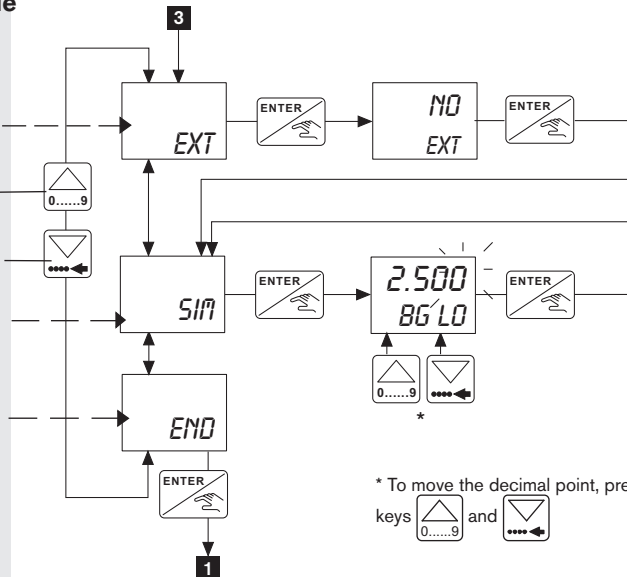

\* To move the decimal point, press simultaneously keys  and 

### 6.1 Cleaning

The controller 8039 can be cleaned with water or any solution compatible with the materials the device is made of.

For more information, please contact your Bürkert sales office.

### 6.2 Error messages

Message displayed	Description	What to do
ERR 0	Calibration data is lost. Reading error: the process is stopped.	Press the ENTER key to go back to the Normal mode. The device has returned to its default configuration: the device must be calibrated again. If the message appears frequently, send the device back to your Bürkert sales office.
ERR 1	Calibration data cannot be saved. Write error: the process is stopped.	Press the ENTER key to go back to the Normal mode. The device displays the configured data; BUT this data has not been saved: the device must be calibrated again. If the message appears frequently, send the device back to your Bürkert sales office.
ERR 2	The calibration parameters cannot be accessed. Menu reading error: the process goes on operating.	Press the UP and DOWN keys under the display to scroll through the menus. If the message appears frequently, send the device back to your Bürkert sales office.

### 6.3 When a problem occurs

If the display shows a flow rate equal to zero, do the following:

- ensure the controller has been installed so that the arrow on the housing shows the direction of the flow.
- ensure the K factor is different from 0 (menu CALIB, KFAC function).
- separate the SE39 from the S039 and pass your finger rapidly and several times in a row under the sensor to simulate the rotation of the paddle-wheel.
- ensure the paddle-wheel is clean.

If the display still shows a flow rate equal to zero, send the device back to your Bürkert sales office.

**NPN connection:  
controller 8039  
(NPN/PNP version)  
to a PLC.**

### 7.1 Connection examples with a 8039

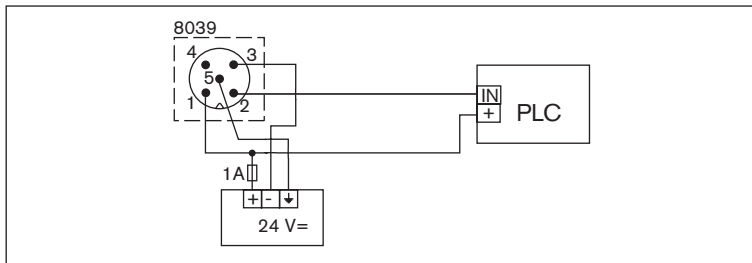

**PNP connection:  
controller 8039  
(NPN/PNP version)  
to a Top Control  
8631.**

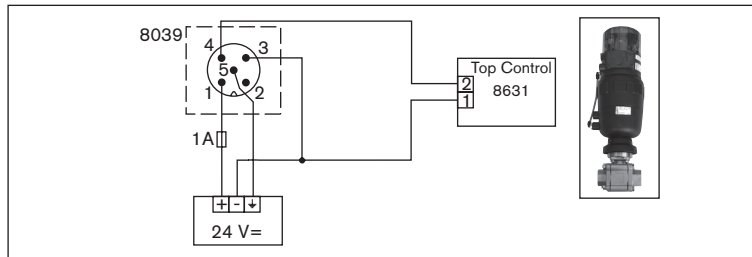

**NPN connection:  
controller 8039  
(NPN/PNP version)  
to a solenoid valve  
6014.**

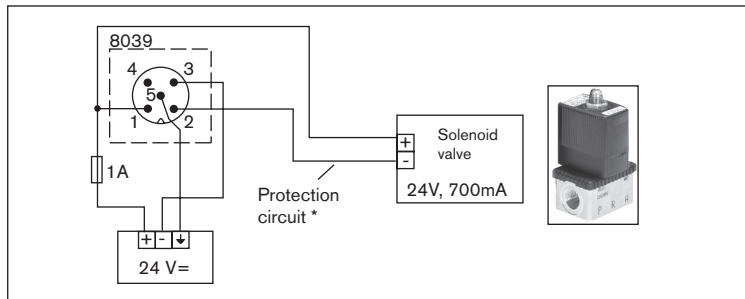

**PNP connection:  
controller 8039  
(NPN/PNP version)  
and a solenoid  
valve.**

\* Protection must be installed by the user depending on the load, for instance, a connector EN 175301-803 with integrated varistor.

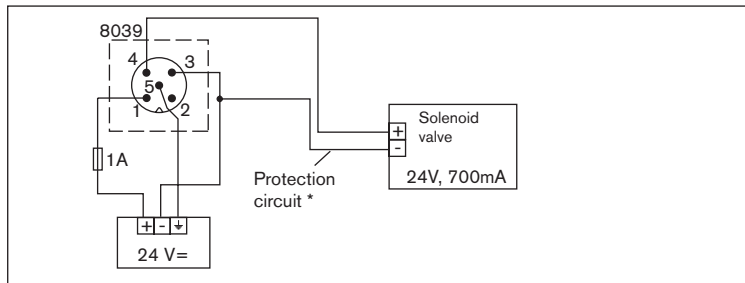

**NO connection,  
Normally Open:  
controller 8039  
(relay version)  
and a solenoid valve.**

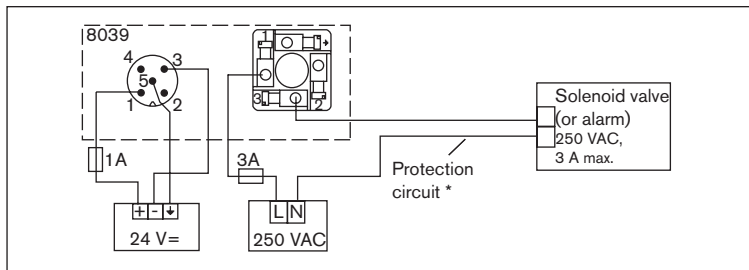

**NC connection,  
Normally Closed:  
controller 8039  
(relay version)  
and a solenoid valve.**

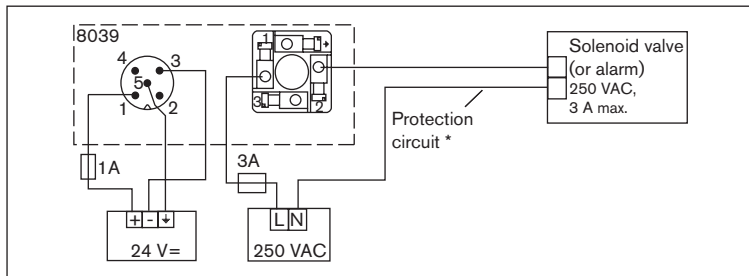

\* Protection must be installed by the user depending on the load, for instance, a connector EN 175301-803 with integrated varistor.

## 7.2 Description of the label of controller 8039

1. Measured quantity and type of controller
2. Power supply
3. Output characteristics
4. Serial number
5. Conformity marking
6. Protection class: protective insulation
7. Manufacturer code
8. Article number
9. Optical sensor

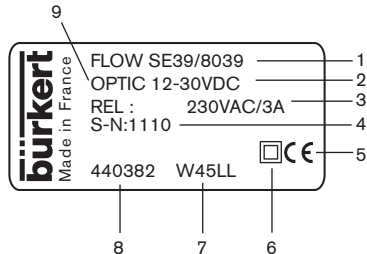

### 7.3 Flow rate-velocity-DN diagrams

The diagrams make it possible to determine the appropriate DN for the pipe and fitting, depending on the fluid velocity and the flow rate.



The names of the following norms have changed in the Operating Instructions:

- for the welding ends, norm BS 4825 is renamed BS 4825-1.
- for the welding ends, norm DIN 11850 is renamed DIN 11850 series 2.
- for the clamp connections, norm BS 4825 is renamed BS 4825-3.
- for the clamp connections, norm DIN 32676 is renamed DIN 32676 series A.



The norm for the clamp connections ISO 2852 has been suppressed.



The norms for the weld end connections DIN 11866 series C, DIN 11866 series A and EN 10357 series A have been added.

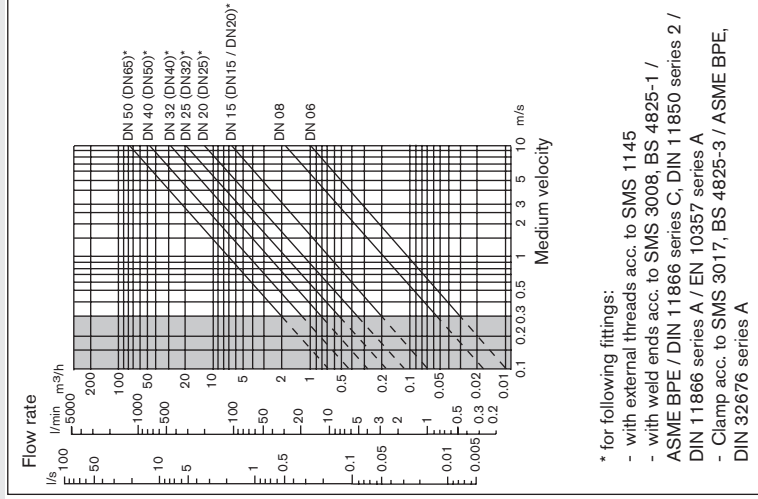

## 7 ANNEX

## Flow rate controller 8039

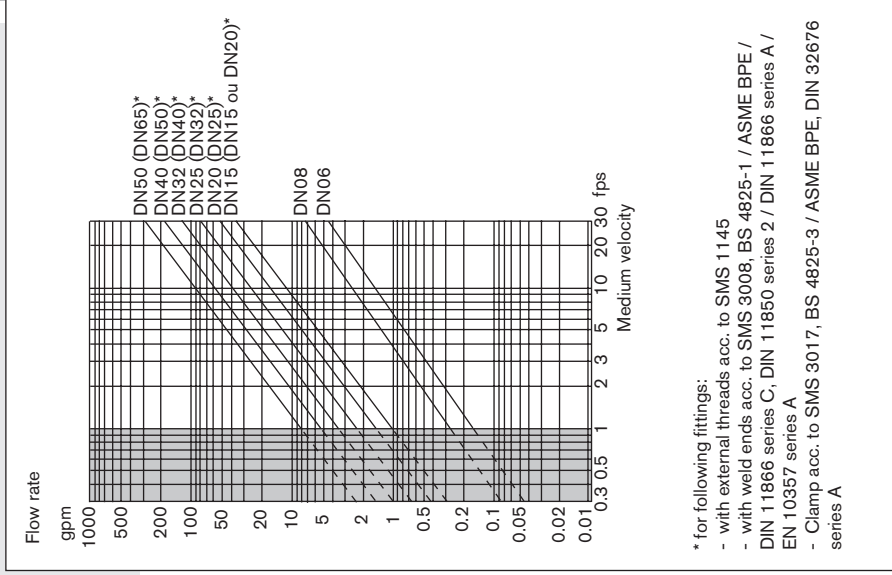

**NOTES**

