

Type 2920, 2921, 2960, 2961

2/2 way valve, manually operated

2/2-Wege-Ventil, handbetätigt

Vanne à 2/2 voies, actionnement manuel



Operating Instructions

Bedienungsanleitung

Manuel d'utilisation

We reserve the right to make technical changes without notice.
Technische Änderungen vorbehalten.
Sous réserve de modifications techniques.

© Bürkert Werke GmbH & Co. KG, 2023

Operating Instructions 2311/00_EU-ML_00815454 / Original DE

1	OPERATING INSTRUCTIONS	4	8	DISASSEMBLY	16
1.1	Symbols.....	4	9	MAINTENANCE	16
1.2	Definition of terms	4	9.1	Maintenance work	16
2	INTENDED USE	5	9.2	Cleaning	17
3	BASIC SAFETY INSTRUCTIONS	5	9.3	Faults	17
4	GENERAL NOTES	7	10	SPARE PARTS	17
4.1	Contact addresses	7	10.1	Order spare parts in eShop	17
4.2	Warranty	7	11	TRANSPORTATION, STORAGE, DISPOSAL	18
4.3	Information on the Internet	7			
5	PRODUCT DESCRIPTION	7			
5.1	Structure and description.....	7			
5.2	Variants.....	8			
5.3	Function.....	9			
5.4	Product identification	11			
6	TECHNICAL DATA	11			
6.1	Standards and directives.....	11			
6.2	Operating conditions.....	11			
7	INSTALLATION	13			
7.1	Notes for correct installation	13			
7.2	Installing valve body	13			
7.3	Install the actuator on devices with a welded connection.....	14			
7.4	Set stroke limit.....	14			
7.5	Lock handwheel	15			

1 OPERATING INSTRUCTIONS

The operating instructions describe the entire life cycle of the device. Keep these instructions ready to hand at the operating site.

Important safety information.

- ▶ Read these instructions carefully.
- ▶ Above all, observe the safety instructions, intended use and usage conditions.
- ▶ Persons who work on the device must read and understand these instructions.

1.1 Symbols



DANGER

Warning of an immediate danger.

- ▶ Failure to comply will result in death or serious injury.



WARNING

Warns of a potential danger.

- ▶ Failure to observe these warnings may result in serious injuries or death.



CAUTION

Warns of a potential hazard.

- ▶ Failure to comply with these instructions may result in moderate or minor injury.

NOTE

Warns of damage.



Important tips and recommendations.



Refers to information in these operating instructions or in other documentation.

- ▶ Highlights instructions to avoid a danger.

→ Highlights a procedure which you must carry out.

1.2 Definition of terms

Term	Definition for these instructions
Device	2/2 way valve, manually operated type 2920, 2921, 2960 and 2961
Ex area	Potentially explosive atmosphere
Explosion protection approval	Approval in potentially explosive atmosphere
PS	Maximum permissible pressure

2 INTENDED USE

The 2/2 way valve, manually operated type 2920, 2921, 2960 and 2961 is designed to control the flow of media. The authorised media are listed in chapter “Technical data”.

- ▶ Use the device only as intended. Non-intended use of the device may be dangerous to people, nearby equipment and the environment.
- ▶ Prerequisites for safe and trouble-free operation are correct transportation, correct storage, installation, start-up, operation and maintenance.
- ▶ To use the device, observe the permitted data, operating conditions and usage conditions. These specifications can be found in the contract documents, the operating instructions and on the Type label.
- ▶ Use the device only in conjunction with third-party devices and components recommended or approved by Bürkert.
- ▶ Only use equipment that is approved for this type of potentially explosive area. These devices are identified by a separate “Ex” type label. Before use, note the information on the separate Ex type label and the Ex additional instructions or the separate Ex operating Instructions.
- ▶ Protect device from environmental influences (e.g. radiation, air humidity, vibrations, fumes). If you have any questions, contact your Bürkert sales department.

3 BASIC SAFETY INSTRUCTIONS

These safety instructions do not take into account any unforeseen circumstances or events that occur during installation, operation and maintenance. The operator is responsible for observing the location-specific safety regulations, also with reference to personnel.



Risk of injury due to high pressure and escaping medium.

- ▶ Switch off the pressure before working on the device or system. Vent or empty the lines.

Danger of bursting in case of overpressure.

If the device bursts, the medium may cause injuries, burns or scalds.

- ▶ Do not exceed the maximum medium pressure. Observe specifications on the type label.
- ▶ Observe allowable temperatures.

Danger of burns and risk of fire.

- ▶ Only touch the device when wearing protective gloves.
- ▶ Keep the device away from highly flammable substances and media.

Discharge of medium if packing gland worn.

- ▶ Inspect relief bore for any medium leakages.
- ▶ If the medium is hazardous, secure the area around the leakage to prevent risks.

Risk of crushing by mechanically powered parts.

The upwards and downwards movement of the device means there is a risk of crushing.

- ▶ Do not reach into the openings of the valve body.

Danger due to loud noises.

Depending on the usage conditions, the device may generate loud noises and vibrations. Particularly with valve bodies bigger than DN65, particular attention must be taken to make sure that the devices are not operated in noisy environments with vibrations. Precise information on the likelihood of loud noises is available from the relevant sales department.

- ▶ Wear hearing protection when in the vicinity of the device.

To avoid injury, observe the following:

- ▶ Do not make any changes to the device and do not subject it to mechanical stress.
- ▶ Only trained technicians may perform installation and maintenance work.
- ▶ Perform installation and maintenance work using suitable tools only.
- ▶ Only tighten the device by hand when closing it, do not use any tools or aids. Too much tightening may damage the device.
- ▶ Heavy equipment must only be transported, assembled and disassembled with the help of a second person whilst using suitable apparatus.

- ▶ The process must be restarted in a defined or controlled manner after an interruption in the power supply or pneumatic supply.
- ▶ Operate the device only when it is in perfect condition and in accordance with the operating instructions.
- ▶ For applications planning and operation of the device, observe the plant-specific safety regulations.
- ▶ Only the media listed in chapter [“Technical data”](#) should be fed into the port connections.
- ▶ Observe the general rules of technical equipment.
- ▶ The plant owner is responsible for the safe operation and handling of the plant.

4 GENERAL NOTES

4.1 Contact addresses

Germany

Bürkert Fluid Control Systems
 Sales Centre
 Christian-Bürkert-Str. 13-17
 D-74653 Ingelfingen
 Tel. +49 (0) 7940 - 10 91 111
 Fax +49 (0) 7940 - 10 91 448
 E-mail: info@burkert.com

International

The contact addresses can be found on the back pages of the printed operating instructions.

They are also available online at: country.burkert.com

4.2 Warranty

A precondition for the warranty is that the device is used as intended in consideration of the specified usage conditions.

4.3 Information on the Internet

Operating instructions and data sheets for Type 2920, 2921, 2960 and 2961 can be found on the Internet at:

www.country.burkert.com

5 PRODUCT DESCRIPTION

5.1 Structure and description

The device is a manually operated seat valve, consisting of a manual actuator and a 2/2 way valve body.

The manual actuator is available in the following sizes:

Nominal diameter DN	Hand-wheel size	Designation	Handwheel diameter [mm]	Slope per rotation [mm]
15 to 25	S	Small	45	1.25
32 to 40	S/M	Small/ Medium	45/110	1.25 / 1.75
50	M	Medium	110	1.75
65 to 100	L	Large	160	2.0

Tab. 1: Handwheel sizes

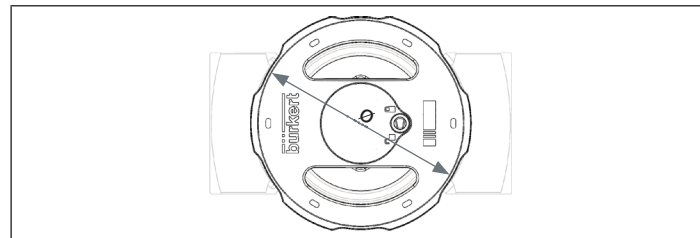

Fig. 1: Handwheel diameter

5.2 Variants

Types 2920, 2921, 2960 and 2961 differ due to the valve body and the control cone.

Type	Nominal diameter DN	Valve body	Properties
2920	10 to 80	Angle seat body	<ul style="list-style-type: none"> • without control cones • for pure shut-off function
2960	10 to 65		<ul style="list-style-type: none"> • with control cone • with position indicator and scale to set a defined flow rate
2921	10 to 100	Globe body	<ul style="list-style-type: none"> • without control cones • for pure shut-off function
2961	10 to 100		<ul style="list-style-type: none"> • with control cone • with position indicator and scale to set a defined flow rate • with screwed-in valve seat that can be replaced to reduce the seat size

Tab. 2: Variants

5.2.1 Type 2920, 2960

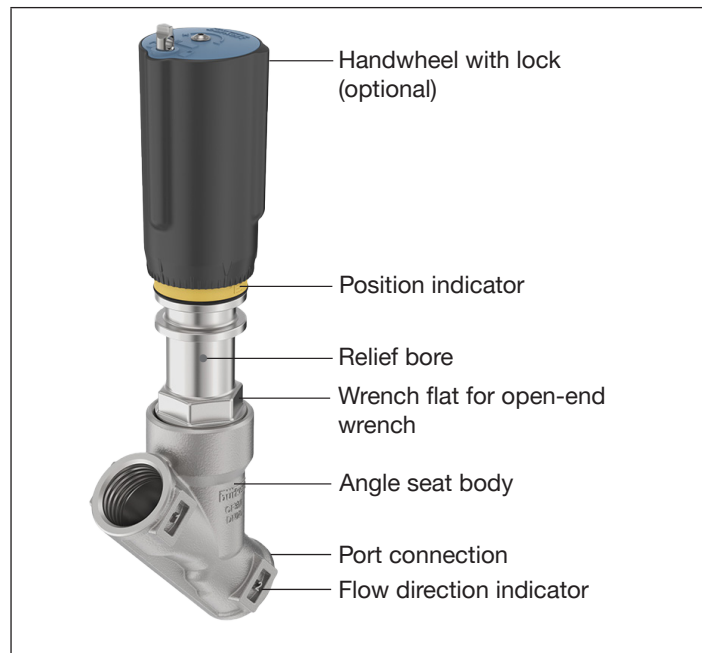

Fig. 2: Example of 2/2-way angle seat valve, type 2920

5.2.2 Type 2921, 2961

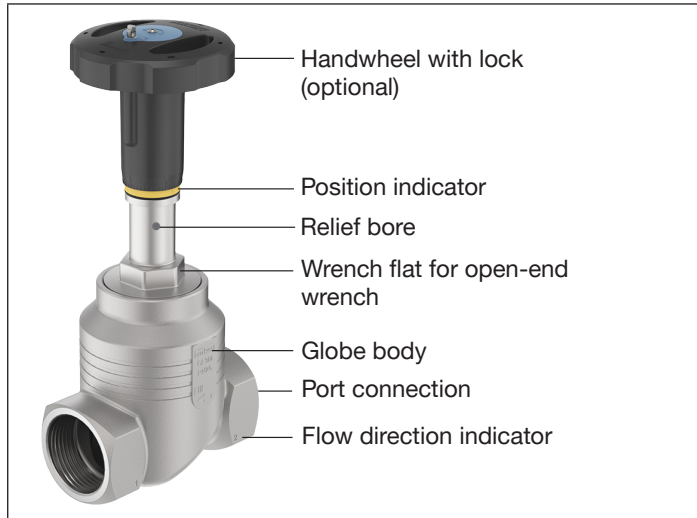

Fig. 3: Example of 2/2-way globe valve, type 2921

5.3 Function

By manually activating the handwheel, the force is transmitted via a spindle and the valve is opened or closed. The medium in the valve body is either approved or blocked off. Turning the handwheel anticlockwise opens the valve, turning it clockwise closes it.

To protect the actuator, we recommend not closing the actuator with more force than is required to shut off the medium pressure.

The following tightening torques must not be exceeded for the handwheel sizes: S: 7 Nm, M: 15 Nm, L: 30 Nm.

5.3.1 Position indicator

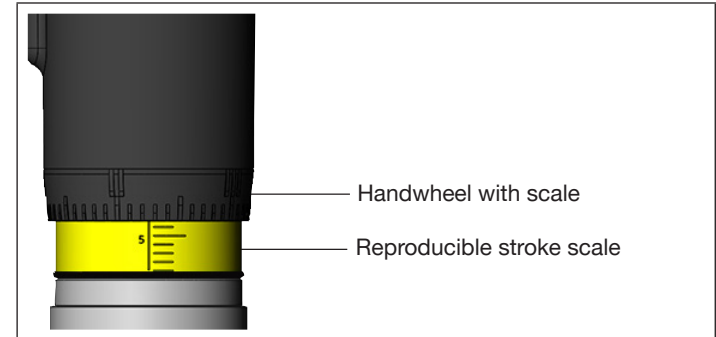

Fig. 4: Position indicator

When turning the handwheel anticlockwise, the reproducible stroke scale becomes visible between the position indicator and the handwheel.



The visibility of the stroke scale is not directly correlated with the closed position of the valve. Depending on the design of the valve, the reproducible stroke scale:

- may not be visible when the valve is open, or
- may be visible when the valve is closed.

The scale on the handwheel determines the rotation position of the handwheel (50 positions).

The reproducible stroke scale shows, depending on the bottom edge of the handwheel, the relative position of the valve (valve

opening) and acts as a fixation point for determining the rotation position.

In the case of valves with locking, the set position can be secured with a lock (see chapter “Lock handwheel”).



To set a defined flow rate, use the flow characteristic or the Kv table of values. This can be found in the data sheet at country.burkert.com

5.3.2 Flow direction

The valve seat is always closed against the medium flow. The flow direction should therefore be set such that the valve reaches the flow beneath the valve seat.

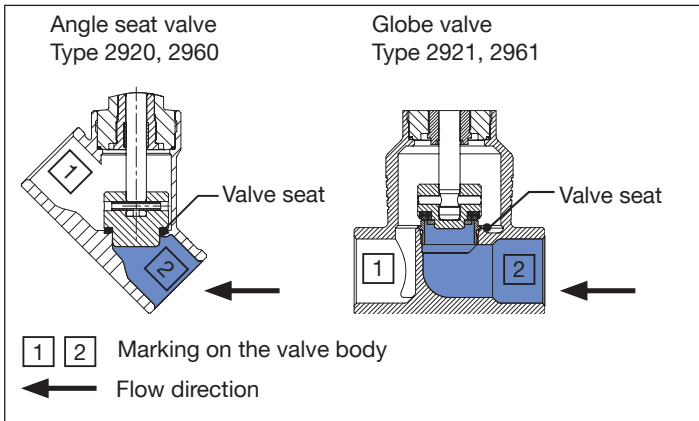

Fig. 5: Flow direction, flow direction below seat

5.3.3 Flow characteristic



Detailed values are listed in the data sheet on the home page: country.burkert.com

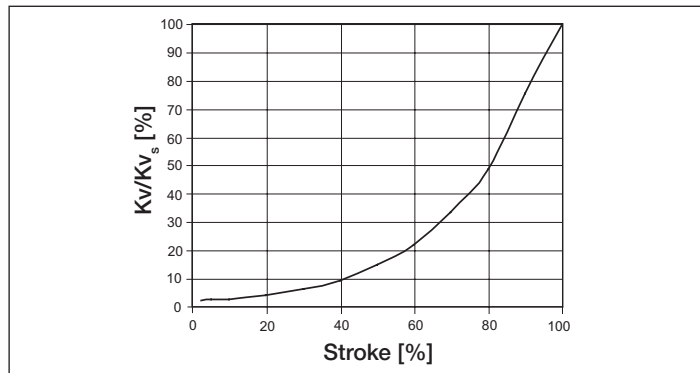

Fig. 6: Graphical presentation of the flow characteristic

- Cone of equal per cent for valve seat sizes 8 to 100
- Flow characteristic as per DIN EN 60534-2-4
- Theoretical rangeability (K_{VS}/K_{V0})
50: 1 for valve seat size 8 to 100
- K_{VR} value at 5% of the stroke for valve seat rate > 10
 K_{VR} value at 5% of the stroke for valve seat rate ≤ 10
(K_{VR} value = lowest K_V value at which the tilt tolerance can still be observed in accordance with DIN EN 60534-2-4)

5.4 Product identification

5.4.1 Type label

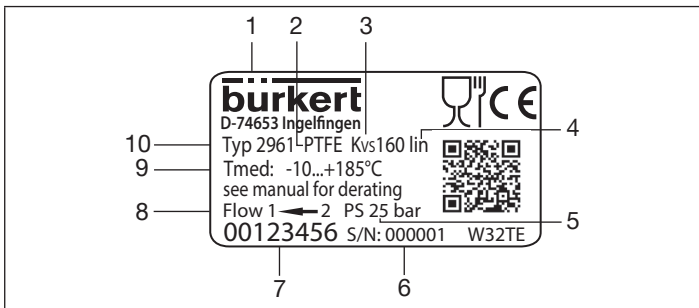

Fig. 7: Description of the type label (example)

Item	Description	Item	Description
1	Manufacturer	6	Serial number
2	Seal material	7	Article number
3	Flow coefficient in serial conditions	8	Flow direction
4	Control characteristic form (linear)	9	Medium temperature
5	Medium pressure	10	Type

6 TECHNICAL DATA

6.1 Standards and directives

The device complies with the valid EU harmonisation legislation. In addition, the device also complies with the requirements of the laws of the United Kingdom.

The harmonised standards that have been applied for the conformity assessment procedure are listed in the current version of the EU Declaration of Conformity/ UK Declaration of Conformity.

Observe the following operating conditions according to the Pressure Equipment Directive:

Nominal diameter of valve body DN	Maximum pressure for compressible fluids of Group 1
DN32-50	20 bar
DN65	15 bar
DN80	12.5 bar
DN100	10 bar

6.2 Operating conditions

Media	Neutral gases, water, alcohols, oils, fuels, saline solutions, lyes, organic solvents, vapour
Materials and ports	see data sheet

6.2.1 Temperatures

Ambient temperature	-10...+60 °C
Medium temperature	-10...+230 °C
Temperature for valve seat seal	for a medium temperature of up to 130 °C: PTFE* for a medium temperature of over 130 °C: PEEK*/steel**
	* Leakage class VI
	** Seal material is steel on request for leakage class II and III

6.2.2 Pressure

Nominal diameter DN	Maximum permissible pressure PS
DN15 to DN50	25 bar (or see type label)
DN65	24 bar (or see type label)
DN80	16 bar (or see type label)
DN100	10 bar (or see type label)

Tab. 3: Maximum permissible pressure

6.2.2.1 Pressure and temperature restriction (derating) of the valve body

Temperature [°C]	Operating pressure [bar]
-10...+50	25
100	24.5
150	22.4

Temperature [°C]	Operating pressure [bar]
200	20.3
230	19

Tab. 4: Derating the operating pressure as per DIN EN 12516-1/PN25

Temperature [°C]	Operating pressure [bar]
-29...+38	19
50	18.4
100	16.2
150	14.8
200	13.7
230	12.7

Tab. 5: Derating the operating pressure as per ASME B16.5/ ASME B16.34 Cl.150

Temperature [°C]	Operating pressure [bar]
-10...+50	14
100	14
150	13.4
200	12.4
230	11.7

Tab. 6: Derating the operating pressure as per JIS B 2220 10K

7 INSTALLATION



DANGER

Risk of injury due to high pressure and escaping medium.

- ▶ Switch off the pressure before working on the device or system. Vent or empty the lines.



WARNING

Risk of injury due to improper installation.

- ▶ Assembly may be carried out by authorised technicians only and with the appropriate tools.
- ▶ Observe tightening torques.

Risk of crushing by mechanically powered parts.

- ▶ Do not reach into the openings of the valve body.

Risk of injury due to unintentional activation of the system and uncontrolled restart.

- ▶ Secure the system against unintentional activation.
- ▶ Following installation, ensure a controlled restart.



CAUTION

Risk of injury due to heavy device.

During transportation or installation work, a heavy device may fall down and cause injuries.

- ▶ Transport, install and remove heavy device with the aid of a second person only.
- ▶ Use suitable tools.

7.1 Notes for correct installation

- Note the installation position. The device can be installed in any manner, preferably with the actuator facing upwards.
- Ensure pipes are aligned before connection.
- Note the flow direction. The flow direction is visible on the valve body and on the type label.
- Clear impurities from pipelines (seal material, metal chips, etc.).

7.1.1 Devices with welded connection

Remove the actuator from the valve body as follows:

- Turn the valve approx. twice to open it and to release the valve seat seal.
- Place a suitable open-end wrench on the wrench flat of the body connection.
- Unscrew actuator from the valve body.

7.1.2 Devices with threaded connection

- Only uninstall the actuator if required by the customer.

7.2 Installing valve body

Valve body with welded connection

- Weld or bond valve body in pipe system.

Other body variants:

- Connect valve body to pipe.

7.3 Install the actuator on devices with a welded connection

→ Check and replace seal. Make certain that no remnants of seal material get into the pipe system.

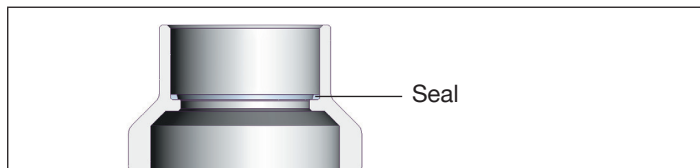

Fig. 8: Seal

! WARNING

Danger due to incorrect lubricants.

Unsuitable lubricant may contaminate the medium. There is a risk of explosion in oxygen applications.

▶ Only used accordingly approved lubricants for specific applications.

- Grease the external thread of the body connection (e.g. with Klüberpaste UH1 96-402 from Klüber).
- Screw actuator into valve body, noting the tightening torque in accordance with "Tab. 7".

Nominal diameter of valve body DN	Tightening torque [Nm]	Tolerance
10/15	45	±3
20	50	±3

Nominal diameter of valve body DN	Tightening torque [Nm]	Tolerance
25	60	±3
32	65	±3
40	65	±3
50	70	±3
65	100	±3
80	120	±5
100	150	±5

Tab. 7: Tightening torque values for screwing into the valve body

7.4 Set stroke limit

Setting the minimum and maximum stroke limit is possible as an option. An adjusting sleeve is used for this purpose.

- By turning the handwheel clockwise, the valve is moved to the closed position.
- Loosen the screw on the handwheel (hexagon socket, width across flats 2) and remove handwheel.
- Screw adjusting sleeve clockwise until it comes to a stop. Minimum stroke is set.
- Mount handwheel on actuator. The square on the spindle and the hexagon head of the adjusting sleeve must be correctly aligned to the geometry of the handwheel so that they fit into each other.
- Move the valve to the desired maximally open position.

- Loosen the screw on the handwheel and remove the handwheel.
- Pull adjusting sleeve upwards and at the same time, screw anticlockwise until it comes to a stop. Maximum stroke is set.

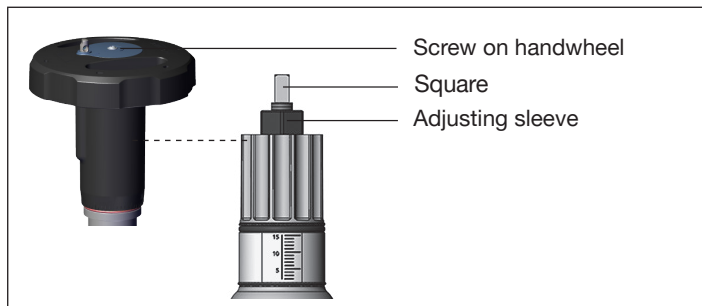

Fig. 9: Set stroke limit

- Mount handwheel on actuator. The square on the spindle and the hexagon head of the adjusting sleeve must be correctly aligned to the geometry of the handwheel so that they fit into each other.
- Tighten the screw on the handwheel with a tightening torque of 0.9 Nm.
If necessary, bond the screw to ensure a permanent hold.

7.5 Lock handwheel

It is also an option to lock the handwheel to prevent unintentional or unauthorised operation of the valve.

- Handwheel size S can be locked in 12 locking positions per revolution (every 30° corresponds to 0.1 mm of stroke)
- Handwheel sizes M and L can be locked in 13 locking positions per revolution (every 27° corresponds to 0.13 mm of stroke with handwheel size M and 0.15 mm of stroke with size L)

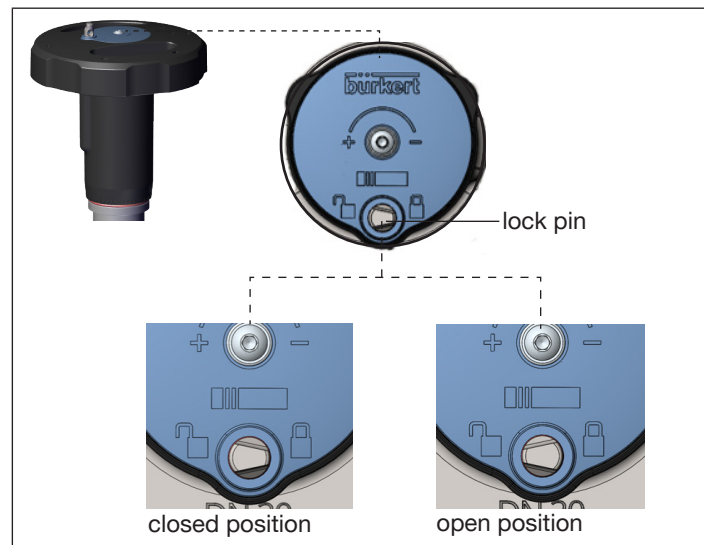



Fig. 10: Lock handwheel

 The lock pin has a bore (Ø 3.8) and can be secured against unauthorised use with a padlock (not included in scope of delivery).

 Depending on the operating and usage conditions, the specified leakage class cannot be guaranteed if the closed position is locked.

- Push lock pin down and rotate by 180° (either clockwise or anti-clockwise). It may be necessary to turn the handwheel slightly so that the lock pin reaches its end position. The lock pin must lock into its end position so that the drill hole is fully visible once again.
- Insert padlock through the bore in the lock pin and secure.

8 DISASSEMBLY

 **DANGER**

Risk of injury due to high pressure and escaping medium.

- ▶ Switch off the pressure before working on the device or system. Vent or empty the lines.

- Switch off pressure and drain lines. Rinse the pipeline if toxic media have been used.
- Disassemble the device.

9 MAINTENANCE

 **DANGER**

Risk of injury due to high pressure and escaping medium.

- ▶ Switch off the pressure before working on the device or system. Vent or empty the lines.

Discharge of medium if packing gland worn.

- ▶ Inspect relief bore for any medium leakages.
- ▶ If the medium is hazardous, secure the environment against risks.

 **WARNING**

Risk of injury due to improper maintenance.

- ▶ Maintenance may only be performed by authorised technicians and with the appropriate tools.

9.1 Maintenance work

9.1.1 Actuator

When used in accordance with these operating instructions, the actuator of the manually operated valve is maintenance-free.

9.1.2 Inspection intervals

- Perform a visual inspection of the device once per year.
- If leaks occur, replace the respective wearing part.

 Muddy and abrasive media require correspondingly shorter inspection intervals.

9.2 Cleaning

Use commercially available cleaning agents for external cleaning.

NOTE

Avoid causing damage with cleaning agents.

- ▶ Before cleaning, check that the cleaning agents are compatible with body materials and seals.

9.3 Faults

Fault	Cause	Elimination
Valve is not tight	Dirt between seal and valve seat	Install dirt trap
	Valve seat seal worn	Install new control cone
	Flow direction interchanged	Observe the marking for the flow direction on the valve body
	Operating pressure too high	Observe pressure specifications on the type label
Valve is leaking on the relief bore	Packing gland worn	Replacing packing gland

Tab. 8: Faults

10 SPARE PARTS



CAUTION

Risk of injury and/or damage due to incorrect parts.

Incorrect accessories and unsuitable spare parts may cause injuries and damage the device and the area around it.

- ▶ Use only original accessories and original spare parts from Bürkert.

Spare parts can be ordered depending on the variant and valve assembly:

- Order by entering the article number in [eShop](#) (see chapter "10.1")
- Order by entering the spare part set



Exact details for finding spare and wear parts are in the [catalogue of spare and wear parts](#).

10.1 Order spare parts in eShop

→ Open Bürkert [eShop](#) on the internet.

→ Log in or register.

→ Find spare parts via the article number. This can be seen on the type label on the device.

Spare parts, quick ordering and related documents

Quickorder	Spare parts	Document Search						
<p>Already know what you want?</p> <table border="1"> <tr> <td>Article Number</td> <td>Qty.</td> </tr> <tr> <td>Article Number</td> <td>Qty.</td> </tr> <tr> <td>Article Number</td> <td>Qty.</td> </tr> </table> <p>Add to cart</p>	Article Number	Qty.	Article Number	Qty.	Article Number	Qty.	<p>Find related spare & wear parts:</p> <p>Enter article number <input type="text"/> <input type="button" value="🔍"/></p>	<p>Find related documents:</p> <p>Type number <input type="text"/> <input type="button" value="🔍"/></p>
Article Number	Qty.							
Article Number	Qty.							
Article Number	Qty.							

→ Put spare parts in the basket and complete order.

 If you cannot find spare parts, contact your Bürkert service employee.

11 TRANSPORTATION, STORAGE, DISPOSAL



CAUTION

Risk of injury due to heavy device.

During transportation or installation work, a heavy device may fall down and cause injuries.

- ▶ Heavy equipment must only be transported, assembled and disassembled with the help of a second person.
- ▶ Use suitable tools.

NOTE

Damage in transit due to inadequately protected devices.

- ▶ Protect the device against moisture and dirt in shock-resistant packaging during transportation.
- ▶ Observe permitted storage temperature.

Incorrect storage may damage the device.

- ▶ Store the device in a dry and dust-free location.
- ▶ Storage temperature $-20\text{ °C} \dots +65\text{ °C}$.

Environmentally friendly disposal



- ▶ Follow national regulations regarding disposal and the environment.
- ▶ Collect electrical and electronic devices separately and dispose of them as special waste.

Further information at country.burkert.com

www.burkert.com