

Typ 2012, 2702, 2712

Spare parts
Ersatzteile
Pièces de rechange



Operating Instructions

Bedienungsanleitung
Instructions de Service

We reserve the right to make technical changes without notice.
Technische Änderungen vorbehalten.
Sous réserve de modification techniques.

© Bürkert Werke GmbH & Co. KG, 2004 - 2021

Operating Instructions 2112/24_EU-ML_00804495 / Original DE

SPARE PARTS FOR TYPES 2012, 2702, 2712

Contents

Symbols	3
Safety notes	4
Contact addresses	4
Warranty conditions	4
Overview of types	5
Spare parts sets for standard valves	6
Exchange of spare parts	10
Disassembly	10
Replacing the valve seat	11
Assembly tools	12
Replacing the control cone	13
Turning the actuator	14

Symbols

The following symbols are used in these operating instructions:

→ marks a work step that you must carry out



ATTENTION!

marks notes on whose non-observance your health or the functioning of the device will be endangered.



NOTES

marks important additional information, tips and recommendations

Safety notes



To ensure serviceability and a long service life, please comply with the information in these operating instructions, also the operating conditions and permissible data specified in the datasheets for the utilized components:

- Keep to standard engineering rules in planning the use of and operating the device!
- Installation and maintenance work are only allowed by specialist personnel using suitable tools!
- Observe the current regulations on accident prevention and safety for electrical devices during operation and maintenance of the device!
- Switch off the supply voltage in all cases before intervening in the system!
- Note that in systems under pressure, piping and valves may not be loosened!
- Take suitable precautions to prevent inadvertent operation or damage by unauthorized action!
- On non-observance to these notes and unauthorized interference with the device, we will refuse all liability and the warranty on device and accessories will become void!

Contact addresses

Germany

Bürkert Fluid Control Systems
Sales Center
Christian-Bürkert-Str. 13 - 17
D-74653 Ingelfingen
Tel.: +49 (0)7940/ 10 91 111
+49 (0)7940/ 10 91 448
E-mail: info@de.buerkert.com

International

Contact addresses can be found on the final pages of these printed operating instructions. And also on the internet at: www.burkert.com

Warranty conditions

A prerequisite for validity of the warranty is use of the devices as intended with observance of the specified conditions of use.



ATTENTION!

The guarantee only covers the serviceability of the delivered components. No liability is accepted for any kind of secondary damage which can occur through the failure or malfunction of the components.

Overview of types

- 1** Type 2012
Piston controlled flat-seat valve
Actuator sizes 40 - 125 mm,
Nominal diameters DN 10 - DN 100

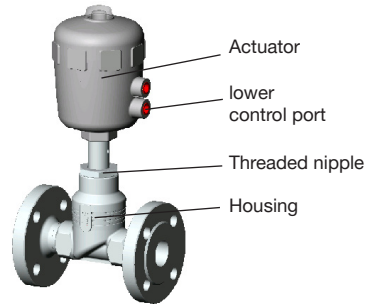

- 2** Type 2012
Piston controlled flat-seat valve
Actuator sizes 175 and 225 mm,
Nominal diameters
DN 65, DN 80, DN 100

- 5** Type 2712
Piston controlled flat-seat control valve
Actuator size 175 and 225 mm,
Nominal sizes DN65, DN80, DN100

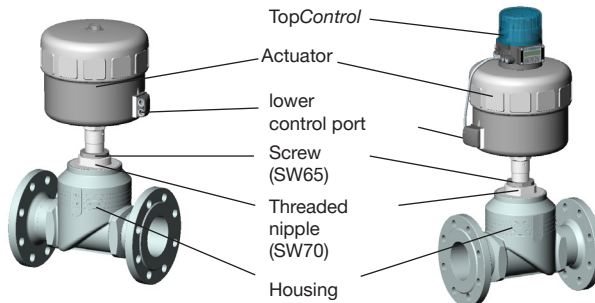

- 3** Type 2702
Piston controlled Y control valve
Actuator sizes 80 - 125 mm,
Nominal diameters DN 13 - DN 65

- 4** Type 2712
Piston controlled flat-seat control valve
Actuator sizes 80 - 125 mm,
Nominal diameters DN 10 - DN 65

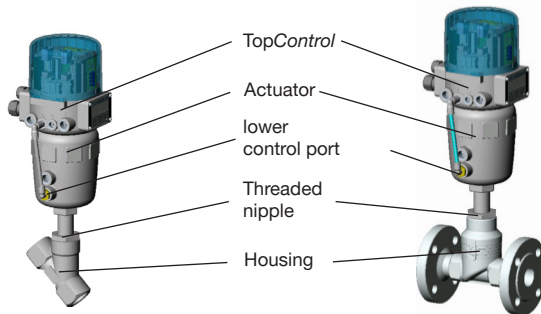

Spare parts sets for standard valves



NOTE

Spare parts sets for special versions are available on request (e. g. oxygen, analysis versions, etc.)

On installation of a valve seat with a different nominal diameter, the order number for the valve changes.



ATTENTION!

Before removal or opening of the device, be sure to interrupt the supply of medium and relieve the pressure in the piping.



ATTENTION!

Open piston actuator carefully – risk of accident from tensioned springs.



Set of seals for PPS actuator
High temperature version

Actuator size/Nom. diameter	Order no.
Ø 40 / DN10, 15, 20, 25	233 581
Ø 50 / DN10, 15, 20, 25	233 582
Ø 63 / DN25 – 50	233 583
Ø 80 / DN25 – 65	233 584
Ø 100 / DN32 – 65	233 585
Ø 125 / DN40 – 65	233 586
Ø 125 / DN80 – 100	276 130



Set of seals for PA actuator
Standard version

Actuator size/Nom. diameter	Order no.
Ø 40 / DN10, 15, 20, 25	233 587
Ø 50 / DN10, 15, 20, 25	233 588
Ø 63 / DN25 – 50	233 591
Ø 80 / DN25 – 65	233 593
Ø 100 / DN32 – 65	233 594
Ø 125 / DN40 – 65	233 596
Ø 125 / DN80 – 100	276 132
Ø 175 / DN65 – 100	168 501
Ø 225 / DN65 – 100	168 500



Conversion set

Actuator	SFA to SFB or SFI	Flow direction below seat to flow direction above seat	Flow direction above seat to flow direction below seat
Ø 50	012 090	011 985	012 016
Ø 63	011 946	012 124	012 023
Ø 80	011 955	012 005	012 029
Ø 100	011 957	Remove outer spring	012 071
Ø 100 (R)	276 318	Remove outer spring	012 071
Ø 125	011 964	Remove outer spring	012 086
Ø 125 (R)	276 319	Remove outer spring	012 086

**1 Swivel plate set (PTFE seal material)
Trim kit (Swivel plate set + seat)**

DN	Order no. for swivel plate set	Order no. for valve set plus seat
10/15	149 606	149 608
20	011 171	149 864
25*	011 202	161 376
25**	160 737	149 786
32	011 208	149 787
40	011 209	149 788
50	233 813	237 390
65	233 815	237 391

Swivel plate set containing: pendulum disk, pin, graphite seal

Trim kit containing: pendulum disk, pin, graphite seal and seat

For assembly tools, see under "Replacing the valve seat"

* Actuator size Ø 50

** Actuator size Ø 63,80

**2 Trim kit (Swivel plate set + seat)
(PTFE seal material)**

Actuator size	Nominal diameter	Order no.
175	DN 65	155 487
175, 225	DN 80	155 488
175, 225	DN 100	155 489

Containing: pendulum disk, pin, graphite seal, seat

For assembly tools, see under "Replacing the valve seat"

**2 Swivel plate set
(PTFE seal material)**

Actuator size	Nominal diameter	Order no.
175	DN 65	155 491
175, 225	DN 80	155 492
175, 225	DN 100	155 493

Containing: pendulum disk, pin, graphite seal

2 Set of seals, packed gland

Actuator size	Nominal diameter	Order no.
175	DN 65	353 575
175, 225	DN 80	353 575
175, 225	DN 100	353 575

Containing: packed gland module, graphite seals

3 Plug set

DN	Steel/ Steel	PTFE/ Steel
	Order no.	Order no.
15	170 322	170 315
20	170 323	170 316
25	170 324	170 318
32	170 325	170 319
40	170 326	170 320
50	170 327	170 321
65	171 093	171 092

Containing: plug, dowel pin, graphite seal, lubricant

4 Plug set

DN	DN	Steel/ Steel	PTFE/ Steel
Housing	Seat	Order no.	Order no.
10, 15	4	149 934	
10, 15	6	152 696	
10, 15	8	149 935	149 962
10, 15	10	149 912	149 963
20	10	149 914	149 965
15	15	149 915	149 943
20	15	149 916	149 944
25	15	149 917	149 945
20	20	149 918	149 946
25	20	149 951	149 947
32	20	149 952	149 948
25	25	149 953	149 949
32	25	149 954	149 950
40	25	149 955	150 001
32	32	149 956	150 002
40	32	149 957	150 003
50	32	149 958	150 004
40	40	149 959	150 006
50	40	149 960	150 007
50	50	149 961	150 008
65	40	155 624	155 636
65	50	155 626	155 638
65	65	155 629	155 641

Contains: Plug, dowel pin, graphite seal, lubricant

4 Valve seat set

DN Housing	DN	Order no.
10, 15	4	262 143
10, 15	6	262 146
10, 15	8	262 147
10, 15	10	262 149
20	10	262 151
15	15	262 152
20	15	262 153
25	15	262 155
20	20	262 157
25	20	262 160
32	20	262 163
25	25	262 170
32	25	262 171
40	25	262 173
32	32	262 174
40	32	262 175
50	32	262 176
40	40	262 177
50	40	262 178
50	50	262 179
65	40	262 202
65	50	262 203
65	65	262 204

Contains: Valve seat, O-Ring (depending on version), graphite seal, lubricant

5 Sealing part set (packed gland)

DN housing	Order no.
65	353 575
80	353 575
100	353 575

Contains:
packed gland module,
housing seals

5 Plug set

DN housing	DN seat	Actuator size	Steel/Steel	PTFE/Steel
			Order no.	Order no.
65	40	Ø175	155 625	155 637
65	50	Ø175	155 627	155 639
65	65	Ø175	155 630	155 642
80	50	Ø225	155 628	155 640
80	65	Ø225	155 631	155 643
80	80	Ø225	155 633	155 645
100	65	Ø225	155 632	155 644
100	80	Ø225	155 634	155 646
100	100	Ø225	155 635	155 647

Contains:
Plug, dowel pin,
graphite seal

5 Valve seat set

DN housing	DN seat	Order no.
65	40	262 202
65	50	262 203
65	65	262 204
80	50	262 205
80	65	262 206
80	80	262 207
100	65	262 208
100	80	262 209
100	100	262 210

Contains:
Valve set,
O-Ring,
Graphite seal

Exchanging spare parts

Disassembly

Type	2012				2702		2712			
	①		②		③		④		⑤	
Actuator mm	40 - 125		175, 225		80 - 125		80 - 125		175, 225	
DN mm	10 - 100		65 - 100		15 - 65		10 - 65		65 - 100	
Control function	A	B, I	A	B, I	A	B	A	B	A	B
Remove the electrical and pneumatic supplies from the <i>TopControl</i>					X	X	X	X	X	X
Remove pneumatic supply and electrical connection if pilot valve is attached	X	X	X	X						
Pull off the pneumatic hose between <i>TopControl</i> and actuator at control port of actuator					X	X	X	X	X	X
Pressurize the lower control port of the actuator with compressed air ¹⁾	6 bar		6 bar		6 bar		6 bar		6 bar	
Do not apply compressed air		X		X		X		X		X
Remove the actuator in the open valve position by unscrewing the threaded nipple from the housing	X	X	X ²⁾	X ²⁾	X	X	X	X	X ²⁾	X ²⁾
Attention! Do not loosen screw (SW65) above threaded nipple!			X	X					X	X

1) The control cone lifts from the valve seat and is not damaged.

2) Threaded nipple SW70

Replacing the valve seat

Type	2012		2712	
	①	②	④	⑤
Actuator mm	40 - 125	175, 225	80 - 125	175, 225
DN mm	10 - 100	65 - 100	10 - 65	65 - 100
Unscrew the old seat using the assembly tool and a spanner	X			
Clean thread and sealing surface in the housing with compressed air	X			
Select a tool insert and screw it into the assembly tool	X			
Push the new seat onto the assembly tool	X			
Lubricate with high temperature resistant lubricant, e.g. Klüberpaste UH1 96-402 ³⁾	X			
Place the attached seat by hand into the housing thread and screw it in	X			
Tighten the seat with a torque wrench to the torque specified ⁴⁾	X			
Assemble in the reverse order to that described for disassembly	X			

english

³⁾  **ATTENTION!**

For special applications such as for oxygen and analysis, use only the approved lubricants.

⁴⁾ Torques:

Connection		Torque		Tolerance
Seat DN	Housing DN	Uncoated seat	Coated seat	
4 -15	15	25	20	+ 3
20	20	35	28	+ 3
25	25	50	40	+ 5
32	32	80	65	+ 5
40	40	100	85	+ 8

Connection		Torque		Tolerance
Seat DN	Housing DN	Uncoated seat	Coated seat	
50	50	120	120	+ 8
65	65	150	150	+ 10
80	80	180	180	+ 10
100	100	220	220	+ 10



NOTE

On installation of a valve seat with a different nominal diameter, the order number for the valve changes.

Assembly tools

1 Assembly tools for valve set plus seat

DN	Order no.
10/15	652 604
20	652 605
25	652 606
32	652 607
40	652 608
50	652 609
65	655 562
80	655 563
100	655 564

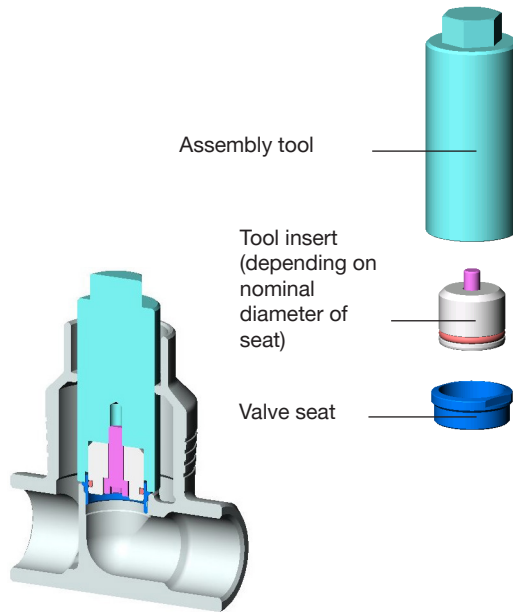

2 Assembly tools for valve set plus seat

Actuator size	DN	Order no.
175	65	653 562
175, 225	80	653 563
175, 225	100	653 564

4 Assembly tools

DN	Order no.
15	652 604
20	652 605
25	652 606
32	652 607
40	652 608
50	652 609

5 Assembly tools

DN	Order no.
65	655 562
80	655 563
100	655 564

Replacing the control cone

Type	2702	2712	
	③	④	⑤
Actuator mm	all	80 - 125	175, 225
DN mm		10 - 65	65 - 100
Knock out the dowel pin with a suitable driver ⁵⁾	X	X	X
Clamp two equally long metal bars to the left and right of the spindle between control cone and threaded nipple of actuator	X	X	X
Apply compressed air to the lower control port of actuator	6 bar	6 bar	6 bar
Pull off control cone with the aid of the metal bars	X	X	X
Push the new control cone over the end of the spindle Attention! Do not damage the sealing surface or the control contour!	X	X	X
Align the bores	X	X	X
Support the control cone at its cylindrical part with the aid of a V-block or the like	X	X	X
Position dowel pin	X	X	X
Carefully knock the dowel pin into the bore with a hammer	X	X	X
Bring the dowel pin into a central position relative to the spindle axis	X	X	X
Knock in the dowel pin up to the of the recess	X	X	X
Tighten threaded nipple Observe torque! ⁶⁾	X	X	X
Grease the thread with high temperature resistant lubricant, e. g. Klüberpaste UH1 96-402 Attention! Valve must be open	X ⁷⁾	X ⁷⁾	X ⁷⁾
Replace graphite seal if necessary			X
Assemble the actuator in the reserve order to that described for disassembly	X	X	X

5) Diameter of driver

③ ④	up to DN 25	4 mm
	DN 32 - DN 65	5 mm
⑤	DN 65 - DN 100	8 mm

6) For tightening torques for threaded nipple (SW 70), see the following page

7)  **ATTENTION!**

For special applications such as for oxygen and analysis, use only the approved lubricants.

⑤ Tightening torques for threaded nipple (SW 70)

DN	Tightening torque [Nm]
65	100 ^{±5}
80	120 ^{±5}
100	150 ^{±5}

③ ④ Control cone

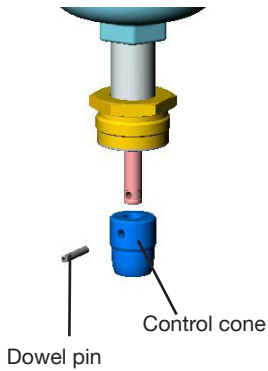

⑤ Control cone

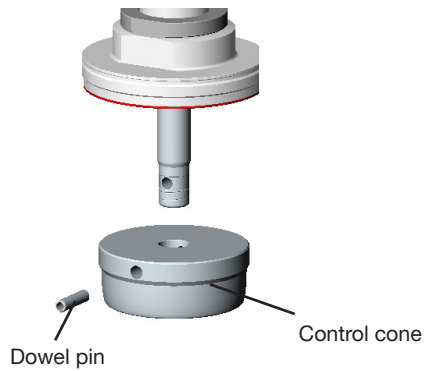

Turning the actuator

Type	2702	2712	
	③	④	⑤
Actuator mm	all	80 - 125	175, 225
DN mm		10 - 65	65 - 100
Unscrew the screw (SW65) above threaded nipple by ca. half a turn			X
Bring actuator into the desired position Attention! Valve must be open	X	X	X
Tighten screw with 100 ± 5 Nm			X

MAN 1000010233 ML Version: AH Status: RL (released | freigegeben) printed: 22.11.2024