

type 2000, 2006, 2012

Change of valve and seal sets
Conversion of control functions

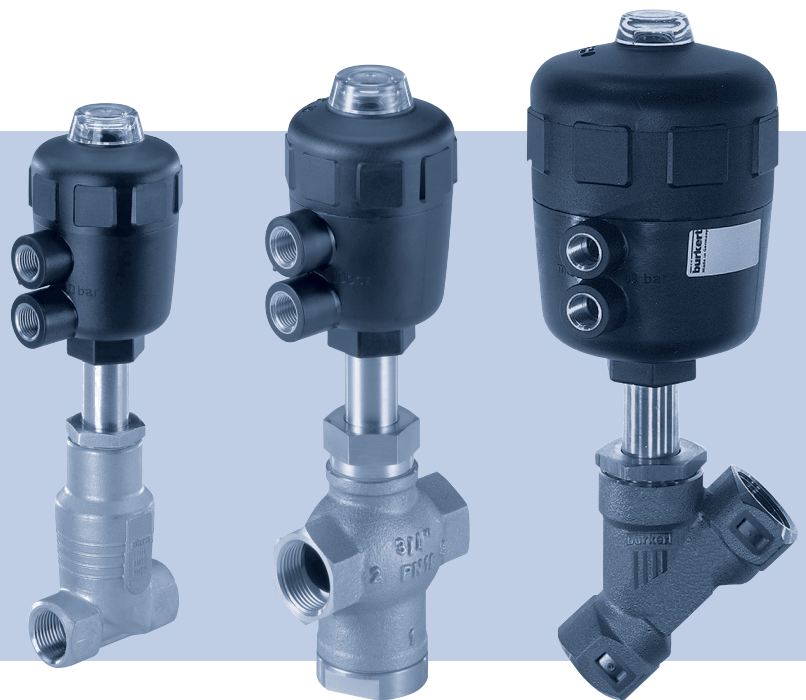

Service instructions

We reserve the right to make technical changes without notice.
Technische Änderungen vorbehalten.
Sous réserve de modifications techniques.

© Bürkert Werke GmbH & Co. KG, 2015 - 2021

Operating Instructions 2111/17_DE-EN_00804144 / Original DE

Table of contents

1	SERVICE INSTRUCTIONS.....	5
1.1	Symbols.....	5
2	BASIC SAFETY INSTRUCTIONS	6
3	GENERAL NOTES.....	7
3.1	Contact addresses.....	7
3.2	Warranty	7
3.3	Information on the Internet	7
3.4	Reengineering	7
3.5	Auxiliary materials.....	7
4	CLOSE-UP DRAWINGS.....	8
5	REPLACING THE SEAL SET	10
5.1	Disassembly	10
5.2	Installation	12
6	CHANGING THE PACKING GLAND.....	15
7	CHANGING THE PENDULUM DISC SET PROCESS VALVE.....	18
8	CHANGING THE VALVE SET (TYPE 2012).....	20
9	CONVERTING CONTROL FUNCTION	22
9.1	Description of control functions.....	22
9.1.1	Control function A (CFA)	22
9.1.2	Control function B (CFB).....	22
9.1.3	Control function I (CFI).....	22
9.1.4	Flow direction below seat.....	22
9.1.5	Flow above seat.....	23
9.2	Conversion from control function A (CFA) to B (CFB)	24
9.3	Conversion from control function A (CFA) to I (CFI)	26
9.4	Conversion from flow direction above the seat to flow direction below seat.....	27
9.5	Conversion from flow direction below seat to flow direction above the seat.....	28

10	INSTALLATION TOOLS.....	29
10.1	Assembly wrench for actuator cover	29
10.2	Assembly tools for packing gland.....	30
10.2.1	Assembly sleeve	30
10.2.2	Installation wrench.....	30
10.3	Assembly tool for valve seat	31
11	PARTS ORDER	32
11.1	Replacement part sets.....	32
11.1.1	Actuator seal set.....	36
11.1.2	Swivel plate set process valve.....	37
11.1.3	Valve trim (Type 2012).....	38
11.1.4	Seal set swivel plate (Type 2012).....	38
11.1.5	Seal set packing gland (Type 2012).....	38
11.2	Conversion sets type 2000 and 2012.....	39
11.2.1	Conversion set for switching from CFA to CFB or CFI.....	39
11.2.2	Conversion set for switching from flow direction above the seat to flow direction below seat	39
11.2.3	Conversion set for switching from flow direction below seat to flow direction above the seat	39

1 SERVICE INSTRUCTIONS

The service instructions describe the procedure for:

- replacing valve and seal sets for process valves of types 2000, 2006 and 2012.
- converting the control function of process valves of type 2000 (angle seat valve) and types 2006 and 2012 (globe valves).

Keep these instructions in a place that is easily accessible to all users and ensure they are available to all new owners of the device.



WARNING!

The service instructions contain important safety information.

Failure to observe these instructions may result in hazardous situations.

- ▶ The service instructions must be read and understood.

1.1 Symbols



DANGER!

Warns of an immediate danger!

- ▶ Failure to observe these instructions will result in death or serious injuries.



WARNING!

Warns of a potentially hazardous situation!

- ▶ Failure to observe these instructions may result in serious injuries or death.



CAUTION!

Warns of a potential danger!

- ▶ Failure to observe these instructions may result in moderate or minor injuries.

NOTE!

Warns of damage to property!

- ▶ Failure to observe the warning may result in damage to the device or the equipment.



Indicates important additional information, tips and recommendations.



Refers to information in these operating instructions or in other documentation.

- ▶ Designates instructions to avoid a danger.

→ Highlights a procedure which you must carry out.

2 BASIC SAFETY INSTRUCTIONS

These safety instructions do not take account of any

- contingencies or events which may occur during installation, operation and maintenance of the devices;
- local safety regulations that are within the operator's scope of responsibility, including those relating to the installation personnel.



High pressure danger!

- ▶ Before loosening lines or valves, switch off the pressure and bleed the lines.

Danger from electrical voltage.

- ▶ Before reaching into the device or the system, switch off the power supply and secure it against reactivation.
- ▶ Observe the applicable accident prevention and safety regulations for electrical devices!

Risk of burns/fire due to hot device surface if device operated continuously.

- ▶ Keep the device away from highly flammable substances and media and do not touch with bare hands.

General hazardous situations.

- ▶ Ensure that the system cannot be activated unintentionally.
- ▶ Make sure only trained technicians carry out installation and maintenance work.
- ▶ After an interruption in the power or pneumatic supply, ensure that the process is restarted in a defined or controlled manner.
- ▶ Operate the device only when it is in perfect condition and in accordance with the operating instructions.
- ▶ The general rules of technology apply to application planning and operation of the device.

3 GENERAL NOTES

3.1 Contact addresses

Germany

Bürkert Fluid Control Systems
 Sales Centre
 Christian-Bürkert-Str. 13-17
 D-74653 Ingelfingen
 Tel. +49 (0) 7940 - 10 91 111
 Fax +49 (0) 7940 - 10 91 448
 E-mail: info@burkert.com

International

The contact addresses can be found on the back pages of the printed operating instructions.

They are also available online at: www.burkert.com

3.2 Warranty

A precondition for the warranty is that types 2000, 2006 and 2012 are used as intended in consideration of the specified operating conditions.

3.3 Information on the Internet

Operating instructions and data sheets for types 2000, 2006 and 2012 can be found online at: www.burkert.com

3.4 Reengineering

Due to the reengineering of the types 2000 and 2012, the spare parts change. The spare parts sets contain the spare parts for both valve versions. The valves optimised by reengineering are marked with the letter "R" (see first line of the type label).

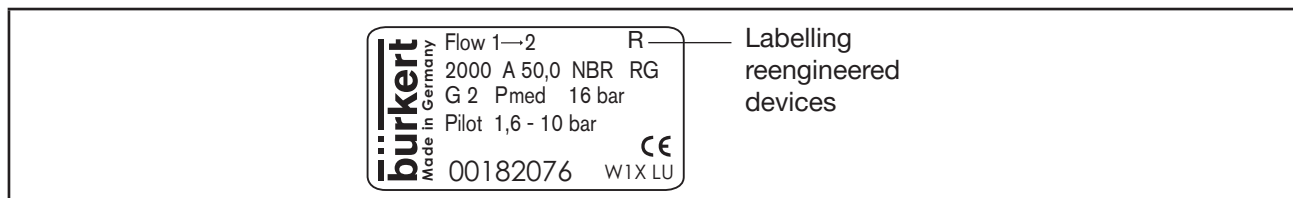

Image 1: Example of a type label marked "R" for "reengineering"

3.5 Auxiliary materials

The following auxiliary materials are recommended in these instructions for conversion and repair:

Type of auxiliary material	Auxiliary material	Manufacturer information
Seal and lubrication materials	Silicone grease OKS 1110-3	OKS Schmierstoffe GmbH www.oks-germany.com
Lubricant paste	Klüber paste UH1 96-402	Klüber Lubrication München www.klueber.de
lubricant	Silicone grease OKS 1110-1	OKS Schmierstoffe GmbH www.oks-germany.com
Screw lock	Loctite 274	Henkel Loctite Deutschland GmbH www.loctite.de

4 CLOSE-UP DRAWINGS

Control function A
(closed by spring force
in rest position)

Actuator sizes G (R), H (R)

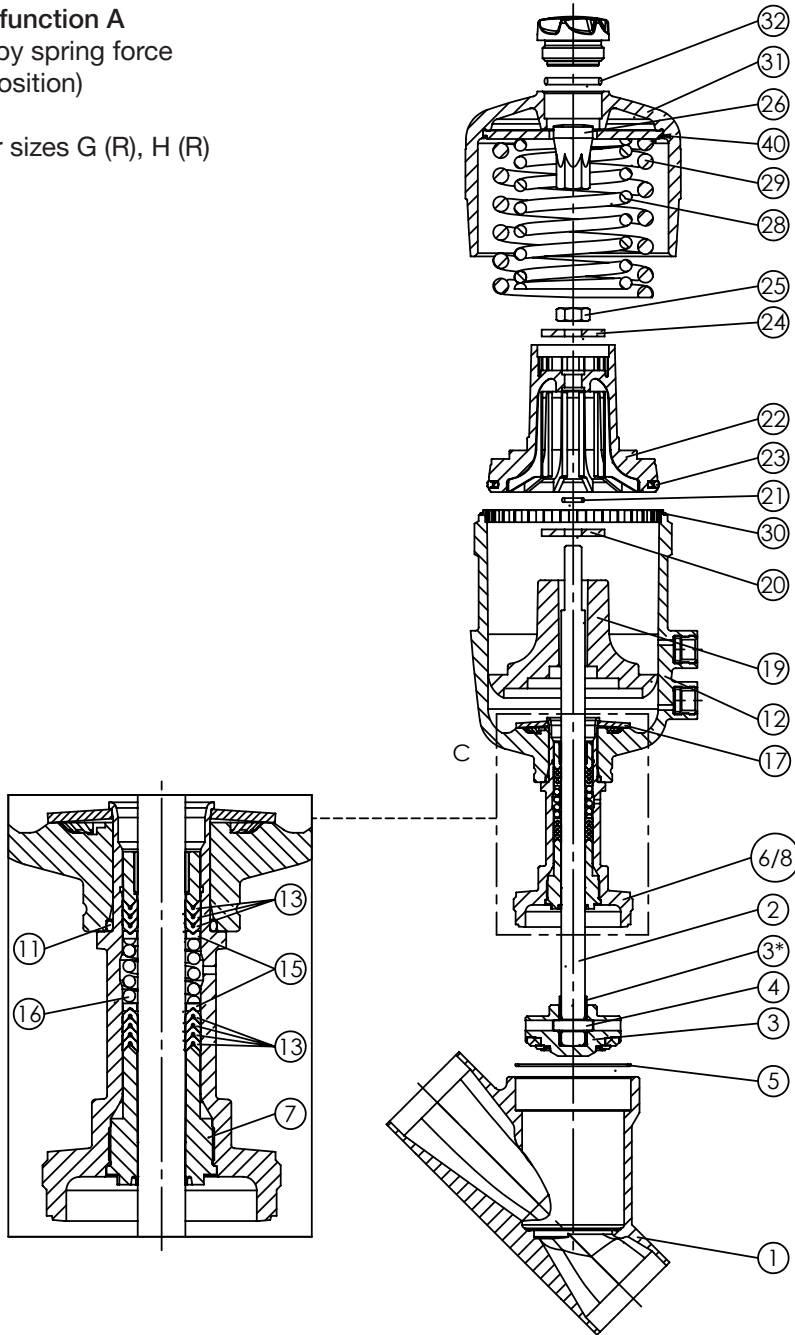

* Sleeve required
to reduce drill hole size
(starting at DN50)

Valve body

Type 2000

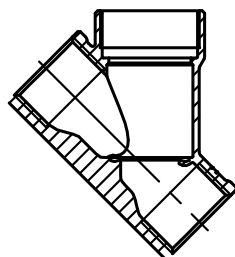

Type 2006

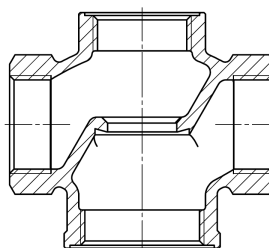

Type 2012

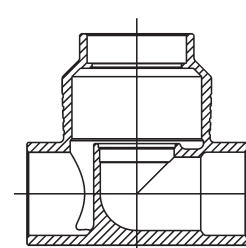

Control function B
(opened by spring force
in rest position)

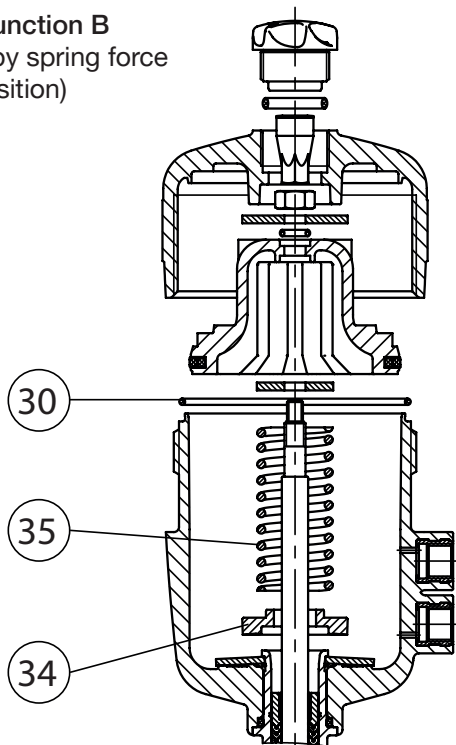

Control function I
(double active)

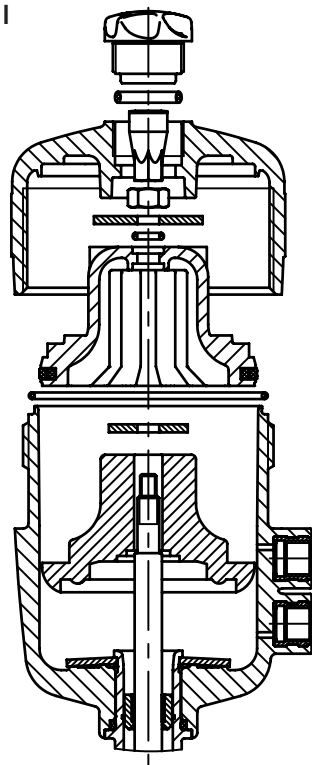

Actuator size C, control function A
(without transparent cap)

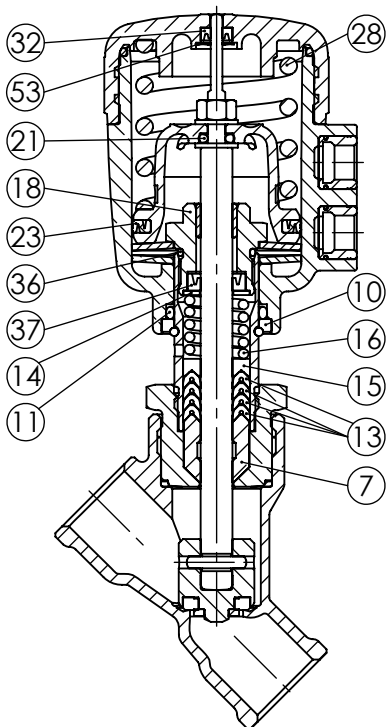

Actuator size C, control function B
(with transparent cap)

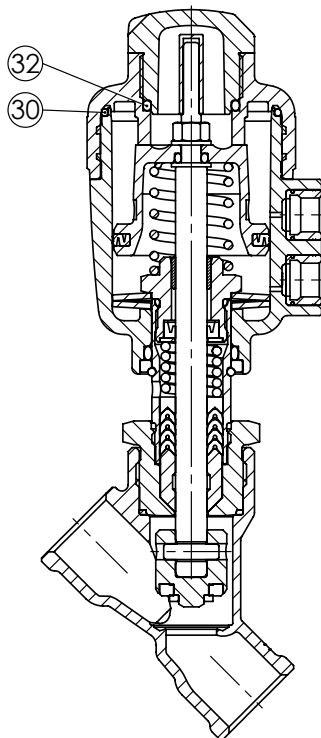

Actuator sizes C, D, E, F, G, H

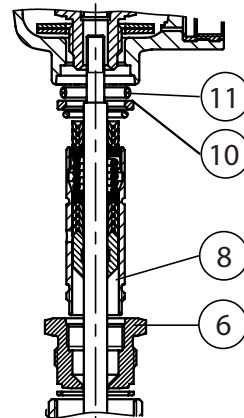

Actuator sizes E (R), F (R)

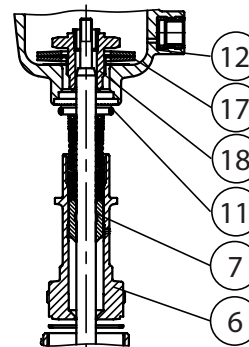

5 REPLACING THE SEAL SET

Concerns valves without label "R" in the actuator sizes: C (40 mm),
D (50 mm),
E (63 mm),
F (80 mm),
G (100 mm),
H (125 mm)

For valves with label "R" see chapter "6" on page 15.



DANGER!

Risk of injury from high pressure in the system.

- ▶ Before loosening lines or valves, switch off the pressure and bleed the lines.

Risk of injury due to improper maintenance work.

- ▶ Maintenance may be carried out by authorised technicians only.
- ▶ Use an open-end wrench, never a pipe wrench, to screw the valve body or actuator in or out.
- ▶ Observe tightening torques.

Required parts:

Item	Description
5	Graphite seal (packaged)
7	Scraper
11	O-ring
13	v-seals
21	O-ring
23	Piston seal

Item	Description
30	O-ring
32	O-ring (lip seal, actuator size C, without transparent cap)
36	O-ring (actuator size C)
37	Lip seal (actuator size C)
53	Prong ring (lip seal, actuator size C, without transparent cap)

NOTE!

To replace all seals, the actuator must be completely dismantled. A special Bürkert assembly sleeve is required for installation of the packing gland.



Do not use any pointed or sharp-edged auxiliary materials!

5.1 Disassembly

→ Tighten the valve on body ^①.

→ Only with control functions A and I: apply compressed air (5 bar) to the bottom pilot air port.

→ Unscrew the actuator at the nipple ^⑥ or pipe from valve body ^①.

→ Vent the actuator.

**CAUTION!**

Risk due to springs under tension.

▶ Open the piston actuator carefully!

→ Unscrew cover (31) with a special wrench, while pressing against the hexagon of actuator housing (12).



Information on the special wrench can be found in chapter [“10 Installation tools”](#).

→ Only for actuator sizes G and H: Remove washer (40).

→ Only for control function A: Remove compression springs (28) (29).

→ Uninstall position indicator (26) with Allen key.

→ Carefully tighten the actuator on swivel plate (3) (while only loading the upper part of the swivel plate).

→ Loosen nut (25).

→ Remove piston (22) with supporting washer (24).

→ Only for control function A: Remove filler piece (19) with intermediate washer (20) and O-ring (21).

→ Only for control function B: Remove intermediate washer (20), O-ring (21) and compression spring (35).

→ Only for control function I: Remove filler piece (19) with intermediate washer (20) and O-ring (21).

→ Remove spindle (2) from actuator housing (12) and clean spindle thread.

→ Clamp the actuator on the nipple or pipe hexagon (6).



For actuator size D, packing gland tube (8) is screwed and glued in nipple (6).

→ Loosen screw (18) with the socket wrench and remove it.

→ Remove disc springs (17).

→ Remove actuator housing (12).

→ Only for actuator size C: Replace O-ring (11).



Reinforcing ring (10) stays on packing gland tube (8).

→ Carefully slide the packing gland set (7), (13), (15), (16) out of the packing gland tube (8). Be careful not to damage the packing gland tube.

→ Thoroughly clean all single parts after disassembly.

5.2 Installation

Reassemble packing gland set as per the drawing.

- Grease the new wiper (7) (e.g. OKS 1110-3) and insert it into the packing gland tube (8).
- Grease the v-sleeves (13) thoroughly one by one (e.g. OKS 1110-3).
- **Only for actuator size C:** Assemble packing gland set (7, 13, 14, 15, 16) in the correct order (see detailed drawing) in packing gland tube (8).
- **Only for actuator sizes D, E, F, G, H:** Assemble packing gland set (7, 13, 15, 16) in the correct order (see detailed drawing) in packing gland tube (8).

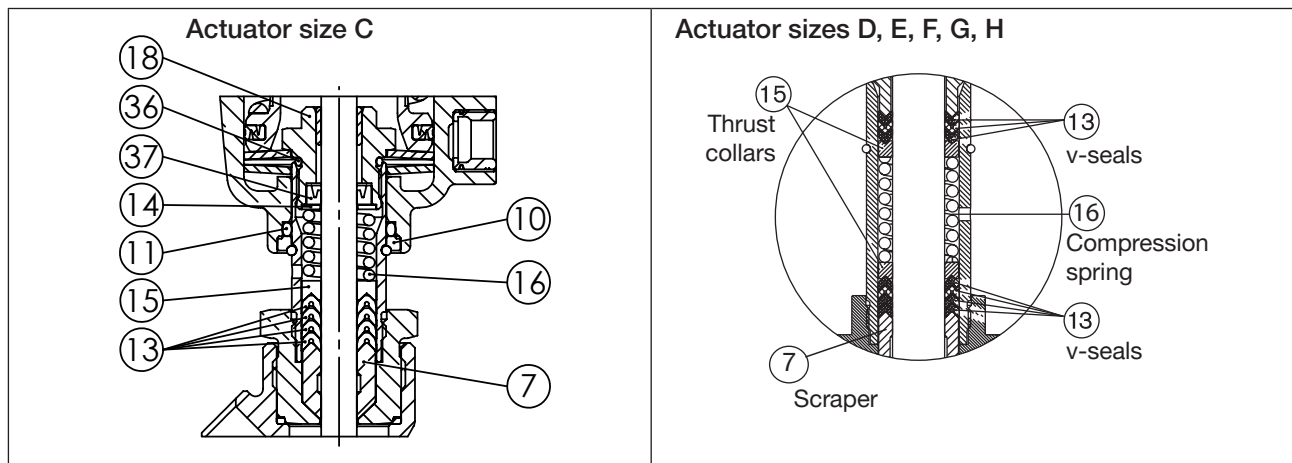

Image 2: Packing gland set actuator sizes C and D to H

- Press packing gland set into packing gland pipe (8) until the stop; tighten the nipple or tube (6) and screw in packing gland set with screw (18), remove screw (18).
- **Only for actuator size C:** Lightly grease the lip seal (37) (e.g. OKS 1110-3). Install lip seal and O-ring (36) on the screw.
- Place actuator housing (12), disc springs (17) and screw (18) onto packing gland tube (8).
- Screw together screw (18) with socket wrench, while noting the central position of disc springs (17).
- Lightly grease the spindle (2) (e.g. OKS 1110-3) and fit a suitable assembly sleeve over the spindle thread.



Information on the assembly sleeve can be found in chapter **“10 Installation tools”** of these instructions.

- Insert spindle into actuator through nipple or tube (6) and remove assembly sleeve.

Only for actuator size C:

- Control function A: Place intermediate washer (20) and O-ring (21) onto the spindle.
- Control function B: Place compression spring (35), intermediate washer (20) and O-ring (21) onto the spindle.

Only for actuator sizes D, E:

- Control function A and I: Place filler piece (19) and intermediate washer (20) onto the spindle.
- Control function B: Place compression spring (35) and intermediate washer (20) onto the spindle.

Only for actuator sizes F, G, H:

- Control function A and I: Place filler piece (19), intermediate washer (20) and O-ring (21) onto the spindle.
- Control function B: Place compression spring (35) and intermediate washer (20) onto the spindle.

Actuator sizes:

- Grease actuator housing surface (12) (e.g. OKS 1110-1).
- Remove old piston seal (23) from piston (22), clean groove and grease well (e.g. OKS 1110-1).
- Insert new piston seal (23).
- Only for actuator size C: Insert piston (22) and supporting washer (24).
- Only for actuator sizes D, E: Insert piston (22), slightly lubricated O-ring (21) and supporting washer (24).

Only for actuator sizes F, G, H:

- Control function A and I: Insert piston (22) and supporting washer (24).
- Control function B: Insert piston (22), slightly lubricated O-ring (21) and supporting washer (24).

Actuator sizes:

- Carefully tighten the actuator on swivel plate (3) (while only loading the upper part of the swivel plate).
- Apply adhesive (e.g. Loctite 274) to spindle thread (2) and tighten nut (25) with a wrench.
- Mount position indicator (26) (not for actuator size C).
- For control function A (CFA): Insert compression springs (28) (29).

- Only for actuator sizes G, H: Insert washer ④⑩.
- Only for control function B and I: Switch out O-ring ③⑩.
- Switch out O-ring ③②, unscrewing the transparent cap to do so.
- Only for actuator size C without transparent cap: Switch out prong ring ⑤③ and lip seal ③②.
- Lightly grease the cover thread (e.g. OKS 1110-1).
- Attach cover ③① and tighten with special wrench.
- Tighten valve body ①.

! Do not damage seal edges when replacing the seal!

- Replace graphite seal ⑤.
- Only for VA body: Grease the nipple or pipe thread ⑥ (e.g. Klüberpaste UH1 96-402).

NOTE!

Damage to seat contour!

- ▶ During installation make sure that the seat contour does not get damaged.
- ▶ Note tightening torque values according to “Table 1”.

- For control function A and I: Pressurise lower pilot air port with compressed air (5 bar).
- Screw nipple or tube ① with actuator into valve body ⑥, noting the tightening torque.
- Check valve for functionality and tightness.

Tightening torques for screwing the nipple or tube into the valve body

DN [mm]	Tightening torque [Nm]	DN [mm]	Tightening torque [Nm]
15	45	40	65
20	50	50	70
25	60	65	70
32	65		

Table 1: Tightening torques valve body

6 CHANGING THE PACKING GLAND

Concerns valves with label "R" in the actuator sizes: F (80 mm), G (100 mm), H (125 mm)

DANGER!

Risk of injury from discharge of pressure and escaping medium.

- ▶ Before cleaning, shut off the pressure and vent all lines!

The seal set for the packing gland includes:

Item	Description
13	Chevron seals (7 pc.)

Item	Description
7	Spindle guide

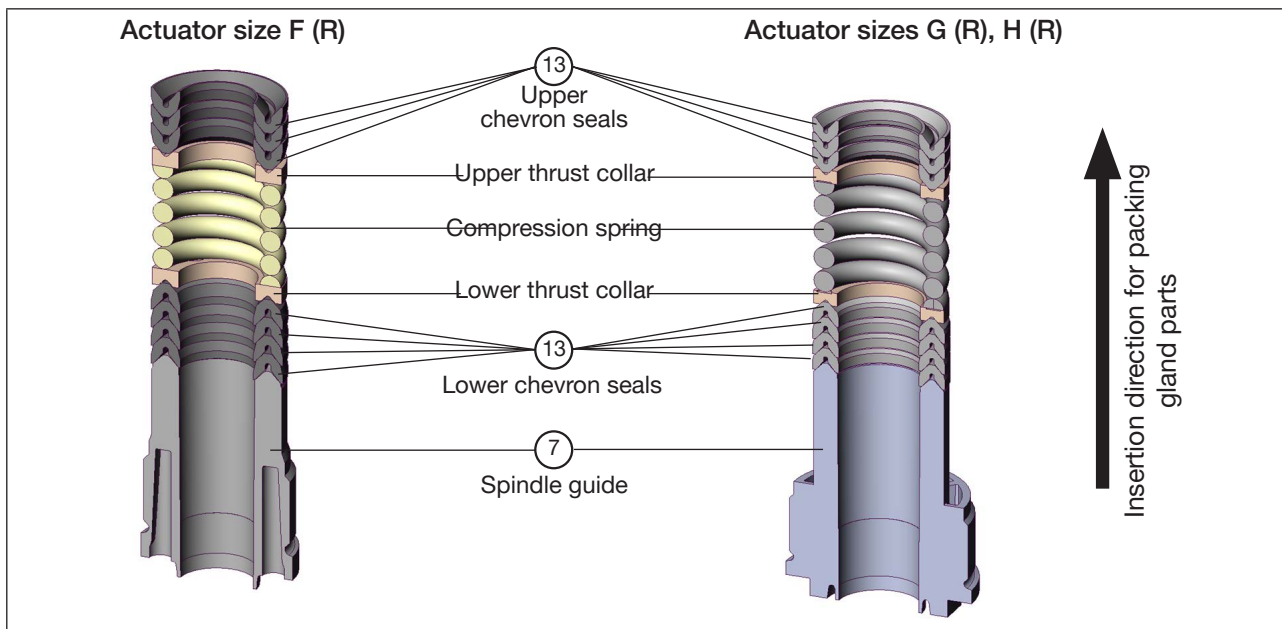

Image 3: Structure of the packing gland

WARNING!

Risk of injury due to using wrong tool.

- ▶ To remove the actuator from the valve body, use an open-end wrench, never a pipe wrench.
- ▶ To replace the packing gland, use special installation wrench (see chapter "10").
- ▶ Observe tightening torques.

NOTE!

To replace the packing gland, first remove the actuator from the valve body and remove the swivel plate.

Damage to seat contour!

► When removing the actuator, the valve must be in the open position.

- Clamp valve body ① in a collet (only for valves which have not yet been installed).
- For control function A and I: pressurise the bottom pilot air port with compressed air (5 bar): Valve opens.
- Place a suitable open-end wrench on the wrench flat of the nipple or tube ⑥.
- Unscrew actuator from valve body ①.
- Remove compressed air from pilot air port.
- Support swivel plate ③ with a prism, push out pin ④ with a suitable pin punch.
Pin punch \varnothing 3 mm for spindle diameter 10 mm and pin punch \varnothing 5 mm for spindle diameter 14 mm.
- Remove swivel plate ③.
- Only for actuator size F: Unscrew spindle guide ⑦ using the installation wrench and an open-end wrench.
- Only for actuator sizes G, H: Unscrew spindle guide ⑦ using 2 open-end wrenches.

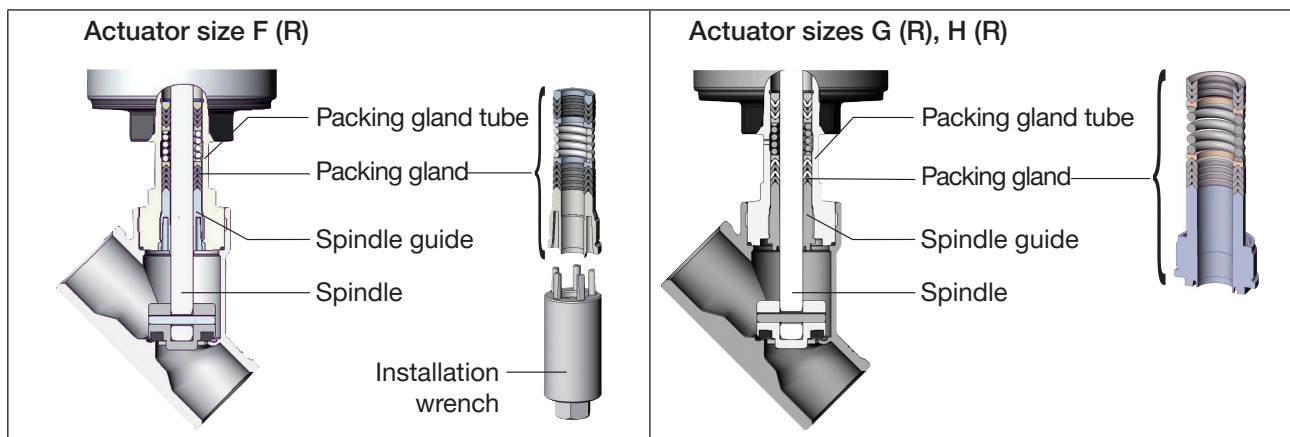

Image 4: Changing the packing gland

**WARNING!****Risk of injury due to parts being ejected!**

When the spindle opening is exposed, the individual parts of the packing gland will be pressed out at an undefined speed when the pilot air port is pressurised.

- ▶ Before pressurising with pilot air, safeguard the area around the outlet, (e.g. place spindle on a firm surface).

- Pressurise the lower pilot air port with 6–8 bar.
- Grease individual parts of the new packing gland with the supplied lubricant.
- Place individual parts on the spindle in the specified direction and sequence.
- Push the packing gland pack into packing gland tube ⑧.
- Screw the spindle guide back in. Observe the tightening torques according to “Table 2”!

Spindle diameter [mm]	Tightening torques [Nm]
10	6
14	15

Table 2: Tightening torques spindle guide

- Connect swivel plate ③ to spindle ②.
- Align boreholes in swivel plate ③ and spindle ②.
- Support swivel plate ③ on the cylindrical part using a prism or something similar.
- Insert pin ④ into the borehole.
- Caulk pin boreholes on both sides of swivel plate ③ using a chisel or centre punch.
- Tighten body ①.
- Replace graphite seal ⑤.
- **Only for VA body:** Grease the nipple thread ⑥ (e.g. Klüberpaste UH1 96-402).
- **For control function A and I:** Pressurise lower pilot air port with compressed air (5 bar).
- Screw the nipple or tube ⑥ with the actuator into the valve body ①. Observe the tightening torques.

Tightening torques for screwing the nipple or tube into the valve body

DN [mm]	Tightening torque [Nm]	DN [mm]	Tightening torque [Nm]
15	45	40	65
20	50	50	70
25	60	65	70
32	65		

Table 3: Tightening torques valve body

7 CHANGING THE PENDULUM DISC SET PROCESS VALVE



DANGER!

Risk of injury from high pressure in the system!

- ▶ Before loosening lines or valves, switch off the pressure and bleed the lines.

Risk of injury due to improper maintenance work!

- ▶ Maintenance may be carried out by authorised technicians only.
- ▶ Use an open-end wrench, never a pipe wrench, to screw the valve body or actuator in or out.
- ▶ Observe tightening torques.

Required parts:

Item	Description
3	Swivel plate with PTFE seal
4	Pin
5	Graphite seal (packaged)
3*	Sleeve (only valves with spindle diameter of 14 mm)

→ Tighten the valve on body ①.

→ For control function A and I: Pressurise lower pilot air port with compressed air (5 bar).

→ Unscrew actuator from valve body ①.

→ Vent the actuator.

→ Support swivel plate ③ with a prism, push out pin ④ with a pin punch and remove swivel plate.

→ Attach and align new swivel plate ③ and secure with new pin ④.

NOTE!

For valves with label "R", insert sleeve ③* into swivel plate and align drill holes.

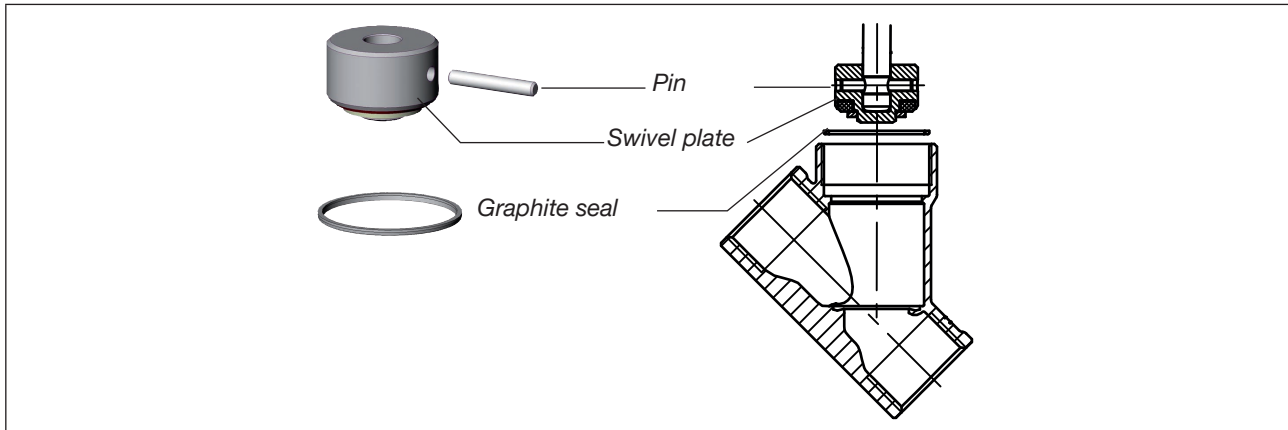

Image 5: Changing the valve set

- Caulk pin boreholes on both sides of the swivel plate using a chisel or centre punch.
- Carefully remove old graphite seal (5) from valve body (1).
- Insert new graphite seal (5).
- **Only for VA body:** Grease the nipple or tube thread (e.g. Klüberpaste UH1 96-402).

NOTE!

Damage to seat contour!

- ▶ During installation make sure that the seat contour does not get damaged.
- ▶ Note tightening torque values according to [“Table 4”](#).

- **For control function A and I:** Pressurise lower pilot air port with compressed air (5 bar).
- Screw valve actuator with nipple or tube (6) into the body.
- Check valve for functionality and tightness.

Tightening torques for screwing the nipple or tube into the valve body

DN [mm]	Tightening torque [Nm]
15	45
20	50
25	60
32	65

DN [mm]	Tightening torque [Nm]
40	65
50	70
65	70

Table 4: Tightening torques valve body

8 CHANGING THE VALVE SET (TYPE 2012)

Removing actuator from the valve body

→ Clamp valve body into a collet.

NOTE!

Damage to the seat seal or seat contour!

▶ When removing the actuator, the valve must be in the open position.

→ For control function A and I: pressurise the bottom pilot air port with compressed air (5 bar): Valve opens.

→ Place a suitable open-end wrench on the wrench flat of the nipple or tube.

→ Unscrew actuator from the valve body.

→ Carefully remove old graphite seal from the valve body.

Replacing valve seat

→ Unscrew the old valve seat with the assembly tool and a wrench.



Information on the assembly tool can be found in chapter [“10.3 Assembly tool for valve seat”](#).

→ Clean the thread and seal surface in the body with compressed air.

→ Select tool insert and screw it into the assembly tool.

→ Attach a new valve seat to the assembly tool.

→ Grease the thread with a lubricant (e.g. Klüberpaste UH1 96-402).

→ Manually screw the attached valve seat into the body thread.

→ Tighten to the specified tightening torque with a torque wrench (see [“Table 5”](#)).

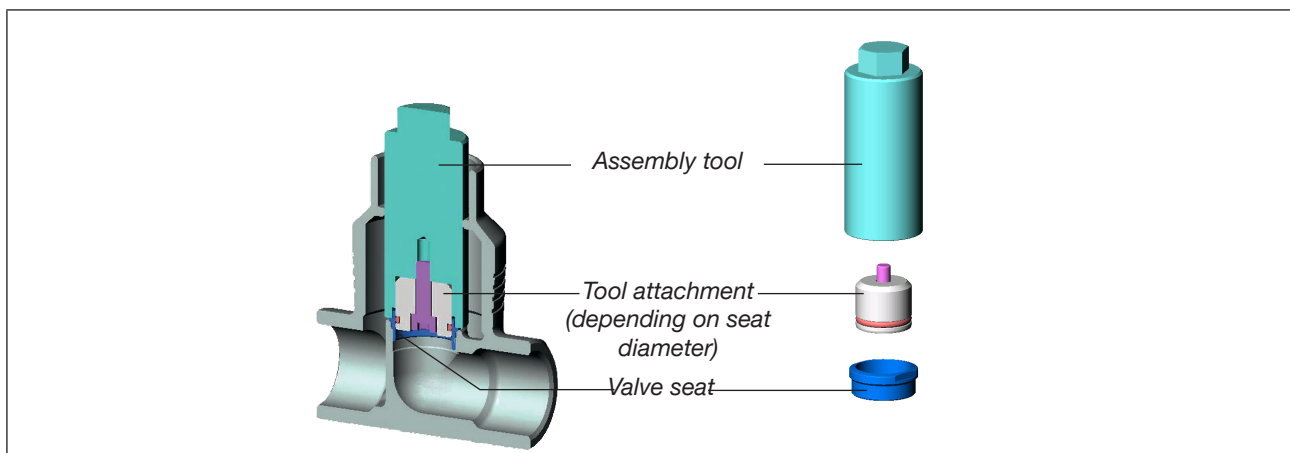

Image 6: Replacing the valve seat

Tightening torque values for seat assembly

Fitting		Tightening torques [Nm]		Tolerance [Nm]
DN valve seat [mm]	DN body [mm]	Uncoated valve seats	Coated valve seats	
4-15	15	25	20	+ 3
20	20	35	28	+ 3
25	25	50	40	+ 5
32	32	80	65	+ 5
40	40	100	85	+ 8
50	50	120	120	+ 8
65	65	150	150	+ 10
80	80	180	180	+ 10
100	100	220	220	+ 10

Table 5: Tightening torque values for seat assembly

9 CONVERTING CONTROL FUNCTION

9.1 Description of control functions

Depending on the variant, the seat of the valve is closed with or against the medium flow. Spring force (SFA) or pneumatic pilot pressure (SFB and SFI) generate the closing force on the swivel plate. The force is transmitted via a spindle connected to the actuator piston.



Exact descriptions of the control functions can be found in the Type 2000 operating instructions at: www.country.burkert.com

9.1.1 Control function A (CFA)

In the rest position, the valve is closed by spring force. By pressurising the lower control port, the seal is lifted from the valve seat and the flow is released. The open state is indicated by a position indicator located in the cover of the actuator.

9.1.2 Control function B (CFB)

In the depressurised state, the valve is opened by the spring force acting under the piston. When the upper control port is pressurised, the valve is closed by the pilot pressure acting on the piston.

9.1.3 Control function I (CFI)

The device works without spring force. The piston is alternatingly pressurised, namely at the lower pilot air port for opening and the upper for closing the valve.

9.1.4 Flow direction below seat

Depending on the variant, the valve is closed against the medium flow either with spring force (control function A, CFA) or pilot pressure (control function B, CFB).

As the medium is present under the swivel plate, the medium pressure contributes to the opening of the valve.

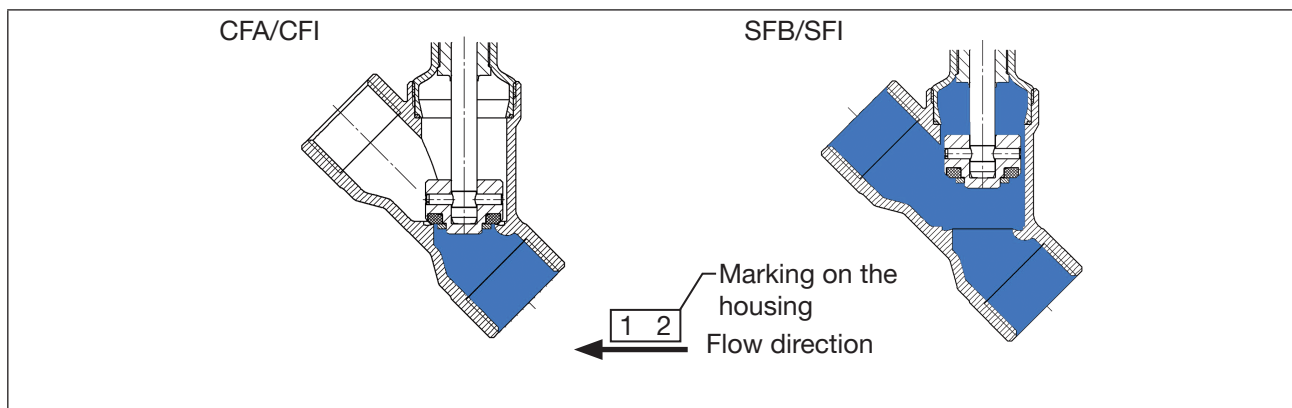

Image 7: Flow direction below seat (closing against medium)

9.1.5 Flow above seat

The valve is closed by spring force (control function A, SFA) with the medium flow. As the medium pressure is applied over the swivel plate, it supports the closing process of the valve and additionally contributes to sealing the valve seat.

The valve opens through pilot pressure.

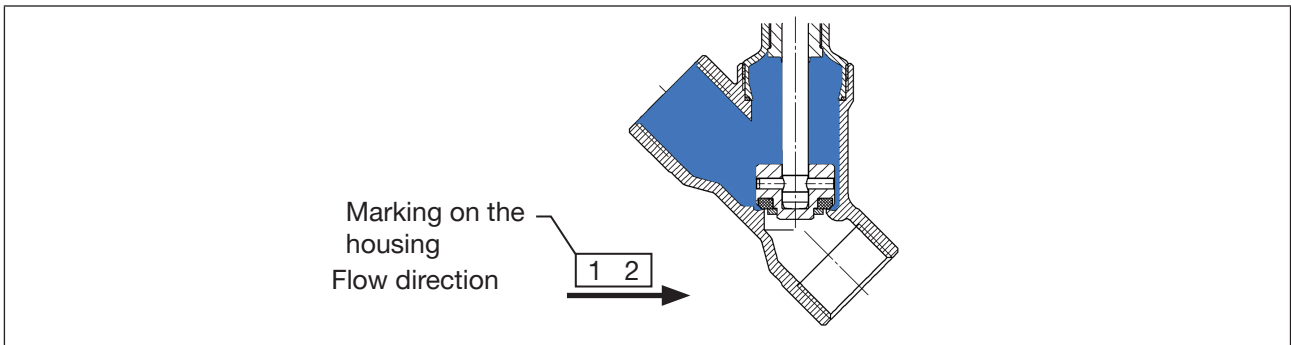

Image 8: Flow direction above the seat (closing with the medium)

9.2 Conversion from control function A (CFA) to B (CFB)

DANGER!

Danger from high pressure!

- ▶ Before loosening lines or valves, switch off the pressure and bleed the lines.

Risk of injury due to improper maintenance work!

- ▶ Maintenance may be carried out by authorised technicians only!
- ▶ Use an open-end wrench, never a pipe wrench, to screw the valve body or actuator in or out.
- ▶ Observe tightening torques.

Required parts:

Item	Description
35	Compression spring
30	O-ring
5	Graphite seal

→ Tighten the valve on body ⁽¹⁾.

→ Pressurise lower pilot air port with compressed air (5 bar).

→ Unscrew actuator at nipple or tube ⁽⁶⁾ from the valve body ⁽¹⁾.

→ Vent the actuator.

CAUTION!

Risk due to springs under tension!

- ▶ Open the piston actuator carefully!

→ Unscrew cover ⁽³¹⁾ with a special wrench, while pressing against the hexagon of actuator housing ⁽¹²⁾.



Information on the special wrench can be found in chapter [“10 Installation tools”](#).

→ Only for actuator sizes G, H: Remove washer ⁽⁴⁰⁾.

→ Remove compression springs ⁽²⁸⁾ ⁽²⁹⁾.

→ Uninstall position indicator ⁽²⁶⁾ with Allen key.

→ Carefully tighten the actuator on swivel plate ⁽³⁾ (while only loading the upper part of the swivel plate).

→ Loosen nut ⁽²⁵⁾.

→ Remove piston ⁽²²⁾ with supporting washer ⁽²⁴⁾.

→ Remove filler piece ⁽¹⁹⁾ with intermediate washer ⁽²⁰⁾ and O-ring ⁽²¹⁾ (the filler piece is not needed for CFB).

- Only for actuator sizes G or H with label "R" on the type label: Insert spring restraint (34).
- Insert new compression spring (35).
- Place intermediate washer (20), and also the slightly lubricated O-ring (21) for actuator size C, onto the spindle.
- Insert piston (22), slightly lubricated O-ring (21) (only for actuator size D and H) and supporting washer (24).
- Apply adhesive (e.g. Loctite 274) to spindle thread (2) and tighten nut (25).
- Mount position indicator (26).
- Insert new O-ring (30) into the groove of the actuator housing.

! Do not damage seal edges when replacing the seal!

- Only for actuator sizes G, H: Insert washer (40).
- Attach cover (31) and tighten with special wrench.
- Replace graphite seal (5).
- Only for VA body: Grease the nipple or pipe thread (6) (e.g. Klüberpaste UH1 96-402).
- Tighten body (1).

NOTE!

Damage to seat contour!

- ▶ During installation make sure that the seat contour does not get damaged.
- ▶ Note tightening torque values according to "Table 6".

- Screw nipple (6) with actuator into valve body (1).
- Check valve for functionality and tightness.

Tightening torques:

Material Nipple thread	DN [mm]	Tightening torque [Nm]
Brass or stainless steel	15	45
	20	50
	25	60
	32	65
	40	65
	50	70
	65	70

Table 6: Tightening torques

MAN 1000080125 ML Version: T Status: RL (released | freigegeben) printed: 16.02.2026

9.3 Conversion from control function A (CFA) to I (CFI)

DANGER!

Danger from high pressure!

- ▶ Before loosening lines or valves, switch off the pressure and bleed the lines.

Risk of injury due to improper maintenance work!

- ▶ Maintenance may be carried out by authorised technicians only!
- ▶ Use an open-end wrench, never a pipe wrench, to screw the valve body or actuator in or out.
- ▶ Observe tightening torques.

Required parts:



Items	Description
30	O-ring

→ Tighten the valve on body .

CAUTION!

Risk due to springs under tension!

- ▶ Open the piston actuator carefully!

→ Unscrew cover  with a special wrench, while pressing against the hexagon of actuator housing .



Information on the special wrench can be found in chapter [“10 Installation tools”](#).

→ For actuator size G (100 mm) and H (125 mm): Remove washer .

→ Remove compression springs  .

→ Insert O-ring  into the groove of the actuator housing.

→ For actuator size G (100 mm) and H (125 mm): Insert washer .

→ Attach cover  and tighten with special wrench.

→ Check valve for functionality and tightness.



For control function I (CFI), connect both pilot air ports to the pilot lines.

9.4 Conversion from flow direction above the seat to flow direction below seat.

DANGER!

Danger from high pressure!

- ▶ Before loosening lines or valves, switch off the pressure and bleed the lines.

Risk of injury due to improper maintenance work!

- ▶ Maintenance may be carried out by authorised technicians only!
- ▶ Use an open-end wrench, never a pipe wrench, to screw the valve body or actuator in or out.
- ▶ Observe tightening torques.

Required parts:

Items	Description
28, 29	1 or 2 compression springs

→ Tighten the valve on body .

CAUTION!

Risk due to springs under tension!



- ▶ Open the piston actuator carefully!

→ Unscrew cover  with a special wrench, while pressing against the hexagon of actuator housing .





Information on the special wrench can be found in chapter [“10 Installation tools”](#).

→ For actuator size G (100 mm) and H (125 mm): Remove washer .

→ Remove and/or insert compression springs   depending on actuator.

→ Only for actuator size C, D, E, F: Remove compression springs and insert new, stronger springs.

→ Only for actuator sizes G, H: install new outer spring  in addition to present inner spring .

→ For actuator size G (100 mm) and H (125 mm): Insert washer .

→ Attach cover  and tighten with special wrench.

→ Check valve for functionality and tightness.



Note changed flow direction and pressure range!

9.5 Conversion from flow direction below seat to flow direction above the seat

DANGER!

Danger from high pressure!

- ▶ Before loosening lines or valves, switch off the pressure and bleed the lines.

Risk of injury due to improper maintenance work!

- ▶ Maintenance may be carried out by authorised technicians only!
- ▶ Use an open-end wrench, never a pipe wrench, to screw the valve body or actuator in or out.
- ▶ Observe tightening torques.

Required parts:



Items	Description
28, 29	2 compression springs for actuators C, D, E, F

→ Tighten the valve on body .

CAUTION!

Risk due to springs under tension!



- ▶ Open the piston actuator carefully!

→ Unscrew cover  with a special wrench, while pressing against the hexagon of actuator housing .



Information on the special wrench can be found in chapter “[10 Installation tools](#)”.

→ For actuator size G (100 mm) and H (125 mm): Remove washer .

→ Remove and/or insert compression springs   depending on actuator.

→ Only for actuator sizes C, D, E, F: Remove compression springs and insert new, weaker springs.

→ Only for actuator sizes G, H: only remove outer  spring, inner spring  remains in the actuator.

→ For actuator size G (100 mm) and H (125 mm): Insert washer .

→ Attach cover  and tighten with special wrench.

→ Check valve for functionality and tightness.



Note changed flow direction and pressure range.

10 INSTALLATION TOOLS

10.1 Assembly wrench for actuator cover

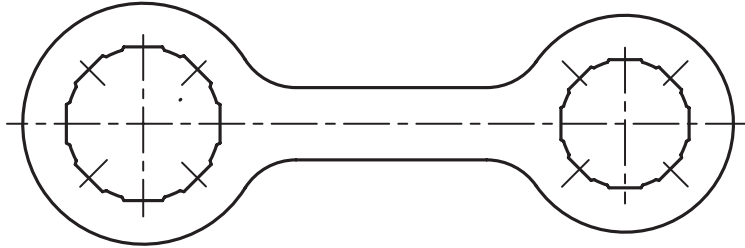

Assembly wrench actuator size C, D

Actuator	ø [mm]	Order number
C	40	639 175
D	50	639 175

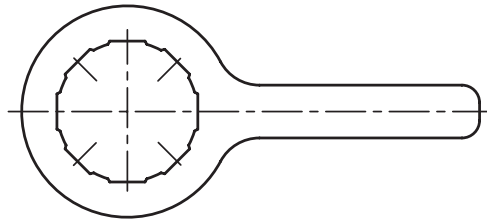

Assembly wrench actuator size E

Actuator	ø [mm]	Order number
E	63	639 170

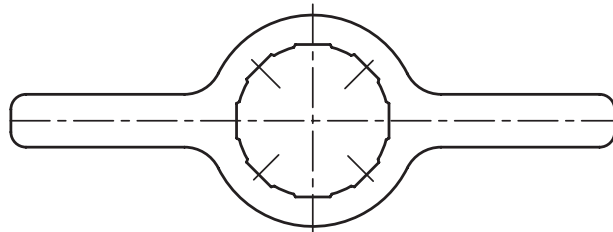

Assembly wrench actuator size F, G, H

Actuator	ø [mm]	Order number
F	80	639 171
G	100	639 172
H	125	639 173

10.2 Assembly tools for packing gland

10.2.1 Assembly sleeve

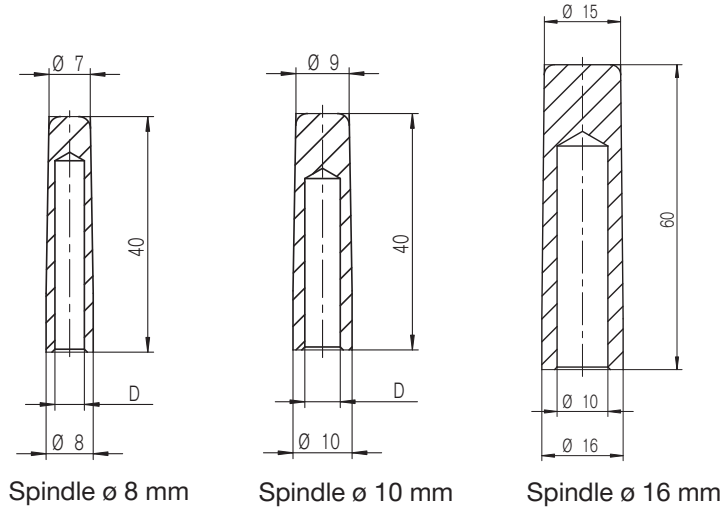

Assembly sleeve for spindle \varnothing 8 mm			
Actuator	DN	Dimension D [mm]	Order number
C (40 mm)	15, 20	\varnothing 5	639 165
D (50 mm)	15, 20, 25	\varnothing 6	639 166

Assembly sleeve for spindle \varnothing 10 mm			
Actuator	DN	Dimension D [mm]	Order number
E (63 mm)	20, 25, 32, 40, 50	\varnothing 6	639 167
F (80 mm)	25, 32, 40, 50, 65	\varnothing 8	639 168

Assembly sleeve for spindle \varnothing 16 mm			
Actuator	DN	Dimension D [mm]	Order number
G (100 mm)	32, 40, 50, 65	–	639 169
H (125 mm)	32, 40, 50, 65	–	639 169

10.2.2 Installation wrench

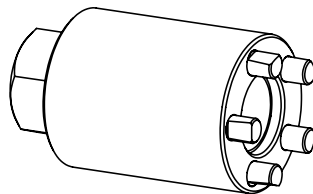

Assembly wrench for packing gland for valves with label "R" on the type label (only disassembly of packing glands until January 2013)			
Actuator	\varnothing [mm]	Spindle \varnothing [mm]	Order number
G	100	14	665 701
H	125	14	665 701

Modified socket wrench for packing gland (Series-production status as of January 2013)					
	Actuator	ø [mm]	Spindle ø [mm]	AF	Order number
	G	100	14	21	683 223
	H	125	14	21	683 223

Table 7: Modified socket wrench

10.3 Assembly tool for valve seat

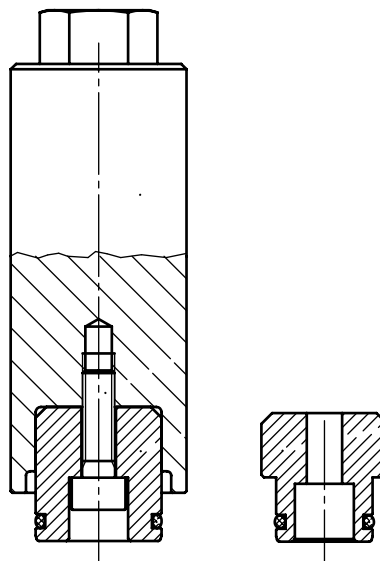

Assembly tool for valve seat Type 2012			
Actuator	ø [mm]	DN valve seat [mm]	Order number
		10/15	652 604
		20	652 605
		25	652 606
		32	652 607
		40	652 608
		50	652 609
K	175	65	655 562
K, L	175, 225	80	655 563
K, L	175, 225	100	655 564

MAN 1000080125 ML Version: T Status: RL (released | freigegeben) printed: 16.02.2026

11 PARTS ORDER

CAUTION!

Risk of injury and/or damage due to incorrect parts!

Incorrect accessories and unsuitable spare parts may cause injuries and damage the device and the area around it.

► Use only original accessories and original spare parts from Bürkert.

11.1 Replacement part sets

Type 2000

- Seal set for actuator
consisting of the seal and wearing parts of the actuator.
- Valve set (Type 2000)
consisting of swivel plate, pin and graphite seal.

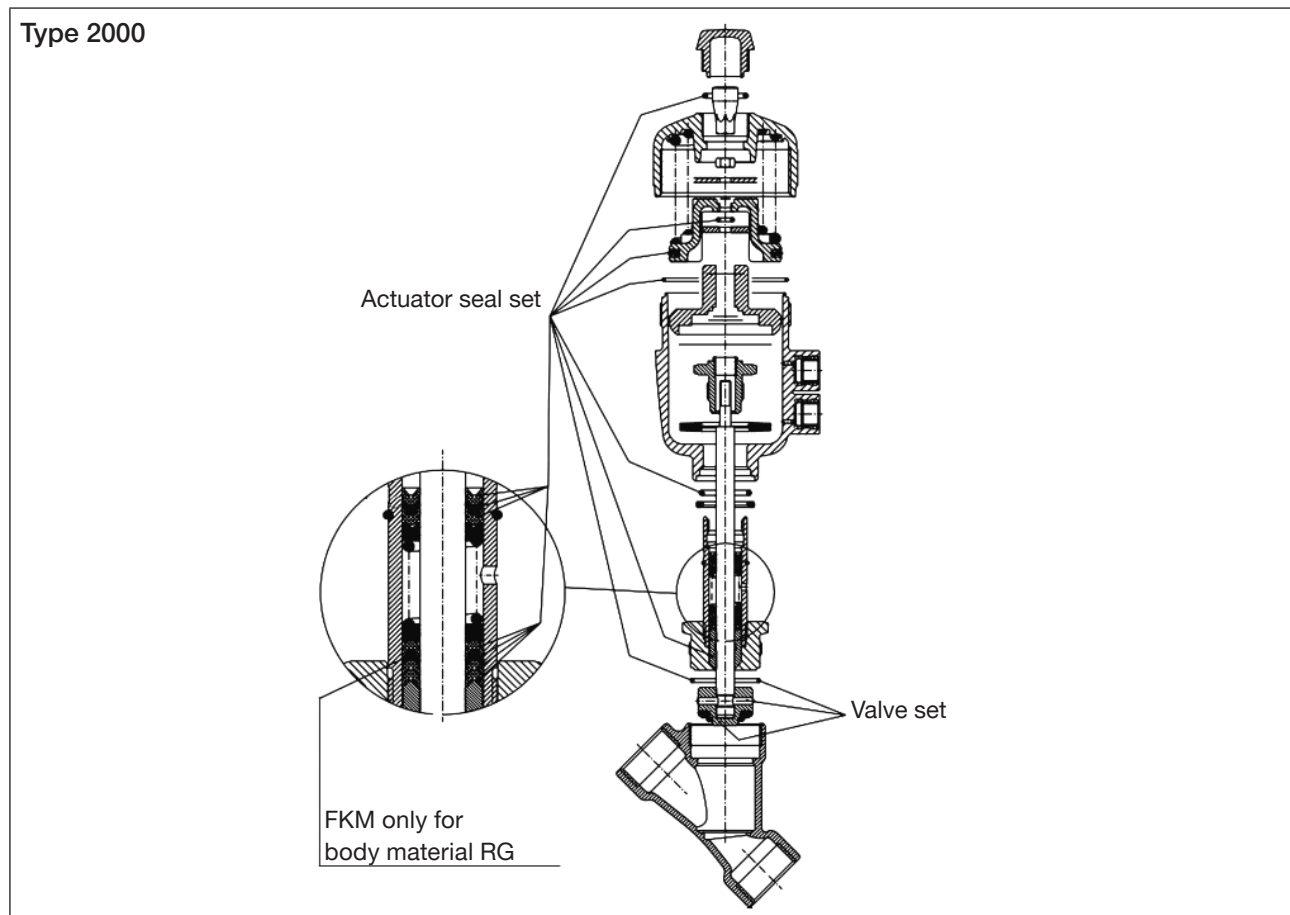

Image 9: Spare part sets type 2000

Type 2006

- Valve set (type 2006) consisting of spindle with counterholder, seals, seal holder, nut and graphite seals.

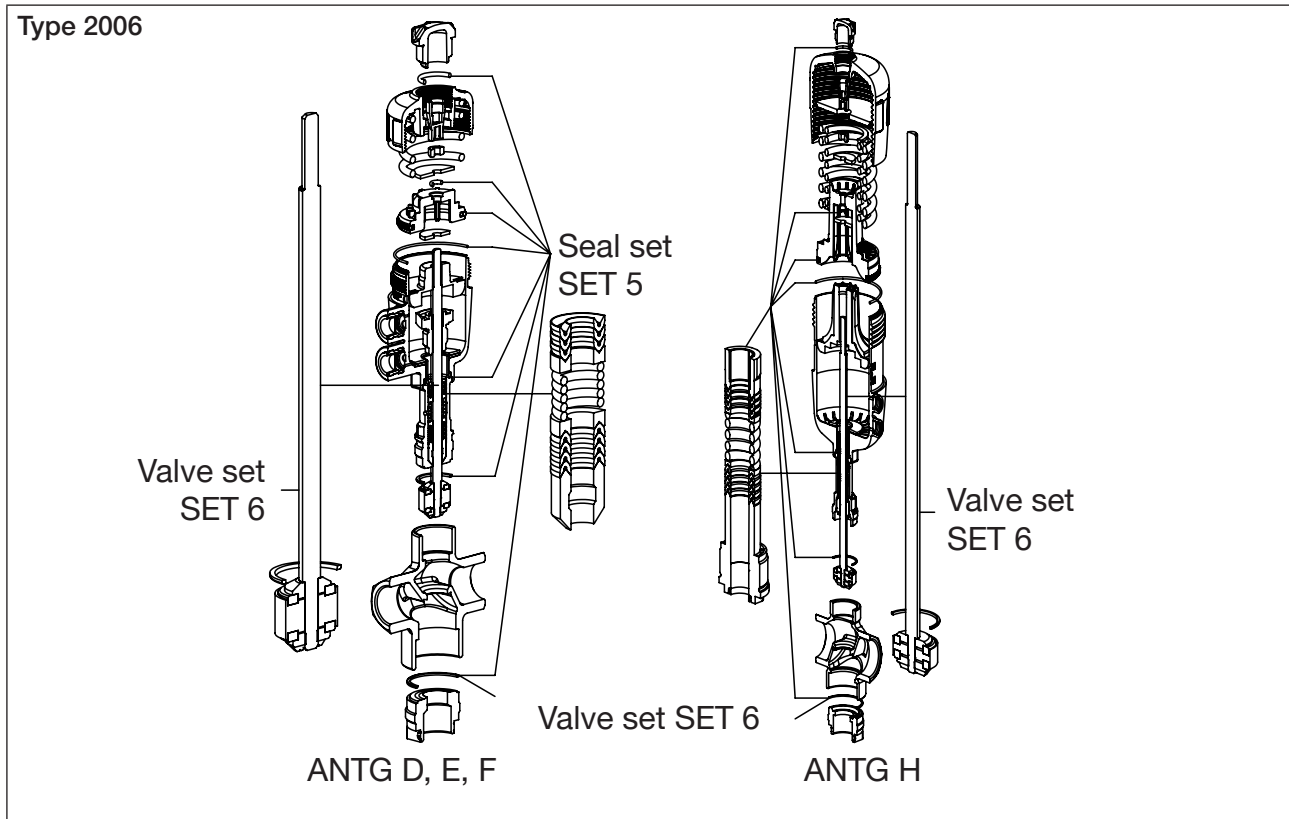

Image 10: Spare part sets type 2006

Type 2012, actuator size C to H (40–125 mm)

- Seal set for actuator
consisting of the seal and wearing parts of the actuator.
- Valve set
consisting of swivel plate, pin and graphite seal.
- Valve trim
consisting of swivel plate, pin, graphite seal and valve seat

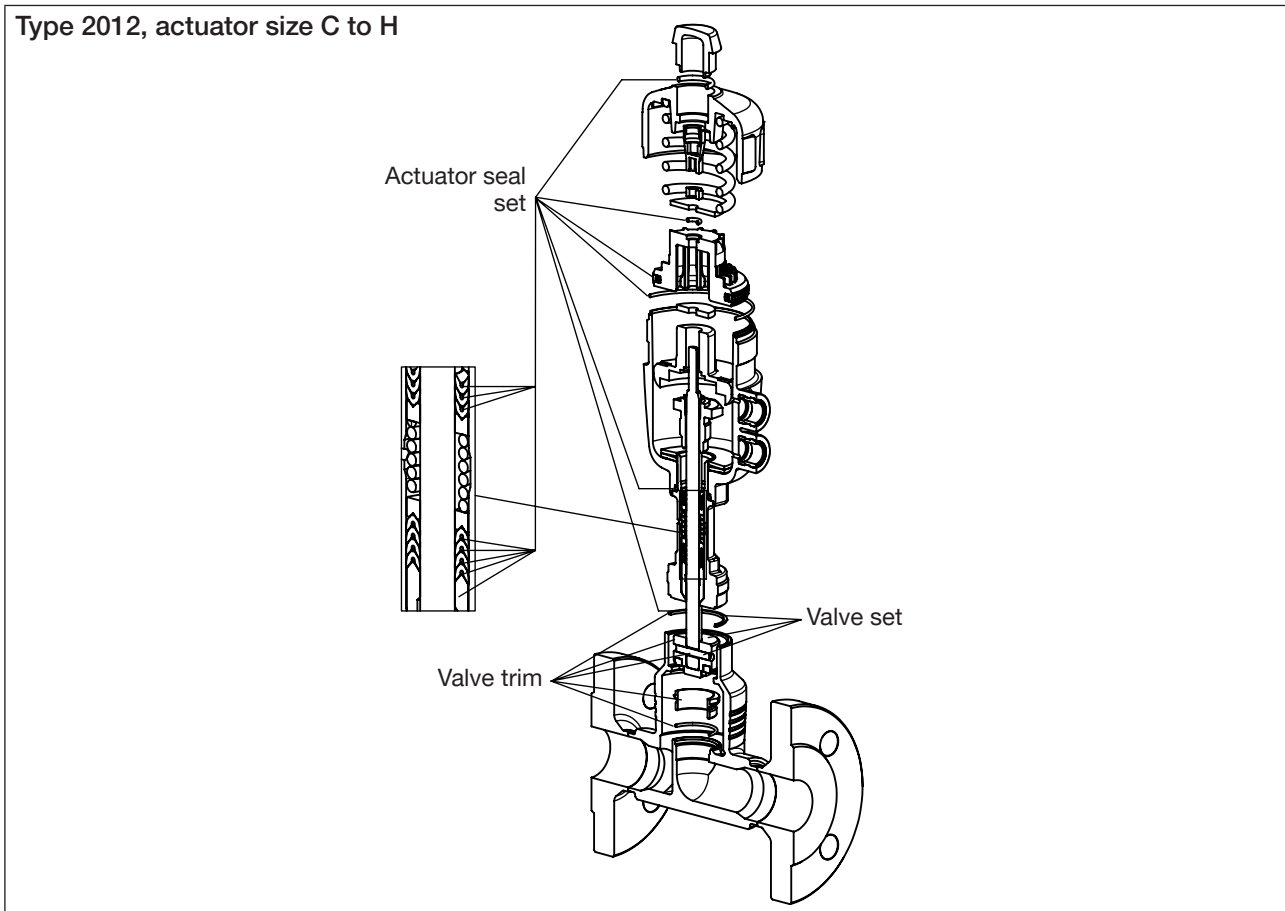

Image 11: Spare part sets Type 2012, actuator size C to H (40–125 mm)

Type 2012, actuator size K (175 mm), L (225 mm)

- Packing gland seal set
consisting of wearing parts of packing gland, graphite seal.
- Valve set
consisting of swivel plate, pin and graphite seal.
- Valve trim
consisting of swivel plate, pin, graphite seal and valve seat.
- Swivel plate seal set
consisting of graphite seal, pin and seal plate PTFE.

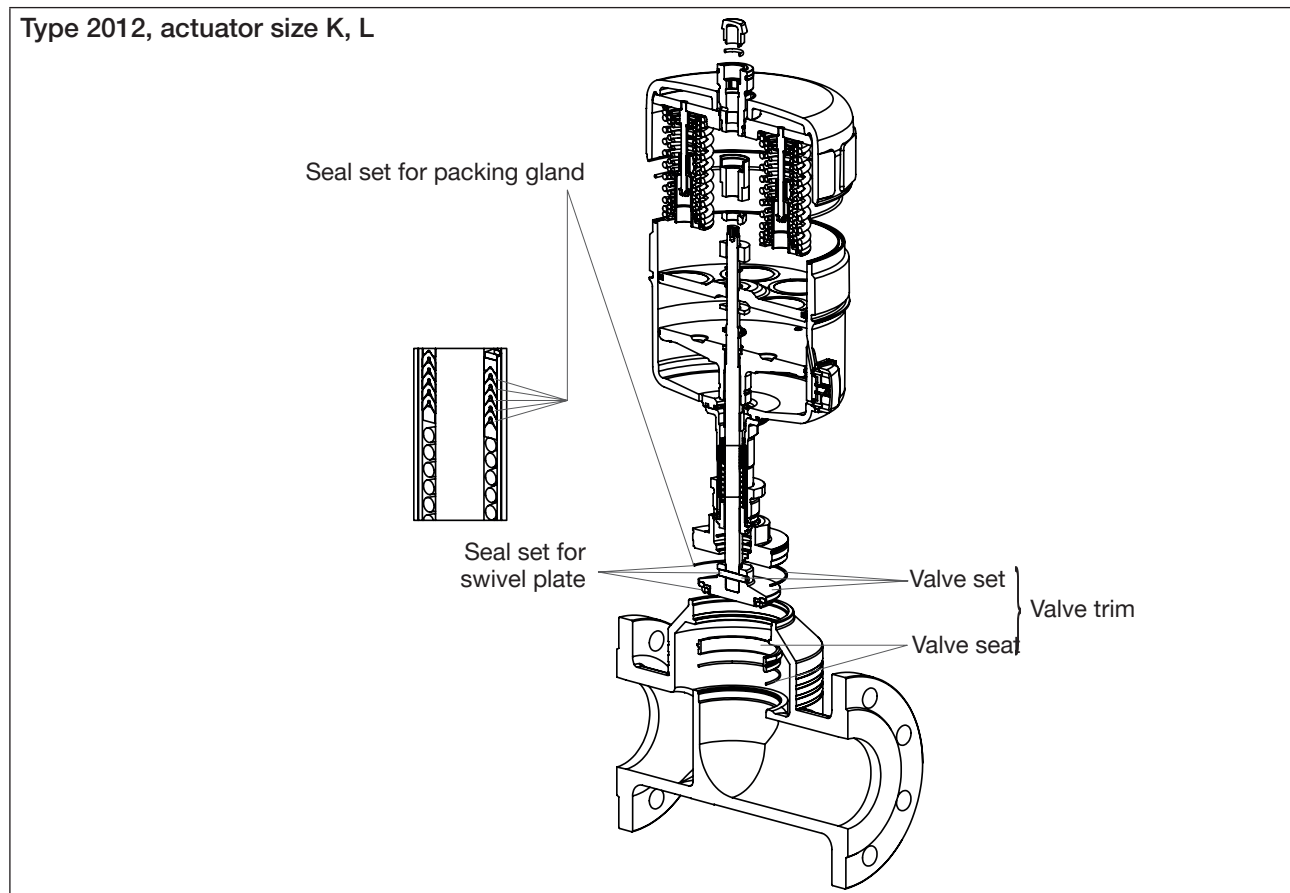

Image 12: Spare part sets Type 2012, actuator size K (175 mm), L (225 mm)

11.1.1 Actuator seal set

Seal set (SET 5) PPS actuator:

Actuator size		DN valve seat [mm]	Order number Standard	Order number Water variant ¹⁾	Order number High temperature variant ²⁾
Designation	ø [mm]				
C	40	15/20/25	233 581	–	–
D	50	15/20/25	233 582	383 139	–
E	63	25–50	233 583	383 140	383 144
F	80	25–65	233 584	383 141 ³⁾	383 145
G	100	32–65	233 585	383 142 ³⁾	383 146
H	125	40–65	233 586	383 143 ³⁾	383 147
H	125	80–100	276130	–	–

Seal set (SET 5) PA actuator:

Actuator size		DN valve seat [mm]	Order number
Designation	ø [mm]		
C	40	15/20/25	233 587
D	50	15/20/25	233 588
E	63	25–50	233 591
F	80	25–65	233 593
G	100	32–65	233 594
H	125	40–65	233 596
H	125	80–100	276132

- 1) Water variant up to +200°C
 2) High temperature variant up to +230°C
 3) Up to nominal diameter DN50 valve seat

11.1.2 Swivel plate set process valve

RG variant, SET 6 (2/2-way valve type 2000):

DN valve seat [mm]	Actuator size (\varnothing [mm])	Order number (PTFE seal)	Order number (FKM seal)
15		010 984	011 065
20		010 986	011 070
25	50	010 988	011 085
25	63, 80	159 635	277 105
32		011 044	011 088
40		011 046	011 107
50		233 819	233 821
65		233 820	233 822

Table 8: SET 6 – valve set RG body type 2000

VA variant, SET 6 (2/2-way valve type 2000, 2012):

DN valve seat [mm]	Actuator size (\varnothing [mm])	Order number (PTFE seal)	Order number (FKM seal)	Order number (PEEK seal)
10		220 053	–	–
15 ⁴⁾		149 606	230 907	–
15 ⁵⁾		011 134	011 234	235 782
20		011 171	011 253	235 783
25	50	011 202	011 259	–
25	63, 80	160 737	168 816	235 786
32		011 208	011 262	235 787
40		011 209	011 267	235 788
50		233 813	233 817	235 790
65		233 815	233 818	–
65	175	155 491	–	–
80	175, 225	155 492	–	–
100	175, 225	155 493	–	–

Table 9: Set 6 – valve set VA body

⁴⁾ only Type 2012

⁵⁾ only Type 2000

SET6 (3/2-way valve type 2006)

Actuator size (\varnothing [mm])	DN valve seat [mm]	Order number (PTFE seal)
50	15/20	288 384
63	15/20	288 386
63	25	288 392
80	32/40	288 393
125	32/40	288 394
63	32/40	288 395
125	50	288 399

Table 10: SET 6 - globe valve type 2006

11.1.3 Valve trim (Type 2012)

Actuator size (\varnothing [mm])	DN valve seat [mm]	Order number (PTFE seal)
32	10/15	149 608
	20	149 864
50	25	161 376
63	25	149 786
	32	149 787
	40	149 788
	50	237 390
	65	237 391
175	65	155 487
175, 225	80	155 488
175, 225	100	155 489

11.1.4 Seal set swivel plate (Type 2012)

Actuator size (\varnothing [mm])	DN valve seat [mm]	Order number
175, 225	80	155 494
175, 225	100	155 495

11.1.5 Seal set packing gland (Type 2012)

Actuator size		DN valve seat [mm]	Order number
Designation	\varnothing [mm]		
K	175	65	353 575
K, L	175, 225	80	353 575
K, L	175, 225	100	353 575

11.2 Conversion sets type 2000 and 2012

11.2.1 Conversion set for switching from CFA to CFB or CFI

Designation	Actuator size		Order number
		ø [mm]	
C		40	229 900
D		50	012 090
E		63	011 946
F		80	011 955
G		100	011 957
G(R)		100	276 318
H		125	011 964
H(R)		125	276 319

11.2.2 Conversion set for switching from flow direction above the seat to flow direction below seat

Designation	Actuator size		Order number
		ø [mm]	
D		50	012 016
E		63	012 023
F		80	012 029
G		100	012 071
H		125	012 086

11.2.3 Conversion set for switching from flow direction below seat to flow direction above the seat

Designation	Actuator size		Order number
		ø [mm]	
D		50	011 985
E		63	012 124
F		80	012 005
G		100	Only remove outer springs
H		125	

