

# Type 2000 INOX

2/2-way angle seat valve  
2/2-Wege Schrägsitzventil  
Vanne à siège incliné 2/2 voies

## Operating Instructions

Bedienungsanleitung  
Manuel d'utilisation



We reserve the right to make technical changes without notice.  
Technische Änderungen vorbehalten.  
Sous réserve de modifications techniques.

© Bürkert Werke GmbH & Co. KG, 2010 - 2018

Operating Instructions 1805/04\_EU-ML\_00805856 / Original DE

<b>1</b>	<b>THE OPERATING INSTRUCTIONS</b> .....	<b>4</b>	<b>8</b>	<b>ASSEMBLY</b> .....	<b>10</b>
1.1	Symbols.....	4	8.1	Safety instructions.....	10
1.2	Definition of the term 'Device' .....	4	8.2	Before installation.....	11
<b>2</b>	<b>AUTHORIZED USE</b> .....	<b>5</b>	8.3	Installation .....	11
<b>3</b>	<b>BASIC SAFETY INSTRUCTIONS</b> .....	<b>5</b>	8.4	Pneumatic connection.....	13
<b>4</b>	<b>GENERAL INFORMATION</b> .....	<b>6</b>	<b>9</b>	<b>START-UP</b> .....	<b>14</b>
4.1	Contact address.....	6	9.1	Safety instructions.....	14
4.2	Warranty .....	6	<b>10</b>	<b>MAINTENANCE, CLEANING</b> .....	<b>15</b>
4.3	Information on the Internet .....	6	10.1	Safety instructions.....	15
<b>5</b>	<b>PRODUCT DESCRIPTION</b> .....	<b>7</b>	10.2	Maintenance work .....	15
5.1	General description .....	7	10.3	Cleaning .....	15
5.2	Properties .....	7	10.4	Recommended auxiliary materials .....	15
<b>6</b>	<b>TECHNICAL DATA</b> .....	<b>7</b>	<b>11</b>	<b>REPAIRS</b> .....	<b>16</b>
6.1	Conformity.....	7	11.1	Replacing the valve set .....	16
6.2	Standards .....	7	<b>12</b>	<b>MALFUNCTIONS</b> .....	<b>19</b>
6.3	Operating conditions.....	7	<b>13</b>	<b>SPARE PARTS</b> .....	<b>20</b>
6.4	General technical data.....	9	<b>14</b>	<b>TRANSPORTATION, STORAGE, DISPOSAL</b> .....	<b>21</b>
<b>7</b>	<b>STRUCTURE AND FUNCTION</b> .....	<b>10</b>			
7.1	Structure.....	10			
7.2	Function.....	10			

# 1 THE OPERATING INSTRUCTIONS

The operating instructions describe the entire life cycle of the device. Keep these instructions in a location which is easily accessible to every user and make these instructions available to every new owner of the device.

## The operating instructions contain important safety information!

Failure to observe these instructions may result in hazardous situations.

- ▶ The operating instructions must be read and understood.

## 1.1 Symbols



### DANGER!

Warns of an immediate danger!

- ▶ Failure to observe the warning will result in a fatal or serious injury.



### WARNING!

Warns of a potentially dangerous situation!

- ▶ Failure to observe the warning may result in serious injuries or death.



### CAUTION!

Warns of a possible danger!

- ▶ Failure to observe this warning may result in a moderate or minor injury.

### NOTE!

Warns of damage to property!

- ▶ Failure to observe the warning may result in damage to the device or the equipment.



Indicates important additional information, tips and recommendations.



Refers to information in these operating instructions or in other documentation.

→ Designates a procedure which you must carry out.

## 1.2 Definition of the term 'Device'

In these instructions, the term "device" always refers to the angle seat valve Type 2000 INOX.

## 2 AUTHORIZED USE

**Non-authorized use of the angle seat valve Type 2000 INOX (designated as device in the following) can be dangerous to people, nearby equipment and the environment.**

- ▶ The device is designed for the controlled flow-rate of liquid and gaseous media.
- ▶ In the potentially explosion-risk area the device may be used only according to the specification on the separate Ex type label. For use observe the additional information enclosed with the device together with safety instructions for the explosion-risk area.
- ▶ Devices without a separate Ex type label may not be used in a potentially explosive area.
- ▶ Use according to the authorized data, operating conditions, and conditions of use specified in the contract documents and operating instructions. These are described in chapter "[6. Technical data](#)".
- ▶ Use the device only in conjunction with third-party devices and components recommended and authorized by Bürkert.
- ▶ Correct transportation, storage, and installation, as well as careful use and maintenance are essential for reliable and faultless operation.
- ▶ Use the device only as intended.

## 3 BASIC SAFETY INSTRUCTIONS

These safety instructions do not make allowance for any

- Contingencies and events which may arise during the installation, operation, and maintenance of the devices.
- Local safety regulations – the operator is responsible for observing these regulations, also in relation to the installation personnel.



### **Danger – high pressure!**

- ▶ Turn off the pressure and vent the lines before loosening lines or valves.

### **Risk of crushing from moving pneumatic connection!**

- ▶ When opening and closing the device, do not touch the moving pneumatic connection.
- ▶ Do not reach into the area immediately above and below the control air connection.

### **Risk of water hammer when flow inlet over seat!**

- When flow inlet over seat, do not use angle seat valve for liquid media due to the risk of water hammer.

### **Risk of burns/risk of fire if used during long-term operation through hot device surface!**

- ▶ Do not touch the device with bare hands.
- ▶ Keep the device away from highly flammable substances and media.

### General hazardous situations.

To prevent injuries:

- Supply only media to the media connections which have been specified as flow media in the chapter "Technical Data".
- ▶ Do not physically stress the housing (e.g. by placing objects on it or standing on it).
- ▶ Ensure that the system cannot be activated unintentionally.
- ▶ Only trained technicians may perform installation and maintenance work.
- ▶ After an interruption in the power supply or pneumatic supply, ensure that the process is restarted in a defined or controlled manner.
- ▶ The device may be operated only when in perfect condition and in consideration of the operating instructions.
- ▶ The general rules of technology apply to application planning and operation of the device.



The angle seat valve Type 2000 INOX was developed with due consideration given to the accepted safety rules and is state-of-the-art. Nevertheless, dangerous situations may occur.

## 4 GENERAL INFORMATION

### 4.1 Contact address

#### Germany

Bürkert Fluid Control Systems  
Sales Center  
Christian-Bürkert-Str. 13-17  
D-74653 Ingelfingen  
Germany  
Tel. + 49 (0) 7940 - 10 91 111  
Fax + 49 (0) 7940 - 10 91 448  
Email: [info@burkert.com](mailto:info@burkert.com)

#### International

Contact addresses can be found on the final pages of the printed operating instructions.

And also on the Internet at: [www.burkert.com](http://www.burkert.com)

### 4.2 Warranty

The warranty is only valid if the device is used as intended in accordance with the specified application conditions.

### 4.3 Information on the Internet

The operating instructions and data sheets for Type 2000 INOX can be found on the Internet at: [www.burkert.com](http://www.burkert.com)

## 5 PRODUCT DESCRIPTION

### 5.1 General description

The 2/2-way angle seat valve Type 2000 INOX is suitable for liquid and gaseous media.

It uses neutral gases or air (control media) to control the flow-rate of water, alcohol, oil, fuel, hydraulic fluid, saline solution, lye, organic solvent and steam (flow media).

### 5.2 Properties

- High leak-tightness.
- High flow values.
- Control air connection can be rotated centrally and steplessly through 360°.
- Optical position indicator
- Maintenance-free

#### 5.2.1 Restrictions

When flow inlet over seat, the angle seat valve must not be used for liquid media due to the risk of water hammer!

## 6 TECHNICAL DATA

### 6.1 Conformity

The angle seat valve, Type 2000 INOX, conforms to the EU Directives according to the EU Declaration of Conformity

### 6.2 Standards

The applied standards, which are used to demonstrate compliance with the EU Directives, are listed in the EU type test certificate and/or the EU Declaration of Conformity.

### 6.3 Operating conditions

#### 6.3.1 Permitted temperatures

Ambient temperature: 0 °C ... +60 °C  
Medium temperature: 0 °C ... +180 °C



The angle seat valve is autoclavable.

For this purpose, the control air connection must be removed.

The combination of maximum medium temperature and maximum ambient temperature is indicated on the graph in ["Fig. 1"](#):

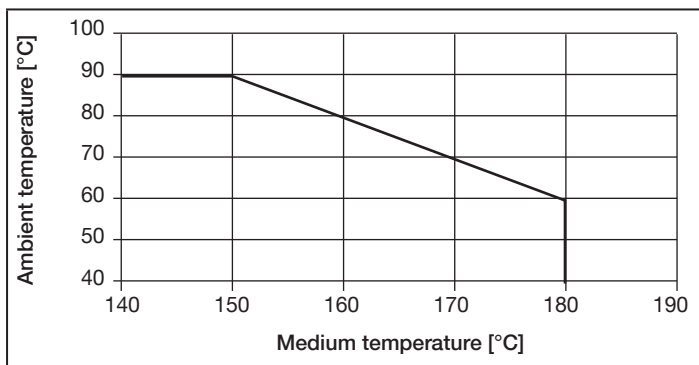

Fig. 1: Combination of medium temperature / ambient temperature

### 6.3.2 Pressure ranges



#### WARNING!

Discharge of medium and danger of bursting.

If the permitted medium or control pressure is exceeded, lines or device may leak and burst.

For control function B a too low control pressure may result in leaks.

- ▶ Do not exceed medium pressure and control pressure.
- ▶ For control function B observe the minimum control pressure of 4 bar.

The product-specific pressure specifications are indicated on the rating plate.

Minimum control pressure for control function B: 4 bar

### 6.3.3 Media



#### WARNING!

**Risk of injury from bursting lines caused by water hammer!**

If the valve is used for liquid media when flow inlet over seat, water hammer may cause lines and device to burst.

- ▶ Do not use valves with flow inlet over seat for liquid media!

Control medium: neutral gases, air

Flow media: water, alcohols, oils, fuels, hydraulic fluids, saline solutions, lyes, organic solvents, steam, air, neutral gases



## 6.4 General technical data

### 6.4.1 Inscription on the rating plate

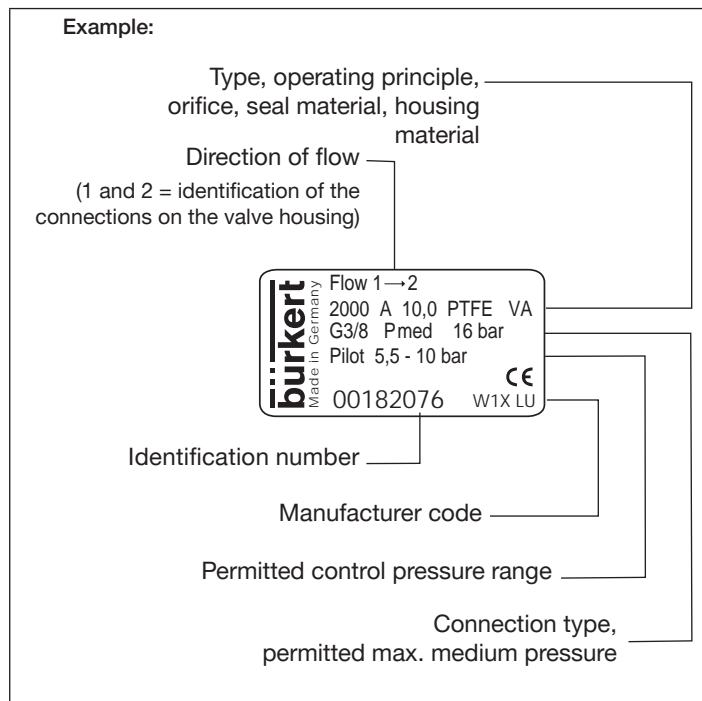

Fig. 2: Example of rating plate

### 6.4.2 Materials

Valve housing	stainless steel 316L
Actuator	stainless steel 1.4404
Sealing elements	FKM
Spindle sealing (with silicone grease)	PTFE-V rings with spring compensation
Seat seal	PTFE
Spindle	stainless steel 1.4401/1.4404

### 6.4.3 Connections

Control air connection (recommendation)	45° hose plug-in connection 4/2 M5 order no. 903383
Medium connection	G3/8 and NPT3/8 socket connection G1/2 external thread Welded spigots according to EN ISO 1127/ISO 4200, DIN 11850 Series 2, ASME BPE. Other connections on request

### 6.4.4 Installation position

Any position, preferably with the actuator face up.

## 7 STRUCTURE AND FUNCTION

### 7.1 Structure

The angle seat valve consists of a pneumatically actuated piston actuator with optical position indicator and a 2/2-way valve housing.

### 7.2 Function

Depending on the version, the valve is closed against the medium flow by spring force (control function A, CFA) or by control pressure (control function B, CFB).

Spring force (CFA) or pneumatic control pressure (CFB) generates the closing force on the pendulum disc. The force is transferred via a spindle which is connected to the actuator piston.

#### Flow inlet under seat:

As the medium pressure is under the pendulum disc, this pressure contributes to the opening of the valve. The flow inlet is under the valve seat.

 If the minimum control pressure is too low for CFB or the permitted medium pressure is exceeded, leaks may occur!

#### 7.2.1 Control functions

##### Control function A (CFA)

Closed in rest position by spring force.

##### Control function B (CFB)

Open in rest position by spring force.

## 8 ASSEMBLY

### 8.1 Safety instructions



#### **DANGER!**

**Risk of injury from high pressure in the system!**

- ▶ Turn off the pressure and vent the lines before loosening lines or valves.



#### **WARNING!**

**Risk of injury from improper assembly!**

- ▶ Installation must only be carried out by authorized technicians and with the appropriate tools!

**Risk of injury from unintentional activation of the system and uncontrolled restart!**

- ▶ Secure system from unintentional activation.
- ▶ Following assembly, ensure a controlled restart.

**Risk of crushing from moving pneumatic connection!**

- ▶ When opening and closing the device, do not touch the moving pneumatic connection.
- ▶ Do not reach into the area immediately above and below the control air connection.

## 8.2 Before installation

- The angle seat valve can be installed in any position, preferably with the actuator face up.
- Before connecting the valve, ensure the pipelines are flush (stress-free).
- Observe direction of flow!  
See "Fig. 3".

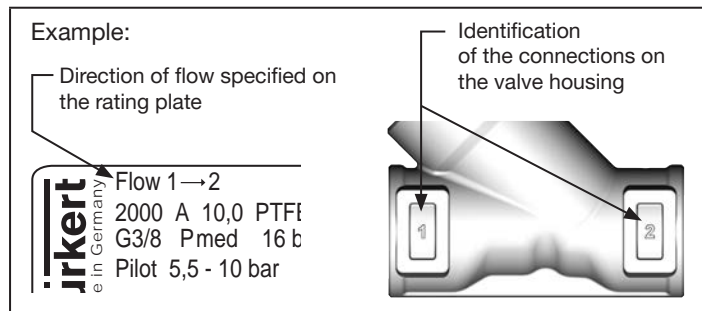

Fig. 3: Identification of the connections / direction of flow

### 8.2.1 Preparatory tasks

→ Clean pipelines (sealing material, swarf, etc.).

#### Welded housing:

→ Before welding in the valve housing, remove the actuator (see Chapter "8.3.1").

## 8.3 Installation

### 8.3.1 Remove actuator from the valve housing (for welded housings only)



#### WARNING!

Risk of injury from damaged devices!

If the wrong tools are used for assembly work, the device may be damaged.

- ▶ To remove the actuator from the valve housing, use an open-end wrench, never a pipe wrench.

#### Control function A:

→ Pressurize control air connection with compressed air (5.5 bar) so that the pendulum disc is lifted off the valve seat and is not damaged.

#### Control function B:

For control function B it is not necessary to apply compressed air for installation.

#### NOTE!

Damage to the seat seal or the seat contour!

- ▶ When removing the actuator, ensure that the valve is in the open position.

→ When valve is in open position, remove actuator from the valve housing using an open-end wrench (see "Fig. 4").

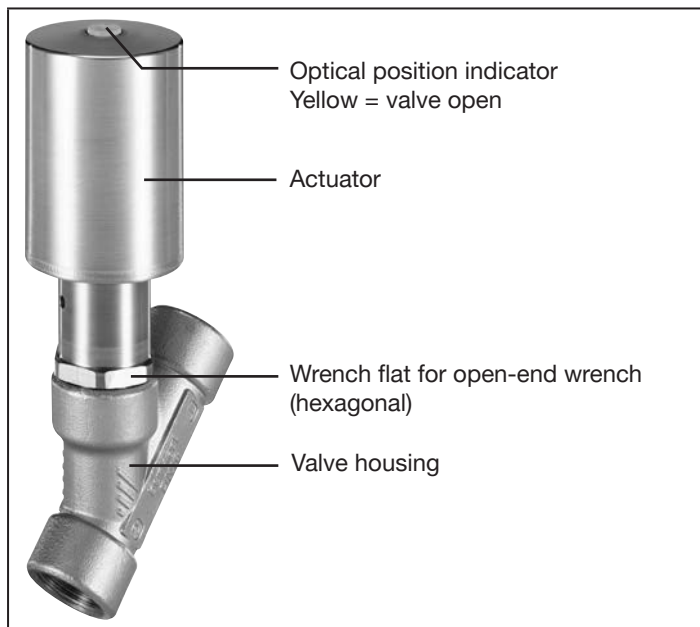

Fig. 4: Removing the actuator

### 8.3.2 Installing valve housing in pipeline

For welded housings:

- Weld valve housing in pipeline system.
- Check graphite seal and, if required, replace.

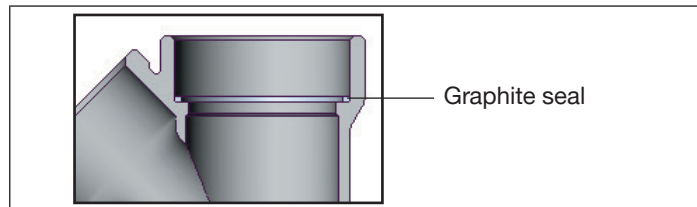

Fig. 5: Graphite seal

For other housing models:

- Connect valve housing to pipeline.

### 8.3.3 Installing actuator on valve housing



#### **DANGER!**

**Risk of explosion if incorrect lubricants used!**

Unsuitable lubricant may contaminate the medium. In oxygen applications there is a risk of explosion.

- ▶ In specific applications, e.g. oxygen or analysis applications, use appropriately authorized lubricants only.

**! WARNING!**

**Risk of injury from damaged devices!**

If the wrong tools are used for assembly work, the device may be damaged. Also if tightening torque is incorrect.

- ▶ To remove the actuator from the valve housing, use an open-end wrench, never a pipe wrench.
- ▶ Observe tightening torque ( $40 \pm 3$  Nm)

- Grease pipe thread before re-installing the actuator (e.g. with Klüber paste UH1 96-402 from Klüber).
  - **For control function A:** Pressurize control air connection with compressed air (5.5 bar) so that the pendulum disc is lifted off the valve seat and is not damaged when screwed in.
  - Screw actuator into the valve housing.
- ! Observe tightening torque ( $40 \pm 3$  Nm)!**

**!** If the position of the control air connection for installation of the hose is unfavorable, it can be aligned steplessly by rotating the actuator through  $360^\circ$ .

## 8.4 Pneumatic connection

**! DANGER!**

**Risk of injury from high pressure in the system!**

- ▶ Before disconnecting lines and valves, turn off the pressure and vent the lines.



**! WARNING!**

**Risk of injury from unsuitable connection hoses!**

Hoses which cannot withstand the pressure and temperature range may result in hazardous situations.

- ▶ Use only hoses which are authorized for the indicated pressure and temperature range.
- ▶ Observe the data sheet specifications from the hose manufacturers.

### 8.4.1 Control air connections

 <p>Order no. 903383</p>	<p>The <math>45^\circ</math> angle connection, which can be ordered separately, is recommended for the control air connection!</p> <p>In this case the free-moving hose length should be min. 250 mm.</p> <p>If the hose length is shorter, the durability and function of the plug-in coupling will be impaired!</p>
	<p>If a straight control air connection is used, the free-moving hose length should be min. 400 mm.</p> <p>If the hose length is shorter, the durability and function of the plug-in coupling will be impaired!</p>
	<p><b>! Risk of crushing!</b></p> <ul style="list-style-type: none"> <li>▶ Due to the risk of crushing, a <math>90^\circ</math> control air connection must not be used!</li> </ul>

## 9 START-UP

### 9.1 Safety instructions



#### **WARNING!**

##### **Risk of injury from improper operation!**

Improper operation may result in injuries as well as damage to the device and the area around it.

- ▶ Before start-up, ensure that the operating personnel are familiar with and completely understand the contents of the operating instructions.
- ▶ Observe the safety instructions and intended use.
- ▶ Only adequately trained personnel may start up the equipment/the device.

## 10 MAINTENANCE, CLEANING

### 10.1 Safety instructions



#### **DANGER!**

##### **Risk of injury from high pressure in the system!**

- ▶ Turn off the pressure and vent the lines before loosening lines or valves.



#### **WARNING!**

##### **Risk of injury from improper maintenance!**

- ▶ Maintenance may only be carried out by authorized technicians and with the appropriate tools!

##### **Risk of injury from unintentional activation of the system and uncontrolled restart!**

- ▶ Secure system from unintentional activation.
- ▶ Following maintenance, ensure a controlled restart.
- ▶ To screw in or unscrew the valve housing or actuator, use an open-end wrench, never a pipe wrench, and observe tightening torques.

### 10.2 Maintenance work

#### 10.2.1 Actuator

The actuator of the angle seat valve is maintenance-free.

## 10.2.2 Angle seat valve

Parts which are subject to natural wear:

- Pendulum disc
- Graphite seal

If leaks occur, replace the particular wearing part with an appropriate spare part (see Chapter "[13 Spare parts](#)").

## 10.3 Cleaning

Commercially available cleaning agents can be used to clean the surface of the device.

### NOTE!

**Avoid causing damage with cleaning agents.**

- ▶ Before cleaning, check that the cleaning agents are compatible with the housing materials and seals.

## 10.4 Recommended auxiliary materials

In this manual the following auxiliary materials are recommended for faultless operation, maintenance and repair of the device:

Type of auxiliary material	Product designation	Manufacturer and Internet address
Lubrication paste	Klüber paste UH1 96-402	Klüber Lubrication München KG, <a href="http://www.klueber.de">www.klueber.de</a>
Adhesive	Loctite 640	Marketing Loctite, Henkel AG & Co.KG&A, <a href="http://www.loctite.de">www.loctite.de</a>

## 11 REPAIRS



### CAUTION!

**Risk of injury and/or damage by the use of incorrect parts!**

Incorrect accessories and unsuitable spare parts may cause injuries and damage the device and the surrounding area.

- ▶ Use original accessories and original spare parts from Bürkert only.

### 11.1 Replacing the valve set

The valve set consists of:

- **The pendulum disc:**  
consisting of
  - Seal holder
  - Seat seal
  - Centering
- **The graphite seal**  
This can also be ordered separately



Before the valve set can be replaced, the actuator must be removed from the valve housing as described below.

### 11.1.1 Removing the actuator from the valve housing

#### **! DANGER!**

**Risk of injury from discharge of medium and release of pressure!**

It is dangerous to remove the device under pressure due to the sudden release of pressure or discharge of medium.

- ▶ Turn off the pressure and vent the lines before loosening lines or valves.

#### **! WARNING!**

**Risk of injury from damaged devices!**

An incorrect tool and an excessive tightening torque may damage the device during installation.

- ▶ To remove the actuator from the valve housing, use an open-end wrench, never a pipe wrench.
- ▶ Observe tightening torque ( $40 \pm 3$  Nm)

#### Control function A:

- Pressurize control air connection with compressed air (5.5 bar) so that the pendulum disc is lifted off the valve seat and is not damaged.

#### Control function B:

- For control function B it is not necessary to apply compressed air for removal.

#### NOTE!

**Damage to the seat seal or the seat contour!**

- ▶ When removing the actuator, ensure that the valve is in the open position.

- When valve is in open position, remove actuator from the valve housing using an open-end wrench (WAF 22) (see "Fig. 6").

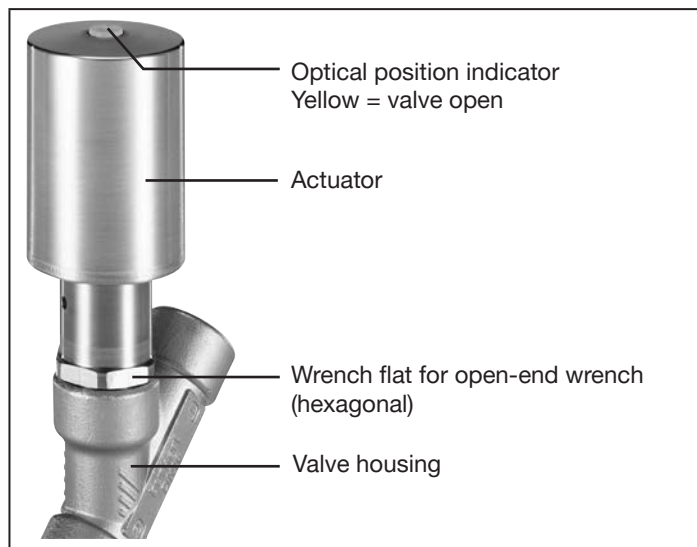

Fig. 6: Removing the actuator



### 11.1.2 Replacing valve set

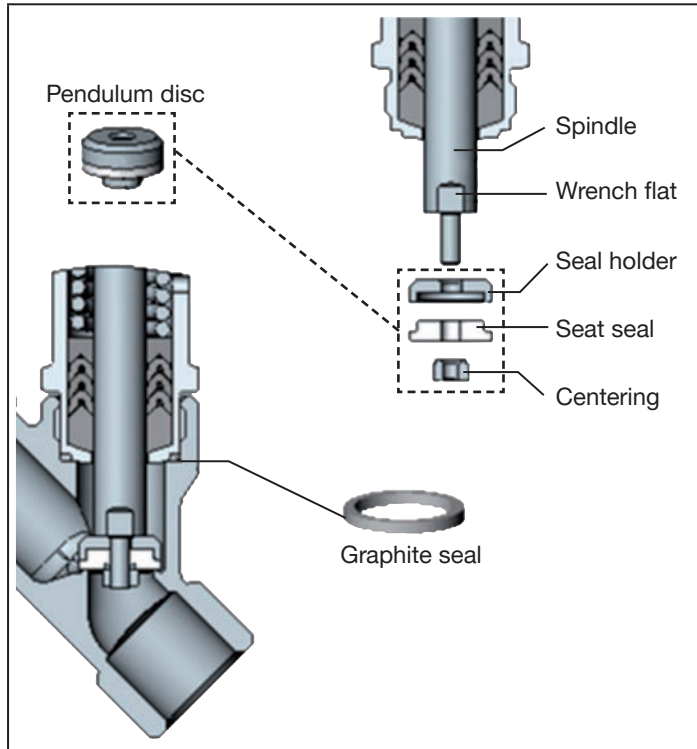

Fig. 7: Valve set



#### WARNING!

##### Risk of injury from damaged devices!

If the wrong tools are used for assembly work, the device may be damaged.

- ▶ To remove the actuator from the valve housing, use an open-end wrench, never a pipe wrench.

If the tightening torque is too great, the spindle thread may be damaged.

#### Procedure:

- Counter spindle on the wrench flat using open-end wrench (WAF 7).
- Carefully loosen centering using a suitable open-end wrench (WAF 5.5) to prevent damaging the spindle thread.
- Unscrew centering.
- Remove seal holder together with seat seal.
- Attach new seal holder and new seat seal to the spindle.
- Apply adhesive (Loctite 640) to spindle thread.
- Screw on centering and tighten using a suitable open-end wrench (WAF 5.5).



Observe tightening torque (0,6 Nm)!

→

### 11.1.3 Installing actuator on valve housing

**WARNING!**

Risk of injury from unintentional activation of the system and uncontrolled restart!

- ▶ Secure system from unintentional activation.
- ▶ Following assembly, ensure a controlled restart.

**DANGER!**

Risk of explosion if incorrect lubricants used!

Unsuitable lubricant may contaminate the medium. In oxygen applications there is a risk of explosion.

- ▶ In specific applications, e.g. oxygen or analysis applications, use appropriately authorized lubricants only.

- Grease pipe thread before re-installing the actuator (e.g. with Klüber paste UH1 96-402 from Klüber).
- Check graphite seal and, if required, replace.

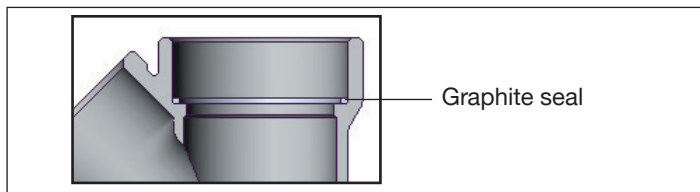

Fig. 8: Graphite seal

- For control function A: Pressurize control air connection with compressed air (5.5 bar) so that the pendulum disc is lifted off the valve seat and is not damaged when screwed in.

**WARNING!**

Risk of injury from damaged devices!

If the wrong tools are used for assembly work, the device may be damaged.

- ▶ To remove the actuator from the valve housing, use an open-end wrench, never a pipe wrench.

If the tightening torque is too great, the spindle thread may be damaged.

- ▶ Observe tightening torque ( $40 \pm 3$  Nm)

- Screw actuator into the valve housing.
- ⚠ Observe tightening torque ( $40 \pm 3$  Nm)!



If the position of the control air connection for installation of the hose is unfavorable, it can be aligned steplessly by rotating the actuator through 360°.

## 12 MALFUNCTIONS

Malfunction	Remedial action
Actuator does not switch.	Control pressure too low. → See pressure specifications on the rating plate.
	Medium pressure too high. → See pressure specifications on the rating plate.
	Direction of flow reversed. → See identification on the rating plate.
Valve is not sealed.	Dirt between seal and valve seat. → Install dirt trap.
	Seat seal worn. → Install new pendulum disc.
	Seat seal damaged, e.g. by foreign objects, swarf or similar. → Install new pendulum disc.
	Direction of flow reversed. → See identification on the rating plate.
	Control pressure too low. → See pressure specifications on the rating plate.
	Medium pressure too high. → See pressure specifications on the rating plate.

Malfunction	Remedial action
Valve is leaking on the release bore.	Spindle seal worn. → Replacing actuator.

Tab. 1: Malfunctions

## 13 SPARE PARTS



### CAUTION!

**Risk of injury and/or damage by the use of incorrect parts!**

Incorrect accessories and unsuitable spare parts may cause injuries and damage the device and the surrounding area.

- ▶ Use original accessories and original spare parts from Bürkert only.

The valve set, order no. 220053, is available as a spare part for the angle seat valve, Type 2000 INOX. This consists of:

- **The pendulum disc:**  
consisting of
  - Seal holder
  - Seat seal
  - Centering
- **The graphite seal**  
This can also be ordered separately

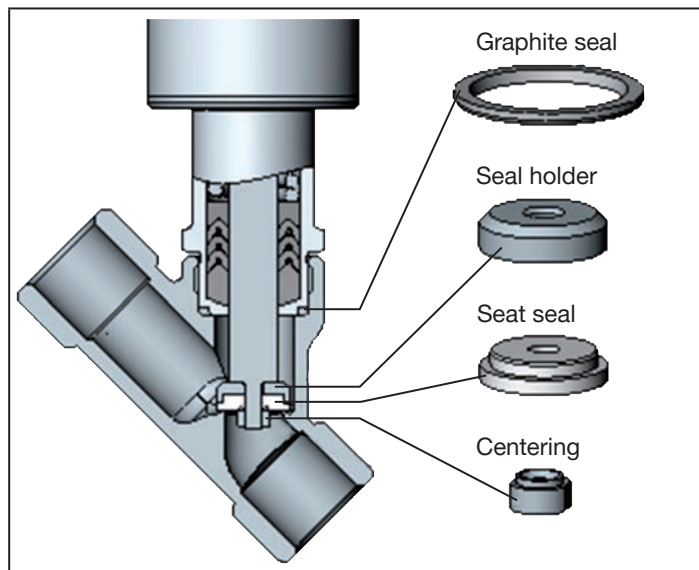

Fig. 9: Valve set

## 14 TRANSPORTATION, STORAGE, DISPOSAL

### NOTE!

#### **Transport damage!**

Inadequately protected devices may be damaged during transportation.

- Protect the device against moisture and dirt in shock-resistant packaging during transportation.
- Prevent the temperature from exceeding or dropping below the permitted storage temperature.

#### **Incorrect storage may damage the device.**

- Store the device in a dry and dust-free location!
- Storage temperature: -20 °C ... +65 °C.

#### **Damage to the environment caused by device components contaminated with media.**

- Dispose of the device and packaging in an environmentally friendly manner!
- Observe applicable disposal and environmental regulations.

[www.burkert.com](http://www.burkert.com)