

## Type S030

INLINE fitting

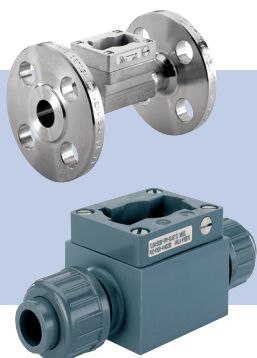

We reserve the right to make technical changes without notice.  
Technische Änderungen vorbehalten.  
Sous réserve de modifications techniques.

### Operating Instructions

Bedienungsanleitung  
Manuel d'utilisation

[www.burkert.com](http://www.burkert.com)

© Bürkert SAS 2010-2018  
Operating Instructions 1811/04\_EU-ML 00563875 ORIGINAL\_FR

MAN 1000305334 EN Version: D Status: RL (released | freigegeben) printed: 20.11.2018

1. ABOUT THE OPERATING INSTRUCTIONS.....	3
2. INTENDED USE.....	5
3. BASIC SAFETY INFORMATION .....	6
4. GENERAL INFORMATION .....	9
5. OPERATING PRINCIPLE.....	9
6. TECHNICAL DATA.....	10
7. INSTALLATION.....	21
8. MAINTENANCE.....	31
9. SPARE PARTS AND ACCESSORIES .....	33
10. PACKAGING, TRANSPORT .....	40
11. STORAGE .....	41
12. DISPOSAL.....	42

## 1. ABOUT THE OPERATING INSTRUCTIONS

The Operating Instructions describe the entire life cycle of the product. Please keep the Operating Instructions in a safe place, accessible to all users and any new owners.

**The Operating Instructions contain important safety information.**

Failure to comply with these instructions can lead to hazardous situations. Pay attention in particular to the chapters [3. Basic safety information](#) and [2. Intended use](#).

- ▶ The Operating Instructions must be read and understood.

### Symbols used



#### DANGER

Warns against an imminent danger.

- ▶ Failure to observe this warning can result in death or in serious injury.



#### WARNING

Warns against a potentially dangerous situation.

- ▶ Failure to observe this warning can result in serious injury or even death.

**CAUTION****Warns against a possible risk.**

- ▶ Failure to observe this warning can result in substantial or minor injuries.

**NOTICE****Warns against material damage.**

Indicates additional information, advice or important recommendations.



Refers to information contained in these Operating Instructions or in other documents.

- ▶ Indicates an instruction to be carried out to avoid a danger, a warning or a possible risk.
- Indicates a procedure to be carried out.

**Definition of the term product**

The term "product" used in these Operating Instructions always refers to the fitting type S030.

4

English

**3. BASIC SAFETY INFORMATION**

This safety information does not take into account any contingencies or occurrences that may arise during installation, use and maintenance of the product.

The local safety regulations for which the operating company is responsible including the staff in charge of installation and maintenance.

**Risk of injury due to high pressure in the installation.**

- ▶ Before any intervention on the installation, stop the circulation of fluid, cut off the pressure and drain the pipe.
- ▶ Observe the fluid temperature-pressure dependency depending of the product used.

**Risk of burn injury due to high fluid temperatures.**

- ▶ Do not touch with bare hands the parts of the product that are in contact with the fluid.
- ▶ Before opening the pipe, stop the circulation of fluid and drain the pipe.

**Risk of injury due to the nature of the fluid.**

- ▶ Respect the prevailing regulations on accident prevention and safety relating to the use of dangerous fluids.

6

English

**2. INTENDED USE****Use of the product that does not comply with the instructions could present risks to people, nearby installations and the environment.**

The fitting type S030 is intended to measure the flow rate of clean fluids in pipes. The fitting type S030 can be combined with a flow transmitter or a flow indicator, fitted with a bajonett connection.

- ▶ Use the product in compliance with the characteristics and commissioning and use conditions specified in the contractual documents, in the Operating Instructions of the product and in the Operating Instructions of the combined instrument.
- ▶ Use the product only in combination foreign devices or foreign components recommended or approved by Bürkert.
- ▶ Store, transport, install and operate the product properly.
- ▶ Only operate a product in perfect working order.
- ▶ Only use the product as intended.

English

5

**Various dangerous situations**

- ▶ Do not use the fittings in PVC or PP in explosive atmospheres.
- ▶ Do not use the product in an environment incompatible with the materials it is made of.
- ▶ Do not subject the product to mechanical loads.
- ▶ Do not make any modifications to the product.
- ▶ Prevent any unintentional power supply switch-on.
- ▶ Only qualified and skilled staff can carry out the installation and maintenance work.
- ▶ Guarantee a defined or controlled restarting of the process, after a power supply interruption.
- ▶ Observe the general technical rules.

English

7

**NOTICE**

**The product may be damaged by the fluid in contact with.**

- ▶ Systematically check the chemical compatibility of the component materials of the product and the fluids likely to come into contact with them (for example: alcohols, strong or concentrated acids, aldehydes, alkaline compounds, esters, aliphatic compounds, ketones, halogenated aromatics or hydrocarbons, oxidants and chlorinated agents).

**4. GENERAL INFORMATION**

To contact the manufacturer of the product use following address:

Bürkert SAS  
 Rue du Giessen  
 BP 21  
 F-67220 TRIEMBACH-AU-VAL

The addresses of our international branches can be found on the Internet at: [www.burkert.com](http://www.burkert.com)

**Warranty conditions**

The condition governing the legal warranty is the conforming use of the product in observance of the operating conditions specified in the Operating Instructions.

**Information on the Internet**

You can find the Operating Instructions and technical data sheet regarding the type S030 at [www.burkert.com](http://www.burkert.com)

**5. OPERATING PRINCIPLE**

The fluid flowing in the piping makes the paddle-wheel turn. The paddle-wheel rotational frequency  $f$  is proportional to the flow rate.

**6. TECHNICAL DATA**

**Conditions of use**



The fluid temperature and the fluid pressure may be restricted by the associated transmitter or indicator: refer to the related Operating Instructions.

Ambient temperature (operating)	depends on the combined transmitter or indicator. Refer to the related Operating Instructions.
Pressure class	PN16 (or PN40 on request) for metal fittings. PN10 for plastic fittings, depends on fluid temperature, see Fig. 1.
Fluid temperature	depends on the materials the fitting body and the paddle-wheel are made, see Table 1.

Paddle-wheel material	Fitting body material	Fluid temperature
PP	▪ Stainless steel	+0...+80 °C
	▪ Brass	
	▪ PVDF	
	▪ PP	
	▪ PVC	
	▪ PVC	+0...+50 °C

Paddle-wheel material	Fitting body material	Fluid temperature	
PVDF	▪ Stainless steel	-15...+100 °C	
	▪ Brass		
	▪ PVDF		
	▪ PP		+0...+80 °C
	▪ PVC		+0...+50 °C

Table 1: Fluid temperature depending on the product materials

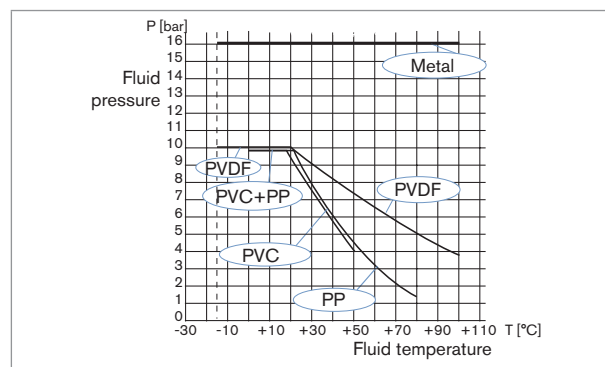

Fig. 1: Fluid pressure-temperature dependency curves for fittings used on their own

## Conformity to standards and directives

The applied standards, which verify conformity with the EU Directives, can be found on the EU Type Examination Certificate and/or the EU Declaration of Conformity (if applicable).

### Conformity to the Pressure Equipment Directive

- Make sure the product materials are compatible with the fluid.
- Make sure the pipe DN and the PN are adapted for the product.

The product conforms to Article 4, Paragraph 1 of the Pressure Equipment Directive 2014/68/EU under the following conditions:

- Product used on a piping (PS = maximum admissible pressure; DN = nominal diameter of the pipe)

Type of fluid	Conditions
Fluid group 1, Article 4 Paragraph 1.c.i	DN ≤ 25
Fluid group 2, Article 4 Paragraph 1.c.i	DN ≤ 32 or PSxDN ≤ 1000
Fluid group 1, Article 4 Paragraph 1.c.ii	DN ≤ 25 or PSxDN ≤ 2000
Fluid group 2, Article 4 Paragraph 1.c.ii	DN ≤ 200 or PS ≤ 10 or PSxDN ≤ 5000

## Fluid data

Maximum fluid viscosity	300 cSt
Type of fluid	Clean, neutral or slightly aggressive liquids
Rate of solid particles in the fluid	max. 1 %
Maximum particle size	0.5 mm

## General data

Flow rate measurement	
▪ Measurement range	▪ 0.3...10 m/s
▪ Measurement deviation	
- with standard K factor	- ±2.5 % of the measured value*
- with K factor determined with a Teach-in procedure	- ±1 % of the measured value* (at the flow rate value the Teach-in has been made)
▪ Linearity	▪ ±0.5 % of the full scale*
▪ Repeatability	▪ ±0.4 % of the measured value*

\* Determined in the following reference conditions:  
medium = water, water and ambient temperatures 20 °C, minimum upstream and downstream distances respected, appropriate pipe dimensions.

## Materials

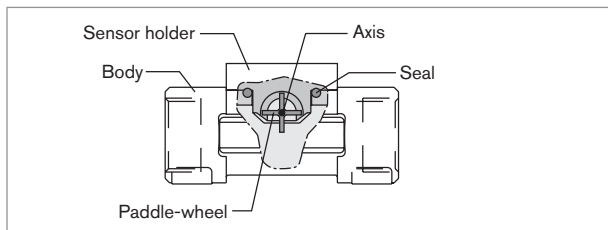

Fig. 2: Sectional drawing of the S030 fitting

Component	Material
Seal	FKM EPDM with FDA agreement on request
Body	Stainless steel (316L - 1.4404) Brass (CuZn39Pb2) PVC, PP, PVDF
Screws	Stainless steel (316L - 1.4404)
Paddle-wheel	PVDF PP on request
Shaft and bearings	Ceramics (Al <sub>2</sub> O <sub>3</sub> )

## Dimensions

- Please refer to the technical data sheets regarding the product type S030, available at: [www.burkert.com](http://www.burkert.com)

## K factors (pulse/litre)

The K factors have all been determined under the following reference conditions: fluid = water, water and room temperatures of 20 °C, minimum upstream and downstream distances respected, appropriate pipe dimensions.



If the S030 fitting is combined with a flow transmitter or a flow indicator that does not automatically convert the K factors, make the conversion using one of the following formulae:

K factor in pulse/US gallon = K factor in pulse/litre x 3.785 to obtain a flow rate value in US gallon/time unit  
K factor in pulse/UK gallon = K factor in pulse/litre x 4.546 to obtain a flow rate value in UK gallon/time unit

**!** Two versions of the S030 in DN15 and DN20 exist, having different K factors.

Only version 2, identified by the "v2" marking, is available from March 2012. The "v2" marking can be found:

- on the bottom of the DN15 or DN20 fitting in plastic:



- on the side of the DN15 or DN20 fitting in metal:

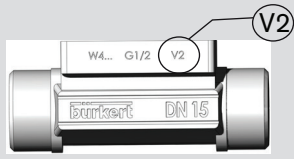

**!** The names of the following norms have changed in the Operating Instructions:

- for the welding ends, norm BS 4825 is renamed BS 4825-1
- for the clamp connections, norm BS 4825 is renamed BS 4825-3
- for the flange connections, norm EN 1092-1 is renamed EN 1092-1 / B1 / PN16

**!**

- The norm ISO for clamp connections is replaced through the norm DIN 32676 series B.
- The norm DIN 32676 series A for clamp connections is added.

Material	Type of connections and standard	K factors (pulse/litre)		
		DN6	DN8	DN15
Stainless steel	Welding ends acc. to:			
	SMS 3008	-	-	-
	DIN 11866 series C / BS 4825-1 / ASME BPE	-	-	-
	DIN 11850 series 2 / DIN 11866 series A / EN 10357 series A	-	278	106
	DIN 11866 series B / ISO 1127 / ISO 4200	-	-	106
	External threads acc. to:			
	SMS 1145	-	-	-
	G	440	278	106
	Internal threads acc. to:			
	G, Rc, NPT	-	-	106
	Clamp acc. to:			
	SMS 3017	-	-	-
	BS 4825-3 / ASME BPE	-	-	-
	DIN 32676 series A	-	278	106
DIN 32676 series B	-	-	106	

K factors (pulse/litre)							
DN15 v2 <sup>1)</sup>	DN20	DN20 v2 <sup>1)</sup>	DN25	DN32	DN40	DN50	DN65
-	-	-	66.9	-	31.1	19.9	11.4
-	106	74.5	66.9	49.0	31.1	19.9	11.4
74.5	106	74.5	66.9	49.0	31.1	19.9	-
74.5	66.5	-	49.0	31.8	19.8	11.4	-
-	-	-	66.9	-	31.1	19.9	-
74.5	66.5	-	49.0	31.8	19.8	11.4	-
-	-	-	66.9	-	31.1	19.9	11.4
-	106	74.5	66.9	-	31.1	19.9	11.4
74.5	106	74.5	66.9	-	31.1	19.9	-
74.5	66.5	-	49.0	31.8	19.8	11.4	-

<sup>1)</sup> See page 16.

Material	Type of connections and standard	K factors (pulse/litre)		
		DN6	DN8	DN15
Stainless steel	Flanges acc. to:			
	EN 1092-1 / B1 / PN16	440		
	ANSI B16-5 JIS 10K		-	106
Brass	All	440	278	106
PVC	All	440	278	116
PP	All	-	-	110
PVDF	All	440	278	118

K factors (pulse/litre)							
DN15 v2 <sup>1)</sup>	DN20	DN20 v2 <sup>1)</sup>	DN25	DN32	DN40	DN50	DN65
74.5	66.5	-	49.0	31.8	19.8	11.4	-
74.5	66.5	-	49.0	31.8	19.8	11.4	-
84.7	75.3	-	52.9	28.5	17.3	10.2	-
89.9	74.2	-	52.9	28.4	17.4	10.1	-
90.3	78.0	-	57.0	31.7	19.0	10.9	-

<sup>1)</sup> See [page 16](#)

## 7. INSTALLATION

### Safety instructions



#### DANGER

**Risk of injury due to high pressure in the installation.**

- ▶ Stop the circulation of fluid, cut-off the pressure and drain the pipe before loosening the process connections.



#### DANGER

**Risk of burn injury due to high fluid temperatures.**

- ▶ Do not touch with bare hands the parts of the product that are in contact with the fluid.
- ▶ Stop the circulation of fluid and drain the pipe before loosening the process connections.

**Risk of injury due to the nature of the fluid.**

- ▶ Respect the prevailing regulations on accident prevention and safety relating to the use of dangerous fluids.



#### WARNING

**Risk of injury due to non-conforming installation.**

- ▶ Fluidic installation can only be carried out by qualified and authorised personnel with the appropriate tools.
- ▶ Observe the installation instructions for the combined transmitter or indicator.

**Risk of injury due to an uncontrolled restart.**

- ▶ Ensure that the restart of the installation is controlled after any interventions on it.



#### WARNING

**Risk of injury if the fluid pressure/ temperature dependency is not respected.**

- ▶ Take into account the fluid pressure/ temperature dependency according to the materials from which the fitting is made and to the measuring device used (see the relevant user manual).
- ▶ Comply with the Pressure Directive 2014/68/EU.

→ Select an appropriate fitting regarding to the flow velocity and the flow rate of the fluid in the piping, see the following charts:

The graph is used to determine the DN of the pipe and the fitting appropriate to the application, according to the fluid velocity and the flow rate.

**Selection example:**

- Specification: if the nominal flow is 10 m<sup>3</sup>/h the dimensioning of the optimal flow rate must be contained in 2 to 3m/s
- Answer: on the chart, the intersection of flow rate and flow velocity gives the appropriate diameter, DN40 or DN50 for fittings with \*.

\* For fittings:

- with external threads according to SMS 1145,
- with welding ends according to SMS 3008, BS 4825-1 / ASME BPE / DIN 11866 series C, DIN 11850 series 2 / DIN 11866 series A / EN 10357 series A
- with clamp connections according to SMS 3017, BS 4825-3 / ASME BPE, DIN 32676 series A

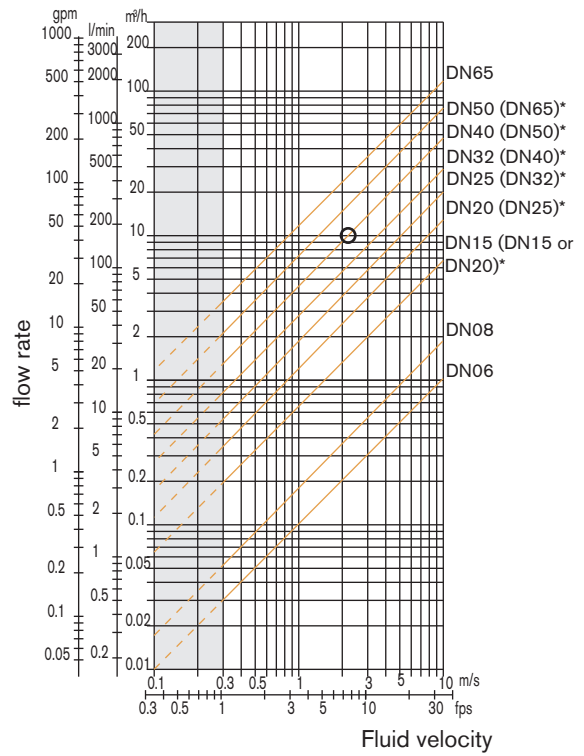

- Install the fitting on the pipe to comply with the upstream and downstream distances defined by standard EN ISO 5167-1 (see Fig. 3).

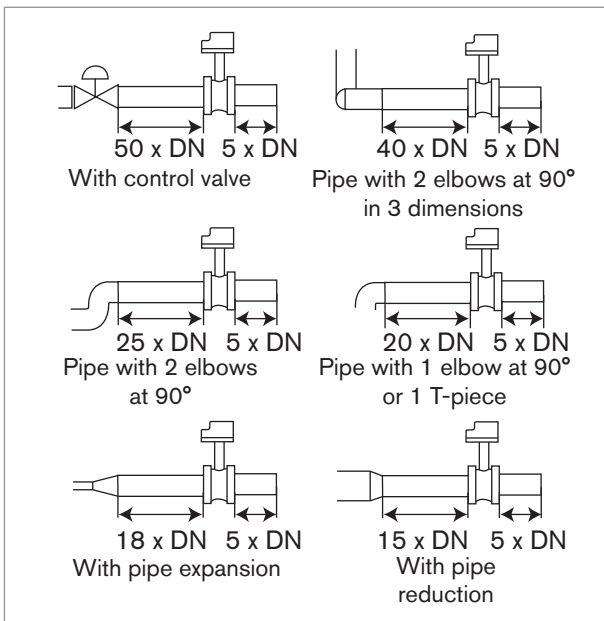

Fig. 3: Upstream and downstream distances depending on the design of the pipes.

- Use a flow conditioner, if necessary, to obtain the best accuracy.
- Prevent the formation of air bubbles in the pipe (see Fig. 4).
- Ensure the pipe is always filled with liquid (see Fig. 5).

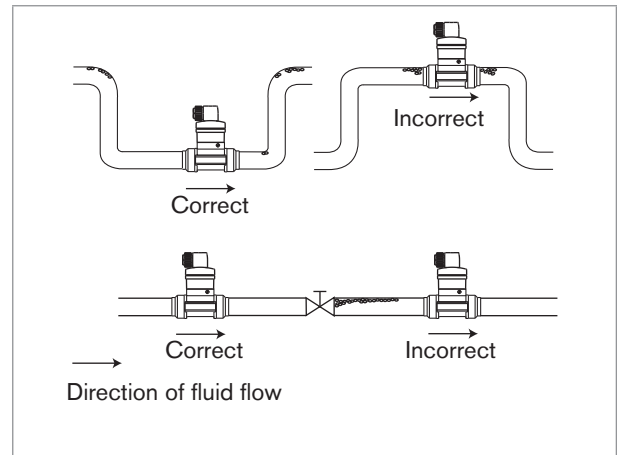

Fig. 4: Additional recommendations on installation

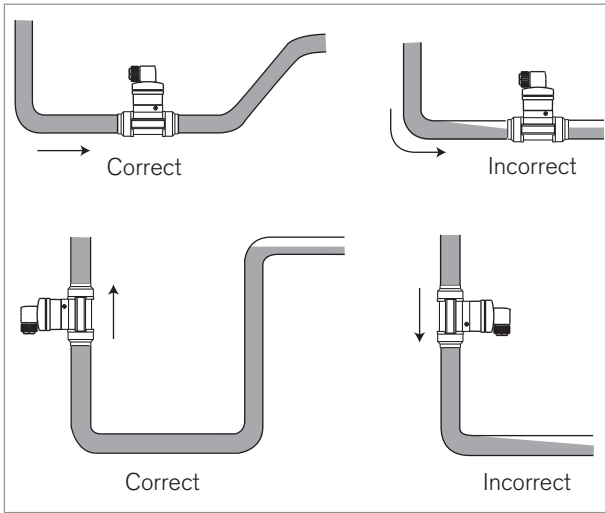

Fig. 5: Additional recommendations on installation

## Installing a fitting with welding ends



Follow the previously described general installation recommendations.

### NOTICE

**The seal on the fitting with welding ends may be damaged during welding.**

- Before welding the weld-ends, unscrew the 4 tightening screws.
- Remove the sensor holder.
- Remove the seal.
- Weld the weld-ends.
- After welding, correctly replace the seal in the groove.
- Replace the sensor holder.
- Tighten the 4 screws in an alternating pattern, applying a nominal tightening torque of 1.5 N·m (1.11 lbf·ft).

## Installing a Clamp fitting



- Make sure the seals are in good condition.
- Place seals adapted to the process (temperature, fluid type) in the grooves of the Clamp fitting.

- Fix the Clamp fitting to the pipe by means of a clamp collar.

## Installing a flange fitting



- Make sure the seals are in good condition.
- Place seals adapted to the process (temperature, fluid type) in the grooves of each connection.



- Make sure the seal remains in the groove while tightening the flange.

- Tighten the flange to fix the fitting to the pipe.

## 8. MAINTENANCE

### Safety instructions



#### DANGER

#### Risk of injury due to high pressure in the installation.

- ▶ Stop the circulation of fluid, cut off the pressure and drain the pipe before loosening the process connections.
- ▶ Observe the fluid temperature/pressure dependency depending on the fitting used.

#### Risk of burn injury due to high fluid temperatures.

- ▶ Do not touch with bare hands the parts of the product that are in contact with the fluid.
- ▶ Stop the circulation of fluid and drain the pipe before loosening the process connections.

#### Risk of injury due to the nature of the fluid.

- ▶ Respect the prevailing regulations on accident prevention and safety relating to the use of dangerous fluids.



**WARNING**

- Risk of injury due to non-conforming maintenance.**
- ▶ Maintenance must only be carried out by qualified and skilled staff with the appropriate tools.
  - ▶ Ensure that the restart of the installation is controlled after any interventions.

**Cleaning**

**NOTICE**

- The product may be damaged by the cleaning solution.**
- ▶ Clean the product with a cloth dampened with water or a detergent compatible with the materials the product is made of.

**9. SPARE PARTS AND ACCESSORIES**

**CAUTION**

- Risk of injury and/or damage caused by the use of unsuitable parts.**
- Incorrect accessories and unsuitable spare parts may cause injuries and damage the product and the surrounding area.
- ▶ Use only original accessories and original spare parts from Bürkert.

Certificate	Article number
Inspection certificate 3.1 acc. to EN 10204	<b>803 723</b>
Test report 2.2 acc. to EN 10204	<b>803 722</b>
Certificate with the surface finish value	<b>804 175</b>
3-point calibration certificate (S030 combined with the instrument mounted)	<b>550 676</b>
FDA approval	<b>803 724</b>

→ For any certificate, contact your Bürkert sales subsidiary.

**!** Two versions of the S030 in DN15 and DN20 exist, having different K factors.

Only version 2, identified by the "v2" marking, is available from March 2012. The "v2" marking can be found:

- on the bottom of the DN15 or DN20 fitting in plastic:



- on the side of the DN15 or DN20 fitting in metal:

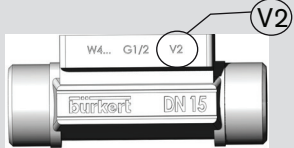

Spare parts	Article number
<b>Sensor holder in stainless steel</b>	
With PVDF paddle-wheel, FKM seal, screws and certificate, for DN06, DN08, DN15 v2 and DN20 v2	<b>448 678</b>
With PVDF paddle-wheel, FKM seal, screws and certificate, for DN15 (except DN15 v2 and DN20 v2) to DN65	<b>432 306</b>
With PVDF paddle-wheel, EPDM seal, screws and certificate, for DN15 (except DN15 v2 and DN20 v2) to DN65	<b>432 305</b>
With PVDF paddle-wheel, EPDM seal, screws and certificate, internal roughness =0,8 µm for DN15 (except DN15 v2 and DN20 v2) to DN65	<b>434 149</b>
With PP paddle-wheel, EPDM seal, screws and certificate, for DN06, DN08, DN15 v2 and DN20 v2	<b>554 896</b>
With PP paddle-wheel, EPDM seal, screws and certificate, for DN15 (except DN15 v2 and DN20 v2) to DN65.	<b>449 425</b>
<b>Sensor holder in brass</b>	
With PVDF paddle-wheel, FKM seal, screws and certificate, for DN06, DN08, DN15 v2 and DN20 v2	<b>448 677</b>

Spare parts	Article number
With PVDF paddle-wheel, FKM seal, screws and certificate, for DN15 (except DN15 v2 and DN20 v2) to DN65	432 304
With PVDF paddle-wheel, EPDM seal, screws and certificate, for DN15 (except DN15 v2 and DN20 v2) to DN65	432 303
With PP paddle-wheel, EPDM seal, screws and certificate, for DN15 (except DN15 v2 and DN20 v2) to DN65.	449 866
<b>Sensor holder in PVC</b>	
With PVDF paddle-wheel, FKM seal, screws and certificate, for DN06, DN08, DN15 v2 and DN20 v2	448 674
With PVDF paddle-wheel, FKM seal, screws and certificate, for DN15 (except DN15 v2 and DN20 v2) to DN65	432 298
With PVDF paddle-wheel, EPDM seal, screws and certificate, for DN15 (except DN15 v2 and DN20 v2) to DN65	432 297
With PP paddle-wheel, EPDM seal, screws and certificate, for DN15 (except DN15 v2 and DN20 v2) to DN65.	443 982
<b>Sensor holder in PP</b>	
With PVDF paddle-wheel, FKM seal, screws and certificate, for DN15 to DN65.	432 300
With PVDF paddle-wheel, EPDM seal, screws and certificate, for DN15 to DN65.	432 299

Spare parts	Article number
With PP paddle-wheel, FKM seal, screws and certificate, for DN15 to DN65.	552 881
With PP paddle-wheel, EPDM seal, screws and certificate, for DN15 to DN65.	443 983
<b>Sensor holder in PVDF</b>	
With PVDF paddle-wheel, FKM seal, screws and certificate, for DN06, DN08, DN15 v2 and DN20 v2	448 676
With PVDF paddle-wheel, FKM seal, screws and certificate, for DN15 (except DN15 v2 and DN20 v2) to DN65	432 302
With PVDF paddle-wheel, EPDM seal, screws and certificate, for DN15 (except DN15 v2 and DN20 v2) to DN65	432 301

**!** Two versions of the S030 in DN15 and DN20 exist, having different K factors.

Only version 2, identified by the "v2" marking, is available from March 2012. The "v2" marking can be found:

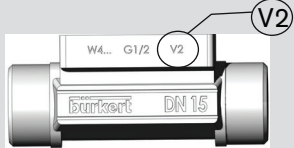
- on the bottom of the DN15 or DN20 fitting in plastic:
 
- on the side of the DN15 or DN20 fitting in metal:
 

Spare parts	Article number
<b>Set of O-rings (DN6 to DN65) for metal fittings</b>	
FKM	426 340
EPDM	426 341
<b>Set of O-rings in FKM for plastic fittings</b>	
DN08	448 679
DN15	431 555
DN20	431 556
DN25	431 557
DN32	431 558
DN40	431 559
DN50	431 560
<b>Set of O-rings in EPDM for plastic fittings</b>	
DN08	448 680
DN15	431 561
DN20	431 562
DN25	431 563
DN32	431 564
DN40	431 565
DN50	431 566

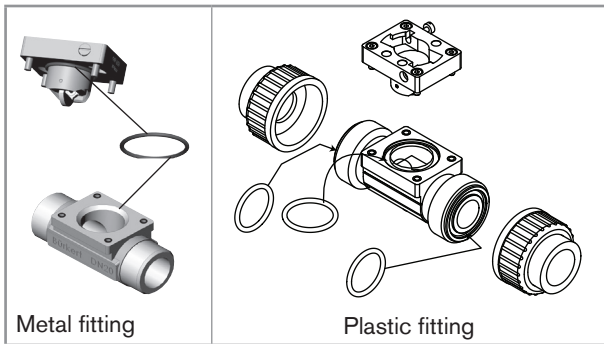

Fig. 6: Position of O-rings in an S030 fitting

## 10. PACKAGING, TRANSPORT

### CAUTION

#### Damage due to transport

Transport may damage an insufficiently protected part.

- ▶ Transport the product in shock-resistant packaging and away from humidity and dirt.
- ▶ Do not expose the product to temperatures that may exceed the admissible storage temperature range.

## 11. STORAGE

### CAUTION

Poor storage can damage the product.

- ▶ Store the product in a dry place away from dust.
- ▶ Storage temperature of the S030 fitting:

Paddle-wheel material	Body fitting material	Storage temperature
PP	▪ Stainless steel	-15...+80 °C
	▪ Brass	
	▪ PVDF	-15...+60 °C
	▪ PVC	
PVDF	▪ Stainless steel	-15...+100 °C
	▪ Brass	
	▪ PVDF	-15...+80 °C
	▪ PVC	

## 12. DISPOSAL

### CAUTION

Damage to the environment caused by parts that are contaminated by fluids.

- ▶ Dispose of the product and its packaging in an environmentally-friendly way.
- ▶ Keep to the existing provisions on the subject of waste disposal and environmental protection.