

Type MKRS

Redundancy block for safety shutdown
Redundanzblock für Sicherheitsabschaltung
Bloc de redondance pour arrêt de sécurité

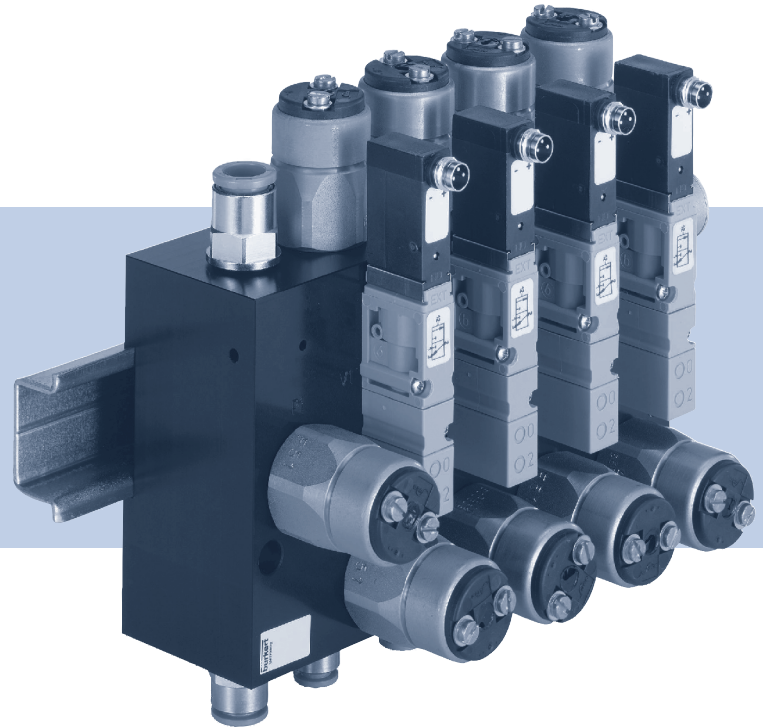

Operating Instructions

Bedienungsanleitung
Manuel d'utilisation

We reserve the right to make technical changes without notice.
Technische Änderungen vorbehalten.
Sous réserve de modifications techniques.

© Bürkert Werke GmbH & Co. KG, 2017

Operating Instructions 1706/008F GJ / Original DE

Redundancy block for safety shutdown

1 THE OPERATING INSTRUCTIONS.....	4	9 MAINTENANCE.....	13
1.1 Definition of the term Device	4	10 DISASSEMBLY.....	13
1.2 Symbols.....	4	11 TRANSPORTATION, STORAGE, DISPOSAL.....	14
2 INTENDED USE.....	5		
3 BASIC SAFETY INSTRUCTIONS.....	5		
4 GENERAL INSTRUCTIONS	6		
4.1 Contact address.....	6		
4.2 Warranty.....	6		
4.3 Information on the Internet	6		
5 SYSTEM DESCRIPTION.....	6		
5.1 Function of Type MKRS.....	7		
6 TECHNICAL DATA.....	8		
6.1 Conformity.....	8		
6.2 Standards.....	8		
6.3 Operating conditions.....	8		
6.4 General technical data.....	8		
7 INSTALLATION.....	10		
7.1 Safety instructions.....	10		
7.2 Attaching the redundancy block.....	10		
7.3 Pneumatic installation.....	11		
7.4 Electrical installation	12		
8 START-UP.....	13		
8.1 Setting switching point	13		

1 THE OPERATING INSTRUCTIONS

The operating instructions describe the entire life cycle of the device. Keep these instructions in an easily accessible location for every user. The instructions must be available to each new owner of the device.

Important information concerning safety!

Carefully read through the operating instructions. In particular, observe the chapters *Basic safety instructions* and *Intended use*.

- ▶ The operating instructions must be read and understood.

1.1 Definition of the term Device

The term "Device" used in these instructions applies to the Type MKRS redundancy block described in these instructions.

1.2 Symbols



DANGER!

Warns of an immediate danger!

- ▶ Failure to observe these instructions will result in death or serious injuries.



WARNING!

Warns of a potentially hazardous situation!

- ▶ Failure to observe these instructions may result in serious injuries or death.



CAUTION!

Warns of a potential danger!

- ▶ Failure to observe these instructions may result in moderate or minor injuries.

NOTE!

Warns of damage!



Important tips and recommendations.



Refers to information in these operating instructions or in other documentation.

- ▶ Marks an instruction to avoid a danger.
- Marks a step which is to be performed.

2 INTENDED USE

Unauthorised use of Type MKRS may be hazardous to persons, systems in the vicinity and the environment.

Type MKRS is designed as a redundancy block for safety valves.

- ▶ To use the device, observe the authorized data, operating instructions and application areas specified in the contract documents and in the operating instructions!
- ▶ The valves must be installed according to the regulations applicable in the country of use.

Do not use the device/product

- ▶ outdoors.
- ▶ Use only in conjunction with third-party devices and components recommended or approved by Bürkert.
- ▶ Operate device/product in perfect condition only and pay attention to correct storage, transportation, installation and operation.
- ▶ Use for intended purpose only.

3 BASIC SAFETY INSTRUCTIONS

These safety instructions do not take into account any unforeseen circumstances and events which occur during installation, operation and maintenance.

The plant operator is responsible for observing the local safety regulations, even with reference to the personnel.



Risk of injury from high pressure in the system/device.

- ▶ Before working on the system or device, switch off the pressure and deaerate/empty the lines.

Risk of injury from uncontrolled process

- ▶ Ensure that the device can be switched off or shut down in an emergency without triggering a hazardous process.
- ▶ After switching off the device, ensure a controlled restart.

Risk of injury from loose hoses.

- ▶ Before pressurising with compressed air, check that the pneumatic hose connections are tight.

General hazardous situations.

To prevent injuries, observe the following:

- ▶ Do not make any internal or external changes to the device and do not mechanically load it.
- ▶ Secure the device from unintentional activation.
- ▶ Only trained technicians may perform installation and maintenance work.
- ▶ Observe the general rules of technology.

4 GENERAL INSTRUCTIONS

4.1 Contact address

Germany

Bürkert Fluid Control Systems
Sales Center
Christian-Bürkert-Str. 13-17
D-74653 Ingelfingen
Tel. + 49 (0) 7940 - 10-91 111
Fax + 49 (0) 7940 - 10-91 448
Email: info@de.buerkert.com

International

The contact addresses can be found on the back pages of the printed operating instructions.

Also on the Internet at: www.burkert.com

4.2 Warranty

A precondition for the warranty is that Type MKRS is used as intended in consideration of the specified operating conditions.

4.3 Information on the Internet

Operating instructions and data sheets for Type MKRS can be found on the Internet at: www.burkert.com

5 SYSTEM DESCRIPTION

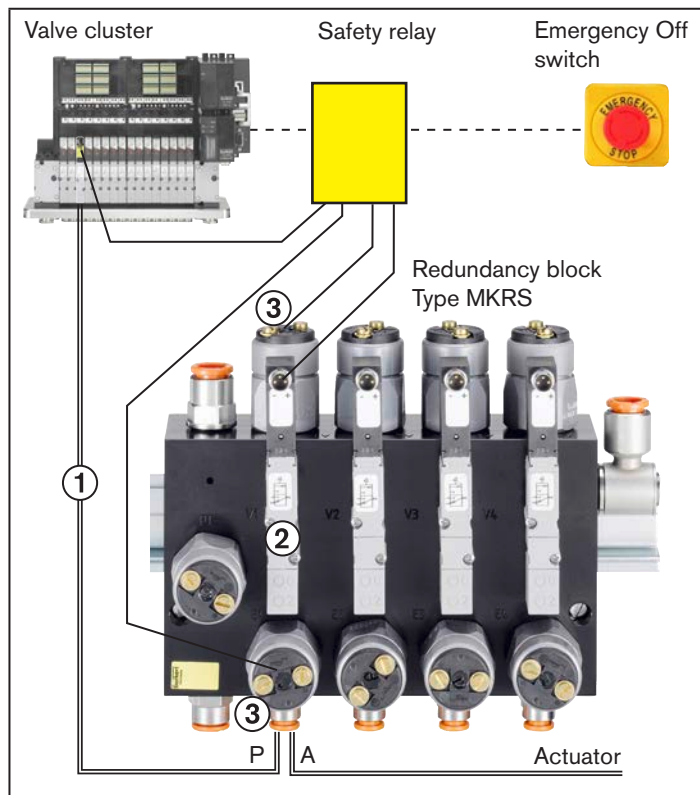

Fig. 1: System set-up

5.1 Function of Type MKRS

The redundancy block has redundancy valves and pressure switches. The pressure switches monitor a set pressure value and open an electric circuit depending on the pressure value.

The redundancy block can use the redundant valve function to reach Performance level D according to the Machinery Directive. To do this, the Performance Level must be determined individually for each system according to Machinery Directive EN ISO 13849.

The Performance Level according to Machinery Directive EN ISO 13849 is an important measure of the reliability of safety-related functions.

Description of "[Fig. 1: System set-up](#)":

The figure shows the set-up with the valve cluster Type 8640. The set-up is identical to Type 8644.

- ① The valve output of the safety valve is connected to the redundancy block Type MKRS.
- ② The redundancy valve functions as a normally closed contact if it is continuously energised.
In the event of a safety shutdown, e.g. by pressing the Emergency Off switch, the redundancy valve is de-energised via a safety relay, i.e. closed.
- ③ Pressure switches monitor the pressure at the input and output of the redundancy valve. This procedure verifies that the safety valve and the redundancy valve have been switched off.



Preset pressure switches:

The pressure switches can be supplied preset. The adjusting screws are thread-locked in this case and the operating pressure is imprinted.

6 TECHNICAL DATA

6.1 Conformity

Type MKRS complies with the EC directives according to the EC Declaration of Conformity.

6.2 Standards

The applied standards, which are used to verify compliance with the directives, can be found in the manufacturer's declaration.

6.3 Operating conditions

Permitted temperatures

Ambient temperature: -10 ... +55 °C (50...131 °F)

Medium temperature: -10 ... +50 °C (50...122 °F)

Media: Compressed air oiled, oil-free, dry neutral gases
(5-µm filter recommended)

Protection class: 3 according to VDE 0580

Installation position: any, preferably horizontally on a top hat rail

6.4 General technical data

Operating principle of valves:

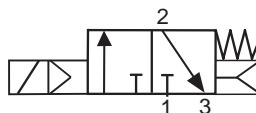

3/2-way valve
in rest position pressure
connection 1 closed,
working connection 2 after
connection 3 open.

6.4.1 Mechanical data

Housing material:

Redundancy block	Aluminium anodized
Valves	PA

Pressure switch:

Housing material	Steel galvanised CrVI-free
Sealing material	NBR,
Function	Normally closed contact, closed in rest position
Adjustment range	
Switching point	1...10 bar (14.5...145 Psi) Tolerance at room temperature ±0.5 bar (±7.25 Psi) Factory setting: 4 bar (58.01 Psi)
Switching times:	Opening 15 ms Closing 20 ms
Switching frequency	< 200/min ⁻¹

6.4.2 Pneumatic data

Control pressure:	2.5...10 bar (36...145 Psi)
Supply connection:	D8
Working connection:	D6

6.4.3 Electrical data

Operating voltage:	
Valves	24 V
Pressure switch	max. 42 V
Power consumption:	per valve 0.8 W
Rated current:	max. 4 A
Electrical connection:	
Valves	Circular plug-in connector M8, 3-pole
Pressure switch	Screw terminals M3

7 INSTALLATION

7.1 Safety instructions



DANGER!

Risk of injury from high pressure in the system/device.

- ▶ Before working on the system or device, switch off the pressure and deaerate/empty the lines.

Risk of injury from electric shock.

- ▶ Before working on the system or device, switch off the power supply and secure to prevent reactivation.
- ▶ Observe the applicable accident prevention and safety regulations for electrical devices.



WARNING!

Risk of injury due to improper installation!

- ▶ Installation may be carried out by trained technicians only and with the appropriate tools!
- ▶ Secure system from unintentional activation.
- ▶ Following installation, ensure a controlled restart.

7.2 Attaching the redundancy block

The top hat rail mounting is provided for Type MKRS.

→ To attach the guide on the back of the device, hook into the top hat rail.

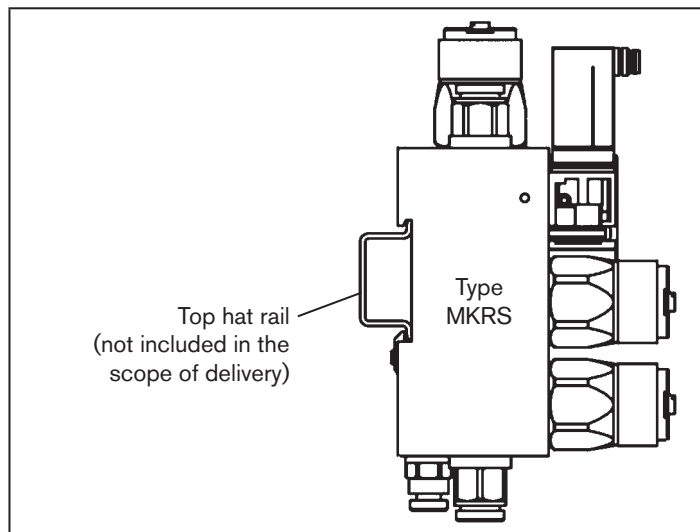

Fig. 2: Attachment to top hat rail

7.3 Pneumatic installation



WARNING!

Risk of injury from loose hoses.

Hoses which are not secure may become detached when compressed air is applied and make whipping movements.

- ▶ Before pressurising with compressed air, check that the pneumatic hose connections are tight.

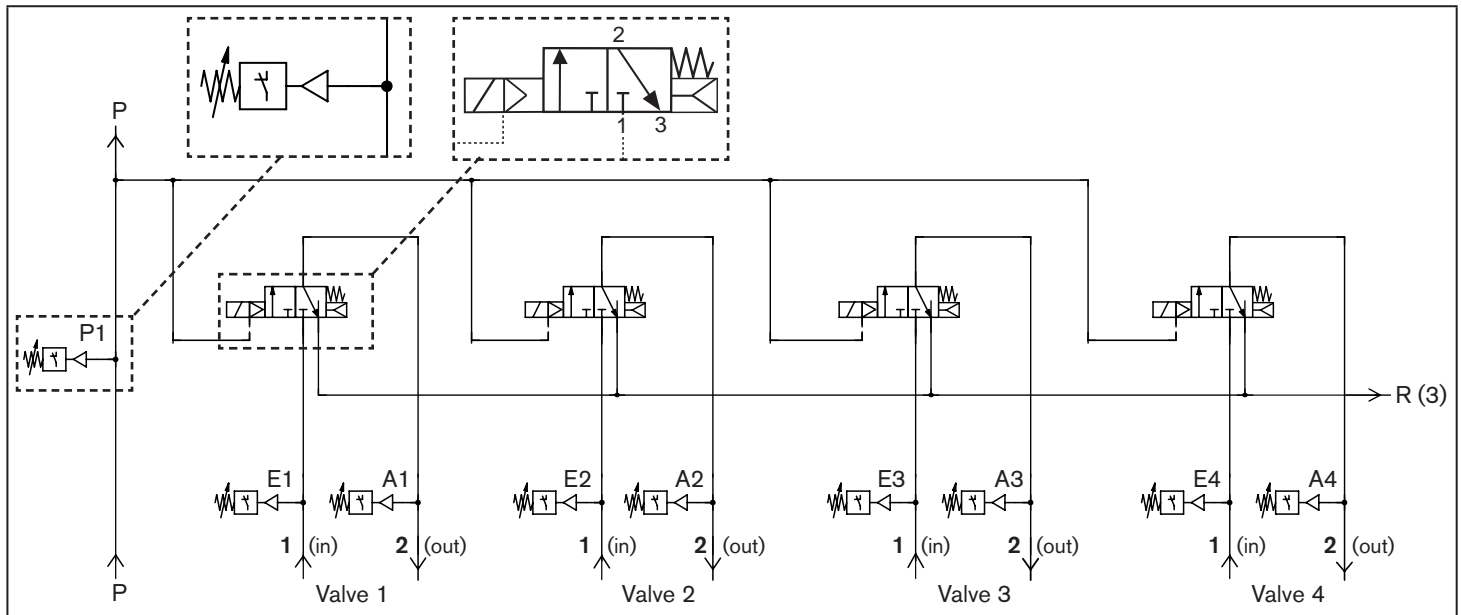

Fig. 3: Pneumatic installation – wiring chart

→ Connect the safety valves to the redundancy block MKRS (see "Fig. 4: Pneumatic installation").

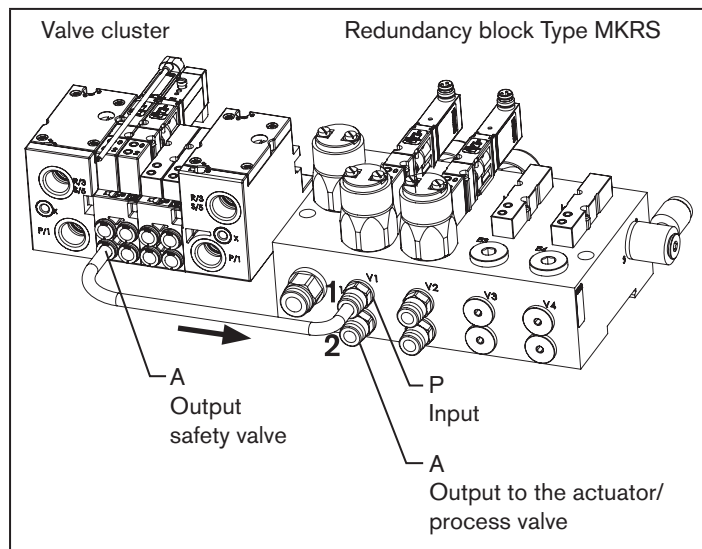

Fig. 4: Pneumatic installation

7.4 Electrical installation

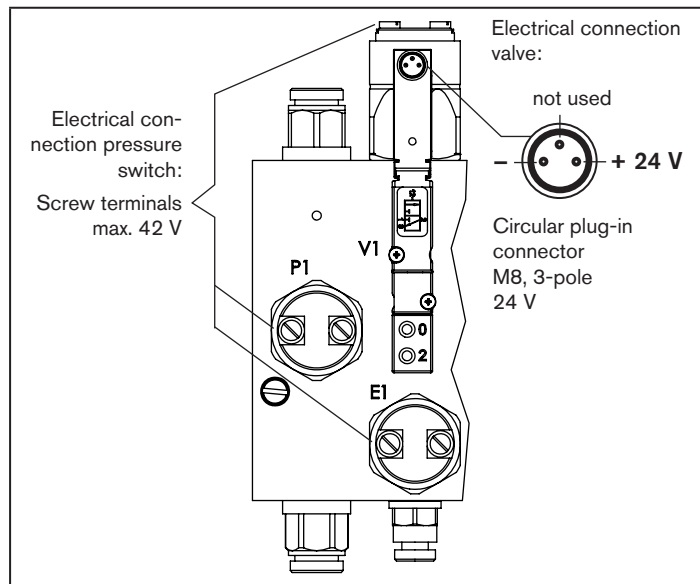

Fig. 5: Electrical installation

7.4.1 Electrical connection valves

→ Connect valves electrically to the circular plug-in connector M8, 3-pole 24 V.

⚠ Note polarity. See "Fig. 5".

7.4.2 Electrical connection pressure switches

→ Connect pressure switches electrically to the screw terminals.
Maximum voltage 42 volts. See "Fig. 5".

8 START-UP

8.1 Setting switching point

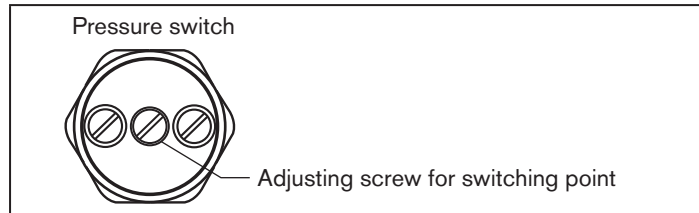

Fig. 6: Setting switching point

Switching point of the pressure switches set at the factory: 4 bar
The switching point can be changed by turning the adjusting screw.

Increasing pressure for switching point:

→ Turn adjusting screw clockwise.

Reducing pressure for switching point:

→ Turn adjusting screw anti-clockwise.



Preset pressure switches:

The pressure switches can be supplied preset. The adjusting screws are thread-locked in this case and the operating pressure is imprinted.

9 MAINTENANCE

If the operating conditions described in these instructions are observed, Type MKRS is maintenance-free.

10 DISASSEMBLY



WARNING!

Risk of injury due to improper removal!

► Disassembly may be carried out by trained technicians only and with the appropriate tools!

1. Disconnect electrical connection.
→ Remove the circular plug-in connectors.
→ Loosen the screw terminals and pull out cables.



DANGER!

Risk of injury from high pressure in the system/device.

► Before working on the system or device, switch off the pressure and deaerate lines.

2. Disconnect pneumatic connections to the valve cluster
→ Loosen hose connections and remove hoses.
3. Remove redundancy block MKRS from top hat rail.

11 TRANSPORTATION, STORAGE, DISPOSAL

NOTE!

Damage in transit!

Inadequately protected devices may be damaged during transport.

- Protect the device from moisture and dirt in shock-resistant packaging during transportation.
- Avoid exceeding or dropping below the permitted storage temperature.

Incorrect storage may damage the device.

- Store device in dry and dust-free conditions!
- Storage temperature: -10...+55 °C.

Damage to the environment caused by parts contaminated with media.

- Dispose of device and packaging in an environmentally friendly manner!
- Observe applicable disposal and environmental regulations.

www.burkert.com