

Type 8746 büS / CANopen

Mass Flow Meter (MFM) / Mass Flow Controller (MFC)
Massendurchflussmesser (MFM) / Massendurchflussregler (MFC)
Débitmètre massique (MFM) / Régulateur de débit massique (MFC)

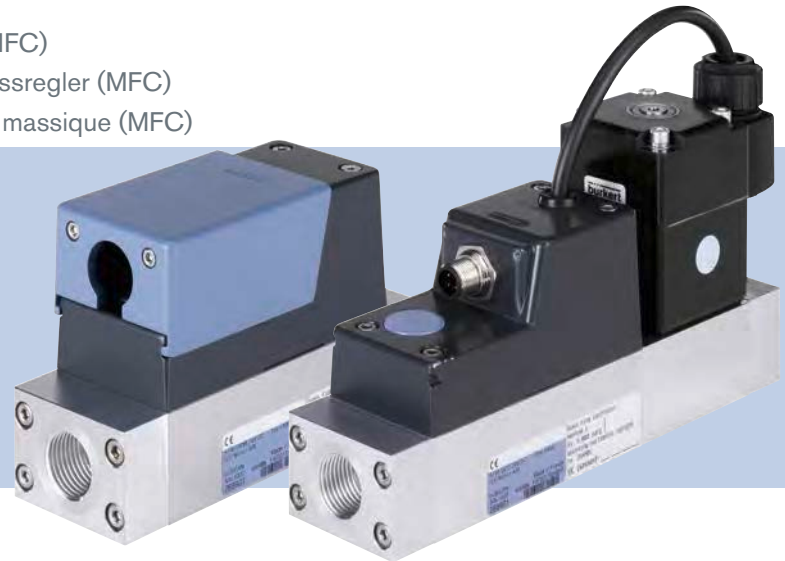

Operating Instructions

Bedienungsanleitung
Manuel d'utilisation

We reserve the right to make technical changes without notice.
Technische Änderungen vorbehalten.
Sous réserve de modifications techniques.

© Bürkert SAS, 2015 - 2017

Operating Instructions 1702/03_EU-ML 00810417 / Original DE

1 OPERATING INSTRUCTIONS	5	6.6 Electrical data.....	16
1.1 Definition of the term device	5	6.7 Markings	17
1.2 Symbols used.....	5	7 INSTALLATION	19
2 INTENDED USE	6	7.1 Safety instructions	19
2.1 Versions with explosion protection	6	7.2 Before installation	20
3 BASIC SAFETY INFORMATION	7	7.3 Mechanical installation	20
4 GENERAL INFORMATION	8	7.4 Fluid system installation	20
4.1 Manufacturer's name, manufacturer's address and international contacts.....	8	7.5 Installation and removal of the impact protection cover and blind plug.....	22
4.2 Warranty	8	7.6 Setting up the fieldbus	22
4.3 Information on the Internet.....	8	7.7 Electrical installation.....	23
5 DESCRIPTION OF THE DEVICE	9	7.8 Connecting the functional earth.....	24
5.1 Design of the MFM.....	9	7.9 Connecting the cable screen.....	24
5.2 Design of the MFC with solenoid valve.....	9	8 COMMISSIONING	25
5.3 Design of the MFC with motor valve	10	8.1 Safety instructions.....	25
5.4 General description.....	11	9 OPERATION AND FUNCTION	25
5.5 Operation of the MFM (Mass Flow Meter)	11	9.1 Safety instructions.....	25
5.6 Operation of the MFC (Mass Flow Controller).....	11	9.2 Normal control mode	25
5.7 Operation of the sensor in the device.....	13	9.3 Device status LED	26
6 TECHNICAL DATA	14	9.4 LED to indicate the motor valve status	27
6.1 Conformity.....	14	9.5 Setting up the fieldbus	27
6.2 Standards	14	9.6 Replaceable configuration memory	27
6.3 Operating conditions	14	9.7 Functions	29
6.4 Mechanical data.....	15		
6.5 Fluid data	15		

10	MAINTENANCE	32
10.1	Maintenance for operation with heavily contaminated media	32
10.2	Cleaning and recalibration at the factory	33
11	DEVICE STATUS/TROUBLESHOOTING	34
11.1	Display of the device status	34
11.2	Troubleshooting for the device	36
11.3	Troubleshooting for the motor valve	38
12	ACCESSORIES /SPARE PARTS	38
12.1	Electrical Accessories	38
12.2	Fluid accessories	39
12.3	Bürkert-Communicator (PC software).....	39
12.4	Additional documentation	40
12.5	Spare parts.....	40
13	DECOMMISSIONING	40
13.1	Safety instructions	40
13.2	Dismantling the device	41
14	TRANSPORT, STORAGE, DISPOSAL	42
15	RETURNING THE DEVICE	42

1 OPERATING INSTRUCTIONS

The Operating Instructions describe the entire life cycle of the device. Please keep them in a safe place, accessible to all users and any new owners.

Important safety information!

Please read the manual carefully. Pay particular attention to the sections [Basic safety information](#) and [Intended use](#).

- ▶ This operating manual must be read and understood.

1.1 Definition of the term device

The term "device" as used within this manual, always refers to the MFM / MFC Type 8746 with büS / CANopen digital communication.

1.2 Symbols used

The following symbols are used in these instructions.



DANGER!

Warns of immediate danger!

- ▶ If ignored, death or serious injury will result.



WARNING!

Warns of a situation which is possibly dangerous!

- ▶ If ignored, serious injury or death may result.



CAUTION!

Warns of possible danger!

- ▶ Failure to observe this warning can result in substantial or minor injuries.

NOTE!

Warns of damage to property!



Important advice and recommendations.



Refers to information in this operating manual, or in other documents.

- ▶ Indicates a risk prevention statement.

→ Indicates a procedure that must be carried out.

2 INTENDED USE

Improper use of the device may be a hazard to people, nearby equipment and the environment.

MFM type 8746 is used exclusively to measure the mass flow of clean dry gases.

MFC type 8746 is used exclusively to control the mass flow of clean dry gases.

- ▶ Observe the additional data, operating and service conditions specified in the contract documents, the Operating Instructions and on the name plate and calibration plate.

The device

- ▶ Use only for the media indicated on the name plate and in the calibration protocol.
- ▶ only use indoors.
- ▶ only use up to an altitude of 2000 m.
- ▶ Use only in conjunction with external instruments and components recommended by Bürkert.
- ▶ Operate carefully and ensure regular, professional maintenance.
- ▶ Operate only in perfect working order and ensure appropriate storage, transport, installation and control.
- ▶ Use only for its intended purpose.

2.1 Versions with explosion protection



DANGER!

Danger of explosion in the event of improper use in potentially explosive areas!

- ▶ Observe the specifications of the conformity certificate.
- ▶ For Ex. certified versions, the specifications in the ATEX supplement for type 8746 available at www.burkert.com must be observed.

2.1.1 Ex. certification

The Ex. certification is only valid if the Bürkert device is used as described in the ATEX supplement for type 8746.

If unauthorized changes are made to the device, the Ex. certification becomes invalid.

3 BASIC SAFETY INFORMATION

These safety instructions do not take the following into account:

- any contingencies or occurrences that may arise during installation, use and maintenance.
- Location-specific safety regulations, adherence to which, also on the part of the mounting personnel, is the responsibility of the operator.



Danger due to high pressure in the installation/device.

- Before working on the installation or device, cut the pressure and vent and drain the pipes.

Risk of injury from electric shocks.

- Before working on the installation or device, switch off the power and ensure that it cannot be reactivated.
- Observe the applicable accident protection and safety regulations for electrical equipment!

Burns/fire hazard due to hot surface of the device!

- Keep the device away from any highly flammable materials or media and avoid any contact with bare hands.

Danger due to escape of the medium.

- Observe the applicable accident protection and safety regulations relating to the operating medium used.

Various dangerous situations.

To avoid personal injury, take care:

- Not to operate the device without the factory installed input filters.
- Only to operate the device in the installation position given on the calibration plate.
- That the operating pressure of the device is not higher than the maximum calibration pressure (MFM) specified on the calibration plate or the tightness pressure of the proportional valve (MFC).
- To only use the device for the medium specified as the operating medium in the calibration protocol.
- Only to use agents that are stable with the device materials for cleaning and decontamination
The compatibility chart can be found on our homepage: www.buerkert.com
In the event of any ambiguity please contact your local sales office.
- Do not make any modifications to the device and do not subject the device to mechanical loads.
- Protect the installation/device from accidental actuation.
- Only trained personnel may perform installation and maintenance work.
- After an interruption in the electrical and media supply, ensure a controlled restart of the process.
- Observe best industry practice.

NOTE!

Components / assemblies at risk from electrostatic charges!

The device contains electronic components which are susceptible to electrostatic discharge (ESD). Contact with electrostatically charged persons or objects endangers these components. In the worst case, they will become defective immediately or will fail when energized.

- To minimise or even avoid all damage due to an electrostatic discharge, take all the precautions described in the EN 61340-5-1.
- Do not touch any of the live electrical components.

4 GENERAL INFORMATION

4.1 Manufacturer's name, manufacturer's address and international contacts

The name of the manufacturer is displayed as inset writing on the cover and the housing of the device.

The manufacturer of the device can be contacted at the following address:

Bürkert SAS
Rue du Giessen
F-67220 TRIEMBACH-AU VAL

The addresses of our international sales offices are available on the internet at: www.burkert.com

4.2 Warranty

The warranty is conditional on compliant use of the device in observance of the operating conditions specified in the Operating Instructions.

4.3 Information on the Internet

Operating Instructions and data sheets for the type 8746 can be found online at: www.burkert.com

Type 8746

description of the device

5 DESCRIPTION OF THE DEVICE

5.1 Design of the MFM

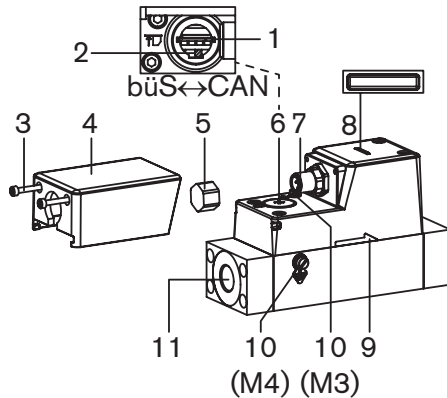

- | |
|---|
| 1. Configuration memory |
| 2. Setting of the fieldbus |
| 3. Mounting screws |
| 4. Impact protection cover (only necessary on ATEX versions) |
| 5. M12 sealing cap (only ATEX versions) |
| 6. Blind plug (access to the configuration memory and fieldbus switch) |
| 7. Connector (counterpart is not part of the device) for electrical connection (5-pin M12 plug) |

- | |
|---|
| 8. LED to display the device status (according to NAMUR NE 107) |
| 9. Flow direction |
| 10. Functional earth connection: M3 / M4 screws for cable shielding and device earthing |
| 11. Fluid connection |

Fig. 1: Design of the MFM

5.2 Design of the MFC with solenoid valve

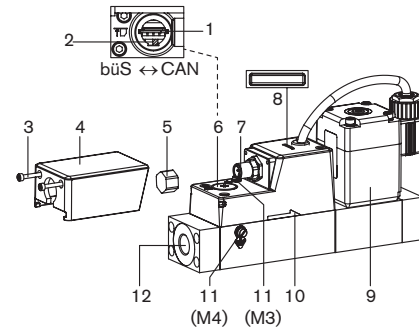

- | |
|--|
| 1. Configuration memory |
| 2. Setting of the fieldbus |
| 3. Mounting screws |
| 4. Impact protection cover (only necessary on ATEX versions) |
| 5. M12 sealing cap (only ATEX versions) |

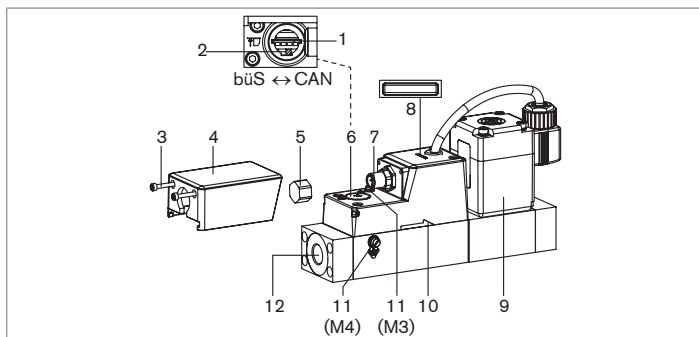

- | |
|---|
| 6. Blind plug (access to the configuration memory and fieldbus switch) |
| 7. Connector (counterpart is not part of the device) for electrical connection (5-pin M12 plug) |
| 8. LED to display the status of the MFC (according to NAMUR NE 107) |
| 9. Solenoid valve (direct acting, normally closed) |
| 10. Flow direction |
| 11. Functional earth connection: M3 / M4 screws for cable shielding and device earthing |
| 12. Fluid connection |

Fig. 2: Design of the MFC with solenoid valve

5.3 Design of the MFC with motor valve

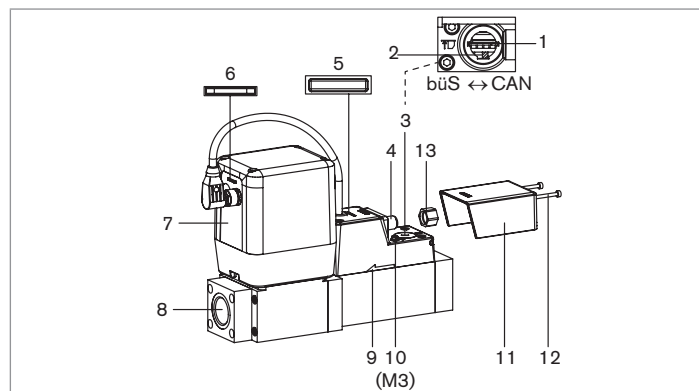

- | |
|---|
| 1. Configuration memory |
| 2. Setting of the fieldbus |
| 3. Blind plug (access to the configuration memory and fieldbus switch) |
| 4. Connector (counterpart is not part of the device) for electrical connection (5-pin M12 plug) |
| 5. LED to display the status of the MFC (according to NAMUR NE 107) |
| 6. LED to display the status of the motor valve |
| 7. Electromotive proportional valve (if deenergized, remains in the current position) |
| 8. Fluid connection |

9. Flow direction
10. Functional earth connection: M3 screw for cable shielding and device earthing (also possible with M4 screw – M4 screw is not represented)
11. Impact protection cover (only necessary on ATEX versions)
12. Mounting screws
13. M12 sealing cap (only ATEX versions)

Fig. 3: Design of the MFC with motor valve

5.4 General description

The device is available in two basic versions.

- As a Mass Flow Meter (MFM) the device measures the mass flow of the gases for which it has been calibrated.
- As a Mass Flow Controller (MFC) the device measures and controls the mass flow of the gases for which it has been calibrated. In contrast to the MFM, the MFC also contains a proportional valve. The gas must be in a dry and clean state.

Digital communication with the device (for example for transfer of the setpoint or measured value) is achieved via CANopen*- or bÜS**.



* CANopen - A fieldbus based on CAN (Controller Area Network) that is used in automation technology for networking of instruments.

** bÜS - A CANopen-based fieldbus with additional functionalities.

5.5 Operation of the MFM (Mass Flow Meter)

A sensor is integrated into the MFM to measure the mass flow. The measured value is transmitted to an external instrument via a digital output (fieldbus).

5.6 Operation of the MFC (Mass Flow Controller)

Design:

- The mass flow is measured by a sensor.
- To control the mass flow, the MFC is fitted with electronics and a proportional valve.

NOTE!

Malfunction due to contamination.

For problem-free functioning of the MFC, a filter must be installed in front of the device for contaminated operating media.

See chap. [6.3.1 Quality of the operating medium.](#)

Operation:

The sensor measures the mass flow and relays the measured value to the integrated electronics. The electronics compares the measured current value (x) with the desired setpoint value (w) and calculates the control value to be transmitted to the proportional valve (Y) in order to control its opening.

The mass flow is either kept stable at a constant value or altered according to a predefined profile.

The regulation is performed independent of pressure fluctuations or increased flow resistance, such as might be caused by dirty filters.

The response time of the proportional valve and the dynamics of the sensor determine the setting time.

The measured mass flow value is transmitted to an external device via a digital output (fieldbus).



In order to obtain a dynamic or quiet measured-value output signal, the damping of this signal can be adjusted by the Bürkert-Communicator software. See chap. [12.3](#).

Function diagram:

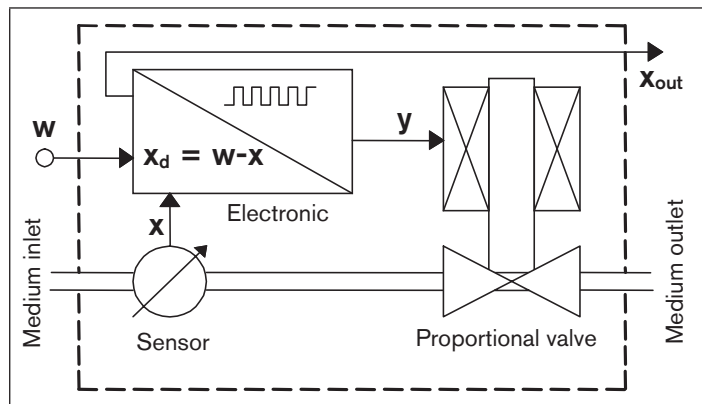

Fig. 4: Function diagram of the MFC (Mass Flow Controller)

5.6.1 The MFC electronics

The electronics

- compare the measured value of the mass flow with the specified setpoint
- and controls the opening of the proportional valve.

Setpoint

The setpoint (w) is transmitted digitally via the fieldbus interface.

For control of a system where quick flow-rate changes are not permitted, a ramp function can be activated. This enables the parameters for an ascending or descending setpoint to be set separately.

Control settings

The control settings are preset at the factory.

Amplification factors:

After start-up, the controller operates with amplification factors dependent on the control-loop properties. The gain factors are calculated automatically when the *AUTOTUNE* function is run. The *AUTOTUNE* function enables the control settings to be optimised for the installation's actual conditions..

Dynamic control parameters:

The dynamics for the control loop of the device is influenced by two settings, the gain (K_P) and reset time (T_N). The dynamic control settings can be adapted using the Bürkert-Communicator software (see chap. [12.3 Bürkert-Communicator \(PC software\)](#))

The extreme settings are:

1. A very quick regulation with the possibility of overshoots. The controller reacts to even the smallest deviations. The control may then cause very strong fluctuations.
2. A slow-acting regulation.
For less dynamic applications, the behaviour of the controller may be damped. It then reacts slowly to very minor fluctuations of the measured value or set-point.

Zero point shut-off (cannot be adjusted):

A zero point shut-off is included to ensure the sealing function of the valve. This is activated if the following conditions occur simultaneously.

1. Setpoint < 2 % of nominal flow rate Q_{nominal} (with measuring range 1:50)
2. Measured value < 2 % of nominal flow rate Q_{nominal} (with measuring range 1:50)



If the zero point shut-off is active, the PWM signal is set to 0 % so that the valve is completely closed.

5.6.2 MFC solenoid valve

MFCs use 2 valve principles. The first is a direct acting, normally-closed proportional valve. The second is an electromotive proportional valve which remains in the latest position, if deenergized.

The nominal diameter of both valves is determined by the required nominal flow-rate Q_{nominal} , the pressure conditions in the process and the density of the operating medium.

5.7 Operation of the sensor in the device

The integrated flow rate sensor in the device use the thermal measurement process (anemometric and calorimetric) to measure the mass flow. This essentially consists of a heating resistor and a temperature probe. The operating medium which flows through the device modifies the temperature difference measured between the two resistors.

The thermal measurement principle allows the MFC to control the required mass flow almost independently of the pressure and temperature fluctuations in the application concerned.

6 TECHNICAL DATA

6.1 Conformity

The device complies with the EU directives according to the EU declaration of conformity (if applicable).



Instructions for use in Ex. areas (see the ATEX instructions in the supplement for types 8742 /8746 at www.burkert.com).

6.2 Standards

The standards used to demonstrate conformity with the Directives can be consulted in the EU type examination certificate and/or the EU declaration of conformity (if applicable).

6.3 Operating conditions



WARNING!

Risk of injury from malfunction due to outdoor use!

- ▶ Do not use the device in outdoor areas.

Special operating conditions with ATEX certification: See the ATEX supplement for the type 8746.

Permissible temperatures

Ambient temperature:	-10 °C...+50 °C
Medium temperature, solenoid valve: for oxygen:	-10 °C...+70 °C -10 °C...+60 °C

Medium temperature, motor valve:	0 °C...+70 °C
for oxygen:	0 °C...+60 °C

Ambient humidity: < 95 %, non-condensing

Protection rating, solenoid valve: IP65¹⁾ + IP67¹⁾ for properly wired devices with inserted and tightened push-in connections.

Protection rating, motor valve: IP54¹⁾ for MFC with motor valve Type 3280
IP50¹⁾ for MFC with motor valve Type 3285
for properly wired devices with inserted and tightened push-in connections.

Operating pressure, solenoid valve: max. 10 bar (depending on the nominal diameter of the solenoid valve)

Operating pressure, motor valve: max. 22 bar (depending on the nominal diameter of the motor valve)

¹⁾ IP50, IP54, IP65 and IP67 protection ratings have not been evaluated according to UL 61010 but determined by Bürkert.



WARNING!

Risk of injury caused by pressure, medium escape!

Important device-specific data are indicated on the nameplate and calibration plate.

- ▶ Only use the device for the specified operating medium.
- ▶ Do not exceed the specified calibration pressure.

6.3.1 Quality of the operating medium

For the required measurement and control precision and to meet the safety requirements, the gas or gas mixture must meet the following quality criteria according to standard ISO 8573-1 (Compressed Air - Part 1: Contaminants and purity classes):

Maximum particle size:	Class 2:	1 µm
Maximum particle density	Class 2:	1 mg/m ³
Maximum dew point under pressure:	Class 4:	3 °C
Maximum oil concentration	Class 1:	0.01 mg/m ³

For further information see ISO 8573-1.

Other hazardous gases are possible on demand; under normal operating conditions the devices do not release any gas.

6.4 Mechanical data

Dimensions:	See datasheet
Weight:	See datasheet

Materials:

Base block	Aluminium or stainless steel 1.4305
Housing:	Die-cast aluminium, painted
Sealing material:	See nameplate

Other parts of the solenoid

valve in contact with the medium: 1.4310, 1.4113, 1.4305

Other parts of the motor

valve in contact with the medium: 1.4310, 1.4305, Al₂O₃, PPS GF40, PEEK

6.5 Fluid data

Calibration medium:	Operating gas or air
Mass flow range ref. to N ₂ (l _N /min):	16... 2500
Measurement accuracy	
With solenoid valve	± 1.5 % of reading ± 0.3 % of full scale (after 1 min warm-up time)
With motor valve	± 2 % of reading ± 0.5 % of full scale. (after 1 min warm-up time)
Measurement range/control range:	1:50 ²⁾

²⁾ Larger measuring range available on request.

Repeat accuracy: ±0.1% of full scale

Operating medium: See nameplate (quality classes according to DIN ISO 8573-1, see chap. 6.3.1).

6.5.1 Pressure loss diagram (MFM)

An MFM has a pressure loss depending on the flow rate, the connection size and the density of the operating gas. The pressure loss can be determined with the following diagram.

The diagram shows the air pressure loss in the device for three different base bodies (up to 100 NI/min, 100...500 NI/min, and 500...1500 NI/min) and 4 different connection sizes (1/4", 1/2", 3/4" and 3/8"). IN

Example:

If the flow rate is 1400 NI/min and the connection size is 1/2" then Δp_{air} is 140 mbar.

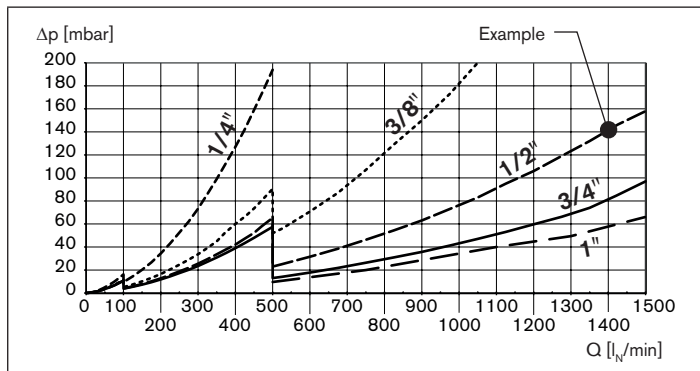

Fig. 5: Pressure loss diagram, for air, with a 250 µm input filter

For operating gases other than air, the pressure drop can be determined as follows:

1. Determine the pressure loss Δp_{air} with the diagram (approach $Q_{\text{gas}} = Q_{\text{air}}$).
2. Calculate Δp_{gas} with the following formula.

$$\Delta P_{\text{Gas}} = \Delta P_{\text{air}} \cdot \sqrt{\frac{\rho_N^{\text{Gas}}}{\rho_N^{\text{air}}}}$$

Under the root are the densities of the operating gas and of air in the normal state according to DIN 1343 ($P_N = 1013.25 \text{ mbar}$, $T_N = 273.15 \text{ K}$).

6.6 Electrical data



WARNING!

For UL-certified components, only use limited power circuits of „NEC Class 2“.

Operating voltage

MFC:

24 V DC ± 10 %;
residual ripple < 2 %

MFM:

24 V DC ± 10 %

Maximum power consumption:

see nameplate of the device or the related supplement for types 8741 / 8742 / 8746 at www.burkert.com

Communications interface:	büS or CANopen
LEDs, MFM / MFC with solenoid valve:	1 LED (conforms to Namur NE 107*) to indicate the status of the device
LEDs, MFM / MFC with motor valve:	1 LED (conforms to Namur NE 107*) to indicate the status of the device 1 LED to indicate the status of the motor valve
Electrical connections:	Round plug connector, M12 plug, 5-pin, coding A

* *NAMUR recommendations (NE) 107: self-monitoring and diagnosis of field devices.*

Standards committee for measurement and control technology (NAMUR) is an international association of users of automation systems for the process industry.

6.7 Markings



WARNING!

Risk of injury caused by pressure, medium escape!

Important device-specific data are indicated on the nameplate and calibration plate.

- ▶ Only use the device for the specified operating medium.
- ▶ Do not exceed the specified calibration pressure.

6.7.1 Calibration plate

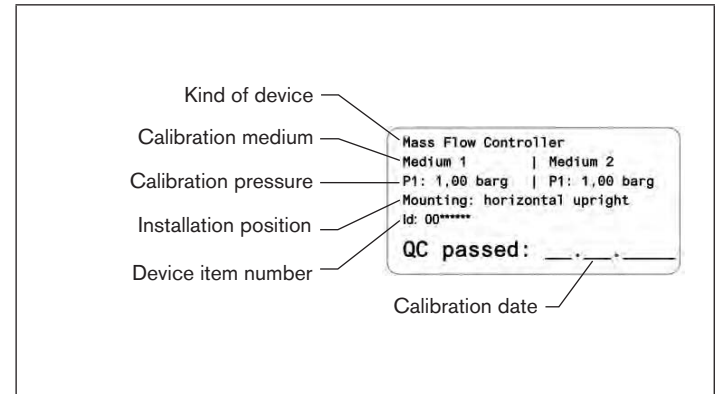
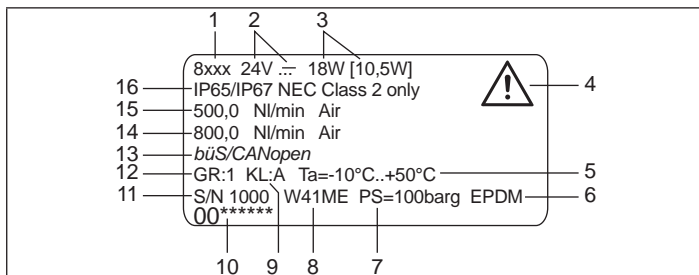

Fig. 6: Description of the calibration plate

6.7.2 Standard nameplate



1. Type of the device
2. Supply voltage, direct current
3. Consumption according to UL 61010-1 [typical consumption ¹⁾]
4. Warning symbol: observe the Operating Instructions delivered with the device.
5. Ambient temperature
6. Sealing material
7. Burst pressure
8. Manufacturing code
9. Class of the valve (according to the DVGW ²⁾)
10. Device item number

¹⁾ Conditions: ambient temperature 23 °C, nominal flow rate 100%, regulation for 30 minutes

²⁾ DVGW = Deutsches Verein des Gas- und Wasserfaches

11. Serial number
12. Category of the device
13. Communication interface
14. Nominal flow rate (Q_{nominal}), units and operating medium gas 2
15. Nominal flow rate (Q_{nominal}), units and operating medium gas 1
16. Protection rating

Fig. 7: Description of the nameplate (example)

6.7.3 Additional marking

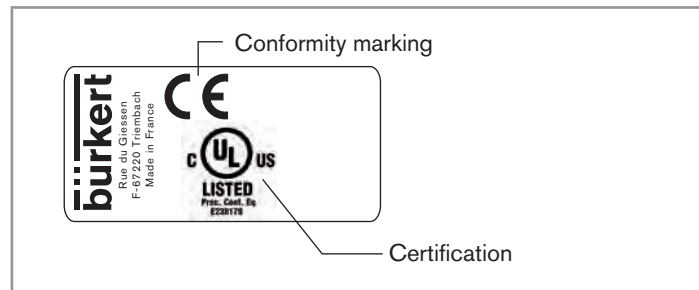

Fig. 8: Description of the additional marking



Find the description of the older markings on the device in the supplement at www.burkert.com

7 INSTALLATION

7.1 Safety instructions



DANGER

Danger due to high pressure in the installation/device.

- ▶ Before working on the installation or device, cut the pressure and vent and drain the pipes.

Risk of injury from electric shocks.

- ▶ Before working on the installation or device, switch off the power and ensure that it cannot be reactivated.
- ▶ Observe the applicable accident protection and safety regulations for electrical equipment.

Risk of injury from medium escape!

- ▶ Observe the applicable accident protection and safety regulations relating to the operating medium used.



WARNING!

Danger of injury from improper installation!

- ▶ The installation must only be carried out by trained personnel using suitable tools.
- ▶ Secure the system against unintentional actuation.
- ▶ Ensure a controlled restart after installation.

NOTE!

Malfunction due to contamination.

If contaminated operating fluids are used, install a filter upstream of the device to make sure the MFC will perfectly operate. See chap. [6.5 Fluid data](#).

NOTE!

Risk of breakage!

Do not use the actuator housing of the motor valve as a lever arm.

Sequence of steps for installing the type 8746:

1. Mechanical installation



Note installation position!

2. Fluid system installation

3. Fieldbus setting



The fieldbus is preset at the factory.

Changes to this setting should be performed before the electrical installation. The switch for setting the fieldbus is difficult to access after the electrical installation.

3. Electrical installation

Ensure the power supply has sufficient output!

7.2 Before installation

- Before installation of the fluid connections to the device, remove all dirt from the pipes and fluid carrying components of the system.
- Install a suitable filter in front of the device (mesh size $\leq 25 \mu\text{m}$) to ensure the cleanliness of the operating medium.

7.3 Mechanical installation

Observe the installation position given on the calibration plate or in the calibration protocol.

7.4 Fluid system installation



DANGER!

Danger due to high pressure in the installation/device.

- ▶ Before working on the installation or device, cut the pressure and vent and drain the pipes.

Select the fluid connections according to the maximum mass flow rate. No inlet section is required.

On request, the device can be supplied with the fluid connections fitted.



WARNING!

Danger due to leakage!

At low mass flows and high pressures, particular attention must be paid to the tightness of the system in order to prevent incorrect metering or leakage of the operating medium.

To ensure a secure seal

- ▶ Install the fittings without subjecting them to any stresses
- ▶ Use compression fittings to ensure sealing of the system.
- ▶ Use a pipe with a suitable diameter and a smooth surface.

Procedure:

The fluid connection was, as an example, declared relating to the front of the device but also applies to the connection on the rear of the device.

- Cut the pipe squarely [1] and deburr [2].

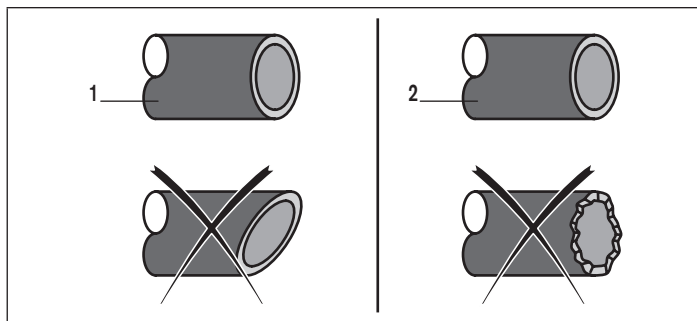

Fig. 9: Cutting the pipe and deburring

Type 8746

Installation

- Remove the protective cap with which the port is closed.
- Slide the union nut [A] and then the clamping ring onto the line.

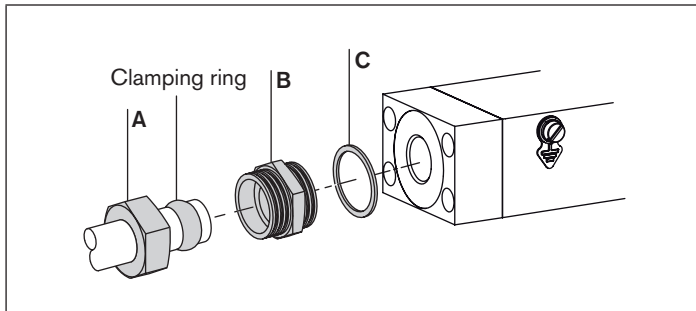

Fig. 10: Slide the union nut and clamping ring onto the pipe.

- Fix the sealing ring [C] and the connecting thread [B] to the device (tightening torque 25...28 N·m, i.e. 18,44 lbf·ft...20,65 lbf·ft).

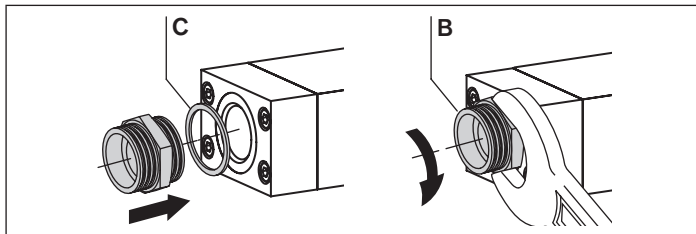

Fig. 11: Fix the sealing ring and screw on the connecting thread

- Insert the line and tighten the union nut [A] by hand.

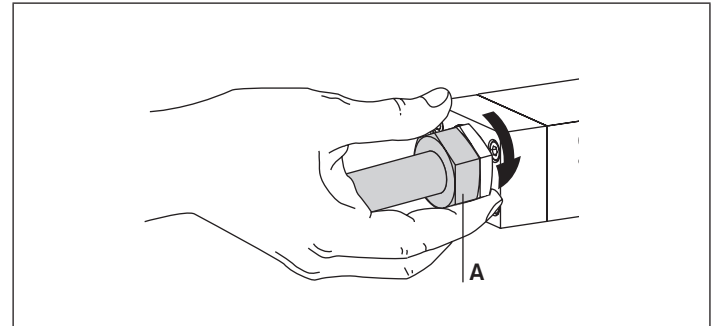

Fig. 12: Insert pipe and tighten the union nut.

- Tighten the lock nut with an open-end spanner so that the connection is leak tight (tightening torque 25...28 N·m, i.e. 18,44 lbf·ft...20,65 lbf·ft).

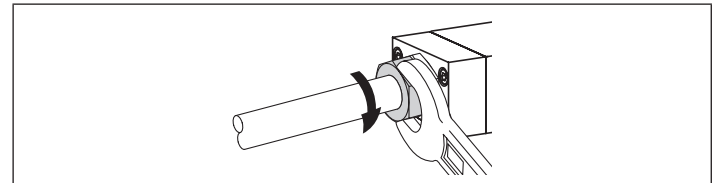

Fig. 13: Tighten the union nut.

- Now make the fluid connection to the back of the device in the same way.

7.5 Installation and removal of the impact protection cover and blind plug

The impact protection cover is designed for use in an Ex. area. When the device is used in a non-Ex. area, use of the impact protection cover may be omitted.

The impact protection cover must be removed during the electrical installation. When altering the fieldbus or replacing the configuration memory, the blind plug must also be removed.

Procedure:

- Loosen the 2 mounting screws.
- Remove the impact protection cover.
- Unscrew the blind plugs with a suitable tool (e.g. a screwdriver) by turning it anti-clockwise.
- Adjust the fieldbus (see chap. [7.6](#)) or replace the configuration memory (see chap. [9.6.1](#)).
- Screw the blind plug clockwise using a tool (e.g. a screwdriver) (at a torque between 0,6 N·m...0,8 N·m, i.e. 0,44 lbf·ft...0,59 lbf·ft)
- Make the electrical connection (see chap. [7.7](#)).
- Attach the impact protection cover. The locking hook of the impact protection cover must lie in the notch of the housing.

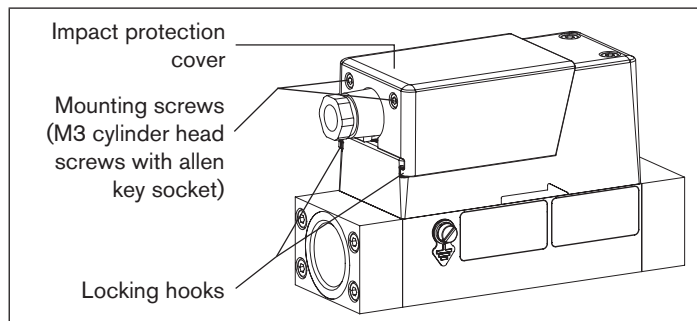

Fig. 14: Attaching the impact protection cover

- Tighten the mounting screws (at a torque between 0,8 N·m...1 N·m, i.e. 0,59 lbf·ft...0,74 lbf·ft).

7.6 Setting up the fieldbus

büS or CANopen can be selected as the standard for the fieldbus.



The fieldbus is preset at the factory. Changes to this setting should be performed before the electrical installation. The switch for setting the fieldbus is difficult to access after the electrical installation.

There is a switch on the inside of the device for setting the fieldbus. The impact protection cover and the blind plugs must be removed for access (see installation and removal of the impact protection cover in chap. [7.5](#)).

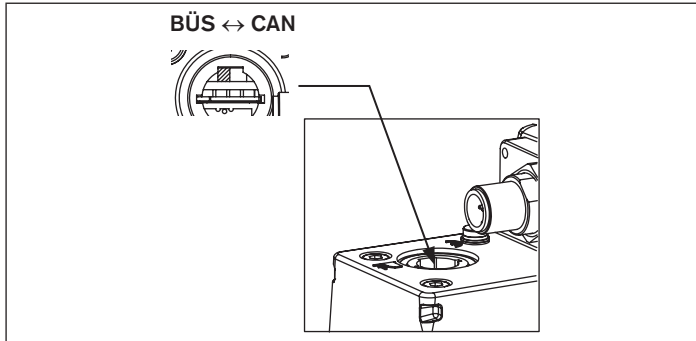

Fig. 15: Switch for setting the fieldbus

! The configured fieldbus is accepted by the device after a restart.

7.7 Electrical installation

! **DANGER**

Risk of injury from electric shocks.

- ▶ Before working on the installation or device, switch off the power and ensure that it cannot be reactivated.
- ▶ Observe the applicable accident protection and safety regulations for electrical equipment.

NOTE!

Requirements for the proper function of the device!

- ▶ Use a power supply with sufficient power output.
- ▶ Pay attention to the maximum permissible residual ripple on the operating voltage (residual ripple < 2 %).
- ▶ Use only shielded cables with a braid or foil shield.

7.7.1 Connect the power supply and communication cable

Electrical pin assignments:

M12 plug, 5-pin	
Pin	Assignment
1	Screen
2	24 V
3	DGND
4	CAN_H
5	CAN_L

M12 thread connected to FE

Fig. 16: Round plug connector, M12 plug, 5-pin, coding A

Procedure:

- Remove the impact protection cover (see installation and removal of the impact protection cover in chap. 7.5).
- For ATEX version, remove the M12 sealing cap.
- Screw in the M12 female connector (at a torque between 0,4 N·m...0,8 N·m, i.e. 0,29 lbf·ft...0,59 lbf·ft: also obey the instruc-

tions given by the manufacturer of the M12 female connector).

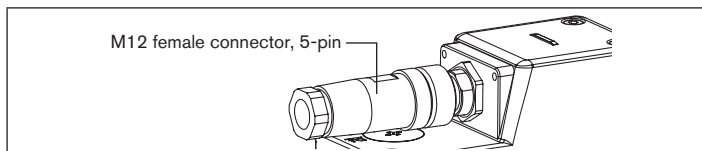

Fig. 17: Screwing in the M12 female connector

→ Install the impact protection cover (see chap. 7.5).

7.8 Connecting the functional earth



WARNING!

Danger of ignition and fire due to electrostatic discharge!

An electrostatic discharge of the device can ignite combustible gas vapours.

- ▶ The housing is connected via a **short** cable with a **large** cross-section to the functional earth (FE) to avoid a build up of electrostatic charge.

Danger from electromagnetic fields!

If the functional earth (FE) is not attached, the provisions of the EMC regulations are not met.

- ▶ The housing is connected via a **short** cable with a **large** cross-section to the functional earth (FE).

There are two screws that can be used for either the functional earthing or the earthing of the device (M3 screw at a torque between 0,6 N·m...0,8 N·m, i.e. 0,44 lbf·ft...0,59 lbf·ft; M4 screw at a torque between 1,8 N·m...2 N·m, i.e. 1,33 lbf·ft...1,47 lbf·ft).

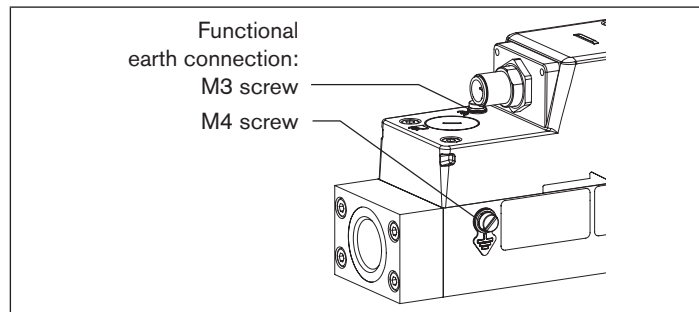

Fig. 18: Connection options for functional earthing FE

7.9 Connecting the cable screen

NOTE!

Requirements for the proper function of the device!

The cable shield must be attached to functional earth FE on the two outermost devices.

Devices which are connected to the trunk line using a drop line longer than 3 m, must also have their cable shielding attached.

Procedure:

→ Connect the cable screen via pin 1 of the M12.

8 COMMISSIONING

8.1 Safety instructions



WARNING!

Danger of injury from improper operation!

Improper operation can lead to injuries and damage to the device and its environment.

- ▶ Before commissioning, it must be ensured that the operating personnel are familiar with, and fully understand, the content of this operating manual.
- ▶ The safety information and the intended use must be observed.
- ▶ Only properly trained personnel may commission the installation/device.

Sequence of steps for commissioning:

- 1. Pressurise the lines with operating medium.
- 2. Flush the lines with operating medium at the calibration pressure and then vent them completely.
- 3. Run the *AUTOTUNE* function.
Only required if the operating medium is not the calibration medium or if the pressure conditions have changed. (See chap. [9.7.1 AUTOTUNE function page 29](#)).
- 3. Regular operation.

9 OPERATION AND FUNCTION

9.1 Safety instructions



WARNING!

Danger due to improper operation!

Improper operation can lead to injuries and damage to the device and its environment.

- ▶ The operating personnel must have read and understood the content of this manual.
- ▶ The safety information and the intended use must be observed.
- ▶ Only properly trained personnel may operate the installation/device.

The device is operated via fieldbus communication.

The connection to a PC is made via the communication interface using the Bürkert-Communicator software.

The device has an LED to display the device status; the colour and status of the LED change according to NAMUR NE 107. An MFC with motor valve has a second LED to indicate the status of the valve (see chap. [9.4](#)).

9.2 Normal control mode

After applying the operating voltage, the device enters a short initialisation phase and then switches to AUTOMATIC operating mode.

The mass flow is controlled via the setpoint sent via the fieldbus.

The control parameters are set so that changes in the setpoint are effected as quickly as possible and without significant overshooting.

The measured value for the mass flow-rate is made available via the fieldbus communication interface.

9.3 Device status LED

The device has an LED to display the device status, the colour and status change based on NAMUR NE 107.

If more than one device status exists simultaneously, the device status with the highest priority is displayed.



A detailed description of the displayed device status and see chap. [11.1 Display of the device status on page 34](#)

The following table applies from software version A.08: It corresponds to NAMUR NE 107.

LED according to NE 107	Description	Meaning
Red	Failure, error or fault	Due to a malfunction in the device or on its periphery, the measured value (of an MFM) is not valid or the controlled operation (of an MFC) is not possible.
Orange	Function check	The device is being worked on; output signal (of an MFM) is therefore temporarily invalid or the controlled operation (of an MFC) is therefore temporarily not possible.

LED according to NE 107	Description	Meaning
Yellow	Out of specification	The ambient conditions or process conditions for the device are outside the specified ranges. Device internal diagnostics point to problems in the device or with the process properties.
Blue	Maintenance required	The device is still measuring (MFM) or in controlled operation (MFC), however a function is briefly restricted. → Do the required maintenance operation.
Green	Diagnostic active	Device is operating faultlessly. Status changes are shown in color. Messages are transmitted via any connected fieldbus.
White	Diagnostic inactive	Device is switched on. Status changes are not shown. Messages are not listed nor transmitted via any connected fieldbus.

Tab. 1: Description of the device status LED

9.3.1 Blinking of the device status LED

When the device status LED is blinking, a connection between the device and the PC-Software „Bürkert-Communicator“ is established.

9.4 LED to indicate the motor valve status

An MFC with motor valve has a second LED to indicate the status of the motor valve; the colour and the status of the LED are described in the following table.

Colour of the LED	Status	Status of the motor valve
none	LED out	Valve is not energized
white	lit	Normal operation
yellow	lit	Valve completely open
green	lit	Valve closed
red	flashing, colour alternating with the colours indicating the valve position	Error
yellow	flashing, colour alternating with the colours indicating the valve position	Out of specification: the ambient conditions or process conditions for the motor valve are outside the specified ranges.

Tab. 2: Description LED motor valve status

9.5 Setting up the fieldbus

→ Refer to chap. [7.6](#).

9.6 Replaceable configuration memory

The device has a replaceable configuration memory, on which the device-specific data is stored.

The device is delivered with the configuration memory inserted.

The configuration memory enables the exchange of specific data with devices having the same ID number. For example, to transfer the data from a faulty unit to a new device.

The configuration memory holds, for example, the baud rate, the address and/or the designations of the measuring points of the device.

If, at restart, there are device-specific data on the configuration memory inserted, then the device adopts this data.

If there are no device-specific data on the configuration memory, the device loads its own data onto the card.



A list of the stored data can be found in the Help for the EDS file (download from www.burkert.com).

NOTE!

If the configuration memory is faulty or lost, obtain a new configuration memory from your local Bürkert sales office. See chap. [12.1 Electrical Accessories](#).

9.6.1 Replacing the configuration memory



- Before replacing the configuration memory of the device, remove the blind plug (see chap. 7.5).
- Pay attention to the direction of insertion: see Fig. 19.

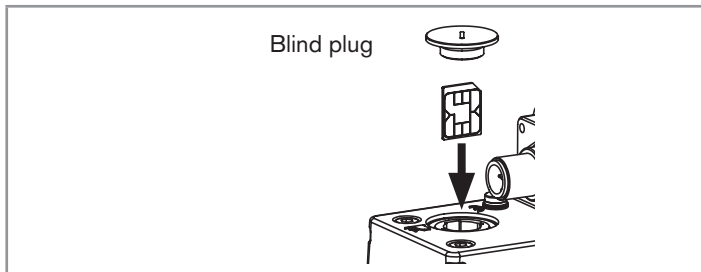
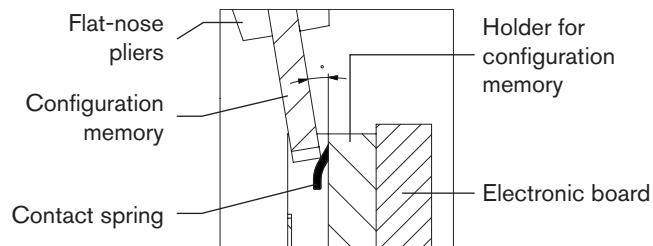

Fig. 19: Insertion direction for the configuration memory

→ Slide the configuration memory into the device as shown in Fig. 20.

1. Grip the configuration memory with flat nose pliers.
2. Insert the configuration memory at an angle.
3. Apply pressure to overcome the counter force of the spring contact.



4. After overcoming the force of the spring, insert the configuration memory vertically.

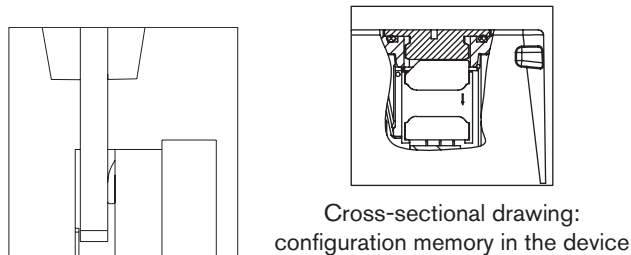

Fig. 20: Replacing the configuration memory

9.7 Functions

9.7.1 AUTOTUNE function

Function optimisation of the MFC control parameters.



For the MFC, the *AUTOTUNE* function is set at the factory. This is done at the operating pressure and with the calibration medium specified in the calibration protocol. A re-run of this function is not normally necessary.

However, a re-run of the *AUTOTUNE* function is required in the following cases:

- If the pressure conditions in the installation have changed.
- If the operating medium is not the same as the calibration medium.

Description:

With the *AUTOTUNE* function, the control parameters for the device which are dependent on the conditions of the installation, are calculated and optimised.

The proportional valve is activated according to a pre-defined scheme, by which the mass flow changes. Certain control settings are then adapted to local conditions. Optimisation is carried out according to the criteria for as short a recovery time as possible, without overshoot.



WARNING!

Danger from flowing gas!

While the *AUTOTUNE* function is running, the gas flow may be greater than the nominal flow.

- ▶ Before running *AUTOTUNE*, check whether a hazard could arise through an increased gas flow and take appropriate measures to ensure safety.

During the *AUTOTUNE*:

- Do not interrupt the power supply to the MFC.
- Keep the supply pressure constant.



The *AUTOTUNE* function is triggered via the fieldbus.

- During the running of the *AUTOTUNE* function, the LED on the device changes its color: see chap. [11.1 Display of the device status on page 34](#).
- The flow control of the MFC is suspended.
- After completion of the *AUTOTUNE*, the device returns to its previous operating state.
- After successful running of *AUTOTUNE*, the optimised control settings are transferred to the hard memory of the device.

9.7.2 In the büS network, other participants process the process values

The device can receive and process the process values from other büS participants in a büS network.

For example, another bus participant can provide the MFC with a setpoint or the MFC/MFM can send its process values to other büS participants. In this way, the current measured value can be received by a different device.

Bürkert-Communicator software is required to configure this function (see chap. [12.3 PC Software](#)).



The configuration procedure is described in the device-specific Help in Bürkert-Communicator (refer to the related Operating Instructions).

9.7.3 Specifying the *SETPOINT SOURCE*

The MFC can specify controlling setpoints from various sources. It is possible to switch between *SETPOINT SOURCES* during operation.

The change of *SETPOINT SOURCE* occurs via

- a setting in the Bürkert-Communicator software (see chap. [12.3 Bürkert-Communicator \(PC software\)](#)) or
- by changing an EDS object of the device.



The *SETPOINT SOURCE* setting is normally retained after a restart. However, this is not the case if the device performs a *SYSTEM ANALYSIS* function.

AUTOMATIC function:

If the AUTOMATIC setpoint source is selected, a standard setpoint is used which is specified via the CANopen or büS fieldbus. This standard setpoint can be manipulated by other fieldbus participants.

If different fieldbus participants simultaneously specify a setpoint for the device, it is always the most recent value that is used for control.

MANUAL SETPOINT function:

The manual specification of a setpoint is used independently of the standard setpoint used in AUTOMATIC operating mode.

This ensures that the setpoint value for testing purposes or the modification by a display cannot be overwritten from other fieldbus participants.

STORED SETPOINT function:

A fixed setpoint can be applied using this function. This fixed setpoint, which is generally used, remains even when the device is restarted.

CONTROL MODE function:

This function allows the duty cycle to the proportional valve to be specified directly. When this function is activated the current duty cycle is used.

Following a restart of the device, the cycle is set to zero.

SYSTEM ANALYSIS function:

When executing the *SYSTEM ANALYSIS* function, the device operates under the normal conditions of the AUTOMATIC operating mode.

This involves a predefined chronological sequence with setpoints. The resulting diagram can be used in combination with the graphical representation of process values to analyse the system via the Bürkert-Communicator software.

9.7.4 User-defined calibration

The devices are always delivered with a calibration by the manufacturer. Using the Bürkert-Communicator software, a user-defined calibration can be specified on the basis of this calibration. For this purpose, up to 32 calibration points can be specified.



The user-defined calibration procedure is described in the device-specific Help in Bürkert-Communicator (refer to the related Operating Instructions).

9.7.5 Updating the cyclic data

The cyclic data can be updated from the device with a specific cycle time. The cycle time determines the time span in which a process value is updated.

An inhibit time of 100 ms means:

After a period of 100 ms, a new process value is provided via the fieldbus.

For fast processes, the inhibit time for cyclic data can be reduced to as low as 10 ms.

After a restart of the device, the inhibit time is reset to the standard time.



For field bus networks with a high number of participants, a low inhibit time may restrict the transfer of the data from all participants.

It is recommended that the default inhibit time values of the device are always used.

The inhibit time is changed via

- a setting in the Bürkert-Communicator software (see chap. [12.3 Bürkert-Communicator \(PC software\)](#)) or
- by changing an EDS object of the device.



The procedure for changing the cycle time is described in the device-specific Help in Bürkert-Communicator (refer to the related Operating Instructions).

9.7.6 Function FLUSH MODE

The valve can be fully opened with the help of an acyclic command or by specifying the double nominal flow rate as a cyclic command.

9.7.7 Setpoint values without communication

The setpoint value of an MFC can be specified separately, without communication with an external setpoint provider (e.g. a PLC). In this way the setpoint value can be kept constant in event, for example, of a break in communication with the PLC.



By using this function, medium can also flow without communication. In this case, the user must pay attention to the safety of the process.



The procedure for using these setpoint values is described in the device-specific help in the Bürkert-Communicator (refer to the related Operating Instructions) or in the documentation of the EDS file (download at www.burkert.com).

10 MAINTENANCE

The device is maintenance-free, provided that no heavily contaminated media are used and that it is operated according to the instructions in this manual.

10.1 Maintenance for operation with heavily contaminated media

DANGER

Danger due to high pressure in the installation/device.

- ▶ Before working on the installation or device, cut the pressure and vent and drain the pipes.

Risk of injury from electric shocks.

- ▶ Before working on the installation or device, switch off the power and ensure that it cannot be reactivated.
- ▶ Observe the applicable accident protection and safety regulations for electrical equipment.

WARNING!

Danger of injury from improper maintenance work!

- ▶ Maintenance must only be performed by trained personnel using suitable tools.
- ▶ Secure the system against unintentional actuation.
- ▶ Ensure a controlled restart after maintenance.



WARNING!

Risk of injury from malfunction and failure by opening the housing!

There are sensitive parts inside the device to control the flow and for measurement of the flow rate.

- ▶ Do not open the device housing.
- ▶ Only the cleaning and maintenance work described in this manual may be carried out on the device.
- ▶ Further work and calibration may only be performed by the manufacturer.

If a heavily contaminated operating medium is used:

- Regularly inspect the contamination of the inlet filter [5] (see [Fig. 21](#)).
- Clean or replace the inlet filter when required, as described below.



For spare parts, see chap. [12.5 Spare parts](#).

10.1.1 Clean the inlet filter

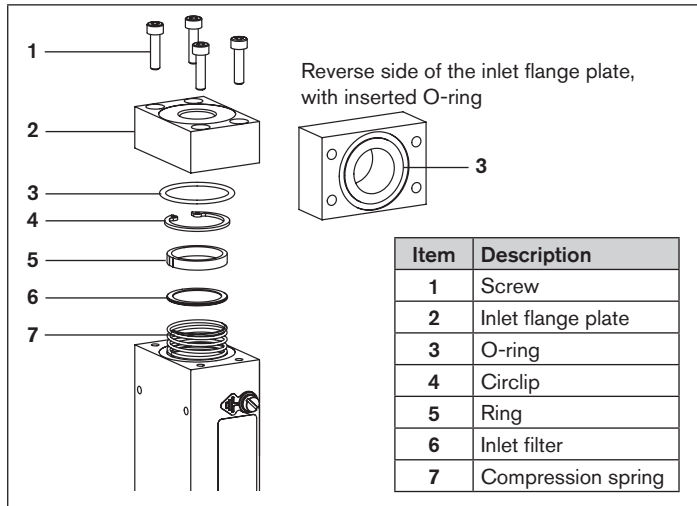

Fig. 21: Clean the inlet filter

- Position the device upright with the fluid inlet at the top.
- Remove the inlet flange plate [2] by loosening the screws [1] (see Fig. 21).
- The O-Ring [3] remains in the groove on the rear side of the inlet flange plate.

- Remove the circlip [4] using a pair of circlip pliers.

⚠ After the circlip is removed, the inlet filter [6] and the ring [5] are pushed out by an internal tensioned compression spring.

- Clean the inlet filter [6].

⚠ Do not clean with tap water!
Clean with acetone, isopropanol or compressed air.

- Dry the inlet filter [6] after cleaning.

- Push the compression spring [7] together with the inlet filter [6] back into the base block and secure them with the circlip [4].

⚠ Before screwing back on the inlet flange plate, make sure that the O-ring [3] is correctly positioned in the inlet flange plate groove.

- Screw on the inlet flange plate [2].

10.2 Cleaning and recalibration at the factory

If the sensor is contaminated or damaged by operation, it may be that the signal for the mass flow rate no longer corresponds to the actual mass flow rate.

In this case the sensor must be replaced and recalibrated by the manufacturer.

11 DEVICE STATUS/TROUBLESHOOTING

11.1 Display of the device status

The device has an LED to display the device status, the colour and status change based on NAMUR NE 107.

If more than one device status exists simultaneously, the device status with the highest priority is displayed.

The following table applies from software version A.08: It corresponds to NAMUR NE 107.



Find the description to the device status LED for the software versions prior to A.08 in the related supplement at www.buerkert.com.

LED according to NE 107	Description	What to do?
OFF	The device is not energized.	Energize the device.
Flashing (any colour)	Device is selected using the Bürkert-Communicator software.	After 10 seconds, the device automatically returns to the previous status.
Green	The device is energized.	The device is in AUTOMATIC or STORED SETPOINT operating mode (see chap. 9.7.3.)
Red	Faulty sensor.	Maintenance is needed – Contact the manufacturer.
	Faulty memory.	
	Faulty device.	
	AUTOTUNE faulty and aborted.	Restart <i>AUTOTUNE</i> .
	Supply voltage out of the error range, potential destruction of the device.	Operate the device within the specifications.
	Device cannot find participants.	Check the wiring. Device described in conjunction with other participants.

Type 8746

Device status/Troubleshooting

LED according to NE 107	Description	What to do?
Red	büS only: Device does not find the process value to be processed.	Check of the allocation of the process value to be processed. Check the defective assigned büS participant. Assigned buS participant provides no cyclic data.
	Bus error (e.g. short circuit).	Check the wiring.
Orange	AUTOTUNE active	-
	Calibration activated	-
	Control loop disabled, direct specification of the variable to the valve.	-
	MANUAL SETPOINT or CONTROL MODE as setpoint source.	-
	SYSTEM ANALYSIS function active	-
	büS only: Device searches assigned participants.	-
	büS only: Manually configured device without address	Search can take up to one minute.
Yellow	Medium temperature, device temperature or supply voltage out of specification, potential destruction of the sensor or device.	Operate the device within the specifications.
	The control variable for the proportional valve has (almost) reached 100%. The setpoint cannot be attained.	Increase the operating pressure (observe the maximum permissible supply pressure). Check the pressure drop in the pipe and reduce it if necessary. Check the dimensions of the installation. Check the filters installed in the pipe and clean them if necessary.
	Other fieldbus participant using the same node ID.	Assign the participant an individual node ID.
Blue	Memory error.	Maintenance is needed –
	Error detected in the calibration curve.	Contact the manufacturer.

Fig. 22: Description: LED indicating the device status and measures

11.2 Troubleshooting for the device

Problem	Possible cause	What to do?
The Namur LED goes out periodically	The power supply is intermittently dropping – the device therefore performs a reset.	Use a power supply with sufficient power output.
	The voltage drop in the connecting cable is too large.	Increase the cross-section of the cable. Reduce the cable length.
The exchange device adopts none of the values on the configuration memory from the faulty device	The item number of the exchange device differs from that of the defective device.	Values can only be transferred between devices with the same item number.
	Configuration memory is faulty – Device could not write any values to the configuration memory.	Replace the configuration memory and try again to transfer the settings of the defective device to the configuration memory (see chap. 12.1 Electrical Accessories and Fig. 20: Replacing the configuration memory).
The exchange device does not adopt all of the values on the configuration memory from the faulty device	The EDS device description of the exchange device differs from that of the defective device.	Only the existing values of the defective device can be adopted by the exchange device. The new values of the exchange device must be configured using the Bürkert-Communicator software.
Device does not adopt the values of an assigned bus participant	The value to be adopted is not properly assigned in the device.	Assign the value to be adopted in the device using the Bürkert-Communicator software.
	The value to be adopted is not supplied from the assigned bus participant.	Check the instrument of the assigned bus participant.
No mass flow rate	The setpoint is below the zero-point shut-off limit.	Increase the setpoint value to > 2% of the nominal flow rate.
	The device is not in the normal control mode. See chap. 9.2 Normal control mode .	Check whether the device is running one of the functions described in chap. 9.7 .
	The pipes are too large or not yet fully vented.	Vent the pipes. Change the pipe diameter.

Problem	Possible cause	What to do?
Unstable measured value	The functional earth (FE) is not properly connected.	Connect the functional earth with the shortest possible cable, cross-section at least 2.5 mm ² .
	The controller must compensate for irregularities in an unstable pressure supply caused, for example, by pumps.	Install a suitable pressure regulator in front of the device. Install a buffer tank to absorb the pressure fluctuations.
	The residual ripple on the voltage supply is too high.	Use a suitable supply voltage. See technical data.
Setpoint at 0 % but operating medium still flows	The operating pressure is above the tight sealing pressure of the proportional valve.	Reduce the operating pressure. To eliminate the defect, return the device to the manufacturer.
Setpoint value at 0 %, valve is closed, no mass flow, but a non-zero mass flow rate is measured	The installation position of the device is incorrect.	Install the device in the position indicated on the calibration plate or in the calibration protocol and run the <i>AUTOTUNE</i> function to adapt to the operating conditions.
	The operating medium is different from the medium specified during the calibration.	Use the specified operating medium or send the device to the manufacturer for calibration with the new operating medium.
Setpoint value is not reached	The inlet filter is clogged.	Clean or replace the inlet filter.
	The inlet pressure is too low.	Increase the inlet pressure to the calibration pressure value.
	The outlet pressure is too high.	Check whether the fluid connection pipes after the device are dirty and clean if necessary.

Tab. 3: Troubleshooting for the device

11.3 Troubleshooting for the motor valve

Problem	Possible cause	Do the following
LED flashing and red / LED lit and red	Temperature too high	→ Respect the maximum ambient temperature and medium temperature. → After the error has been removed, restart the device (deenergize the device) to turn off the red blinking LED.
	Cable break	→ Check if there are loose connections on the cable between the MFC and the motor valve.
Motor is humming unusually	Gears or motor blocked	→ Send the device back to the manufacturer for repair.

Tab. 4: Troubleshooting for the motor valve

12 ACCESSORIES / SPARE PARTS



CAUTION!

Danger of injury and material damage due to unsuitable parts!

Incorrect accessories and unsuitable replacement parts can cause injuries and damage to the device and its environment.

► Only use original accessories and spare parts from Bürkert.

12.1 Electrical Accessories

Item	Item number
büS stick set (including power supply)	772426
büS stick set (without power supply)	772551
Configuration memory	On request
EDS file	Download from www.burkert.com
Bürkert-Communicator software	Download from www.burkert.com

Tab. 5: Electrical accessories (for further accessories see the device datasheet)



Cable assemblies can be made on request.

12.2 Fluid accessories

The device is equipped with a threaded process connection plate according to DIN ISO 228/1.

A threaded fitting, available as an accessory, is used to connect the device to a pipe:

- The connection to the device side has a DIN ISO 228/1 thread,
- The connection to the pipe side is available in a range of dimensions.
- The fluid connection should be selected with regard to the application.
- Compression or olive-type fittings are suitable for many applications, however alternative fittings can also be used.

12.2.1 Compression fittings

The following compression fittings are available from Bürkert for the device.

Device connection with thread in accordance with DIN ISO 228/1	Pipe diameter	Material	Item number	Item number for seal ring
G 1/4	6 mm	Stainless steel	901 538	901 575
G 1/4	8 mm		901 540	901 575
G 1/4	1/4"		901 551	901 579
G 1/4	3/8"		901 553	901 579
G 3/8	8 mm		901 542	901 576
G 3/8	10 mm		901 544	901 576

G 3/8	1/4 "	901 555	901 580
G 3/8	3/8 "	901 556	901 580
G 1/2	10 mm	901 546	901 577
G 1/2	12 mm	901 548	901 577
G 1/2	1/2 "	901 557	901 581
G 1/2	3/4 "	901 558	901 581
G 3/4	12 mm	901 549	901 578
G 3/4	3/4 "	901 559	901 582

Tab. 6: Compression fittings



The seal for each threaded connection must be ordered separately. Each item number includes one piece.

12.3 Bürkert-Communicator (PC software)

The Bürkert-Communicator PC software enables communication with the device.



Bürkert-Communicator software runs under Windows. It needs to communicate with the device via a USB interface, büS stick (see [Tab. 5: Electrical accessories \(for further accessories see the device datasheet\) page 38](#)).

Bürkert-Communicator software enables:

- the reading of certain specific device data,
- activation of various features,

- modification of certain dynamic properties,
- adjustment of the user-defined calibration curve,
- execution of firmware updates,
- the reading of error memories.

12.4 Additional documentation

- Contamination Declaration, item number 806 075
- Device-specific Help in the Bürkert-Communicator (refer to the related Operating Instructions)
- Help for the EDS file (download from www.burkert.com)
- ATEX supplement for the type 8746 with ATEX certification (download from www.burkert.com)
- Supplement for type 8746 (download from www.burkert.com)
- Cabling guide for EDIP (download from www.burkert.com)
- büS-driver for LabVIEW on request

12.5 Spare parts

Item	Item number
Inlet filter, mesh size 250 µm (standard base body)	on request
Inlet filter, mesh size 25 µm (Base body for large mass flow)	on request

Tab. 7: Spare parts

13 DECOMMISSIONING

13.1 Safety instructions



DANGER!

Danger due to high pressure in the installation/device.

- ▶ Before working on the installation or device, cut the pressure and vent and drain the pipes.

Risk of injury from electric shocks.

- ▶ Before working on the installation or device, switch off the power and ensure that it cannot be reactivated.
- ▶ Observe the applicable accident protection and safety regulations for electrical equipment.



WARNING!

Risk of injury from improper dismantling!

- ▶ Dismantling must only be performed by trained personnel using suitable tools.

Risk of injury from hazardous media.

- ▶ Before disconnecting pipes or valves, flush out hazardous media, release pressure in the pipes and drain.
- ▶ Observe the applicable accident protection and safety regulations relating to the operating medium used.

13.2 Dismantling the device

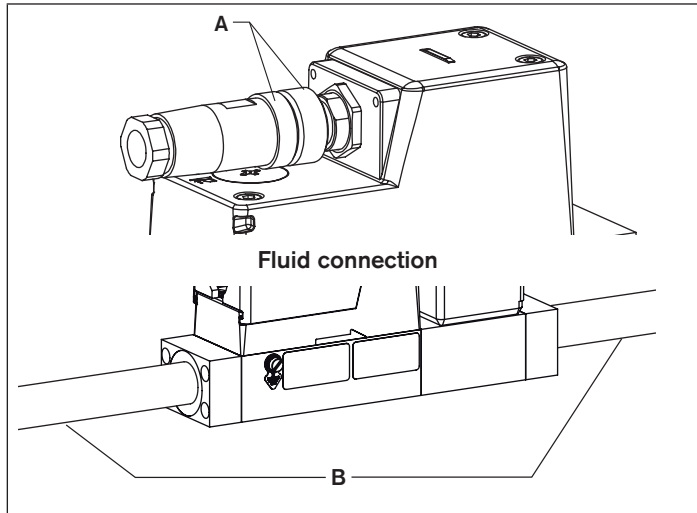

Fig. 23: Dismantling the device

Procedure:

- Relieve the operating medium pressure in the system.
- Flush the device with a neutral medium (e.g. nitrogen)
- Relieve the flushing medium pressure in the system.
- Switch off the power.

- Remove the impact protection cover (see chap. 7.5 Installation and Removal of the Impact Protection Cover).
- Remove the electrical wiring [A].
- Disconnect the fluid connections [B].
- Remove the device.

14 TRANSPORT, STORAGE, DISPOSAL

NOTE!

Transport damage!

Damage can be caused to insufficiently protected devices in transport.

- Remove cables, connectors, separate filters and mounting hardware.
- Clean and vent contaminated devices.
- Close the fluid connections with protective caps to prevent damage and protect the sealing.
- Pack the device in two suitable zip lock bags, to avoid any contamination during the transport.
- Transport the device in an impact-resistant package, protected from moisture and dirt.
- Avoid storage above or below the recommended storage temperature.

Incorrect storage can cause damage to the device.

- Close fluid connections with protective caps.
- Store the device dry and dust-free in sealed zip lock bags!
- Storage temperature -10 ... +70 °C.

Environmental damage due to parts contaminated by media.

- Dispose of the device and its packaging in an environmentally friendly manner!
- Comply with applicable environmental and disposal regulations.

15 RETURNING THE DEVICE



No work or tests will be carried out on the device until a valid Contamination Declaration has been received.

The Contamination Declaration can be downloaded from our homepage or requested from your local Bürkert sales office.

www.buerkert.de → [Service](#) → [Service / Maintenance / Commissioning](#) → [Contamination Declaration](#)

To return a device already in use, a returns number is required.

To return a device that has already been used to Bürkert, proceed as follows:

- Fill out the Contamination Declaration.
- Send the declaration to the address indicated on the form: You will then receive a Returns Number by fax or post from Bürkert.
- Pack the device as described in chap. 14.
- Return the device to Bürkert with the Contamination Declaration, quoting the returns number.

Address:

Bürkert Fluid Control Systems
Corporate Quality / Complaint Management
Chr.-Bürkert-Str. 13-17
D-74653 Ingelfingen
Tel. + 49 (0) 7940 - 10 91 599
Fax + 49 (0) 7940 - 10 91 490
E-Mail: service.international@burkert.com

www.burkert.com