

Type 8695 REV.2

Control Head
Steuerkopf
Tête de commande



Quickstart

English Deutsch Français

We reserve the right to make technical changes without notice.
Technische Änderungen vorbehalten.
Sous réserve de modifications techniques.

© Bürkert Werke GmbH & Co. KG, 2021

Quickstart 2106/02_EU-ML_00815307 / Original DE

1	ABOUT THESE INSTRUCTIONS	4			
1.1	Symbols.....	4			
1.2	Definition of term	4			
2	INTENDED USE	5			
3	BASIC SAFETY INSTRUCTIONS.....	5			
4	GENERAL INFORMATION	6			
4.1	Contact address.....	6			
4.2	Warranty	6			
4.3	Information on the internet	6			
5	SYSTEM DESCRIPTION	7			
5.1	Structure and function.....	7			
6	TECHNICAL DATA.....	8			
6.1	Conformity.....	8			
6.2	Standards	8			
6.3	Licenses	8			
6.4	Operating conditions.....	8			
6.5	Mechanical data	9			
6.6	Type labels.....	9			
6.7	Pneumatic data	10			
6.8	Electrical data.....	10			
7	INSTALLATION	11			
7.1	Safety instructions.....	11			
7.2	Installation of the control head on process valves of series 21xx	12			
7.3	Installation of the control head on process valves of series 20xx	13			
7.4	Manual actuation of the actuator via pilot valve.....	15			
8	PNEUMATIC INSTALLATION	16			
9	ELECTRICAL INSTALLATION	17			
9.1	Safety instructions.....	17			
9.2	Electrical installation, without fieldbus communication.....	17			
9.3	Electrical installation, IO-Link Port Class B and Port Class A.....	18			
9.4	Electrical installation, bÜS	18			
10	CONTROL AND DISPLAY ELEMENTS.....	19			
10.1	Operating state	19			
10.2	Configuration of the buttons.....	19			
10.3	Display of the LEDs	21			
11	START-UP.....	23			
11.1	Safety instructions.....	23			
11.2	Starting the automatic teach function (calibrating the end positions).....	23			
11.3	Setting with Bürkert Communicator	25			
11.4	IO-Link.....	26			
11.5	bÜS.....	27			
12	SAFETY END POSITIONS	27			
13	ACCESSORIES	28			
13.1	Communications software.....	28			
14	PACKAGING, TRANSPORT, STORAGE	28			

1 ABOUT THESE INSTRUCTIONS

The Quickstart contains extremely important information on the device.

→ Keep these instructions ready to hand at the operation site.



Important safety information.

- ▶ Carefully read these instructions.
- ▶ Observe in particular the safety instructions, intended use and operating conditions.
- ▶ Persons, who work on the device, must read and understand these instructions.



The operating instructions can be found on the Internet at:
www.burkert.com

1.1 Symbols



DANGER!

Warns of an immediate danger.

- ▶ Failure to observe the warning may result in a fatal or serious injury.



WARNING!

Warns of a potentially dangerous situation.

- ▶ Failure to observe the warning may result in serious or fatal injuries.



CAUTION!

Warns of a possible danger.

- ▶ Failure to observe the warning may result in moderate or minor injuries.

ATTENTION!

Warns of damage to property.

- ▶ Failure to observe the warning may result in damage to the device or system.



Indicates important additional information, tips and recommendations.



Refers to information in these instructions or in other documentation.

▶ Designates an instruction to prevent risks.

→ designates a procedure that must be carried out.

✓ Indicates a result.

1.2 Definition of term

The term “device” used in these instructions always stands for the control head Type 8695 REV.2.

The term “büs” (Bürkert system bus) used in this instruction stands for the communication bus developed by Bürkert and based on the CANopen protocol.

In these instructions, the abbreviation “Ex” always refers to “potentially explosive atmosphere”

2 INTENDED USE

The control head Type 8695 REV.2 is designed to be mounted on pneumatic actuators of process valves for the control of media. The permitted fluid media are listed in the technical data.

- ▶ Use the device for its intended purpose only. Non-intended use of the device may be dangerous to people, nearby equipment and the environment.
- ▶ Correct transportation, correct storage as well as correct installation, commissioning, operation and maintenance are essential for reliable and problem-free operation.
- ▶ When using the device, observe the permitted data, operating conditions and application conditions. This information can be found in the contractual documents, the operating instructions and on the type label.
- ▶ Use the device only in conjunction with third-party devices and components recommended and authorized by Bürkert.
- ▶ Do not use the device outdoors without protection from the weather.
- ▶ In potentially explosive atmosphere, only use devices approved for use in those areas. These devices are labeled with a separate Ex type label. For such use, note the information provided on the separate Ex type label and the additional explosion-related information or separate explosion-related operating instructions.

3 BASIC SAFETY INSTRUCTIONS

These safety instructions do not consider any contingencies or incidents which occur during installation, operation and maintenance. The operator is responsible for observing the location-specific safety regulations, also with reference to the personnel.



DANGER

Risk of injury from high pressure and discharge of medium.

- ▶ Before working on the device or system, switch off the pressure. Vent or drain lines.

Risk of injury from electric shock.

- ▶ Before working on the device or system, switch off the power supply. Secure against reactivation.
- ▶ Observe applicable accident prevention and safety regulations for electrical equipment.

To prevent injury, ensure the following:

- ▶ Secure device or system to prevent unintentional activation.
- ▶ Only trained technicians may perform installation and maintenance work.
- ▶ Perform installation and maintenance with suitable tools only.
- ▶ Do not make any changes to the device and do not subject it to mechanical stress.
- ▶ Operate the device only in perfect state and in consideration of the operating instructions.
- ▶ Observe the general rules of technology.
- ▶ Install the device according to the regulations applicable in the respective country.

- ▶ Do not feed corrosive or flammable media into the device connections.
- ▶ Do not feed any fluids into the connections of the device.
- ▶ After the process is interrupted, restart in a controlled manner. Observe sequence:
 1. Connect electrical or pneumatic power supply.
 2. Charge the device with medium.
- ▶ Observe intended use.

4 GENERAL INFORMATION

4.1 Contact address

Germany

Bürkert Fluid Control System
Sales Center
Chr.-Bürkert-Str. 13-17
D-74653 Ingelfingen
Tel. + 49 (0) 7940 - 10 91 111
Fax + 49 (0) 7940 - 10 91 448
E-mail: info@burkert.com

International

Contact addresses can be found on the final pages of the printed operating instructions.

And also on the Internet at:

www.burkert.com

4.2 Warranty

The warranty is only valid if the control head Type 8695 is used as intended in accordance with the specified application conditions.

4.3 Information on the internet

The operating instructions and data sheets for Type 8695 can be found on the internet at:

www.burkert.com

5 SYSTEM DESCRIPTION

5.1 Structure and function

The control head Type 8695 can control single or double-acting process valves.

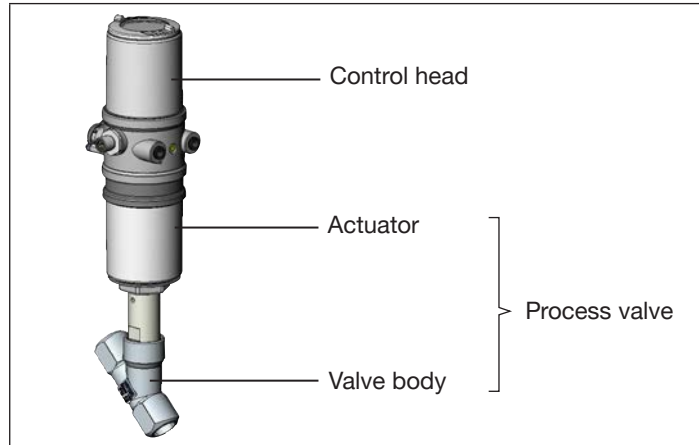

Fig. 1: Structure 1

Depending on the conditions of use, different process valves from the Bürkert range can be combined with the control head. Angle-seat valves, globe valves and diaphragm valves of series 21xx (ELEMENT) and 20xx (CLASSIC) are suitable.

The control head Type 8695 has been optimized for the integrated modular fitting of series 21xx process valves (ELEMENT) with actuator size $\varnothing 50$. Various expansion stages are possible thanks to the modular design.

For installation on the 20xx series (CLASSIC) there is a special model.

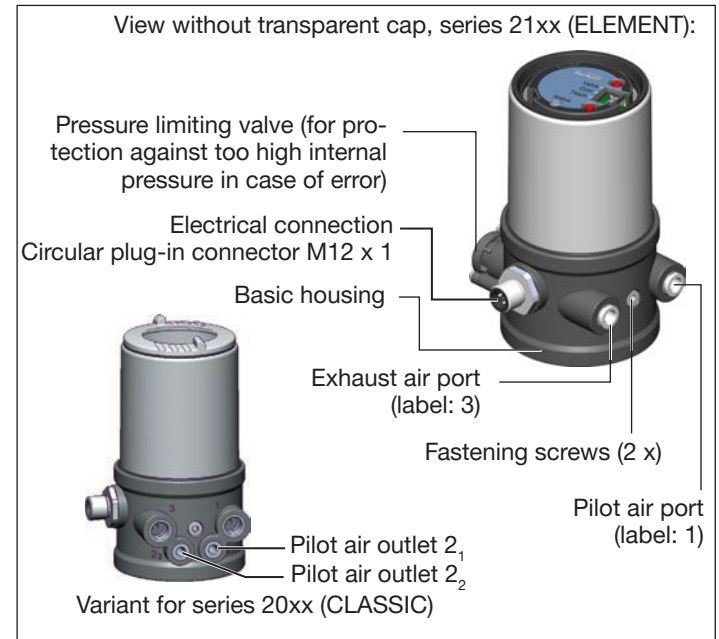

Fig. 2: Structure 2

6 TECHNICAL DATA

6.1 Conformity

In accordance with the EU Declaration of conformity, the control head Type 8695 is compliant with the EU Directives.

6.2 Standards

The applied standards on the basis of which compliance with the EU Directives is confirmed are listed in the EU type examination certificate and/or the EU Declaration of Conformity.

6.3 Licenses

The product is approved for use in zone 2 and 22 in accordance with ATEX directive 2014/34/EU category 3GD.



Observe instructions on operation in an potentially explosive atmosphere (Ex area). Observe the ATEX additional instructions.

The product is cULus approved. Instructions for use in the UL area see chapter [“6.8 Electrical data”](#).

6.4 Operating conditions



WARNING!

Solar radiation and temperature fluctuations may cause malfunctions or leaks.

- ▶ If the device is used outdoors, do not expose it unprotected to the weather conditions.
- ▶ Ensure that the permitted ambient temperature does not exceed the maximum value or drop below the minimum value.

Ambient temperature

see type label

Degree of protection

Evaluated by the manufacturer:	Evaluated by UL:
IP65 / IP67 according to EN 60529 ¹⁾	UL Type 4x Rating indoor only ¹⁾

Operating altitude

up to 2000 m above sea level

Relative air humidity

max. 90% at 55 °C / 60 °C
(non condensing)

¹⁾ Only if cables, plugs and sockets have been connected correctly and in compliance with the exhaust air concept see chapter [“8 Pneumatic installation”](#).

6.5 Mechanical data

Dimensions		See data sheet
Body material	exterior interior	PPS, PC, VA PA6, ABS
Sealing material	exterior	EPDM/FKM
Stroke range of valve spindle		
	21xx series (ELEMENT) and 20xx series (CLASSIC)	2 – 35 mm
	Third-party devices (modified guide element required)	2 – 44 mm

6.6 Type labels

6.6.1 Type label standard

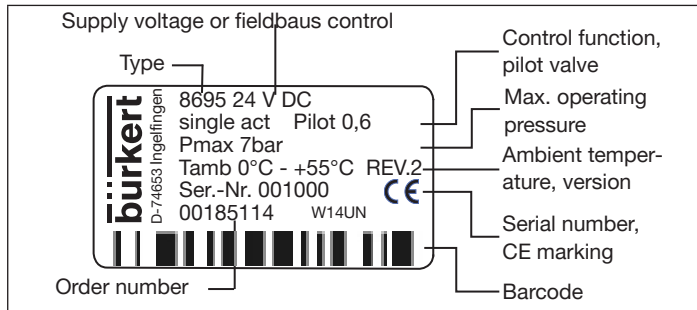

Fig. 3: Type label (example)

6.6.2 UL type label

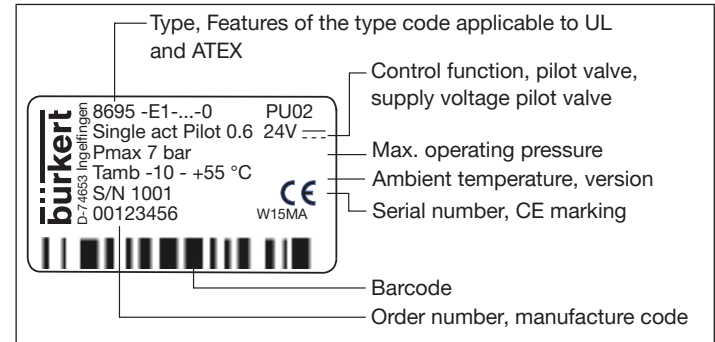

Fig. 4: UL type label (example)

6.6.3 UL additional label

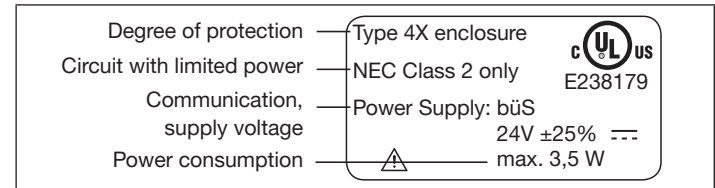

Fig. 5: UL additional label (example)

6.7 Pneumatic data

Control medium	neutral gases, air Quality classes in accordance with ISO 8573-1
Dust content Class 7	max. particle size 40 µm, max. particle density 10 mg/m ³
Water content Class 3	max. pressure dew point -20 °C or min. 10 °C below the lowest operating temperature
Oil content Class X	max. 25 mg/m ³
Temperature range	-10 – +50 °C
Pressure range	3 – 7 bar
Air output of pilot valve	7 l _N /min (for aeration and deaeration) (Q _{Nn} - value according to definition for pressure drop from 7 to 6 bar absolute)
Connections 21xx (ELEMENT)	Plug-in hose connector Ø 6 mm / 1/4" Socket connection G 1/8
20xx (CLASSIC)	Socket connection G 1/8 with M5 connection for connecting to the actuator

6.8 Electrical data



WARNING!

Only circuits with limited power may be used for UL approved components according to "NEC Class 2".

6.8.1 Electrical data without field bus communication

Protection class	III as per DIN EN 61140 (VDE 0140-1)
Connections	Circular plug-in connector (M12 x 1, 8-pin)
Operating voltage	24 V DC ± 25% max. residual ripple 10 %
Power consumption	max. 3.5 W
Output	max. 100 mA per output
Display	max. 20 mA per illustrated illuminated display (LED)
Communications interface	Connection to PC via USB-büS interface set
Communication software	Bürkert Communicator

6.8.2 Electrical data, IO-Link

Protection class	III as per DIN EN 61140 (VDE 0140-1)
Connection	Circular plug-in connector M12 x 1, 5-pin, A-coded

Operating voltage	
System supply (Pin 1+3)	24 V DC \pm 25 % (according to specification)
Actuator supply (Pin 2+5) ²⁾	24 V DC \pm 25 % (according to specification)
Current consumption	
System supply (Pin 1+3)	max. 50 mA
Actuator supply (Pin 2+5)	max. 100 mA, only with installed pilot valves
Total power consumption	max. 3.5 W

²⁾ Actuator supply is galvanically isolated from system supply in accordance with IEC 60664 and for electrical safety in accordance with SELV from IEC 61010-2-201

6.8.3 Electrical data, bÜS

Protection class	III as per DIN EN 61140 (VDE 0140-1)
Connection	Circular plug-in connector M12 x 1, 5-pin, A coded
Operating voltage	24 V DC \pm 25 %
Current consumption	max. 150 mA
Total power consumption	max. 3.5 W

7 INSTALLATION



Only for control head without pre-assembled process valve.

7.1 Safety instructions



DANGER!

Risk of injury from high pressure in the equipment/device.

- ▶ Before working on equipment or device, switch off the pressure and deaerate/drain lines.

Risk of electric shock.

- ▶ Before working on equipment or device, switch off the power supply and secure to prevent reactivation.
- ▶ Observe applicable accident prevention and safety regulations for electrical equipment.



WARNING!

Risk of injury from improper installation.

- ▶ Installation may be carried out by authorized technicians only and with the appropriate tools.

Risk of injury from unintentional activation of the system and an uncontrolled restart.

- ▶ Secure system from unintentional activation.
- ▶ Following assembly, ensure a controlled restart.

7.2 Installation of the control head on process valves of series 21xx

ATTENTION!

When mounting on process valves with a welded connection, follow the installation instructions in the operating instructions for the process valve.

! When the control head is being installed, the collets of the pilot air ports must not be fitted to the actuator.

ATTENTION!

Damaged printed circuit board or malfunction.

► Ensure that the puck is situated flat on the guide rail.

- Align the puck and the control head until
1. the puck can be inserted into the guide rail of the control head (see “Fig. 6”) and
 2. the connection pieces of the control head can be inserted into the pilot air ports of the actuator (see also “Fig. 7”).

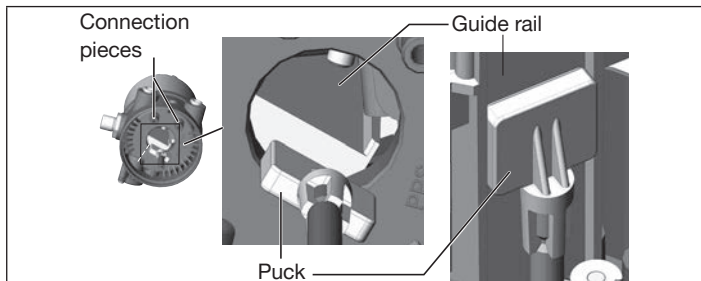

Fig. 6: Aligning the puck

- Push the control head, without turning it, onto the actuator until no gap is visible on the form seal.

ATTENTION!

Too high torque when screwing in the fastening screw does not ensure protection class IP65 / IP67.

► The fastening screws may be tightened to a maximum torque of 1.5 Nm only.

- Attach the control head to the actuator using the two side fastening screws. In doing so, tighten the screws only hand-tight (max. torque: 1.5 Nm).

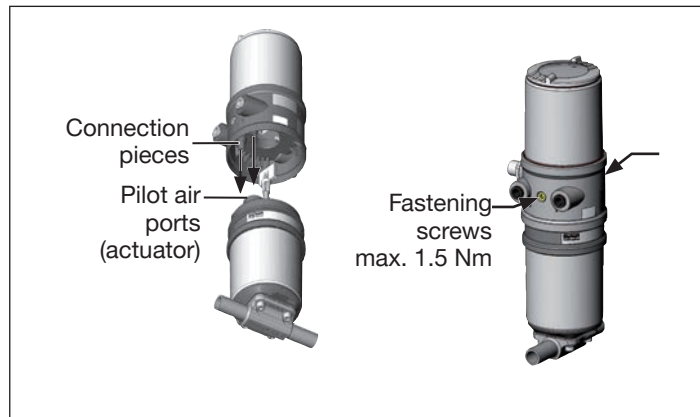

Fig. 7: Installation of control head, 21xx series

7.3 Installation of the control head on process valves of series 20xx

Procedure:

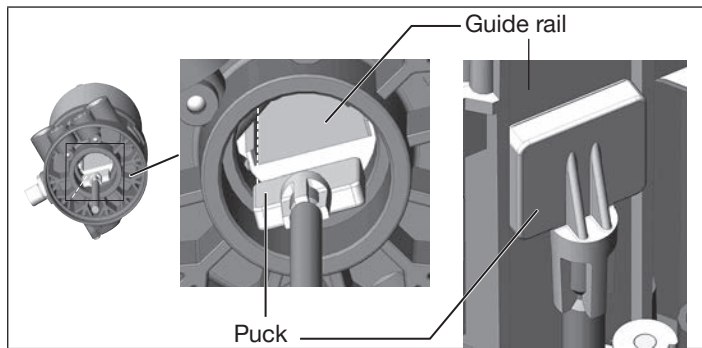

Fig. 8: Aligning the puck

ATTENTION!

Damaged printed circuit board or malfunction.

- ▶ Ensure that the puck is situated flat on the guide rail.

- Push the control head onto the actuator. The puck must be aligned in such a way that it is inserted into the guide rail of the control head (see "Fig. 8").
- Press the control head all the way down as far as the actuator and turn it into the required position.



Ensure that the pneumatic connections of the control head and those of the valve actuator are situated preferably vertically one above the other (see "Fig. 9").

ATTENTION!

Too high torque when screwing in the fastening screw does not ensure protection class IP65 / IP67.

- ▶ The fastening screws may be tightened to a maximum torque of 1.5 Nm only.

- Attach the control head to the actuator using the two side fastening screws. In doing so, tighten the fastening screws hand-tight only (maximum torque: 1.5 Nm).

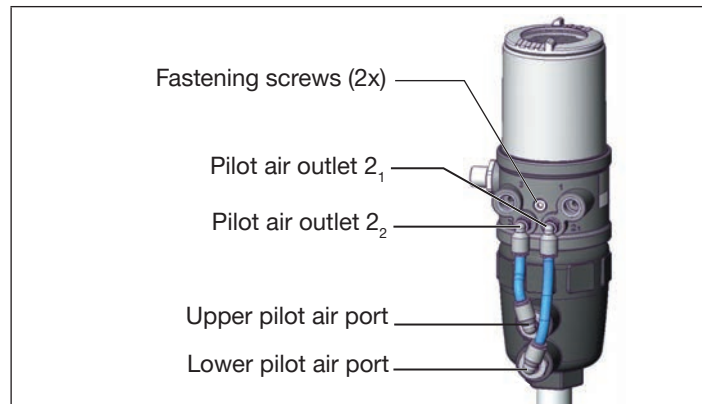

Fig. 9: Installing the pneumatic connection, 20xx series

- Screw the plug-in hose connectors onto the control head and the actuator.
- Using the hoses supplied in the accessory kit, make the pneumatic connection between the control head and actuator with the “Tab. 1: Pneumatic connection to actuator”.

ATTENTION!

Damage or malfunction due to ingress of dirt and moisture.

- ▶ To comply with protection class IP65 / IP67, connect the pilot air outlet (only for CFA or CFB) which is not required to the free pilot air port of the actuator or seal with a plug.



“In rest position” means that the pilot valves of the control head Type 8695 are isolated or not actuated.



If the ambient air is humid, a hose can be connected between pilot air outlet 2_2 of the control head and the unconnected pilot air port of the actuator for control function A or control function B. As a result, the spring chamber of the actuator is supplied with dry air from the vent duct of the control head.

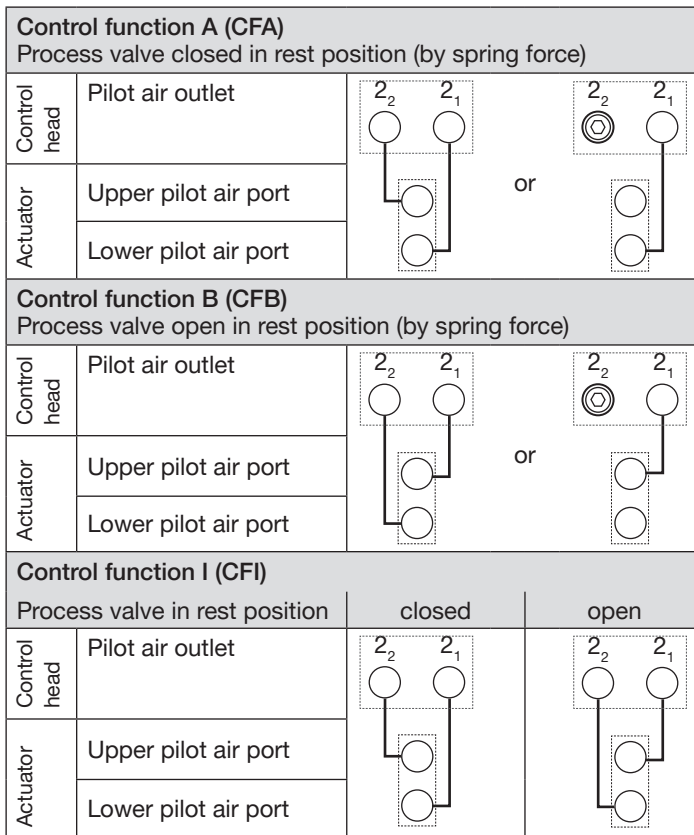

Tab. 1: Pneumatic connection to actuator

7.4 Manual actuation of the actuator via pilot valve

The actuator can be moved without a power supply from the rest position to its end position and back again, *when the control air is connected*.

To do this, the pilot valve must be actuated with a screwdriver.

ATTENTION!

Breakage of the pneumatic connection pieces due to rotational impact.

- ▶ When unscrewing and screwing in the body casing or transparent cap, do not hold the actuator of the process valve but the basic housing.

→ To activate the device manually, unscrew the body casing.

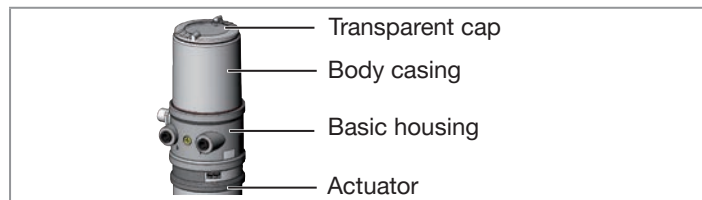

Fig. 10: Opening and closing the device

ATTENTION!

Damage or malfunction due to ingress of dirt or moisture.

To observe the degree of protection IP65 or IP67:

- ▶ Screw in body casing to the stop.

ATTENTION!

The hand lever may be damaged if it is simultaneously pressed and turned.

- ▶ Do not press the hand lever when turning it.

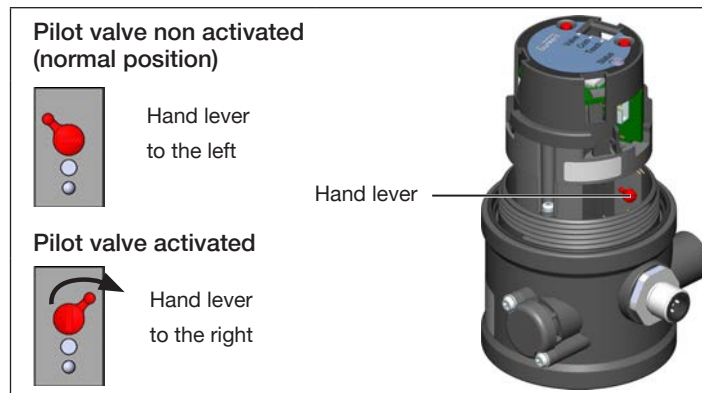

Fig. 11: Pilot valve for aerate and deaerate the actuator

Move actuator to end position

→ Turn the hand lever to the right using a screwdriver.

Note: Do not press the hand lever when turning it

Move actuator back to the rest position

→ Turn the hand lever to the left using a screwdriver.

Note: Do not press the hand lever when turning it

8 PNEUMATIC INSTALLATION



DANGER!

Risk of injury from high pressure in the equipment/device.

- ▶ Before working on equipment or device, switch off the pressure and deaerate/drain lines.



WARNING!

Risk of injury from improper installation.

- ▶ Installation may be carried out by authorized technicians only and with the appropriate tools.

Risk of injury from unintentional activation of the system and an uncontrolled restart.

- ▶ Secure system from unintentional activation.
- ▶ Following installation, ensure a controlled restart.

Procedure:

- Connect the control medium to the pilot air port (1) (3 – 7 bar; instrument air, free of oil, water and dust).
- Attach the exhaust airline or a silencer to the exhaust air port (3) (see “Fig. 12: Pneumatic connection”).



Keep the adjacent supply pressure **always** at least 0.5 – 1 bar above the pressure which is required to move the actuator to its end position.



Important information for the problem-free functioning of the device:

- ▶ The installation must not cause back pressure to build up.
- ▶ Select a hose for the connection with an adequate cross-section.
- ▶ The exhaust air line must be designed in such a way that no water or other liquid can get into the device through the exhaust air port.

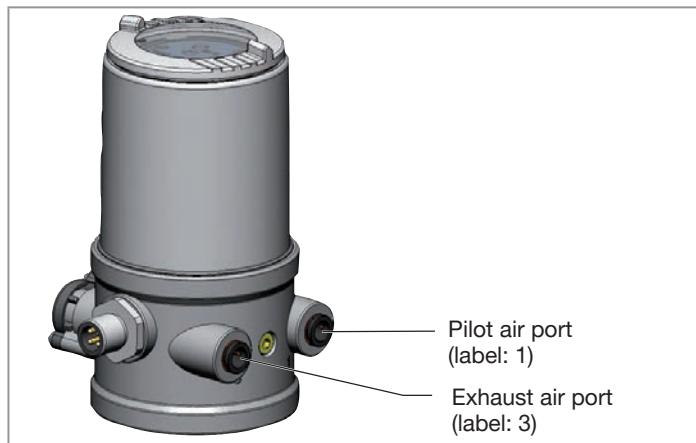

Fig. 12: Pneumatic connection



Exhaust air concept:

In compliance with protection class IP67, an exhaust air line must be installed in the dry area.

9 ELECTRICAL INSTALLATION

9.1 Safety instructions



DANGER!

Risk of electric shock.

- ▶ Before working on equipment or device, switch off the power supply and secure to prevent reactivation.
- ▶ Observe applicable accident prevention and safety regulations for electrical equipment.



WARNING!

Risk of injury from improper installation.

- ▶ Installation may be carried out by authorized technicians only and with the appropriate tools.

Risk of injury from unintentional activation of the system and an uncontrolled restart.

- ▶ Secure system from unintentional activation.
- ▶ Following installation, ensure a controlled restart.

Minimum temperature rating of the cable to be connected to the field wiring terminals: 75 °C

9.2 Electrical installation, without fieldbus communication

→ Connect the control head according to the table.

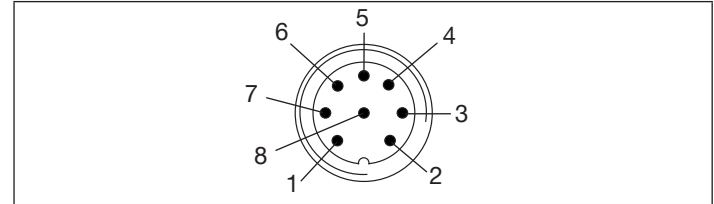

Fig. 13: Circular plug M12 x 1, 8-pin

Pin	Wire color ³⁾	Designation	Configuration
1	white	Digital output top position	DO 1 (=Top)
2	brown	Digital output bottom position	DO 2 (=Bot)
3	green	Operating voltage	GND
4	yellow	Operating voltage +	24 V DC
5	grey	Valve control +	Valve +
6	pink	Valve control -	Valve -
7		-	not used
8		-	not used

Tab. 2: Connection with circular plug-in connector

³⁾ The indicated colors refer to the connecting cable available as an accessory (919061)

9.3 Electrical installation, IO-Link Port Class B and Port Class A

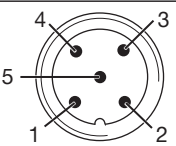
Port Class B	Pin	Designation	Configuration	
	1	L +	24 V DC	System supply
	2	P24	24 V DC	Actuator supply
	3	L -	0 V (GND)	System supply
	4	C/Q	IO-Link	
	5	M24	0 V (GND)	Actuator supply

Tab. 3: Pin assignment, Port Class B

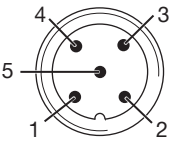
Port Class A	Pin	Designation	Configuration	
	1	L +	24 V DC	System supply
	2	Do not connect		
	3	L -	0 V (GND)	System supply
	4	C/Q	IO-Link	
	5	Do not connect		

Tab. 4: Pin assignment, Port Class A

9.4 Electrical installation, bUS

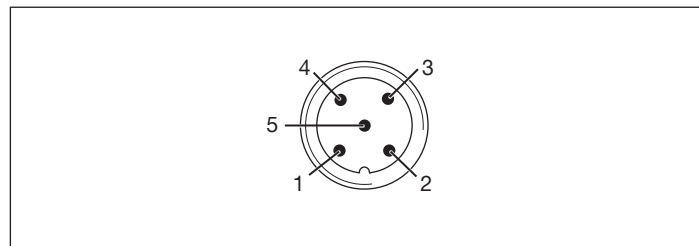

Fig. 14: Pin assignment

Pin	Wire color	Configuration
1	CAN plate/shielding	CAN plate/shielding
2	red	+24 V DC $\pm 25\%$, max. residual ripple 10 %
3	black	GND / CAN_GND
4	white	CAN_H
5	blue	CAN_L

Tab. 5: Pin assignment

! For electrical installation with bUS network, note:
Use a 5-pin round plug and shielded 5-core cable.
The shielding in the device is not connected to the functional earth.

10 CONTROL AND DISPLAY ELEMENTS



A detailed description of the operation and functions of the control head and communication software can be found in the respective operating instructions.

ATTENTION!

Breakage of the pneumatic connection pieces due to rotational impact.

- ▶ When unscrewing and screwing in the transparent cap, do not hold the actuator of the process valve but the basic housing.

→ Unscrew the transparent cap in a counter-clockwise direction.

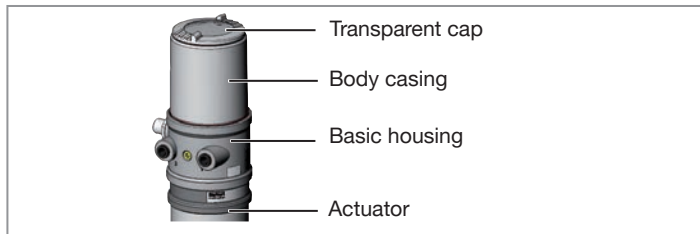

Fig. 15: Open and close the device

ATTENTION!

Damage or malfunction due to penetration of dirt and humidity.

- ▶ To observe protection class IP65/IP67, screw the transparent cap in all the way.

10.1 Operating state



To operate the buttons, make sure that the local control lock is deactivated/unlocked (factory setting): with communication software or fieldbus communication.

AUTOMATIC (AUTO)

Normal controller mode is implemented and monitored in AUTOMATIC operating state.

MANUAL (MANU)

In MANUAL operating state the valve can be opened and closed manually via the button 2.

The status LED flashes orange (function check, see [“10.3.3 NAMUR mode”](#)).

The buttons can be used to switch between the two operating states AUTOMATIC and MANUAL:

- Press both buttons simultaneously between 2 s and 10 s (com LED flashes 0 – 2 s at 5 Hz).

10.2 Configuration of the buttons



To operate the buttons, make sure that the local control lock is deactivated/unlocked (factory setting): with communication software or fieldbus communication.

The configuration of the 2 buttons varies depending on the operating state (AUTOMATIC / MANUAL).

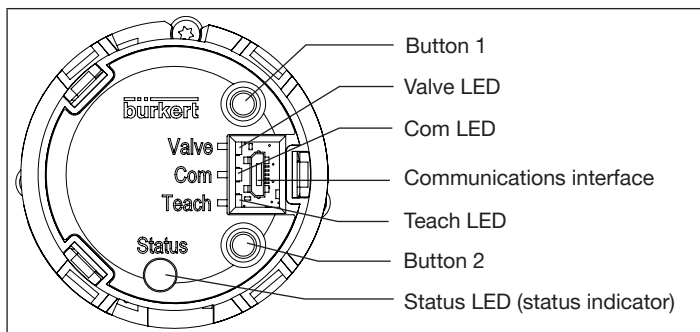

Fig. 16: Buttons

MANUAL operating state (status LED flashes orange, function check):

Button	Function/LED
1	-
2	Press briefly (Valve LED is lit yellow) Valve switches
1 and 2 simultaneously	Press longer than 2 s (< 10 s, Com LED flashes at 5 Hz (0 – 2 s)): Switching to AUTOMATIC operating state
	Press longer than 10 s (< 30 s, Valve LED, Com LED and Teach LED flash at 5 Hz (10 – 30 s)): Device restart
	Press longer than 30 s (Valve LED, Com LED and Teach LED flash at 10 Hz (> 30 s)): Reset device to factory setting

Tab. 6: Configuration of the buttons for MANUAL operating state

AUTOMATIC operating state (manual LED is not lit):

Button	Function/LED
1	Press longer than 5 s (< 10 s, Teach LED flashes at 5 Hz (5 – 10 s)): Starting the automatic teach function
	Press longer than 10 s (< 30 s, Teach LED flashes at 10 Hz, > 10 s): Starting the manual teach function
2	-
1 and 2 simultaneously	Press longer than 2 s (< 10 s, Com LED flashes at 5 Hz (0 – 2 s)): Switching to MANUAL operating state Status LED flashes orange
	Press longer than 10 s (< 30 s, Valve LED, Com LED and Teach LED flash at 5 Hz (10 – 30 s)): Device restart
	Press longer than 30 s (Valve LED, Com LED and Teach LED flash at 10 Hz (> 30 s)): Reset device to factory setting

Tab. 7: Configuration of the buttons for AUTOMATIC operating state

10.3 Display of the LEDs

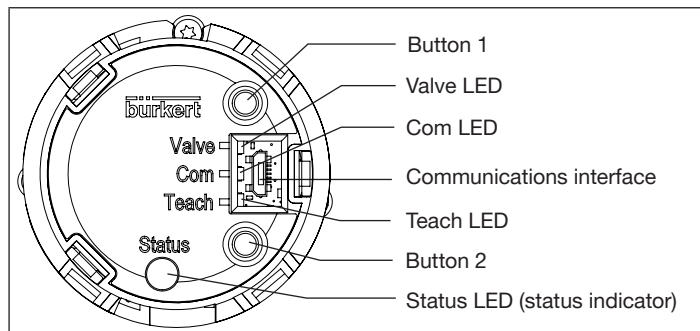

Fig. 17: Display elements

LED	State	
Com LED green	flashes	IO-Link communication active
Status LED RGB	see following chapters	Status indicator and valve position ⁴⁾
Valve LED yellow	is lit	Pilot valve is actuated
Teach LED red	is lit	Teach function error
	flashes	Teach function is running

Tab. 8: Display elements

⁴⁾ Factory setting.

10.3.1 Status indicator

The status LED (RGB) show the device status.

The user can set the following LED modes for the display of device status and valve position.

- Valve mode
- Valve mode with warnings (factory setting)
- NAMUR mode
- Fixed color
- LED off

The LED mode and the colors of the valve position can be set with the Bürkert Communicator.

IO-Link:

The LED mode and the colors of the valve position can be also set with an acyclic parameter (see parameter list).



The description for setting the LED mode can be found in the section "Setting the LED mode, status indicator" in the operating instruction.

10.3.2 Valve mode + warnings

Displays in valve mode + warnings:

- Valve position: open, half-way, closed
- Device status: failure, function check, out of specification, maintenance required (according to NAMUR)

Valve position		Device status
	Status, color	Normal operation
Open	is lit yellow*	--
Half-way	LED off*	--
Closed	is lit green*	--

Tab. 9: Valve mode + warnings, normal operation

If several device statuses exist simultaneously, the device status with the highest priority is displayed.

Valve position	Device status				
	Failure	Function check	Out of specification	Maintenance required	
	Status, color	Status, color	Status, color	Status, color	
Open	flashes red	flashes orange	flashes yellow	blinks blue	alternately with yellow*
Half-way	flashes red	flashes orange	flashes yellow	blinks blue	alternately with LED off*
Closed	flashes red	flashes orange	flashes yellow	flashes blue	alternately with green*

Tab. 10: Valve mode + warnings, device status

For warning messages, the LEDs are briefly switched off between the change of the colors.

For localizations, the colors are only shown momentarily.

10.3.3 NAMUR mode

The device status LED show the device status.

The display elements change color in accordance with NAMUR NE 107.

* Factory setting, selectable colors for the valve position: Off, white, green, blue, yellow, orange, red

* Factory setting, selectable colors for the valve position: Off, white, green, blue, yellow, orange, red

If several device statuses exist simultaneously, the device status with the highest priority is displayed. The priority is determined by the severity of the deviation from controlled operation (red LED = failure = highest priority).

Status display in accordance with NE 107, edition 2006-06-12			
Color	Color code	Status	Description
Red	5	Outage, error or malfunction	Normal operation is not possible due to a malfunction in the device or on its peripheral equipment.
Orange	4	Function check	Work is being carried out on the device; normal operation is therefore temporarily not possible
Yellow	3	Out of specification	Ambient conditions or process conditions for the device are outside the specified area.
Blue	2	Maintenance required	The device is in normal operation, although a function is briefly restricted. → Service device.
Green	1	Diagnostics active	Device is operating perfectly. Status changes are indicated in different colors. Messages are transmitted via a fieldbus if connected.

Tab. 11: Description of the colors

11 START-UP

11.1 Safety instructions



WARNING!

Risk of injury from improper operation.

Improper operation may result in injuries as well as damage to the device and the area around it.

- ▶ Before start-up, ensure that the operating personnel are familiar with and completely understand the contents of the operating instructions.
- ▶ Observe the safety instructions and intended use.
- ▶ Only adequately trained personnel may operate the equipment/the device.

11.2 Starting the automatic teach function (calibrating the end positions)

The teach function can be used to automatically determine and read in the end positions of the valve.



The description of the manual teach function can be found in the operating instructions.



With the IO-Link variant, the teach function can also be started with an acyclic IO-Link parameter (see parameter list) or with the Bürkert Communicator.

With the bus variant, the teach function can also be started with the Bürkert Communicator.

Essential requirements:

- The device is mounted on the actuator.
- The supply voltage is connected.
- The compressed air supply is connected.
- So that the correct reference conditions are identified, the pilot pressure must correspond to the operating conditions.

! DANGER!

Danger due to the valve position changing when the teach function is running.

When the teach function is running under operating pressure, there is an acute risk of injury.

- ▶ Never run the teach function while a process is running.
- ▶ Secure system from unintentional activation.

Procedure:

ATTENTION!

Breakage of the pneumatic connection pieces due to rotational impact.

- ▶ When unscrewing and screwing in the transparent cap, do not hold the actuator of the process valve but the connection housing.

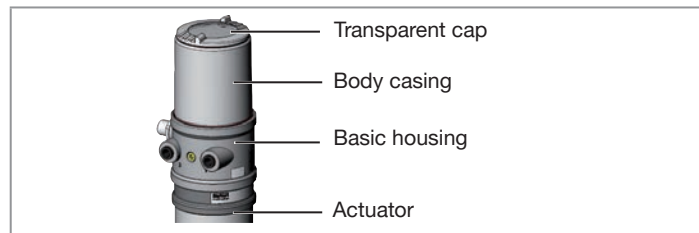

Fig. 18: Open device

- Open the device: turning the transparent cap anti-clockwise.
- Hold down the button 1 to start the teach function for approximately 5 seconds until the teach LED flashes.
- When the teach LED starts flashing, release the button within 5 seconds.
- ✔ When the teach LED stops flashing, the teach function is terminated.

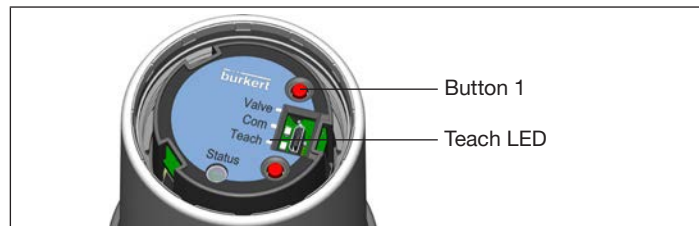

Fig. 19: Teach function

ATTENTION!

Damage or malfunction due to penetration of dirt and humidity.

- ▶ To observe protection class IP65 / IP67, screw the transparent cap in all the way.

→ Close the device (assembly tool: 674078⁵⁾).

Chronological description of the teach function:

- the bottom position is read in
- the pilot valve switches
- the actuator moves automatically to the top position
- the top position is read in
- the pilot valve is turned off
- the actuator moves back to the home position.

**Important:**

When the teach function is activated the actuator cannot be actuated via the communication interface.

⁵⁾ The assembly tool (674078) is available from your Bürkert sales office.

11.3 Setting with Bürkert Communicator

The Bürkert Communicator can be used to make all settings on the device.



The settings in the Bürkert Communicator can be found in the operating manual.

11.3.1 Connecting IO-Link device with Bürkert Communicator

To ensure clear communication, the IO-Link devices should not be parameterised simultaneously by the higher-level controller (PLC) via the IO-Link master and with the Bürkert Communicator (via the service).

Required components:

- Communications software: Bürkert Communicator for PC
- USB-büS interface set (see accessories)
- büS adapter for communication interface (see accessories)
- If necessary, a büS cable extension (see accessories)

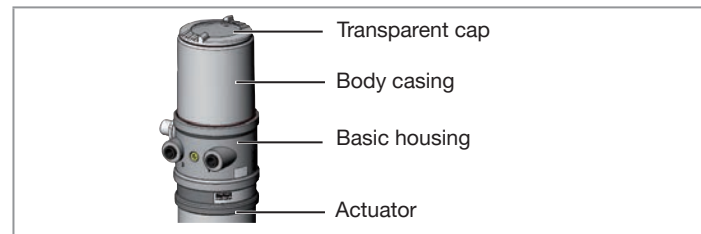

Fig. 20: Open device

ATTENTION

Breakage of the pneumatic connection pieces due to rotational impact.

- ▶ When opening or closing the device, do not press against the actuator, but against the basic housing.

→ Screw off the transparent cap by turning counterclockwise.

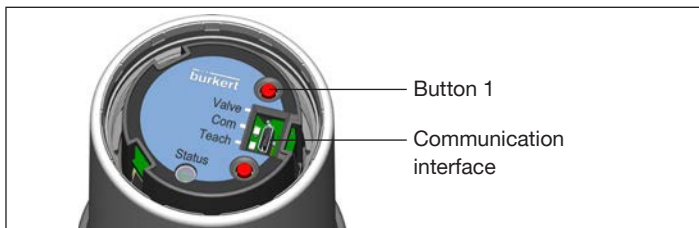

Fig. 21: Communication interface

- Insert micro USB plug in communication interface.
- Establish connection to PC with USB-büS interface set.
- Starting Bürkert Communicator.
- Implementing settings.

11.3.2 Connecting büS device with Bürkert Communicator

Required components:

- Communications software: Bürkert Communicator for PC
- USB-büS interface set (see accessories)

→ Establish connection to PC with USB-büS interface set.

→ Starting Bürkert Communicator.

→ Implementing settings.

11.4 IO-Link

11.4.1 Information, IO-Link

IO-Link is an internationally standardized IO technology (IEC 61131-9) to enable sensors and actuators to communicate.

IO-Link is a point-to-point communication with 3-wire connection technology for sensors and actuators and unshielded standard sensor cables.

To ensure clear communication, the IO-Link devices should not be parameterised simultaneously by the higher-level controller (PLC) via the IO-Link master and with the Bürkert Communicator (via the communication interface).

11.4.2 Technical specifications, IO-Link

Port Class	A	B
IO-Link Specification	V1.1.2	
Supply	via IO-Link (M12 x 1, 5-pin, A-coded)	
SIO mode	No	
IODD file	see Internet	
VendorID	0x0078, 120	
DeviceID	see IODD file	
ProductID	8695 Class A	8695 Class B
Transmission speed	COM3 (230,4 kbit/s)	

PD Input Bits	48
PD Output Bits	8
M-sequence Cap.	0x0D
Min. cycle time	5 ms
Data Storage	Yes
Max. cable length	20 m

11.4.3 Configuration of the fieldbus

The required start-up files and the description of the process data and acyclic parameters are available on the Internet.

Download from:
www.burkert.com / Type 8695 / Software

11.5 büS

11.5.1 Information, büS

büS is a system bus developed by Bürkert with a communication protocol based on CANopen.

11.5.2 Configuration of the fieldbus

The required start-up files and the description of objects are available on the Internet.

Download from:
www.burkert.com / Type 8695 / Software

12 SAFETY END POSITIONS

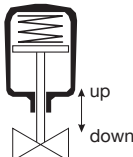
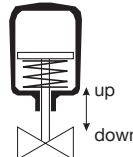
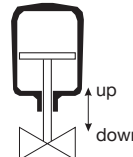
Actuator system	Designation	Safety end positions after failure of the auxiliary power	
		electrical	pneumatic
	single-acting Control function A	down	down
	single-acting Control function B	up	up
	double-acting Control function I	down	not defined

Tab. 12: Safety end positions

13 ACCESSORIES

Designation	Order no.
Connection cable M12 x 1, 8-pin	919061
Wrench for opening/closing the transparent cap	674078
Communication software Bürkert Communicator	Information at www.burkert.com

USB-büS interface set:	
USB-büS interface set (büS stick + 0.7 m cable with M12 plug)	772551
büS adapter for communication interface (M12 on büS service interface Micro-USB)	773254
büS cable extension (M12 pin to M12 socket), length 1 m	772404
büS cable extension (M12 pin to M12 socket), length 3 m	772405
büS cable extension (M12 pin to M12 socket), length 5 m	772406
büS cable extension (M12 pin to M12 socket), length 10 m	772407

Tab. 13: Accessories

13.1 Communications software

The PC operating program Bürkert Communicator is designed for communication with the devices Type 8695.

If you have any questions regarding compatibility, please contact the Bürkert Sales Center.



A detailed description and precise schedule of the procedure for the installation and operation of the software can be found in the associated documentation.

Download the software at: www.burkert.com

14 PACKAGING, TRANSPORT, STORAGE

ATTENTION!

Transport damages.

Inadequately protected equipment may be damaged during transport.

- ▶ During transportation protect the device against wet and dirt in shock-resistant packaging.
- ▶ Avoid exceeding or dropping below the permitted storage temperature.

Incorrect storage may damage the device.

- ▶ Store the device in a dry and dust-free location.
- ▶ Storage temperature -20 – +65 °C.

Damage to the environment caused by device components contaminated with media.

- ▶ Dispose of the device and packaging in an environmentally friendly manner.
- ▶ Observe applicable regulations on disposal and the environment.

www.burkert.com