

Type 8695

Control Head
Steuerkopf
Tête de commande



Quickstart

English Deutsch Français

We reserve the right to make technical changes without notice.
Technische Änderungen vorbehalten.
Sous réserve de modifications techniques.

© Bürkert Werke GmbH & Co. KG, 2007 - 2022

Quickstart 2206/09_EU-ML_00805384 / Original DE

1	QUICKSTART	4			
1.1	Definition of term / abbreviation	4			
1.2	Symbols.....	4			
2	AUTHORIZED USE	5			
3	BASIC SAFETY INSTRUCTIONS	5			
4	GENERAL INFORMATION	6			
4.1	Contact address.....	6			
4.2	Warranty	6			
4.3	Information on the internet	6			
5	SYSTEM DESCRIPTION	7			
5.1	Structure and function.....	7			
6	TECHNICAL DATA	8			
6.1	Conformity.....	8			
6.2	Standards	8			
6.3	Licenses	8			
6.4	Operating conditions	8			
6.5	Mechanical data	9			
6.6	Type labels.....	9			
6.7	Pneumatic data	10			
6.8	Electrical data.....	10			
7	INSTALLATION	11			
7.1	Safety instructions.....	11			
7.2	Installation of the control head on process valves of series 21xx	12			
7.3	Installation of the control head on process valves of series 20xx	13			
7.4	Manual actuation of the actuator via pilot valve.....	15			
8	PNEUMATIC INSTALLATION	16			
9	ELECTRICAL INSTALLATION / DISPLAY ELEMENTS	17			
9.1	Safety instructions.....	17			
9.2	Electrical installation 24 V DC	17			
9.3	Display elements 24 V DC.....	18			
9.4	Electrical installation AS-Interface	19			
9.5	Programming data.....	20			
9.6	Display elements AS-Interface	20			
10	TEACH FUNCTION	21			
10.1	Starting the teach function (calibrating the end position).....	21			
11	SAFETY POSITIONS	23			
12	ACCESSORIES	23			
13	PACKAGING, TRANSPORT, STORAGE	24			

1 QUICKSTART

The Quickstart describe the entire life cycle of the device. Keep the Quickstart in a location which is easily accessible to every user and make the Quickstart available to every new owner of the device.

Important Safety Information.

Read Quickstart carefully and thoroughly. Study in particular the chapters entitled “[Basic safety instructions](#)” and “[Authorized use](#)”.

- ▶ Quickstart must be read and understood.

Quickstart explains, for example, how to install and start-up the device.

A detailed description of the device can be found in the operating instructions for control head Type 8695.



The operating instructions can be found on the Internet at:
www.burkert.com

1.1 Definition of term / abbreviation

The term “device” used in these instructions always stands for the control head Type 8695.

In these instructions, the abbreviation “Ex” always refers to “potentially explosive atmosphere”.

1.2 Symbols

The following symbols are used in these instructions.



DANGER!

Warns of an immediate danger.

- ▶ Failure to observe the warning may result in a fatal or serious injury.



WARNING!

Warns of a potentially dangerous situation.

- ▶ Failure to observe the warning may result in serious injuries or death.



CAUTION!

Warns of a possible danger.

- ▶ Failure to observe this warning may result in a medium or minor injury.

NOTE!

Warns of damage to property.



indicates important additional information, tips and recommendations.



refers to information in these operating instructions or in other documentation.

- ▶ Designates an instruction to prevent risks.

→ designates a procedure that must be carried out.

2 AUTHORIZED USE

Non-authorized use of the control head Type 8695 may be a hazard to people, nearby equipment and the environment.

The device is designed to be mounted on pneumatic actuators of process valves for the control of media.

- ▶ In the potentially explosive atmosphere the control head Type 8695 may be used only according to the specification on the separate approval sticker. For use observe the additional instructions enclosed with the device together with safety instructions for the potentially explosive atmosphere.
- ▶ Devices without a separate approval sticker may not be used in a potentially explosive atmosphere.
- ▶ Do not expose the device to direct sunlight.
- ▶ Use according to the authorized data, operating conditions and conditions of use specified in the contract documents and operating instructions. These are described in the chapter entitled [“6 Technical data”](#).
- ▶ The device may be used only in conjunction with third-party devices and components recommended and authorized by Bürkert.
- ▶ In view of the large number of options for use, before installation, it is essential to study and if necessary to test whether the control head is suitable for the actual use planned.
- ▶ Correct transportation, correct storage and installation and careful use and maintenance are essential for reliable and faultless operation.
- ▶ Use the control head Type 8695 only as intended.

3 BASIC SAFETY INSTRUCTIONS

These safety instructions do not make allowance for any

- contingencies and events which may arise during the installation, operation and maintenance of the devices.
- local safety regulations – the operator is responsible for observing these regulations, also with reference to the installation personnel.



Risk of injury from high pressure in the equipment/device.

- ▶ Before working on equipment or device, switch off the pressure and deaerate/drain lines.

Risk of electric shock.

- ▶ Before working on equipment or device, switch off the power supply and secure to prevent reactivation.
- ▶ Observe applicable accident prevention and safety regulations for electrical equipment.

General hazardous situations.

To prevent injury, ensure:

- ▶ Installation and repair work may be carried out by authorized technicians only and with the appropriate tools.
- ▶ After an interruption in the power supply or pneumatic supply, ensure that the process is restarted in a defined or controlled manner.
- ▶ The device may be operated only when in perfect condition and in consideration of the operating instructions.
- ▶ The general rules of technology apply to application planning and operation of the device.

To prevent damage to property on the device, ensure:

- ▶ Do not feed any aggressive or flammable media into the pilot air port.
- ▶ Do not feed any liquids into the pilot air port.
- ▶ When unscrewing and screwing in the body casing or the transparent cap, do not hold the actuator of the process valve but the connection housing of Type 8695.
- ▶ Do not put any loads on the body (e.g. by placing objects on it or standing on it).
- ▶ Do not make any external modifications to the device bodies. Do not paint the body parts or screws.

4 GENERAL INFORMATION

4.1 Contact address

Germany

Bürkert Fluid Control System
Sales Center
Chr.-Bürkert-Str. 13-17
D-74653 Ingelfingen
Tel. + 49 (0) 7940 - 10 91 111
Fax + 49 (0) 7940 - 10 91 448
E-mail: info@burkert.com

International

Contact addresses can be found on the final pages of the printed operating instructions.

And also on the Internet at:

www.burkert.com

4.2 Warranty

The warranty is only valid if the control head Type 8695 is used as intended in accordance with the specified application conditions.

4.3 Information on the internet

The operating instructions and data sheets for Type 8695 can be found on the internet at:

www.burkert.com

5 SYSTEM DESCRIPTION

5.1 Structure and function

The control head Type 8695 can control single or double-acting process valves.

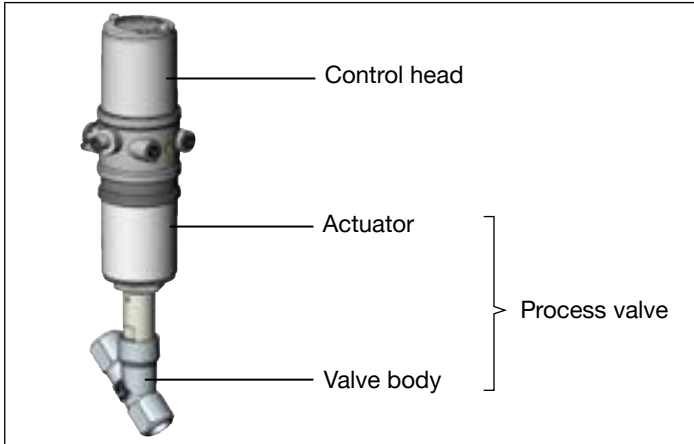

Fig. 1: Structure 1

Depending on the conditions of use, different process valves from the Bürkert range can be combined with the control head. Angle-seat valves, globe valves and diaphragm valves of series 21xx (Element) and 20xx (Classic) are suitable.

The control head Type 8695 has been optimized for the integrated modular fitting of series 21xx process valves (Element) with actuator size $\varnothing 50$. Various expansion stages are possible thanks to the modular design.

For installation on the 20xx series (Classic) there is a special model.

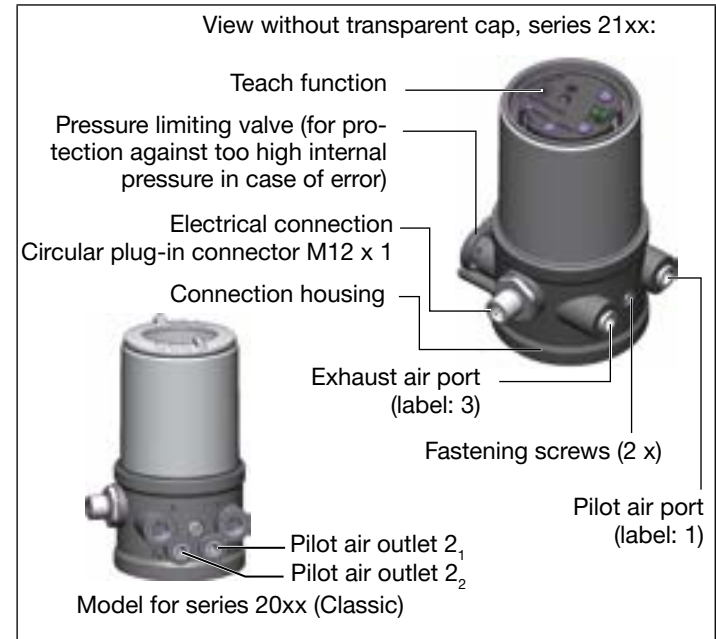

Fig. 2: Structure 2

6 TECHNICAL DATA

6.1 Conformity

In accordance with the EU Declaration of conformity, the control head Type 8695 is compliant with the EU Directives.

6.2 Standards

The applied standards on the basis of which compliance with the EU Directives is confirmed are listed in the EU type examination certificate and/or the EU Declaration of Conformity.

6.3 Licenses

The product is approved for use in zone 2 and 22 in accordance with ATEX directive 2014/34/EU category 3GD.



Observe instructions on operation in an potentially explosive atmosphere (Ex) area. Observe the ATEX additional instructions.

The product is cULus approved. Instructions for use in the UL area see chapter “[6.8 Electrical data](#)”.

6.4 Operating conditions



WARNING!

Solar radiation and temperature fluctuations may cause malfunctions or leaks.

- ▶ If the device is used outdoors, do not expose it unprotected to the weather conditions.
- ▶ Ensure that the permitted ambient temperature does not exceed the maximum value or drop below the minimum value.

Ambient temperature see type label

Degree of protection

Evaluated by the manufacturer:	Evaluated by UL:
IP65 / IP67 according to EN 60529 ¹⁾	UL Type 4x Rating indoor only ¹⁾

Operating altitude up to 2000 m above sea level

Relative air humidity max. 90% at 55 °C / 60 °C
(non condensing)

1) *Only if cables, plugs and sockets have been connected correctly and in compliance with the exhaust air concept see chapter “[8 Pneumatic installation](#)”.*

6.5 Mechanical data

Dimensions	See data sheet	
Body material	exterior	PPS, PC, VA
	interior	PA6; ABS
Sealing material	exterior	EPDM / FKM
Stroke range of valve spindle		
21xx series (Element) and 20xx series (Classic)	AS-Interface 2	– 25 mm
	24 V DC	2 – 35 mm
Third-party devices (modified guide element required)	AS-Interface 2	– 34 mm
	24 V DC	2 – 44 mm

6.6 Type labels

6.6.1 Type label standard (example)

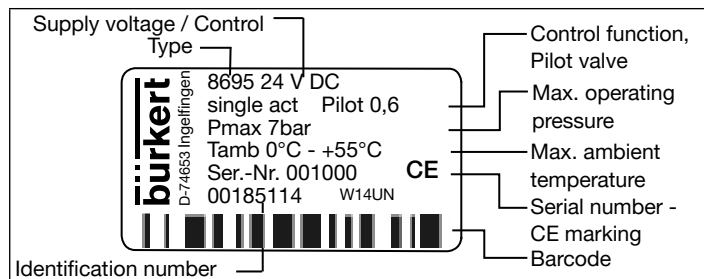

Fig. 3: Type label (example)

6.6.2 UL type label (example)

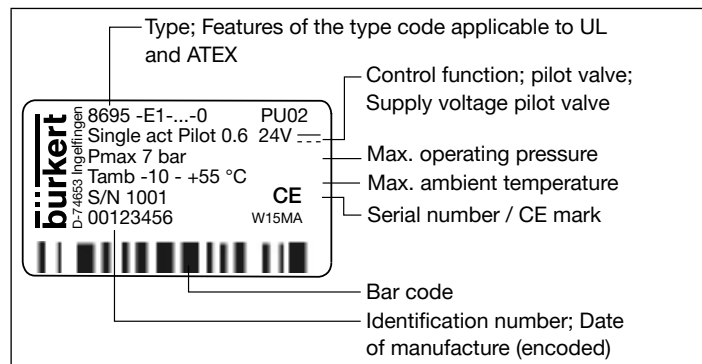

Fig. 4: UL type label (example)

6.6.3 UL additional label (example)

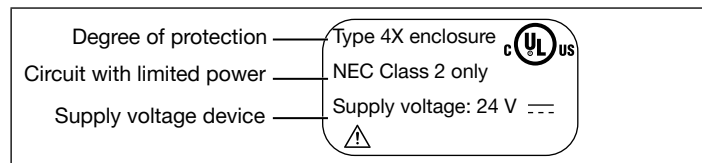

Fig. 5: UL additional label (example)

6.7 Pneumatic data

Control medium	neutral gases, air
	Quality classes in accordance with ISO 8573-1
Dust content	Class 7 max. particle size 40 µm, max. particle density 10 mg/m ³
Water content	Class 3 max. pressure dew point - 20 °C or min. 10 °C below the lowest operating temperature
Oil content	Class X max. 25 mg/m ³
Temperature range	-10 – +50 °C
Pressure range	3 – 7 bar
Air output of pilot valve	7 l _N / min (for aeration and deaeration) (Q _{Nn} - value according to definition for pressure drop from 7 to 6 bar absolute)
Connections	21xx (Element) Plug-in hose connector Ø 6 mm / 1/4" Socket connection G 1/8
	20xx (Classic) Socket connection G 1/8 with M5 connection for connecting to the actuator

6.8 Electrical data



WARNING!

Only circuits with limited power may be used for UL approved components according to “NEC Class 2”.

6.8.1 Electrical data without bus control 24 V DC

Protection class	III as per DIN EN 61140 (VDE 0140-1)
Connections	Circular plug-in connector (M12 x 1, 8-pin)
Pilot valve	
Supply voltage	24 V DC ± 10% - max. residual ripple 10 %
Power input	max. 1 W
Output	max. 100 mA per output
Display	max. 20 mA per illustrated illuminated display (LED)

6.8.2 Electrical data with AS-Interface bus control

Protection class	III as per DIN EN 61140 (VDE 0140-1)
Connections	Circular plug-in connector (M12 x 1, 4-pin)
Profile	S-B.A.E. (A/B slave, max. 62 slaves/ master)

Type 8695

Installation

Supply voltage 29.5 V – 31.6 V DC (according to specification)

Outputs

Max. switching capacity 1 W via AS-Interface
Watchdog function integrated

Max. power consumption 120 mA

Power consumption input during normal operation
(after current reduction;
valve +
1 end position reached) 90 mA

7 INSTALLATION



Only for control head without pre-assembled process valve.

7.1 Safety instructions



DANGER!

Risk of injury from high pressure in the equipment/device.

- ▶ Before working on equipment or device, switch off the pressure and deaerate/drain lines.

Risk of electric shock.

- ▶ Before working on equipment or device, switch off the power supply and secure to prevent reactivation.
- ▶ Observe applicable accident prevention and safety regulations for electrical equipment.



WARNING!

Risk of injury from improper installation.

- ▶ Installation may be carried out by authorized technicians only and with the appropriate tools.

Risk of injury from unintentional activation of the system and an uncontrolled restart.

- ▶ Secure system from unintentional activation.
- ▶ Following assembly, ensure a controlled restart.

7.2 Installation of the control head on process valves of series 21xx

NOTE!

When mounting on process valves with a welded body, follow the installation instructions in the operating instructions for the process valve.

! When the control head is being installed, the collets of the pilot air ports must not be fitted to the actuator.

NOTE!

Damaged printed circuit board or malfunction.

▶ Ensure that the puck is situated flat on the guide rail.

- Align the puck and the control head until
1. the puck can be inserted into the guide rail of the control head (see “Fig. 6”) and
 2. the connection pieces of the control head can be inserted into the pilot air ports of the actuator (see also “Fig. 7”).

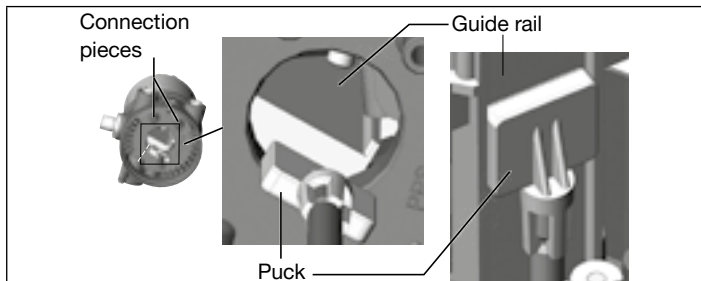

Fig. 6: Aligning the puck

- Push the control head, without turning it, onto the actuator until no gap is visible on the form seal.

NOTE!

Too high torque when screwing in the fastening screw does not ensure protection class IP65 / IP67.

▶ The fastening screws may be tightened to a maximum torque of 1.5 Nm only.

- Attach the control head to the actuator using the two side fastening screws. In doing so, tighten the screws only hand-tight (max. torque: 1.5 Nm).

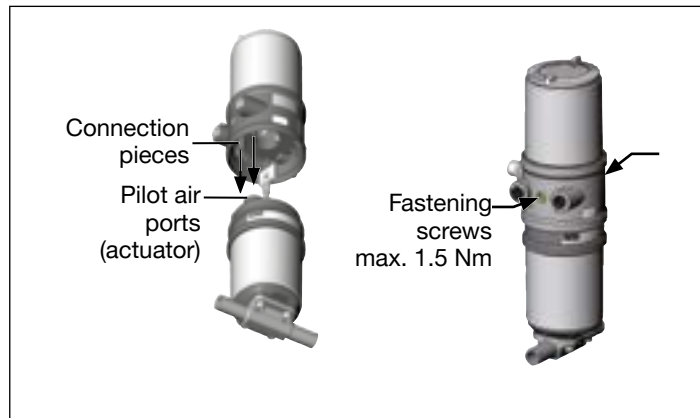

Fig. 7: Installation of control head, 21xx series

7.3 Installation of the control head on process valves of series 20xx

Procedure:

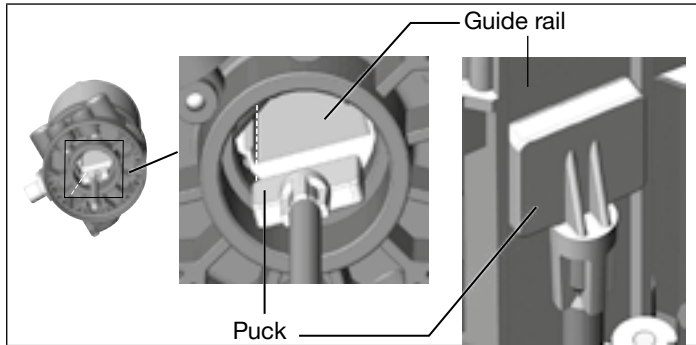

Fig. 8: Aligning the puck

NOTE!

Damaged printed circuit board or malfunction.

- ▶ Ensure that the puck is situated flat on the guide rail.

- Push the control head onto the actuator. The puck must be aligned in such a way that it is inserted into the guide rail of the control head (see "Fig. 8").
- Press the control head all the way down as far as the actuator and turn it into the required position.



Ensure that the pneumatic connections of the control head and those of the valve actuator are situated preferably vertically one above the other (see "Fig. 9").

NOTE!

Too high torque when screwing in the fastening screw does not ensure protection class IP65 / IP67.

- ▶ The fastening screws may be tightened to a maximum torque of 1.5 Nm only.

- Attach the control head to the actuator using the two side fastening screws. In doing so, tighten the fastening screws hand-tight only (maximum torque: 1.5 Nm).

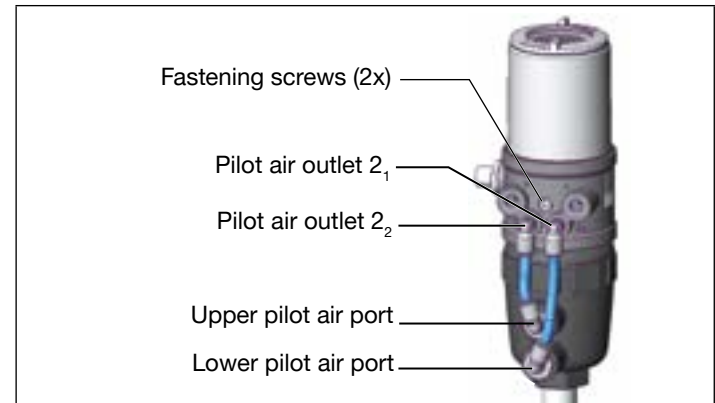

Fig. 9: Installing the pneumatic connection, 20xx series

- Screw the plug-in hose connectors onto the control head and the actuator.
- Using the hoses supplied in the accessory kit, make the pneumatic connection between the control head and actuator with the “Tab. 1: Pneumatic connection to actuator”.

NOTE!

Damage or malfunction due to ingress of dirt and moisture.

- ▶ To comply with protection class IP65 / IP67, connect the pilot air outlet (only for CFA or CFB) which is not required to the free pilot air port of the actuator or seal with a plug.



“In rest position” means that the pilot valves of the control head Type 8695 are isolated or not actuated.



If the ambient air is humid, a hose can be connected between pilot air outlet 2_2 of the control head and the unconnected pilot air port of the actuator for control function A or control function B. As a result, the spring chamber of the actuator is supplied with dry air from the vent duct of the control head.

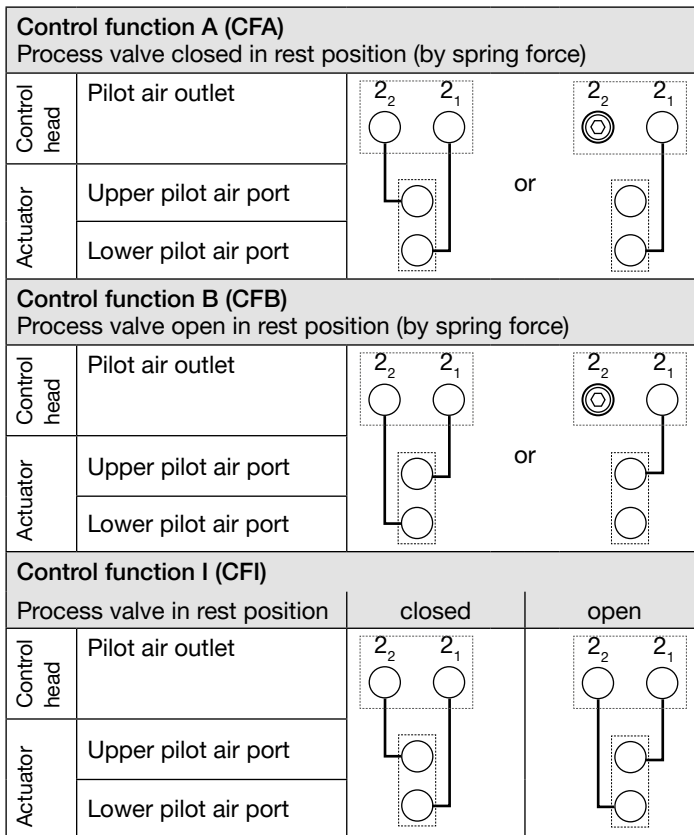

Tab. 1: Pneumatic connection to actuator

7.4 Manual actuation of the actuator via pilot valve

The actuator can be moved without a power supply from the rest position to its end position and back again, *when the control air is connected*.

To do this, the pilot valve must be actuated with a screwdriver.

NOTE!

The hand lever may be damaged if it is simultaneously pressed and turned.

- ▶ Do not press the hand lever when turning it.

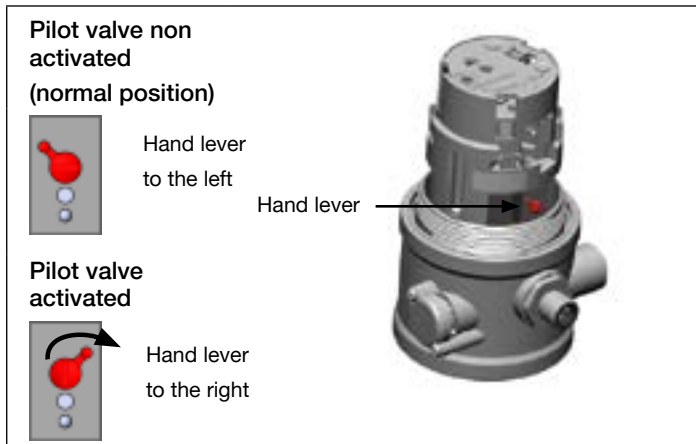

Fig. 10: Pilot valve for aerate and deaerate the actuator

Move actuator to end position

→ Turn the hand lever to the right using a screwdriver.

Note: Do not press the hand lever when turning it

Move actuator back to the rest position

→ Turn the hand lever to the left using a screwdriver.

Note: Do not press the hand lever when turning it

8 PNEUMATIC INSTALLATION



DANGER!

Risk of injury from high pressure in the equipment/device.

- ▶ Before working on equipment or device, switch off the pressure and deaerate/drain lines.



WARNING!

Risk of injury from improper installation.

- ▶ Installation may be carried out by authorized technicians only and with the appropriate tools.

Risk of injury from unintentional activation of the system and an uncontrolled restart.

- ▶ Secure system from unintentional activation.
- ▶ Following installation, ensure a controlled restart.

Procedure:

- Connect the control medium to the pilot air port (1)
(3 – 7 bar; instrument air, free of oil, water and dust).
- Attach the exhaust airline or a silencer to the exhaust air port (3)
(see “Fig. 11: Pneumatic connection”).



Keep the adjacent supply pressure **always** at least 0.5 – 1 bar above the pressure which is required to move the actuator to its end position.



Important information for the problem-free functioning of the device:

- ▶ The installation must not cause back pressure to build up.
- ▶ Select a hose for the connection with an adequate cross-section.
- ▶ The exhaust air line must be designed in such a way that no water or other liquid can get into the device through the exhaust air port.



Fig. 11: Pneumatic connection



Caution: (Exhaust air concept):

In compliance with protection class IP67, an exhaust air line must be installed in the dry area.

9 ELECTRICAL INSTALLATION / DISPLAY ELEMENTS

9.1 Safety instructions



DANGER!

Risk of electric shock.

- ▶ Before working on equipment or device, switch off the power supply and secure to prevent reactivation.
- ▶ Observe applicable accident prevention and safety regulations for electrical equipment.



WARNING!

Risk of injury from improper installation.

- ▶ Installation may be carried out by authorized technicians only and with the appropriate tools.

Risk of injury from unintentional activation of the system and an uncontrolled restart.

- ▶ Secure system from unintentional activation.
- ▶ Following installation, ensure a controlled restart.

Minimum temperature rating of the cable to be connected to the field wiring terminals: 75 °C

9.2 Electrical installation 24 V DC

→ Connect the control head according to the table.

The teach function can now be used to automatically determine and read in the end positions of the valve (description of the teach function see chapter [“10 Teach function”](#)).

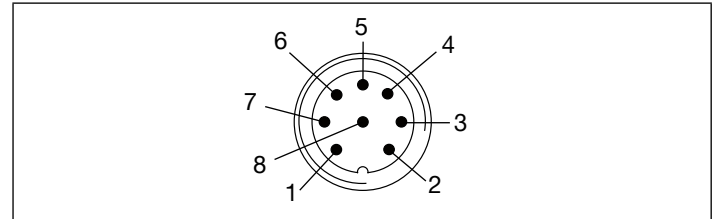

Fig. 12: Circular plug M12 x 1, 8-pole

Pin	Wire color ²⁾	Designation	Configuration
1	white	Limit switch top	IN 1 (=Top)
2	brown	Limit switch bottom	IN 2 (=Bot)
3	green	Supply voltage	GND
4	yellow	Supply voltage +	24 V DC
5	grey	Valve control unit +	Valve +
6	pink	Valve control unit -	Valve -
7		-	not used
8		-	not used

Tab. 2: Connection with circular plug-in connector

2) The indicated colors refer to the connecting cable available as an accessory (919061).

9.3 Display elements 24 V DC

NOTE!

Breakage of the pneumatic connection pieces due to rotational impact.

- ▶ When unscrewing and screwing in the transparent cap, do not hold the actuator of the process valve but the connection housing.

→ Unscrew the transparent cap in a counter-clockwise direction.

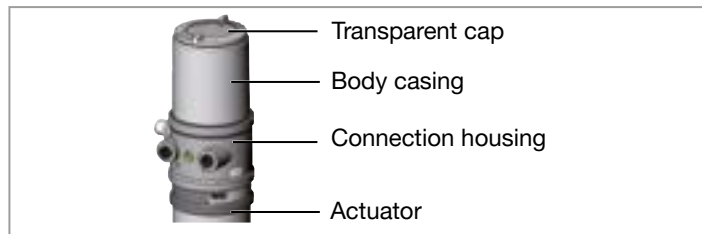

Fig. 13: Open control head

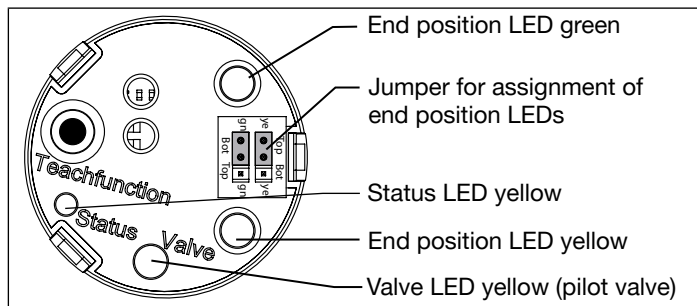

Fig. 14: Display elements 24 V DC

LED	State	
End position LED green	on	End position bottom ³⁾
End position LED yellow	on	End position top ³⁾
LED Valve yellow	on	Pilot valve is actuated
Status LED yellow	flashing	Teach function is running
	flickers	Puck PCB not available

Tab. 3: Display elements 24 V DC

NOTE!

Damage or malfunction due to penetration of dirt and humidity.

- ▶ To observe protection class IP65 / IP67, screw the transparent cap in all the way.

3) Color setting ex works. Can be set via jumper (see "Fig. 14").

9.4 Electrical installation AS-Interface

9.4.1 Connection with circular plug-in connector M12 x 1, 4-pole, male

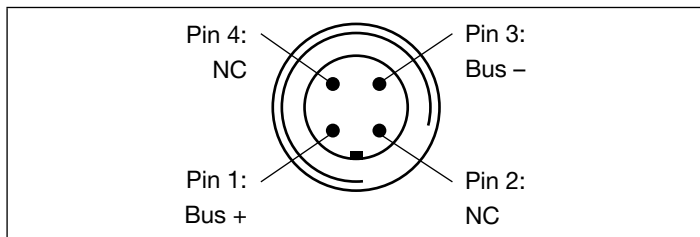

Fig. 15: Connection with circular plug-in connector, AS-Interface

Pin	Designation	Configuration
1	Bus +	AS-Interface bus line +
2	NC	not used
3	Bus -	AS-Interface bus line -
4	NC	not used

Tab. 4: Pin assignment of circular plug-in connector for AS-Interface

→ Connect the control head according to the table.

The teach function can now be used to automatically determine and read in the end positions of the valve (description of the teach function see chapter [“10 Teach function”](#)).



For the bus variant AS-Interface, the teach function can also be started via the bus protocol.

9.4.2 Connection with multi-pole cable and ribbon cable terminal

As an alternative to the bus connection model with 4-pole circular plug, there is the control head with multi-pole cable (M12 circular plug) and ribbon cable terminal. The wiring diagram of the circular plug corresponds to the bus connection of the M12 4-pole circular plug and can easily be connected to the ribbon cable terminal (see [“Fig. 16”](#)).

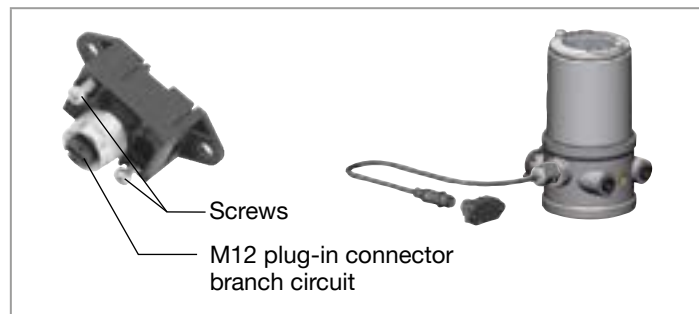

Fig. 16: Control head 8695 with multi-pole cable and ribbon cable terminal

Handling the ribbon cable terminal

The multi-pole cable features a ribbon cable terminal - with M12 plug-in connector branch circuit - for AS-Interface cable harness. The ribbon cable terminal contacts the AS-Interface cable harness by means of penetration technology which allows installation by “clipping in” the AS-Interface cable harness without cutting and without removing insulation.

Procedure:

- Open the ribbon cable terminal (loosen screws and remove cover)
- Insert cable harness conclusively
- Close ribbon cable terminal again
- Tighten screws
Slightly undo thread-forming screws (approx. 3/4 turn to the left) and position them on the existing tapped bore and screw in.

The teach function can now be used to automatically determine and read in the end positions of the valve (description of the teach function see chapter “10 Teach function”).



For the bus variant AS-Interface, the teach function can also be started via the bus protocol.

9.5 Programming data

I/O configuration	B hex
ID code	A hex
Extended ID code 1	7 hex
Extended ID code 2	E hex
Profile	S-B.A.E

Tab. 5: Programming data

9.6 Display elements AS-Interface

NOTE!

Breakage of the pneumatic connection pieces due to rotational impact.

- ▶ When unscrewing and screwing in the transparent cap, do not hold the actuator of the process valve but the connection housing (see “Fig. 13: Open control head”).

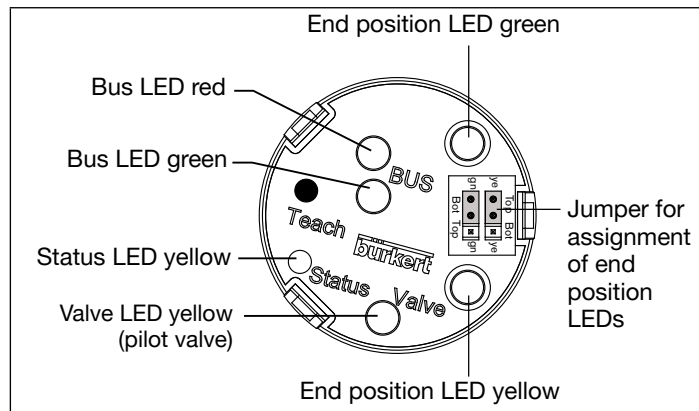

Fig. 17: Display Elements AS-Interface

NOTE!

Damage or malfunction due to penetration of dirt and humidity.

- ▶ To observe protection class IP65 / IP67, screw the transparent cap in all the way.

Bus LED (green)	Bus LED (red)	
off	off	POWER OFF
off	on	No data traffic (expired Watch Dog at slave address does not equal 0)
on	off	OK
flashing	on	Slave address equals 0
off	flashing	Sensor supply overloaded or external reset

Tab. 6: LED Status display bus status

LED	State	
Status LED yellow	flashing	Teach function is running
	flickers	Puck PCB not available
End position LED green	on	End position bottom ⁴⁾
End position LED yellow	on	End position top ⁴⁾
LED Valve yellow	on	Pilot valve is actuated

Tab. 7: Display elements AS-Interface

4) Color setting ex works. Can be set via jumper (see "Fig. 17").

10 TEACH FUNCTION

The teach function can be used to automatically determine and read in the end positions of the valve.



For the bus variant AS-Interface, the teach function can also be started via the bus protocol.

10.1 Starting the teach function (calibrating the end position)



Necessary requirements:

- Before you can actuate the teach function, you must
- mount the control head on the actuator,
 - connect the supply voltage and
 - connect the compressed-air supply.



DANGER!

Danger due to the valve position changing when the teach function is running.

When the teach function is running under operating pressure, there is an acute risk of injury.

- ▶ Never run the teach function while a process is running.
- ▶ Secure system from unintentional activation.

Procedure:

NOTE!

Breakage of the pneumatic connection pieces due to rotational impact.

- ▶ When unscrewing and screwing in the transparent cap, do not hold the actuator of the process valve but the connection housing.

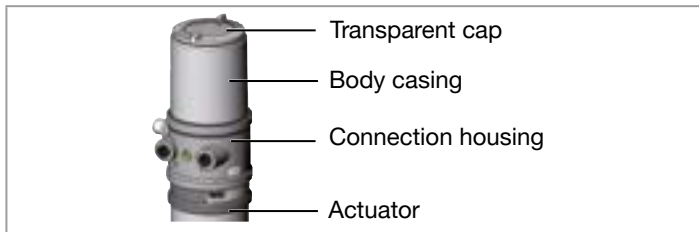

Fig. 18: Open control head

- Open the control head: turning the transparent cap anti-clockwise.
- The key in recess for actuating the teach function keep pressed for approximately 5 seconds.

NOTE!

Damage or malfunction due to penetration of dirt and humidity.

- ▶ To observe protection class IP65 / IP67, screw the transparent cap in all the way.

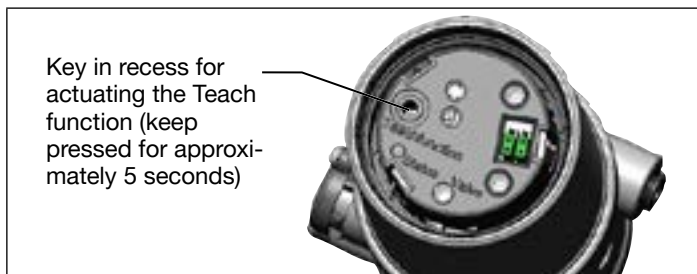

Fig. 19: Teach function

- Close the device (assembly tool: 674078⁵⁾).

Chronological description of the teach function:

- the bottom position is read in internally
- the pilot valve switches
- the actuator moves automatically to the top position
- the top position is read in internally
- the pilot valve is turned off
- the actuator moves back to the home position.



Important:

When the teach function is activated the actuator cannot be actuated via the communication interface.

⁵⁾ The assembly tool (674078) is available from your Bürkert sales office.

11 SAFETY POSITIONS

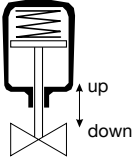
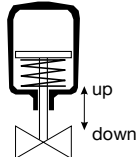
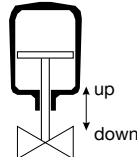
Actuator system	Designation	Safety positions after failure of the auxiliary power	
		electrical	pneumatic
	single-acting Control function A	down	down
	single-acting Control function B	up	up
	double-acting Control function I	down	not defined

Tab. 8: Safety positions

12 ACCESSORIES

Designation	Order no.
Connection cable M12 x 1, 8-pole	919061
Assembly tool	674078

Tab. 9: Accessories

13 PACKAGING, TRANSPORT, STORAGE

NOTE!

Transport damages.

Inadequately protected equipment may be damaged during transport.

- ▶ During transportation protect the device against wet and dirt in shock-resistant packaging.
- ▶ Avoid exceeding or dropping below the permitted storage temperature.

Incorrect storage may damage the device.

- ▶ Store the device in a dry and dust-free location.
- ▶ Storage temperature -20 – +65 °C.

Damage to the environment caused by device components contaminated with media.

- ▶ Dispose of the device and packaging in an environmentally friendly manner.
- ▶ Observe applicable regulations on disposal and the environment.

www.burkert.com