

Type 8643 Power I/O-Box

with PROFIBUS PA Profile 3.0 or FOUNDATION Fieldbus connection
mit PROFIBUS PA Profil 3.0 oder FOUNDATION Fieldbus-Anschaltung
avec PROFIBUS PA Profil 3.0 ou connexion FOUNDATION Fieldbus



Quickstart

English Deutsch Français

We reserve the right to make technical changes without notice.
Technische Änderungen vorbehalten.
Sous réserve de modifications techniques.

© Bürkert Werke GmbH & Co. KG, 2015 - 2017

Operating Instructions 1805/02_EU-EN_00806119 / Original DE

MAN 1000119250 ML Version: GStatus: RL (released | freigegeben) printed: 15.05.2018

1	QUICKSTART GUIDE	4	8	INSTALLATION	13
1.1	Definition of terms / Abbreviation	4	8.1	Safety instructions.....	13
2	SYMBOLS	4	8.2	Installation instructions.....	14
3	AUTHORIZED USE	5	8.3	Cable glands	14
3.1	Restrictions	5	8.4	Electrical Connections	15
3.2	Explosion protection approval	5	9	SETTING STATION ADDRESSES PROFIBUS PA	18
4	BASIC SAFETY INSTRUCTIONS	5	9.1	LED display.....	19
5	GENERAL INFORMATION	7	9.2	Watchdog	19
5.1	Contact address.....	7	10	NETWORK CONFIGURING PROFIBUS PA	19
5.2	Warranty	7	10.1	Storage allocation for user data transfer	19
5.3	Information on the Internet	7	10.2	System parameters	19
6	SYSTEM DESCRIPTION	8	11	START-UP	20
6.1	General description	8	11.1	Safety instructions.....	20
6.2	Application area.....	8	11.2	Start-up.....	20
7	TECHNICAL DATA	11	11.3	Shutdown	20
7.1	Conformity.....	11	11.4	Starting up the device again	21
7.2	Standards.....	11	12	MAINTENANCE	21
7.3	General technical data.....	11	13	TRANSPORTATION, STORAGE, DISPOSAL	21

1 QUICKSTART GUIDE

The quickstart guide contains the most important information and notes regarding the use of the device. A detailed description can be found in the operating instructions for Type 8643.

Keep the quickstart guide in a location which is easily accessible to every user and make it available to every new owner of the device.

Important Safety Information.

Read Quickstart carefully and thoroughly. Study in particular the chapters entitled *Basic safety instructions* and *Authorized use*.

- ▶ Quickstart must be read and understood.



The operating instructions can be found on the Internet at:

www.buerkert.de

1.1 Definition of terms / Abbreviation

In these instructions, the term "device" always refers to the Power I/O Box Type 8643.

2 SYMBOLS

The following symbols are used in these instructions.



DANGER!

Warns of an immediate danger.

- ▶ Failure to observe the warning will result in a fatal or serious injury.



WARNING!

Warns of a potentially dangerous situation.

- ▶ Failure to observe the warning may result in a serious or fatal injury.



CAUTION!

Warns of a possible danger.

- ▶ Failure to observe this warning may result in a moderate or minor injury.

NOTE!

Warns of damage to property.



Important tips and recommendations.



Refers to information in these operating instructions or in other documentation.

- ▶ indicates an instruction to prevent risks.

→ designates a procedure which you must carry out.

3 AUTHORIZED USE

Unauthorized use of the Power I/O Box Type 8643 can be dangerous to people, nearby equipment and the environment.

- ▶ The device is designed as a valve and sensor connection. Only sensors and valves may be connected which comply with the technical specifications.
- ▶ The device must not be used outside.
- ▶ Do not subject the housing of the Power I/O Box Type 8643 to mechanical loads (e.g. by placing objects on it or standing on it).
- ▶ During use observe the authorized data, the operating conditions and conditions of use specified in the contract documents and operating instructions, as indicated in the EC-Type Examination Certificate.
- ▶ The device may be used only in conjunction with third-party devices and components recommended and authorized by Bürkert.
- ▶ Correct transportation, correct storage and installation and careful use and maintenance are essential for reliable and faultless operation.
- ▶ Use the device only as intended.

3.1 Restrictions

If exporting the system/device, observe any existing restrictions.

3.2 Explosion protection approval

Any unauthorized changes to the Power I/O Box Type 8643 or to components invalidate the explosion protection approval.

4 BASIC SAFETY INSTRUCTIONS

These safety instructions do not make allowance for any

- contingencies and events which may arise during the installation, operation and maintenance of the devices.
- local safety regulations – the operator is responsible for observing these regulations, also with reference to the installation personnel.



Hazardous if used in explosion-risk area

Risk of explosion from electrical voltage.

The Power I/O Box Type 8643 is designed as ignition protection type Ex-e (increased safety).

- ▶ Before working on non-intrinsically safe circuits of the Power I/O Box Type 8643, always switch off the operating voltage of the system.

Danger of explosion due to internal charging of the Power I/O Box Type 8643.

When the power supply to the Power I/O Box Type 8643 is switched off, the internally stored charge will not be completely dissipated for 4 minutes.

To prevent an explosion, switch off the power supply before connecting or disconnecting Ex-e terminals.

- ▶ Do not remove the cover from the connection terminals for Ex-e switching circuits until the connected Ex-e circuits have been disconnected from the power supply for longer than 4 minutes.

Danger of explosion if the allowable ambient temperature ranges are exceeded.

- ▶ Observe the respective ambient temperature range which is based on the type designation (e.g. 8643-4-AL-KS-F-I/O), according to the table in the EC-Type Examination Certificate.

Danger of explosion due to unauthorized combination of the ignition protection types.

Due to unauthorized combination of the ignition protection types, the device is not suitable for use in the explosion-risk area. If the device is nevertheless used in this area, there is a danger of explosion.

- ▶ If the bus supply of the device was operated once in ignition protection type of increased safety (e), the bus supply may no longer be intrinsically safe in the ignition protection type (i).

General hazardous situations.

To prevent injury, ensure that:

- ▶ The system cannot be activated unintentionally.
- ▶ Installation and repair work may be carried out by authorized technicians only and with the appropriate tools.
- ▶ After an interruption in the power supply or pneumatic supply, ensure that the process is restarted in a defined or controlled manner.
- ▶ The device may be operated only when in perfect condition and in consideration of the operating instructions.
- ▶ The general rules of technology apply to application planning and operation of the device.

NOTE!

Electrostatic sensitive components / modules.

The device contains electronic components which react sensitively to electrostatic discharge (ESD). Contact with electrostatically charged persons or objects is hazardous to these components. In the worst case scenario, they will be destroyed immediately or will fail after start-up.

- ▶ Observe the requirements in accordance with EN 61340-5-1 to minimise or avoid the possibility of damage caused by sudden electrostatic discharge.
- ▶ Also ensure that you do not touch electronic components when the operating voltage is present.



The explosion protection approval is only valid if you use the Power I/O Box Type 8643 as indicated. If you make any unauthorized changes, the explosion protection approval will be invalidated.

Operate the Power I/O Box Type 8643 only when it is in perfect condition and in accordance with the operating instructions.

Information on the PROFIBUS PA



Detailed information on the start-up of a PROFIBUS PA line can be found in the *PROFIBUS PA User and Installation Guideline* at: www.profibus.de.

Information on the FOUNDATION Fieldbus



Detailed information on the start-up of a FOUNDATION Fieldbus line can be found in the *FOUNDATION Fieldbus Application Guide* at: www.fieldbus.org.

5 GENERAL INFORMATION

5.1 Contact address

Germany

Bürkert Fluid Control Systems
Sales Center
Christian-Bürkert-Str. 13-17
D-74653 Ingelfingen
Tel. + 49 (0) 7940 - 10 91 111
Fax + 49 (0) 7940 - 10 91 448
E-mail: info@de.buerkert.com

International

Contact addresses can be found on the final pages of the printed operating instructions.

And also on the internet at: www.burkert.com

5.2 Warranty

The warranty is only valid if the Power I/O Box Type 8643 is used as intended in accordance with the specified application conditions.

5.3 Information on the Internet

Operating instructions and data sheet for the Power I/O Box Type 8643 can be found on the Internet at:

www.burkert.com

6 SYSTEM DESCRIPTION

6.1 General description

The Power I/O Box Type 8643 with PROFIBUS PA or FOUNDATION Fieldbus connection is used to connect binary signals to the PROFIBUS PA or the FOUNDATION Fieldbus. It is suitable for use in areas where there is a risk of explosion, authorized according to ATEX for use in Zone 1 and 21.

The device is supplied for the Ex-i bus (FISCO) via a voltage source, as the usable energy from the bus line is severely restricted. In the case of the Power I/O Box Type 8643 with PROFIBUS PA interface connection the connection to an Ex-e bus is also possible.

Power I/O Box Type 8643 with PROFIBUS PA interface connection

The device is available in an aluminum or polyester housing belonging to degree of protection IP65.

Power I/O Box Type 8643 with FOUNDATION Fieldbus interface connection

The device is available either in an aluminum or polyester housing belonging to degree of protection IP65 or as an electronic module in IP20/IP30 for installation in a housing with Ex approval or in control cabinets.

6.2 Application area

The device is designed for remote use in an industrial environment, particularly in the areas of the pharmaceutical industry, petrochemistry and fine chemistry.



DANGER!

Risk of explosion from electrical voltage.

The device is designed as ignition protection type Ex-e (increased safety).

- ▶ Before working on non-intrinsically safe circuits of the device, always switch off the operating voltage of the system.



If using the device in a control cabinet, ensure that

- the control cabinet is also authorized for use in an environment where there is a risk of explosion,
- the control cabinet is large enough for the lost heat to be discharged to the exterior in a suitable manner,
- the internal temperature of the control cabinet does not exceed the allowable operating temperature of the device.

Type 8643

System description

6.2.1 Cable connections on the housing

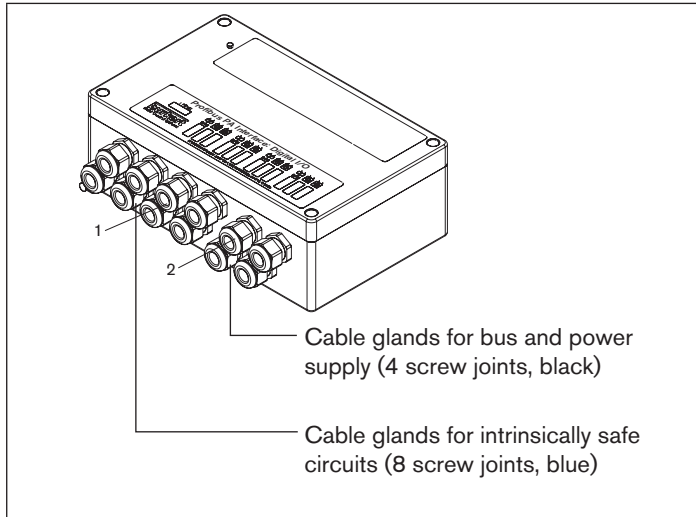

Fig. 1: Location of the cable connections on the aluminium housing of the device

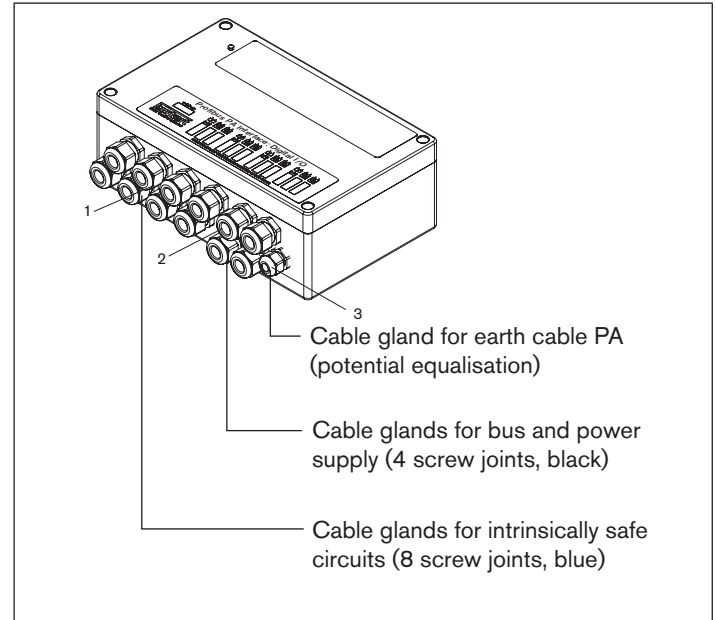
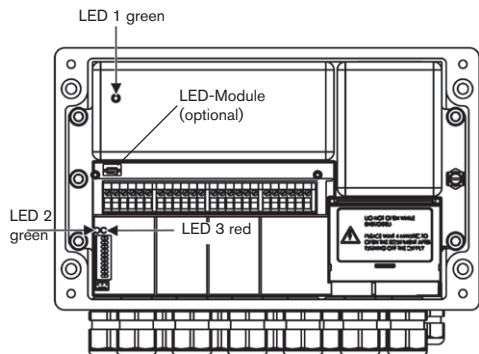

Fig. 2: Location of the cable connections on the plastic housing of the device



When delivered, the cable glands are covered with protective caps. These protective caps must remain on the cable glands until the cables are connected to keep out dirt.

LED display



- LED 1 is lit when voltage is applied to the bus supply.
- LED 2 is lit if the device is using cyclic data transfer.
- LED 3 is lit if the device is not using cyclic data transfer (only after Power on or if the Watchdog is active).

Fig. 3: Location of the LED display



If neither LED 2 nor LED 3 is lit, check power supply.

6.2.2 DIP switches (only Power I/O Box Type 8643 with FOUNDATION Fieldbus interface connection)

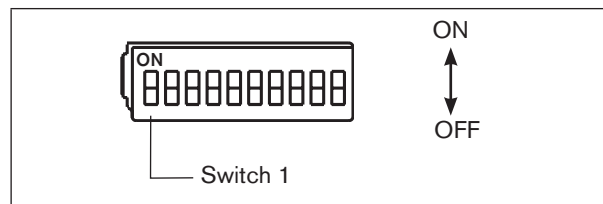

Fig. 4: DIP switches

Switch 1 - ON:

Simulate can be locked to overwrite the READBACK_D in the DO_valve function block.

7 TECHNICAL DATA

7.1 Conformity

Type 8643 conforms with the EC Directives according to the EC Declaration of Conformity (if applicable).

7.2 Standards

The applied standards, which verify conformity with the EC Directives, can be found on the EC-Type Examination Certificate and / or the EC Declaration of Conformity (if applicable).

7.3 General technical data

Housing material	Polyester, aluminum
Cable entry	Polyamide cable glands
Degree of protection	IP65 (DIN EN 60529)
IP65 (DIN EN 60529)	3 (DIN EN 61140(VDE 0140-1))
Ambient temperature	-20 ... +60 °C
Ignition protection identification (complete device)	
ATEX	II 2 (1) G Ex e mb [ia IIC Ga] IIC T4 Gb II 2 (1) D Ex tb [ia IIIC Da] IIIC T65 °C Db IP65 (with appropriately certified housing)
IECEX	Ex e mb [ia IIC Ga] IIC T4 Gb Ex tb [ia IIIC Da] IIIC T65 °C Db IP65 (with appropriately certified housing)

Inputs and Outputs	
Inputs	8, intrinsically safe, NAMUR (in accordance with EN 60947-5-6)
Outputs	4, intrinsically safe, outputs for pilot valves
min. switching current	30 mA (power reduction on holding current after 50 ms)
min. holding current	15 mA
Internal resistance	280 ... 330 Ω
No-load voltage	24 V
Electrical connections	screw terminals (up to 2.5 mm ²)
Power supply voltage	
Auxiliary voltage 24 V	17 ... 32 V DC
max. power requirement	200 mA (17 V) 140 mA (24 V) 110 mA (32 V)
Bus voltage	9 ... 32 V DC
Power input bus	12 mA / 17 mA FDE
Fieldbus interface (communication in accordance with IEC 1158-2)	
Communication	according to FISCO
Ignition protection type	EEx i

Electrical connection	4 screw terminals bus (up to 2.5 mm ²) 3 screw terminals shield (1x directly grounded, 2x capacitively grounded)
Auxiliary supply	
Ignition protection type	Increased safety EEX e
Electrical connection	4 screw terminals (up to 2.5 mm ²)
Device key (see rating plate)	
Polyester housing	8643-4-PO-XX-X-XXX
Aluminum housing	8643-4-AL-XX-X-XXX

- ! The cable resistance to the sensors and actuators may be max. 20 Ω.
- The Power I/O Box Type 8643 may be supplied with low safety voltage in accordance with VDE 0631 only.

- 📖 The Power I/O Box Type 8643 satisfies the conditions of the EMC Law. EN61000-6-2 Interference Resistance, EN61000-6-4 Interference Emission.
- The safety-related maximum values for operation in the explosion-risk area can be found in the Type Examination Certificate.

7.3.1 Dimensions

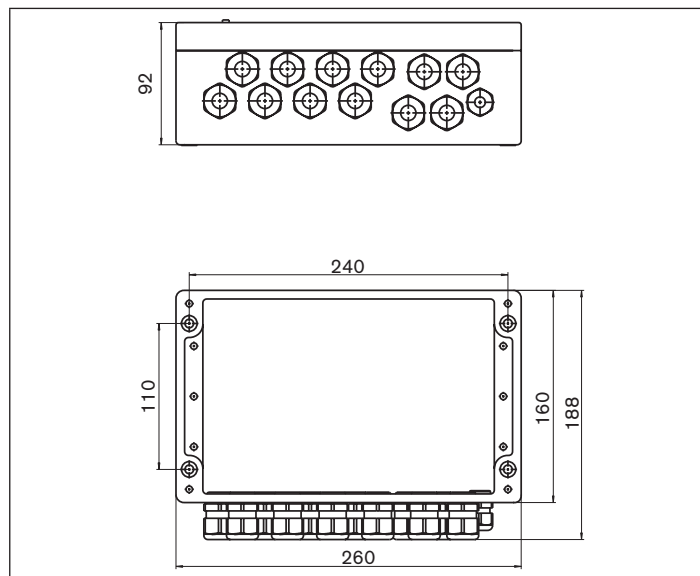

Fig. 5: Dimensions Type 8643

8 INSTALLATION

8.1 Safety instructions



DANGER!

Hazardous if used in explosion-risk area.

Risk of explosion from electrical voltage.

The Power I/O Box Type 8643 is designed as ignition protection type Ex-e (increased safety).

- ▶ Before working on non-intrinsically safe circuits of the Power I/O Box Type 8643, always switch off the operating voltage of the system.

Risk of explosion due to internal charging.

When the power supply to the Power I/O Box Type 8643 is switched off, the internally stored charge will not be completely dissipated for 4 minutes. To prevent an explosion, switch off the power supply before connecting or disconnecting Ex-e terminals.

- ▶ Do not remove the cover from the connection terminals for Ex-e switching circuits until the connected Ex-e circuits have been disconnected from the power supply for longer than 4 minutes.

Risk of explosion if the allowable ambient temperature ranges are exceeded.

- ▶ Observe the respective ambient temperature range which is based on the type designation (e.g. 8643-4-AL-KS-F-I/O), according to the table in the EC-Type Examination Certificate.

Risk of explosion due to unauthorized combination of the ignition protection types.

Due to unauthorized combination of the ignition protection types, the device is not suitable for use in the explosion-protected area. If the device is nevertheless used in this area, there is a risk of explosion.

- ▶ If the bus supply of the device was operated once in ignition protection type of *increased safety (e)*, the bus supply may no longer be *intrinsically (i)* safe in the ignition protection type.



WARNING!

Risk of injury due to improper assembly.

- ▶ Assembly may only be carried out by authorized specialist personnel and using the appropriate tools.
- ▶ Observe the national regulations which apply to the installation/operation of electrical equipment in areas where there is a risk of explosions.



WARNING!

Risk of injury from unintentional activation of the system and uncontrolled restart.

- ▶ Secure system against unintentional activation.
- ▶ Following assembly, ensure a controlled restart.

NOTE!

Electrostatic sensitive components / modules.

The Power I/O Box Type 8643 contains electronic components which respond sensitively to electrostatic discharge (ESD).

Contact with electrostatically charged persons or objects is hazardous to these components. In the worst case scenario, they will be destroyed immediately or will fail after start-up.

- ▶ Observe the requirements in accordance with EN 100 015 - 1 to minimize or avoid the possibility of damage caused by a sudden electrostatic discharge.
- ▶ Do not touch the electronic components while the power supply voltage is on.

NOTE!

Function restriction

The function of the device may be restricted without potential equalization.

- ▶ Connect the earth terminal point on the housing to the potential equalization (PA).

8.2 Installation instructions

NOTE!

- ▶ Do not exceed the permitted technical data.
- ▶ Preferred installation position:
Cable glands point downwards.

- ▶ The cable glands on the housing have a metric thread.
- ▶ Use only shielded lines for the bus supply.
- ▶ Place the shields of the bus line on the designated screw terminals as short as possible.
- ▶ When work is complete, the housing must be carefully sealed again.



This device complies with the EMC Directive of the Council of the European Union No. 2004/108/EC.
Follow the installation instructions to satisfy the conditions of this directive.

8.3 Cable glands



WARNING!

Risk of explosion.

No explosion protection if cable glands are defective or wrong.

- ▶ Replace defective cable glands only with Ex-approved (Ex e II) cable glands with adequate application temperature range (Type Examination Certificate).



At the factory all cable glands are sealed with a plug (degree of protection IP65).

- ▶ Seal all unused cable glands with a plug to maintain IP protection (IP65).

Type 8643

Installation

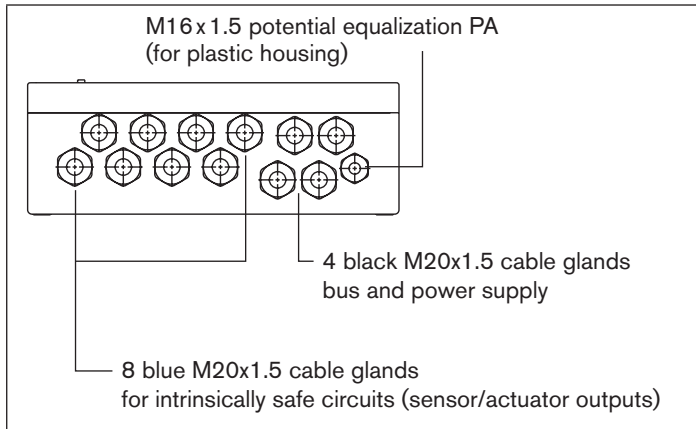

Fig. 6: Cable glands on the metal housing

The housing features eight blue cable glands for the intrinsically safe circuits and four black glands for the bus and power supply with increased safety.

The bus and power supplies each have two M20 x 1.5 glands to loop through the supply lines.

For sensors and actuators each output (with two sensors) has an M20 x 1.5 cable gland.

! Devices with plastic housing have an M16 x 1.5 cable gland for the internal ground connection (PA). Devices with metal housing (e.g. aluminum) have a ground connection on the outside of the housing.

8.4 Electrical Connections

8.4.1 Safety instructions

NOTE!

No function if reverse polarity.

► Pay attention to the polarity of the terminals.

The device is protected against polarity reversal.

8.4.2 Overview of the terminals and outputs

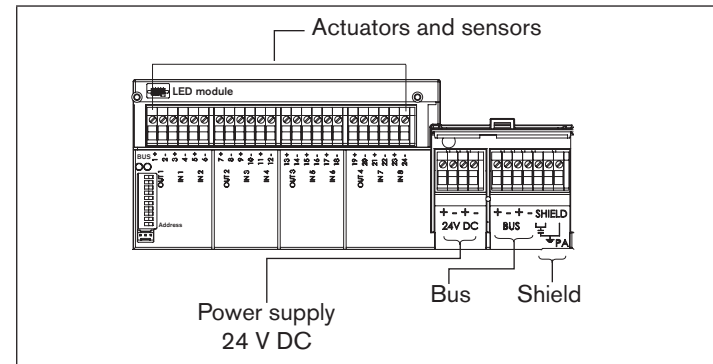

Fig. 7: Overview of terminals and outputs

8.4.3 Supply connection

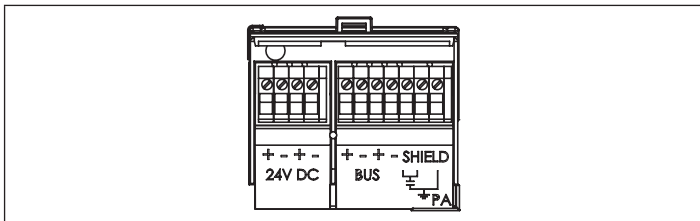

Fig. 8: Supply connection

24 V DC terminal

Connection for the power supply in the ignition protection type EEx e II. Max. connected loads see EC Type Examination Certificate.

Bus terminal

Connection for the bus supply in accordance with IEC 1158-2.

There are two options available depending on the device model:

- **Bus supply with increased safety**
Ignition protection type: EEx e II
- **Intrinsically safe bus supply**
Ignition protection type: EEx ia IIC or ignition protection type EEx ia IIB



DANGER!

Risk of explosion due to unauthorized combination of the ignition protection types.

Unauthorized combination of the ignition protection types may cause hazardous situations.

- ▶ If the bus supply of the device was operated once in ignition protection type of *increased safety (e)*, the bus supply may no longer be *intrinsically (i)* safe in the ignition protection type.

8.4.4 Connection of the SHIELD terminal

Connection for the cable shield of the bus line.

There are two options available for connection of the cable shield.

- **Direct earthing to the housing (PA)**

Connection of the cable shield:

→ Connect cable shield to the right terminal.

- **Capacitive earthing to the housing (PA)**

To discharge EMC interference to the earth potential, a capacitor with a capacity < 10 nF is installed in the device.

If several devices are connected in parallel with capacitive shield earthing, the energy stored in the capacitors in the event of a fault must not exceed the authorized limit values (see IEC/EN 60079-11) of the valid gas group. To determine the stored energy, the maximum authorized bus voltage must be taken into consideration.

Type 8643

Installation

Connection of the cable shield:

- Connect cable shield to the two left terminals.
- Connect the shield in a continuous manner.
- Earth the shield at a point in the bus line.



The terminals for the bus and power supply have a cover to protect against unintentional contact.

Housing terminals

Connection for the potential equalization (PA).

Electromagnetic compatibility

To ensure an adequate discharge of EMC interference, connect the earth terminal to the potential equalization (PA) via a shortest possible line. If this is not possible, use suitable measures to prevent electromagnetic interference from unduly influencing the Power I/O Box Type 8643.

Connection cable:

- minimum cross-section: 2.5 mm²
- maximum length: 0.5 m



To ensure that the housing is not leaking, the outer diameter of the connection cable must be min. 4 mm for the plastic housing.

8.4.5 ACTUATOR terminals

The Power I/O Box Type 8643 has power-reduced outputs. This means that the current required to activate the actuator is provided at the switching moment and reduced to the holding current after a specified time.

The actuator outputs are designed as ignition protection type ia.

	Terminal designation	
Polarity	+	-
Output 1	1	2
Output 2	7	8
Output 3	13	14
Output 4	19	20

8.4.6 SENSOR terminals

The Power I/O Box Type 8643 has eight NAMUR sensor inputs; two sensors are always assigned to one actuator output.

The sensors signal back the end positions of a connected process valve. However, they can also signal back other process values independently of the actuator outputs (e.g. operator buttons, scraper end positions).

The sensor inputs are designed as ignition protection type ia.

Output	Sensor	Terminal designation	
		Polarity +	Polarity -
1	1.1	3	4
	1.2	5	6
2	2.1	9	10
	2.2	11	12
3	3.1	15	16
	3.2	17	18
4	4.1	21	22
	4.2	23	24

9 SETTING STATION ADDRESSES PROFIBUS PA

DIP switches 1 to 7 Bit 1 to Bit 7



The DIP switches are not read in until the device is switched on.

In the case of the PROFIBUS PA each station receives an address. These addresses are set with the DIP switches 1 to 7.

The permitted address area is between 3 and 124.

Settings:

2 ⁰	2 ¹	2 ²	2 ³	2 ⁴	2 ⁵	2 ⁶	
DIP1	DIP2	DIP3	DIP4	DIP5	DIP6	DIP7	Address
ON	ON	OFF	OFF	OFF	OFF	OFF	3
							:
							:
OFF	OFF	ON	ON	ON	ON	ON	124
ON	OFF	ON	ON	ON	ON	ON	
OFF	ON	ON	ON	ON	ON	ON	125
							126

Delivery status: Address 126



If switch 8 is in the ON position, the internal address is used. This address can be set via the field bus.

9.1 LED display

The LED flashes if the device is using cyclic data transfer.

The LED lights up briefly when the device is connected.

If the device establishes an internal fault, the LED stays on constantly.

9.2 Watchdog

To improve fault detection, we recommend operating the device using cyclic data transfer with "**DP watchdog**".

10 NETWORK CONFIGURING PROFIBUS PA

10.1 Storage allocation for user data transfer

Basis: Handbook for your PLC

→ To implement the correct settings of the configuration program, copy the device-specific file (buer6521.GSD) from Bürkert into the directory which contains the configuration software. To read in and process the configuration, please read the documentation for your PLC or your control system.

Further information on the storage allocation can be found in the handbook.

10.2 System parameters



All profile information refers to profile version 3.0 Class B. This is where you will also find detailed documentation on the parameters.



▪ When writing parameters, ensure that the power is on.

10.2.1 Description of the block parameters of the function block

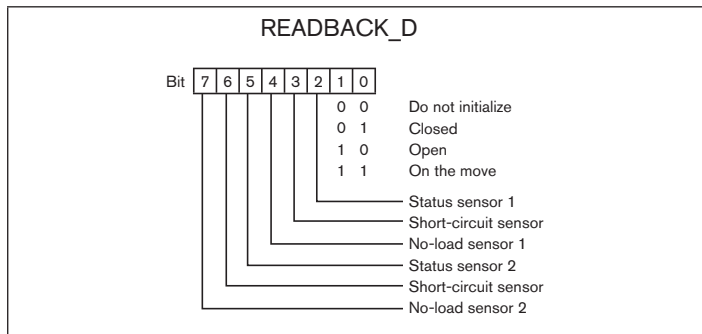

Parameter	Description
READBACK_D	→ This parameter returns the position of the valve and the sensors <ul style="list-style-type: none"> ▪ 1 = active ▪ 0 = inactive
SP_D	Set-point value → Bit 0 in the value specifies the valve position. The transferred status must be a "good" status, e.g. 0x80

11 START-UP

11.1 Safety instructions



WARNING!

Risk of injury due to improper operation.

Improper operation may result in injuries as well as damage to the device and the area around it.

- ▶ Before start-up, ensure that the operating personnel are familiar with and completely understand the contents of the operating instructions.
- ▶ Observe the safety instructions and intended use.
- ▶ Only adequately trained personnel may start up the equipment/ the device.

11.2 Start-up

Before starting up the device, ensure that:

- the connection has been made properly.
- the Power I/O Box has been installed correctly.
- the Power I/O Box has not been damaged.

11.3 Shutdown

→ Deaerate the system and switch the power supply off.

→ Remove the device.

→ Keep the device in the original packaging or in appropriately protective packaging.

11.4 Starting up the device again

- Acclimatize the device before restarting it.
- Then proceed as described in chapter "[8 Installation](#)".

12 MAINTENANCE

The Power I/O Box Type 8643 is almost maintenance-free when operated according to these operating instructions.



WARNING!

Dangerous situations may occur when performing maintenance work.

- ▶ This work may be carried out by authorized technicians only, who are trained for work in a potentially explosive environment.
- ▶ Observe the national regulations which apply to the installation/operation of electrical equipment in areas where there is a risk of explosions.

As part of maintenance check:

- that the cable is secure,
- the plastic housing for cracks,
- the seal of the cable entry for damage,
- that the device functions as intended.

13 TRANSPORTATION, STORAGE, DISPOSAL

NOTE!

Transport damage.

Inadequately protected devices may be damaged during transportation.

- ▶ Protect the device against moisture and dirt in shock-resistant packaging during transportation.
- ▶ Prevent the temperature from exceeding or dropping below the permitted storage temperature.
- ▶ Protect the electrical interfaces of the coil and the pneumatic connections from damage by placing protective caps on them.

Incorrect storage may damage the device.

- ▶ Store the device in a dry and dust-free location.
- ▶ Storage temperature -20 to $+55$ °C.

Damage to the environment caused by device components contaminated with media.

- ▶ Observe applicable disposal and environmental regulations.
- ▶ Observe the national waste disposal regulations.

- Dispose of the device and packaging in an environmentally friendly manner.

www.burkert.com