

Type 8605

Digital Control Electronics for Proportional Valves

Digitale Ansteuerelektronik für Proportionalventile

Régulateur électronique numérique pour vannes proportionnelles



Quickstart

Contents

1	Quickstart	2
2	Authorized use	3
3	Basic safety instructions.....	4
4	General Information.....	5
5	Product Description	5
6	Technical Data	6
7	Installation.....	7
8	Cleaning.....	10
9	Transport.....	10
10	Storage	10
11	Disposal.....	10

1 QUICKSTART

Quickstart contain important information.

- ▶ Read the Quickstart carefully and follow the safety instructions.
- ▶ Keep Quickstart in a location where they are available to every user.
- ▶ The liability and warranty for the device are void if the Quickstart are not followed.

Quickstart for Type 8605 explains, for example, how to install and start-up the device. A detailed description of the device can be found in the operating instructions for Type 8605. These instructions also include the warranty provisions and details about the correct disposal of the device.



The operating instructions can be found on the enclosed CD and on the Internet at: www.burkert.com

1.1 Symbols

- ▶ Designates instructions for risk prevention.
- Designates a procedure which you must carry out.



DANGER!

Immediate danger! Serious or fatal injuries.



WARNING!

Possible danger! Serious or fatal injuries.



CAUTION!

Danger! Moderate or minor injuries.

NOTE!

Warns of damage to property.



Important tips and recommendations.



Refers to information in these operating instructions or in other documentation.

1.2 Definitions of terms

In these instructions, the term “device” always refers to digital control electronics for proportional valves Type 8605.

2 AUTHORIZED USE

Non-intended use of the device may be a hazard to people, nearby equipment and the environment.

- ▶ The device is designed for controlling Bürkert proportional valves.
- ▶ The device must not be exposed to direct sunlight.
- ▶ Do not use the device outdoors.
- ▶ To ensure that the device functions perfectly, set the PWM frequency which is suitable for the valve. A table of set values can be found on the Bürkert homepage www.burkert.com → Type 8605.
- ▶ Use according to the authorized data, operating conditions and conditions of use specified in the contract documents and operating instructions. These are described in the chapter entitled “[6 Technical Data](#)”.
- ▶ The device may be used only in conjunction with third-party devices and components recommended and authorized by Bürkert.
- ▶ Correct transportation, correct storage and installation and careful use and maintenance are essential for reliable and faultless operation.
- ▶ Use the device only as intended.

3 BASIC SAFETY INSTRUCTIONS

These safety instructions do not make allowance for any contingencies and events which may arise during assembly, operation and maintenance.



Risk of injury from high pressure!

- ▶ Before loosening the lines and valves, turn off the pressure and vent the lines.

Risk of injury due to electrical shock!

- ▶ Before loosening the lines and valves, switch off.
- ▶ Before working on the system or device, switch off the power supply and secure to prevent reactivation.
- ▶ Observe applicable accident prevention and safety regulations for electrical equipment.

There is a risk of injury when the pressure drops in the system!

- ▶ Avoid pressure drops!
- ▶ Design the pressure supply system with as large a volume as possible, even with up line devices such as e. g. pressure regulators, air conditioners, shut-off valves.

General hazardous situations.

To prevent injury, ensure that:

- ▶ That the system cannot be activated unintentionally.
- ▶ Installation and repair work may be carried out by authorised technicians only and with the appropriate tools.
- ▶ After an interruption in the power supply or pneumatic supply, ensure that the process is restarted in a defined or controlled manner.
- ▶ The device may be operated only when in perfect condition and in consideration of the operating instructions.
- ▶ The general rules of technology apply to application planning and operation of the device.

NOTE!

Electrostatic sensitive components / modules!

The device contains electronic components which react sensitively to electrostatic discharge (ESD). Contact with electrostatically charged persons or objects is hazardous to these components. In the worst case scenario, they will be destroyed immediately or will fail after start-up.

- Observe the requirements in accordance with EN 61340-5-1 and 5-2 to minimise or avoid the possibility of damage caused by sudden electrostatic discharge!
- Do not touch live electronic components!

4 GENERAL INFORMATION

4.1 Warranty

The warranty is only valid if the device is used as authorized in accordance with the specified application conditions.

4.2 Information on the Internet

Operating instructions and data sheet for Type 8605 can be found on the Internet at: www.burkert.com

5 PRODUCT DESCRIPTION

5.1 Field of application

The Control Electronics, Type 8605, is designed for continuous operation in industrial environments, in particular in the fields of open-loop and closed-loop control engineering.

5.2 General description

The Digital Control Electronics for Proportional Valves, Type 8605 (hereinafter referred to as Control Electronics, Type 8605) Controls all Bürkert proportional valves with a max. current in the range from 40 to 2000 mA.

It transforms an external standard signal into a pulse-width modulated voltage signal (PWM) that is supplied to the solenoid coil of the proportional valve.

A given value of the average coil current is thereby assigned to each value of the input signal. The proportional opening of the valve can be set via the coil current.

5.3 Forms of the device

5.3.1 Type 8605 cable plug version



Fig. 1: Type 8605 Cable plug version

Plug-in version on valves with connector pattern A (e. g. types 2833, 2834, 2835, 2836, 2863, 2865, 2873, 2875, 6024, 6223).

The operating unit can be removed after the setting process. During operation of the Control Electronics 8605 in cable plug version without operating unit, the operating status is indicated by two LEDs.

Device variants:

- Variant 1 for valves with a max. current from 200 to 1000 mA
- Variant 2 for valves with a max. current from 500 to 2000 mA

5.3.2 Type 8605 DIN rail version



Fig. 2: Type 8605 DIN rail version

Separate electronics in housing for DIN rail mounting to DIN EN 50022. This form is suitable for all proportional valves in the indicated current range. The operating unit cannot be removed.

Device variants:

- Variant 1 for valves with a max. current from 40 to 220 mA
- Variant 2 for valves with a max. current from 200 to 1000 mA
- Variant 3 for valves with a max. current from 500 to 2000 mA

6 TECHNICAL DATA

6.1 Operating Conditions

Power supply	12...24 V DC \pm 10% Residual ripple 5 %
Power consumption	ca. 1 W
Output current (on the valve)	max. 2 A
Operating temperature	-10 ... 60 °C / 14 ... 140 °F
Interference resistance	to EN50082-2
Emission	to EN50081-2
Current range, depending on the version for valves	40 ... 220 mA, 200 ... 1000 mA, 500 ... 2000 mA
Standard signal input	
Voltage (0 ... 5, 0 ... 10 V)	input impedance > 20 k Ω
Current (0 ... 20, 4 ... 20 mA)	input impedance < 200 Ω

Housing: DIN rail version

Degree of protection	IP40 (DIN EN 60529)
Materials	Polyamide / PBT
Dimensions	LxWxH: 97 x 27 x 57 mm

Housing: Cable plug version

Degree of protection	IP65 (DIN EN 60529)
Materials	Polyamide / PC
Dimensions	LxWxH: 70 x 32 x 42.5 mm

7 INSTALLATION

7.1 Safety instructions



DANGER!

Risk of injury from high pressure in the equipment!

- ▶ Before loosening the pipes and valves, turn off the pressure and vent the lines.

Risk of injury due to electrical shock!

- ▶ Before reaching into the device or the equipment, switch off the power supply and secure to prevent reactivation.
- ▶ Observe applicable accident prevention and safety regulations for electrical equipment.



WARNING!

Risk of injury from improper installation!

- ▶ Installation may be carried out by authorized technicians only and with the appropriate tools.

Risk of injury from unintentional activation of the system and an uncontrolled restart!

- ▶ Secure system from unintentional activation.
- ▶ Following assembly, ensure a controlled restart.

7.2 Electrical connections

7.2.1 Type 8605 cable plug version

Type 8605 with cable plug version is connected electrically via a 4-pin terminal strip in the device.

Cable diameter	6 ... 8 mm
Cable cross-section	max. 0.75 mm ²
Cable connections	Cable gland or plug-in connector M12, 4-pin

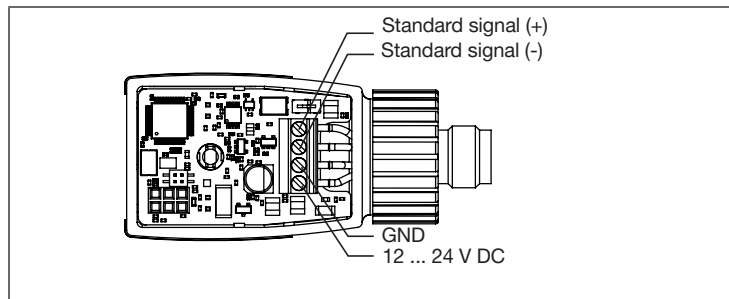

Fig. 3: Terminal strip connection

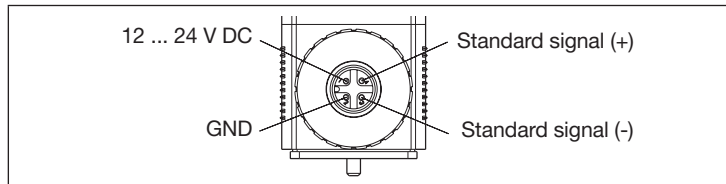

Fig. 4: Plug connector connection

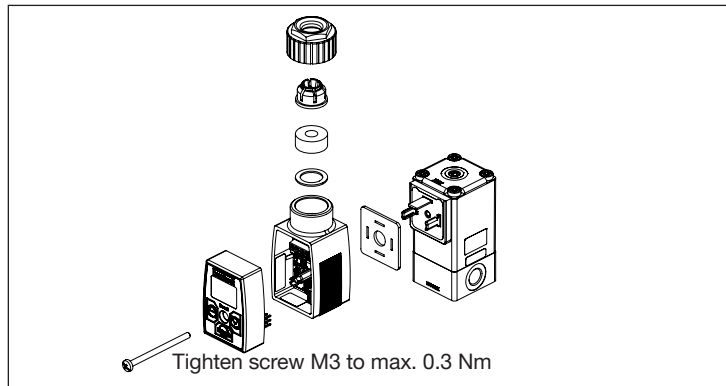

Fig. 5: Assembly at the valve

NOTE!

Ensure proper seating of the valve when screwing onto the valve (cable plug version).

Do not tighten the screw M3 too tightly (max. 0.3 Nm), as otherwise the housing will be deformed and proper operation of the keys will no longer be possible.

7.2.2 LEDs during operation without operating unit

During operation of the control electronics Type 8605 cable plug version without operating unit, the operating status is indicated by two LEDs.

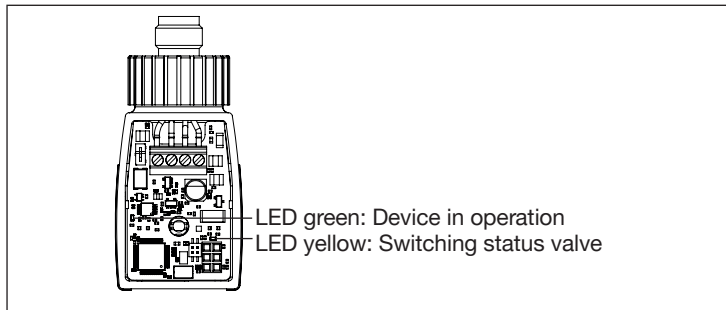

Fig. 6: LEDs for version without operating unit

7.2.3 Type 8605 DIN rail version

The electrical connection of Type 8605 DIN rail version is made via terminal strips.

Terminal strip		Cable cross-section
2-pin	For valve	max. 1.5 mm ²
4-pin	For voltage supply and standard signal	max. 1.5 mm ²

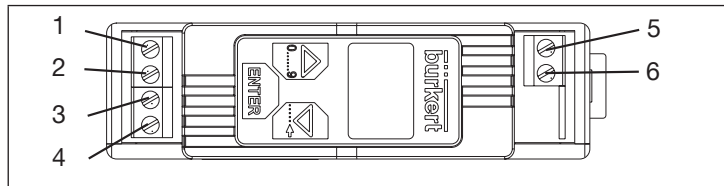

Fig. 7: Terminal strip connection

Legend to figure:

1	12 ... 24 V DC	6	Valve
2	GND		
3	Standard signal (-)		
4	Standard signal (+)		
5	Valve		

8 CLEANING

Use the normal cleaning agents to clean the Control Electronics, Type 8605. Use no alkaline cleansing agents, as these have a damaging effect on the materials used.

9 TRANSPORT

NOTE!

Transport damages!

Inadequately protected equipment may be damaged during transport.

- During transportation protect the device against wet and dirt in shock-resistant packaging.
- Avoid exceeding or dropping below the allowable storage temperature.

10 STORAGE

NOTE!

Incorrect storage may damage the device.

- Store the device in a dry and dust-free location!
- Storage temperature. -40 - + 55 °C.

10.1 Decommissioning

Switch off the Control Electronics Type 8605 as follows:

- Depressurize the system.
- Switch off the power supply.
- Remove the Control Electronics.
- Keep the control electronics in the original packaging or in some other suitable packaging.

10.2 Restarting

Switch on the Control Electronics Type 8605 again as follows:

- Unpack the Control Electronics and allow it to reach room temperature before switching on again.
- Then proceed as described in chapter [“7 Installation”](#).

11 DISPOSAL

NOTE!

Damage to the environment caused by device components contaminated with media.

- Dispose of the device and packaging in an environmentally friendly manner.
- Observe applicable regulations on disposal and the environment.

Bürkert Fluid Control Systems
Sales Center
Christian-Bürkert-Str. 13-17
D-74653 Ingelfingen
Tel. + 49 (0) 7940 - 10 91 111
Fax + 49 (0) 7940 - 10 91 448
E-mail: info@burkert.com

International address
www.burkert.com

Manuals and data sheets on the Internet: www.burkert.com
Bedienungsanleitungen und Datenblätter im Internet: www.buerkert.de
Manuel d'utilisation et fiches techniques sur Internet : www.buerkert.fr

© Bürkert Werke GmbH & Co. KG, 2008 - 2020
Operating Instructions 2003/08_EU-ML_00805637 / Original DE

www.burkert.com