

# Type 8318

## Pressure Sensor with IO-Link

Use  **IO-Link**  
Universal · Smart · Easy



### Operating Manual



<b>1</b>	<b>Introduction</b> .....	<b>4</b>
1.1	Safety information .....	4
1.2	Description .....	5
1.3	Display and connection elements .....	5
1.4	Dimensions .....	6
<b>2</b>	<b>Identifying the device version</b> .....	<b>9</b>
2.1	Nameplate .....	9
<b>3</b>	<b>Mounting</b> .....	<b>11</b>
<b>4</b>	<b>Electrical connection</b> .....	<b>12</b>
4.1	Connection examples .....	13
<b>5</b>	<b>Configuration</b> .....	<b>14</b>
<b>6</b>	<b>Functions</b> .....	<b>15</b>
6.1	Switching points .....	15
6.1.1	Hysteresis function .....	16
6.1.2	Window function .....	17
6.1.3	Switch-on delay/switch-off delay .....	18
6.2	Fine adjustment .....	19
6.3	Teach functions .....	21
6.4	Fault signaling .....	22
<b>7</b>	<b>Parameter overview</b> .....	<b>24</b>
7.1	Process data .....	24
7.2	Configuration data .....	25
7.3	Service data .....	28
<b>8</b>	<b>Technical data</b> .....	<b>29</b>
8.1	Input .....	29
8.2	Output .....	30
8.3	Interface .....	30
8.4	Electrical data .....	31
8.5	Mechanical features .....	31
8.6	Environmental influences .....	32

# 1 Introduction

---

## 1.1 Safety information

### General

This manual contains information that must be observed in the interest of your own safety and to avoid material damage. This information is supported by symbols which are used in this manual as indicated.

Please read this manual before starting up the device. Store this manual in a place that is accessible to all users at all times.

If difficulties occur during startup, please do not intervene in any way that could jeopardize your warranty rights!

### Warning symbols



#### CAUTION!

This symbol in connection with the signal word indicates that **material damage or data loss** will occur if the respective precautionary measures are not taken.

---



#### READ THE DOCUMENTATION!

This symbol, which is attached to the device, indicates that the associated **documentation for the device** must be **observed**. This is necessary to identify the nature of the potential hazard, and to take measures to prevent it.

---

### Note symbols



#### NOTE!

This symbol refers to **important information** about the product, its handling, or additional benefits.

---



#### REFERENCE!

This symbol refers to **additional information** in other sections, chapters, or other manuals.

---



#### DISPOSAL!

At the end of its service life, the device and any batteries present do not belong in the trash! Please ensure that they are **disposed of** properly and in an **environmentally friendly** manner.

---

## 1.2 Description



### NOTE!

Please read this manual before starting up the device. Store this manual in a place that is accessible to all users at all times.

The pressure sensor serves to measure relative and absolute pressure and monitor it in liquids and gases. The effect of the pressure on the pressure sensor generates a signal, which is amplified, digitalized, and processed.

The pressure sensor is equipped with an IO-Link interface according to specification 1.1. IO-Link supports bidirectional communication and is used to exchange process data, parameters, diagnostic information, and status messages. The two green LEDs are permanently lit as soon as voltage is supplied to the device. Once an IO-Link connection is established, the LEDs flash.

The switching behavior and the switching thresholds of the switching outputs (max. 2 pieces; p or n switching) can be individually configured - along with many other parameters. Any IO-Link master can be used for the configuration.

The pressure sensor is therefore suitable for use in plant and mechanical engineering in connections to automation systems. A variety of pressure connections and measuring ranges are available to the user.

## 1.3 Display and connection elements

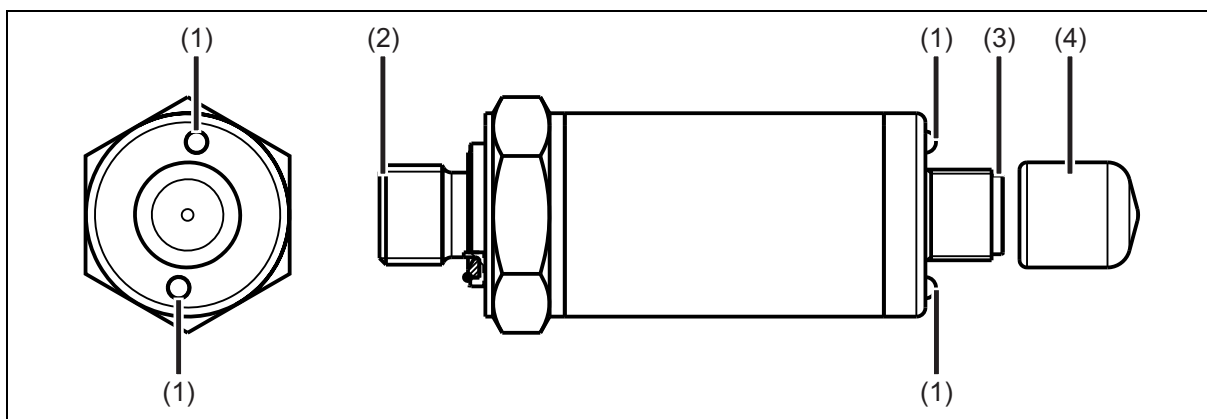

- (1) Status LEDs
- (2) Pressure connection with membrane for recording pressure levels
- (3) M12 connection
- (4) Protective cap for storage and transport

# 1 Introduction

## 1.4 Dimensions

Non-front-flush versions  
G 1/4 DIN EN 837, G 1/2 DIN EN 837, 1/4-18 NPT,  
G 1/4 DIN 3852-11, G 1/2 DIN 3852-11; measuring  
range  $\leq 100$  bar

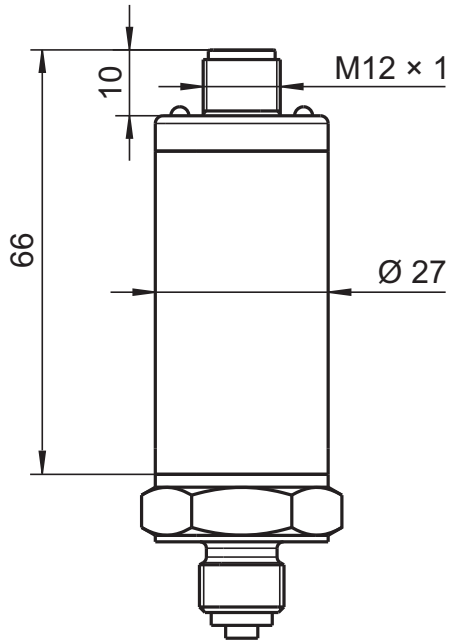

Front-flush version  
G 3/4 DIN EN ISO 228-1, G 1/2 with double seal, G 3/4  
with double seal; measuring range  $\leq 100$  bar

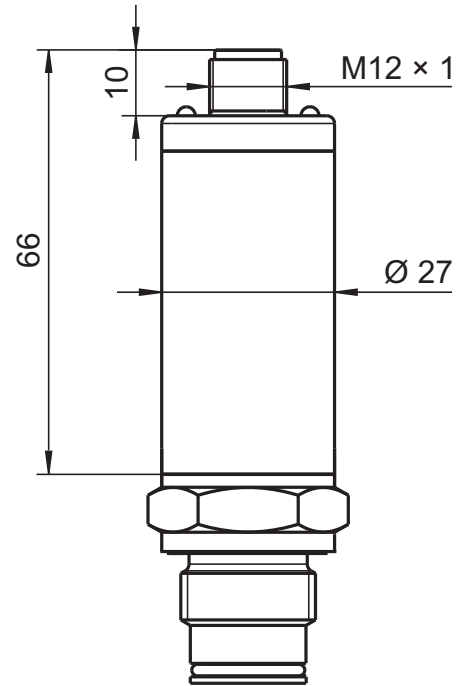

Hygienic process connection; measuring range  
 $\leq 100$  bar

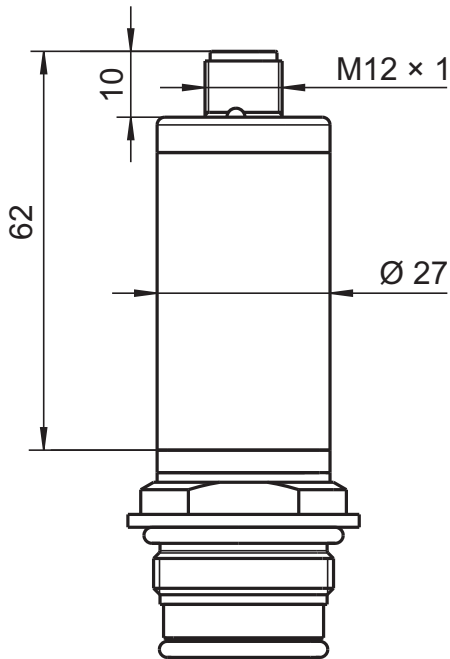

High-pressure version; measuring range  $> 100$  bar

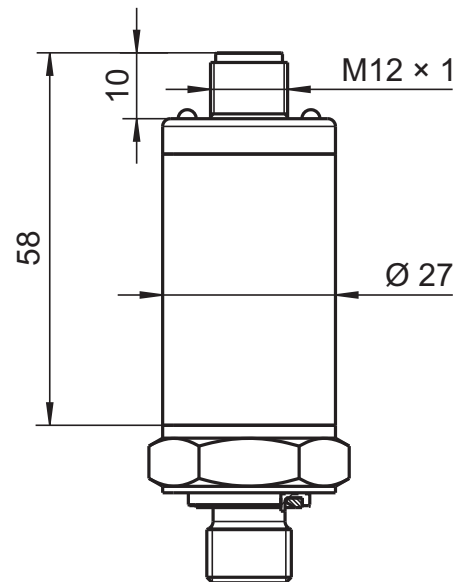

## Process connections

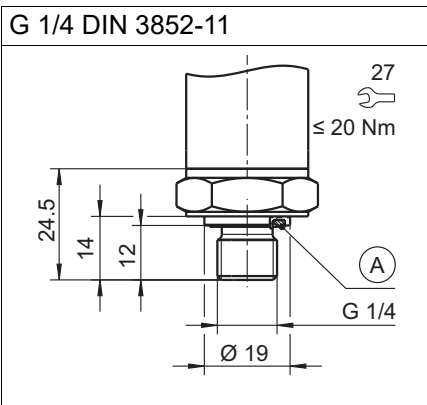
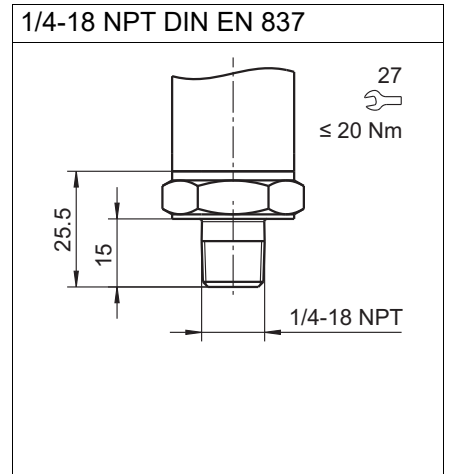
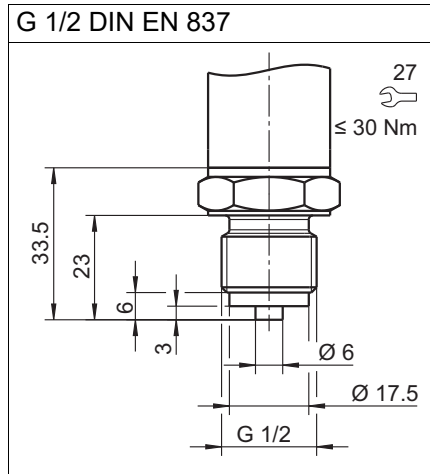
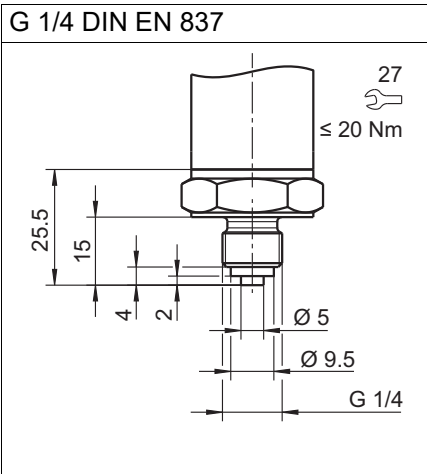

A Profile seal G 1/4

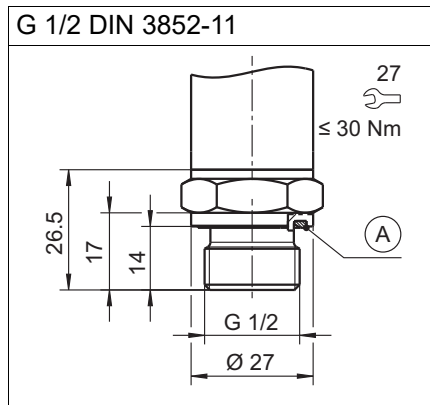

A Profile seal G 1/2

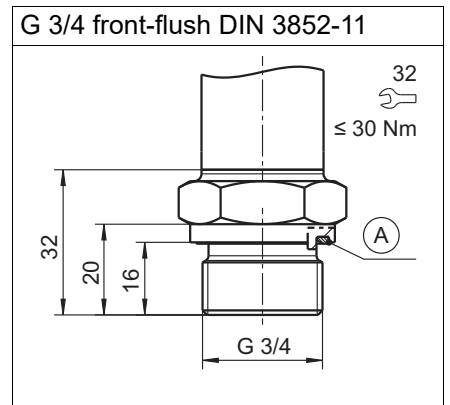

A Profile seal G 3/4

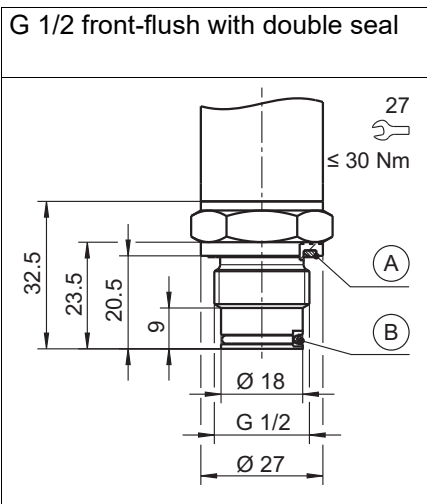

A Profile seal G 1/2

W O-ring 15.1 × 1.6

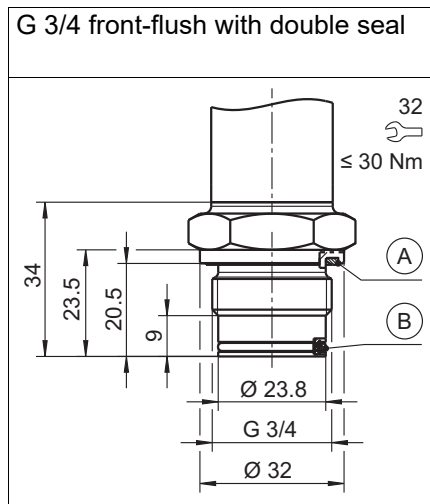

A Profile seal G 3/4

W O-ring 20.35 × 1.78

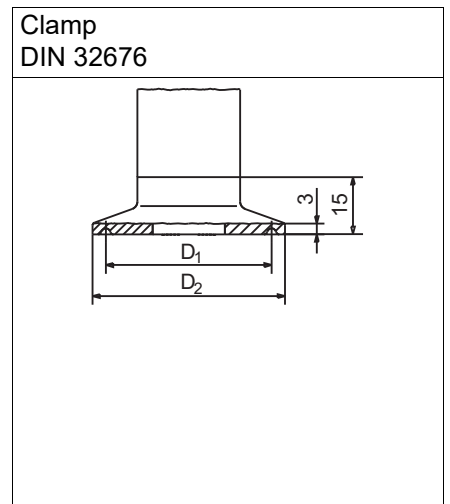

# 1 Introduction

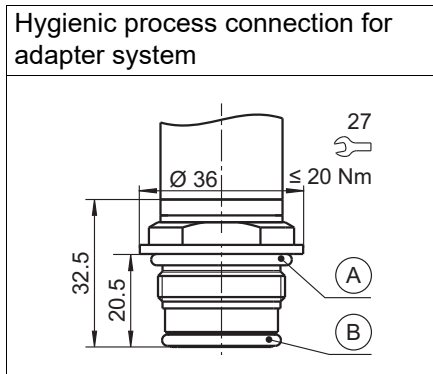

A O-ring 26 × 2.5

W O-ring 21 × 2.5

DN DIN 32676	DN (Zoll)	Nominal size ISO 2852	Ø D <sub>1</sub>	Ø D <sub>2</sub>
10		12	27.5	34
15		12.7		
20		17.2		
		21.3		
25	1"	25	43.5	50.5
32	1.5"	33.7		
40		38		
50	2"	40	56.5	64
		51		



# 2 Identifying the device version

## 2.1 Nameplate

### Position

The nameplate is located on the housing surface.

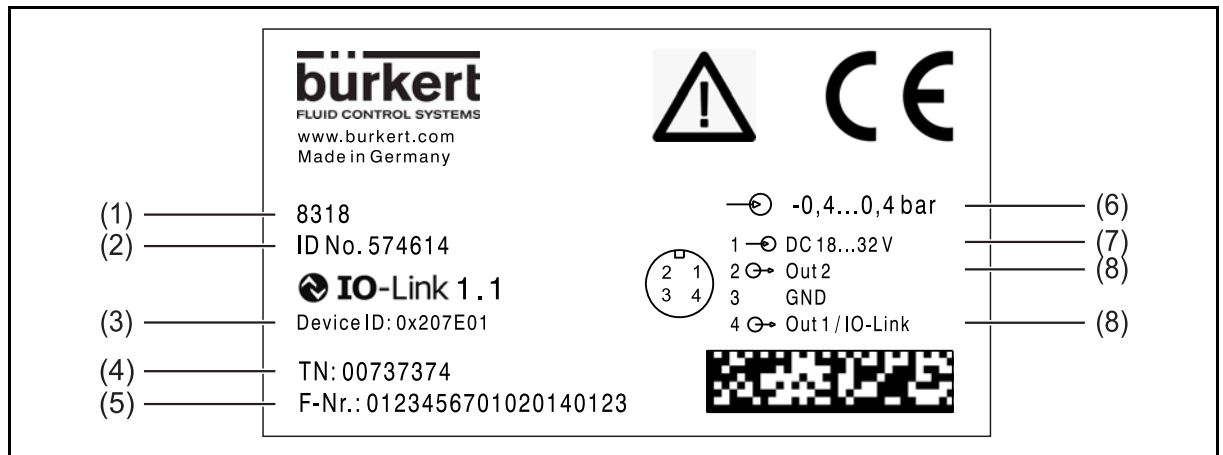

- |     |   |     |                               |
|-----|---|-----|-------------------------------|
| (1) | Device type no.   | (2) | Device ID no.                 |
| (3) | Device ID IO-Link   | (4) | TN                            |
| (5) | Fabrication no.   | (6) | Input                         |
| (7) | Voltage supply, for more in-depth information, see „technical data“ | (8) | Outputs/digital communication |

### Device ID no.

The device ID number uniquely identifies an article and, together with the device type no., determines the selected device variant.

### TN

Internal no.

### Device ID IO-Link

The device ID can help when localizing the device description file (IODD), which can be found on the manufacturer's website and also downloaded if necessary.

#### **Downloading the IODD:**

1. Go to web page <https://country.burkert.com/>
2. Select your country
3. Click on continue the website
4. Confirm or change cookie settings
5. Enter the device type number, e.g. 8318 (see device nameplate) in the search field
6. Click on the first result of the search
7. In the area Software download the ZIP file Device Description
8. Unpack the ZIP file (all or just the IODD file)
9. Identify and select the required IODD via IO-Link Device ID (see device nameplate)

*The IODD is now available for use with the IO-Link master's configuration tool. This can be used to configure and check the device.*

Instead of the manufacturer's website, you can also use the address: <http://ioddfinder.io-link.com>.

## 2 Identifying the device version

---

### **Fabrication number (F-Nr)**

Among other things, the fabrication number indicates the date of manufacture (year/calendar week).

### **Date of manufacture**

The device's date of manufacture (year and calendar week) is part of the fabrication number. Digits 12 to 15 denote the year of manufacture and the calendar week.

The device may only be installed, connected and started up by qualified and authorized personnel observing these operating instructions, the applicable standards, and the legal requirements (depending on the application).

The device does not meet the requirements for "safety accessories" within the meaning of the Pressure Equipment Directive 2014/68/EU.

If you experience difficulties during installation and startup, please contact the manufacturer.

The device can be installed in any position.



**NOTE!**

The pressure sensor is not suitable for safety-critical applications.

---



**NOTE!**

The pressure sensor is not suitable for installation and application in potentially explosive areas.

---



**NOTE!**

The pressure sensor must be connected to the plant's potential equalization system via the process connection.

---

### Mounting the sensor

- Insert the pressure sensor into the corresponding drilled hole and tighten it by hand, making sure the profile seal and/or O-ring (if fitted) are sitting correctly
  - Tighten the pressure sensor with a suitable wrench
- ⇒ Wrench size and torque see "Process connections", Page 7

## 4 Electrical connection

Connection	Terminal assignment	
	M12 × 1 round plug (A-coded, non rotating)	
<b>Switch operation</b>		
Voltage supply <sup>a</sup> DC 9,6 to 32 V	1 BN (brown) <sup>b</sup> 3 BU (blue)	L+ L-
Switching output 1	4 BK (black)	C/Q = OUT1
Switching output 2	2 WH (white)	I/Q = OUT2
<b>IO-Link operation</b>		
Voltage supply <sup>a</sup> DC 18 to 32 V	1 BN (brown) 3 BU (blue)	L+ L-
IO-Link	4 BK (black)	C/Q = IO-Link
Switching output 2	2 WH (white)	I/Q = OUT2
<b>Potential equalization</b>		
Functional bonding conductor FB <sup>c</sup>		

<sup>a</sup> The auxiliary energy of the pressure sensor must meet SELV requirements; optionally, an energy-limited current-circuit according to DIN EN 61010-1 and UL 61010-1 can be used.

<sup>b</sup> The colour coding is **only** valid for A-coded standard cables!

<sup>c</sup> The pressure sensor must be connected to the plant's potential equalization system via the process connection.

## 4.1 Connection examples

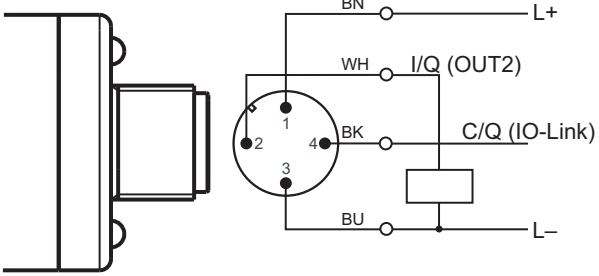
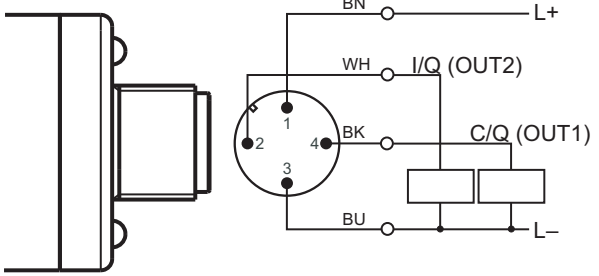
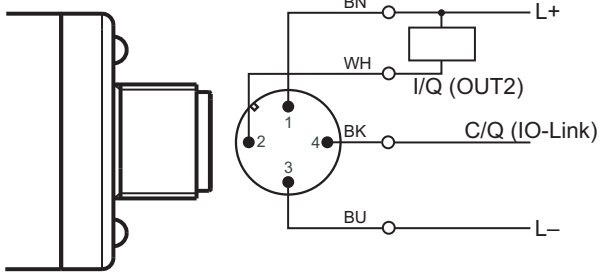
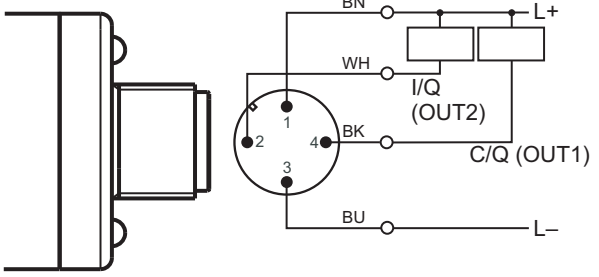
IO-Link operation with 1 switching output	Switch operation with 2 switching outputs
<p>p switching (PNP)</p> 	<p>p switching (PNP)</p> 
<p>n switching (NPN)</p> 	<p>n switching (NPN)</p> 

# 5 Configuration

---

## Starting up the IO-Link master and configuration tool

If you are using a conventional IO-Link master, you must complete the following steps to configure the sensor.

1. Start up the hardware and software for the IO-Link master
2. Load the sensor's device description file (IODD)
  - a) Open the manufacturer's website (change the language to English if necessary)
  - b) Use the search function to select the sensor
  - c) Under "Software", download the ZIP file containing the collection of IODDs
  - d) Extract all files from the ZIP folder
3. Start the configuration tool
4. Update the device catalog (import the IODD; localize using the "device ID" on the nameplate or the text file in the IODD collection)
5. Create a new project
6. Establish a connection
7. Configure, extract, monitor, etc., the sensor

Instead of the manufacturer's website, you can also use the address: <http://ioddfinder.io-link.com>.

## Configuration tool (overview)

Depending on the configuration tool, the menu structure contains different areas. The typical structure is listed below:

- Identification and information  
These areas show information on the manufacturer and device as well as general information.
- Parameters  
This section is used to configure the device.
  - General parameters
  - Switching points ⇨ chapter 6.1 "Switching points", Page 15
  - Fine adjustment ⇨ chapter 6.2 "Fine adjustment", Page 19
  - Event settings ⇨ chapter 6.4 "Fault signaling", Page 22
  - Versions
  - Service information
- Monitoring  
In this area process data can be extracted (snapshot).
- Diagnosis and events  
These areas show diagnostic data and information about events.
- Process data  
This area shows the current process data, which is extracted cyclically.

**CAUTION!**

Write operations to some R/W parameters result in them being saved to the EEPROM. This memory module has only a limited number of write cycles (approx. 100,000).

Frequent writing of certain parameters can therefore result in a memory error.

- ▶ Frequent writing cycles should thus be avoided.

## 6.1 Switching points

Depending on the operating mode, the sensor has 1 or 2 switching outputs. It automatically detects the connection type and responds accordingly. Separate parameters are available for both switching outputs.

Operating mode	Output	Pin at the M12 connection
SIO mode (SIO = Standard IO)	Switching output 1	C/Q (OUT1)
	Switching output 2	I/Q (OUT2)
IO-Link mode	IO-Link communication	C/Q (IO-Link)
	Switching output 2	I/Q (OUT2)

### Parameter

Parameter	Selection/settings	Description
Switching behavior	<b>Inactive</b> Hysteresis function, N/O Contact Hysteresis function, N/C Contact Window function, N/O Contact Window function, N/C Contact	When inactive is selected, the selected switching output is not activated.
Switching point (SP) or window high (FH)	-99999 to <b>0</b> to +99999	The selected switching output is only activated if $rSP < SP$ or $FL < FH$ . ⇒ Chapter 6.1.1 ⇒ Chapter 6.1.2
Release point (rSP) or window low (FL)	-99999 to <b>0</b> to +99999	
Switch-on delay (VSP)	<b>0</b> to 100 s	⇒ Chapter 6.1.3
Switch-off delay (VrSP)	<b>0</b> to 100 s	
Output driver mode	<b>P-Switching</b> n switching	⇒ Chapter 4.1

# 6 Functions

## 6.1.1 Hysteresis function

The hysteresis function switches the output as soon as the switching point "SP" is reached. When the release point "rSP" is reached, the output switches again.

The hysteresis function distinguishes between N/C and N/O contacts.

Switching requirement: Switching point "SP"  $\geq$  Release point "rSP"

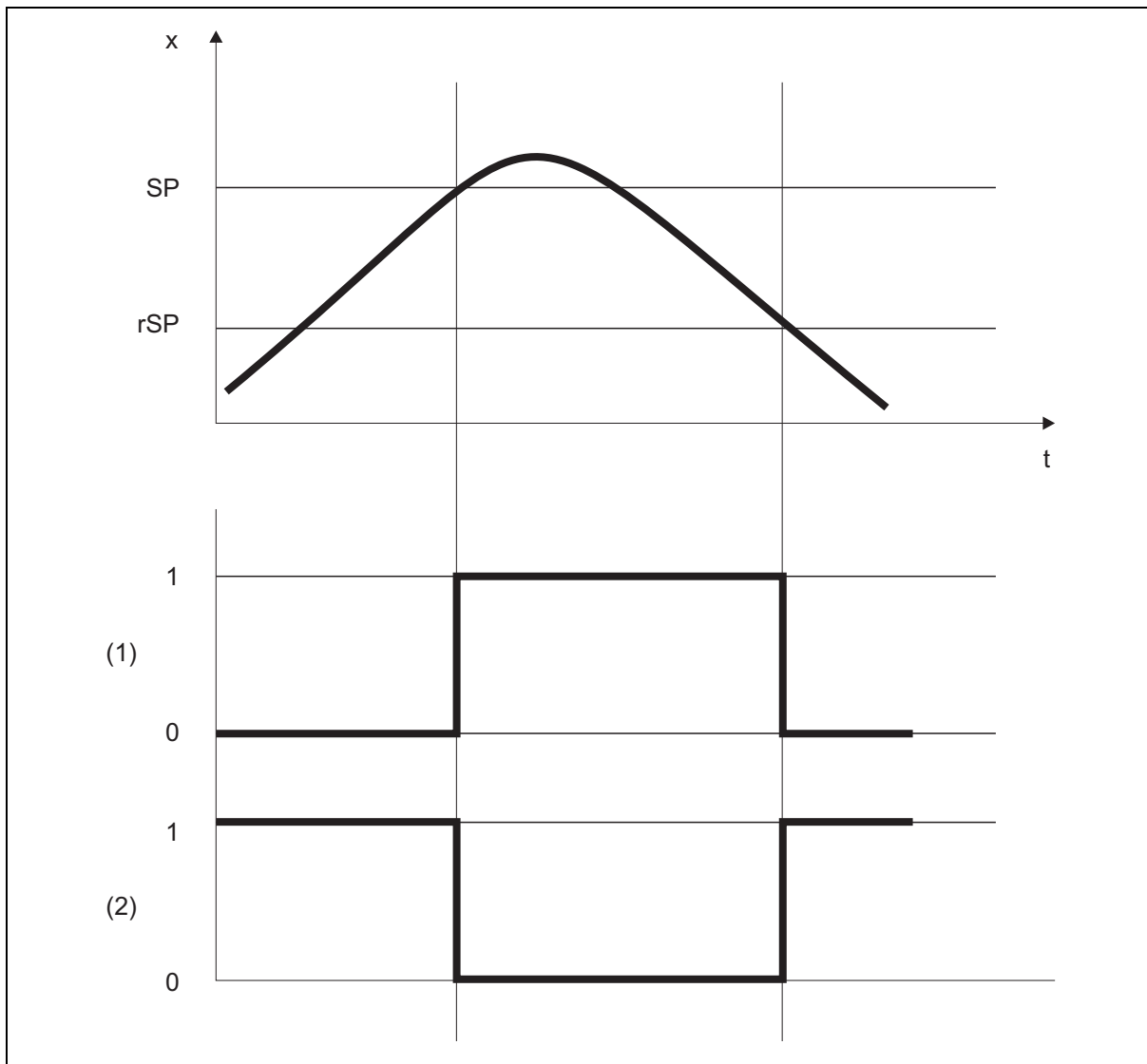

- x = Measured value
- t = Time
- SP = Switching point
- rSP = Release point
- (1) = N/O contact
- (2) = N/C contact



## 6.1.2 Window function

Under the window function, the window range is defined using the parameters window low "FL" (lower value) and window high "FH" (upper value). The output switches when the current measured value ( $x$ ) is between the two limits  $[(x > FL) \& (x < FH)]$ .

The window function distinguishes between N/C and N/O contacts.

Requirement: Window high "FH"  $\geq$  Window low "FL"

The window high "FH" and window low "FL" switching points have a fixed symmetrical hysteresis of  $\pm 0.25\%$  of the measuring range.

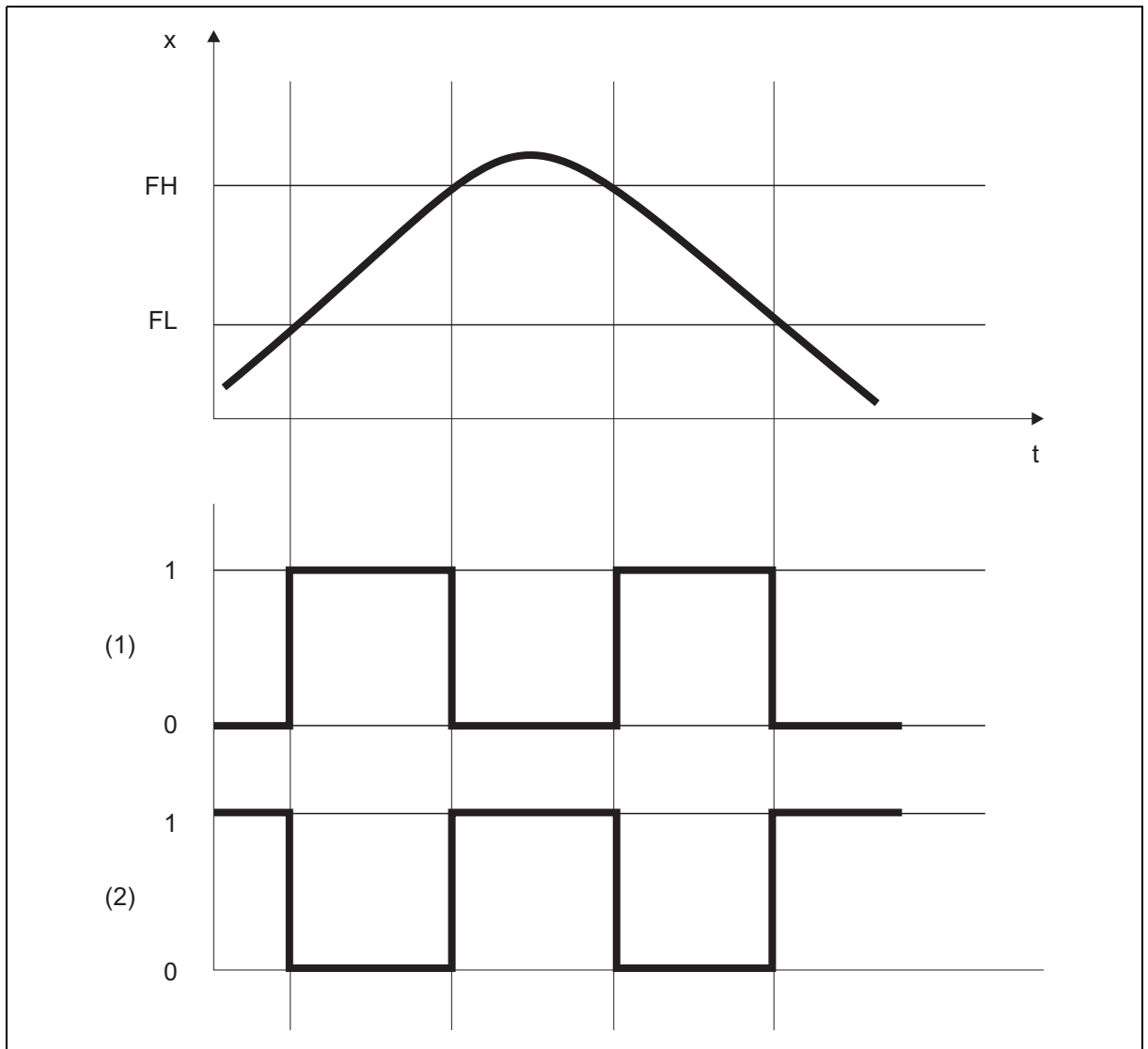

- x = Measured value
- t = Time
- FH = Window high
- FL = Window low
- (1) = N/O contact
- (2) = N/C contact

# 6 Functions

## 6.1.3 Switch-on delay/switch-off delay

The switch-on delay "VSP" and switch-off delay "VrSP" prevent switching of the output being triggered by peaks or drops in the measured values.

If the necessary measured value is no longer measured once the delay time has passed, the output is not switched.

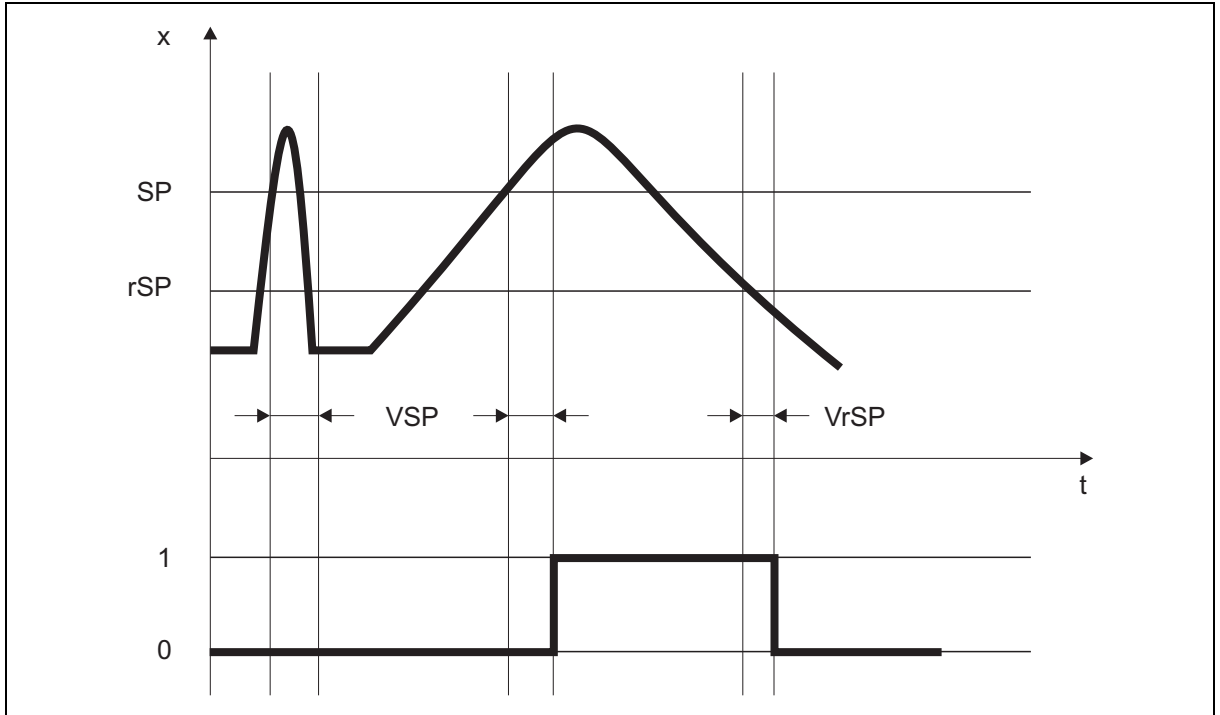

- $x$  = Measured value
- $t$  = Time
- $SP$  = Switching point
- $rSP$  = Release point
- $VSP$  = Switch-on delay
- $VrSP$  = Switch-off delay

## 6.2 Fine adjustment

You can use customer-specific fine adjustment to correct the measured values of the sensor. In contrast to offsetting, which is used to specify a constant correction value for the entire characteristic line, fine adjustment can also be used to change the gradient of the characteristic line.



### NOTE!

The fine adjustment data are not stored in the parameter manager.

### Parameter

Parameter	Selection/settings	Description
Active	No, Yes	Fine adjustment is only active if you select Yes
Actual start value	-99999 to <b>0</b> to +99999	Lower measured value
Target start value	-99999 to <b>0</b> to +99999	Lower reference value
Actual end value	-99999 to <b>0</b> to +99999	Upper measured value
Target end value	-99999 to <b>0</b> to +99999	Upper reference value

### Example

The pressure in a vessel is measured and displayed. Due to a deviation in the measurement, the sensor's measured value does not correspond to the actual value (reference measurement). The amount of deviation is different at the upper and lower measuring points, meaning an offset correction is not suitable.

Active: Yes  
 Actual start value: 15 bar (measured value)  
 Target start value: 20 bar (reference measurement)  
 Actual end value: 70 bar (measured value)  
 Target end value: 80 bar (reference measurement)

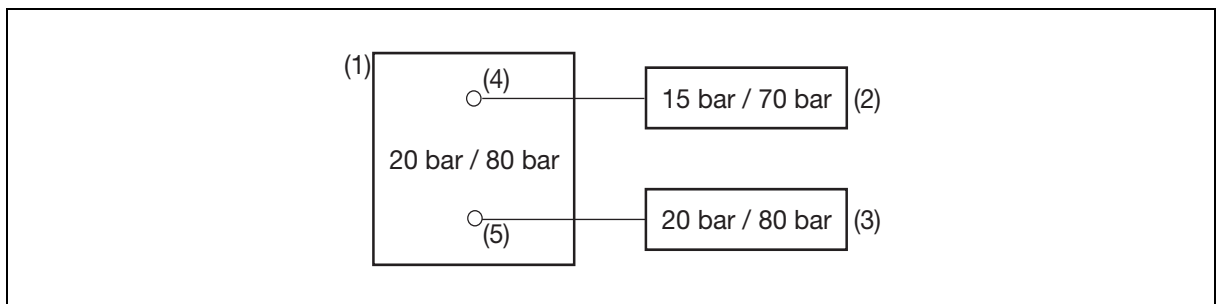

- (1) Vessel
- (2) Measured values from the sensor
- (3) Reference values
- (4) Sensor
- (5) Reference measurement

# 6 Functions

## Performing fine adjustment

- Determine the lower value (as low and constant as possible) with the reference measuring device.  
Example: Set vessel pressure to 20 bar.
- Enter the measured value as the actual start value and the reference value as the target start value.  
Example: Enter 15 and 20.
- Determine the upper value (as high and constant as possible) with the reference measuring device.  
Example: Increase vessel pressure to 80 bar.
- Enter the measured value as the actual end value and the reference value as the target end value.  
Example: Enter 70 and 80.



### NOTE!

The actual start value and actual end value can also be selected with the teach function.  
⇒ chapter 6.3 "Teach functions", Page 21

## Characteristic line

The following diagram shows the changes in the characteristic line caused by the fine adjustment (point of intersection with the x axis as well as the gradient).

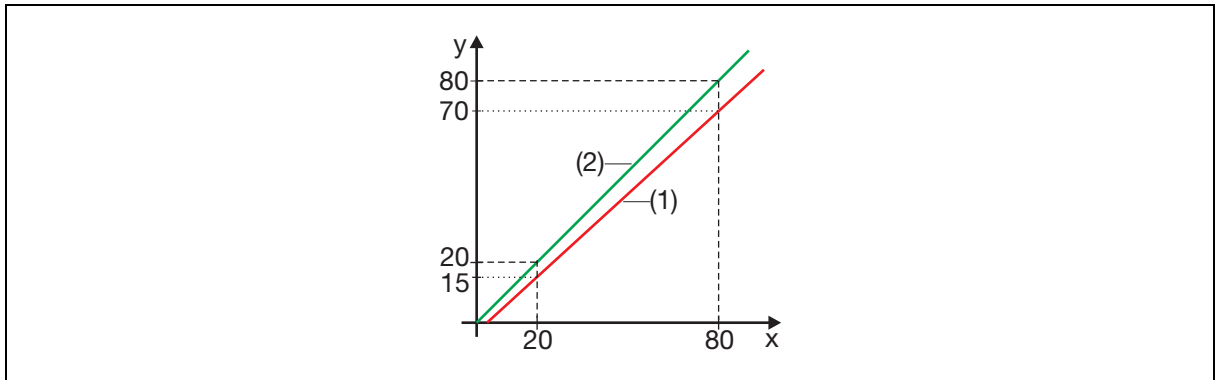

- y Measured value  
x Reference value  
(1) Characteristic line before fine adjustment  
(2) Characteristic line after fine adjustment

## Resetting the fine adjustment

To reverse the fine adjustment, the "Active" parameter must be set to "No".

## 6.3 Teach functions

The teach functions can be used to transfer certain commands to the sensor.

### Teach functions in the area of "General parameters"

Teach function	Description
Zero point adjustment	The current measured value is adopted as the offset.
Reset to default settings	All parameters under "General parameters", "Switching points", "Fine adjustment" and "Event settings" are reset to the default settings. The parameters under "Service information" stay the same.

### Teach functions in the area of "Fine adjustment"

Teach function	Description
Set actual start value	The current measured value is adopted as the actual start value.
Set actual end value	The current measured value is adopted as the actual end value.

### Teach functions in the area of "Service information"

Teach function	Description
Reset all	All parameters under "Service information" are reset to the default settings.
Reset operating hours counter	The operating hours counter is reset to the default settings.
Reset drag indicator min.	The stored minimum value is reset to the default settings.
Reset drag indicator max.	The stored maximum value is reset to the default settings.

#### NOTE!

After executing a teach function, the data may have to be exported from the sensor again.



# 6 Functions

## 6.4 Fault signaling

IO-Link offers a range of fault signaling options (device status, event codes, PDValid-Flag). Furthermore, malfunctions can also be signaled within the process data via the process value itself or the status of the process value.

### Overview

Description	Signaling via process value in PDI <sup>a</sup>	Process value status in PDI (1 byte)	Device status	Event code (Standard event)	Event activation or deactivation possible	Event error type
No error	-	-	0 (device is working properly)	-	-	-
Process value invalid	Yes	Bit0 (Process data invalid)	4 (failure)	0x1000	Yes	Error
Overrange	Yes			0x8C20	Yes	Error
Underrange	Yes				Yes	Error
Error in configuration data	No	Bit1 (Parameter error)	4 (failure)	0x6320	No	Error
Error in calibration data	No	Bit2 (Device is defective)	4 (failure)	0x5000	Yes	Error
Device is defective (Probe break, probe short circuit)	Yes					
Undervoltage	No	-	2 (Outside the specification)	0x5111	No	Warning
Temperature error, overload	No	-	4 (failure)	0x4000	No	Error

<sup>a</sup> PDI = Process Data Input

## Device status and event codes

Various events can be activated or deactivated via configuration parameters.

### PD-Valid Flag

If the device status is 4 (failure), the PDValid-Flag is set to zero (false). This means that all of the process data is invalid. In order to determine the precise cause, the process value or status bits can be evaluated.

### Process value

The fault signaling is displayed as a floating-point value or integer value. The following statuses are defined:

Error	Error code for floating-point values (TFLOAT)	Error code for integer values (TINT32)
Measuring range underflow	$1.0 \times 10^{37}$	2147483638
Measuring range overflow	$2.0 \times 10^{37}$	2147483639
Not a valid input value	$3.0 \times 10^{37}$	2147483640
Division by zero	$4.0 \times 10^{37}$	2147483641
Mathematical error	$5.0 \times 10^{37}$	2147483642
Probe short circuit	$7.0 \times 10^{37}$	2147483644
Probe break	$8.0 \times 10^{37}$	2147483645

### Process value status

⇒ See chapter 7.1 "Process data", Page 24

# 7 Parameter overview

## 7.1 Process data

The data is transferred in a cycle via the IO-Link interface to the IO-Link master (PDI = Process Data Input). The entire process data can be extracted via index 40 and subindex 0.

Designation	Data type	Value range	Default	Description
Pressure process value	TFLOAT or TINT32		0	The "Data format" configuration parameter can be used to switch between the data type TFLOAT and TINT32. ⇒Chapter 7.2
Pressure process value unit	TUINT8	0 = bar 1 = mbar 2 = ftH <sub>2</sub> O 3 = mmH <sub>2</sub> O 4 = mmHG 5 = psi 6 = inH <sub>2</sub> O 7 = inHG 8 = kg/cm <sup>2</sup> 9 = kPa 10 = torr 11 = MPa 12 = mH <sub>2</sub> O	bar	
Pressure process value status	TUINT8 (bit field)	Bit 0 = Process value invalid (overrange or under-range) Bit 1 = Error in configuration data Bit 2 = Error in calibration data (device is defective)	0	In order to provide a simple way to identify errors, alongside IO-Link's standard troubleshooting functions, a status byte is included in the process data. This signals errors in the sensor and is easy to analyze in the higher-level system. Errors are entered on a bit by bit basis but can also be combined to contain several device errors. ⇒Chapter 6.4
Switching output	TUINT8 (bit field)	Bit 0 = Switching output 1 Bit 1 = Switching output 2	0	0 = Not switched 1 = Switched



## 7.2 Configuration data

The configuration is stored in the parameter manager and is transferred via the IO-Link interface in an acyclic process.

### General

Designation	Index	Subindex	Data type	Value range	Default	Access right <sup>a</sup>	Description
Data format	64	0	TENUM (1 byte)	0 = Floating point 1 = Integer	Floating point	RW	
Pressure process value unit	120	0	TENUM (1 byte)	0 = bar 1 = mbar 2 = ftH <sub>2</sub> O 3 = mmH <sub>2</sub> O 4 = mmHG 5 = psi 6 = inH <sub>2</sub> O 7 = inHG 8 = kg/cm <sup>2</sup> 9 = kPa 10 = torr 11 = MPa 12 = mH <sub>2</sub> O	bar	RW	Main value
Pressure process value offset	121	0	TFLOAT	-9999 to 9999	0	RW	
Pressure filter time constant	122	0	TFLOAT	0 to 100 s	0	RW	
Standard command	2	0	Button	176 = Complete zero point adjustment	-	WO	Sets up the offset value so that the process value is equal to zero.
Standard command	2	0	Button	130 = Reset to default setting	-	WO	The default data is loaded.

<sup>a</sup> RW = Read and write access

RO = Read-only access

WO = Write-only access

# 7 Parameter overview

## Switching output 1 and 2

Designation	Index	Sub-index	Data type	Value range	Default	Access right	Description
Switching behavior	200 and 201	1	TENUM	0 = Inactive 1 = Hysteresis function N/O contact 2 = Hysteresis function N/C contact 3 = Window function N/O contact 4 = Window function N/C contact	Inactive	RW	Index 200 = Switching output 1 Index 201 = Switching output 2
Switching point/Window high	200 and 201	2	TFLOAT	-99999 to 99999	0	RW	
Release point/Window low	200 and 201	3	TFLOAT	-99999 to 99999	0	RW	
Switch-on delay	200 and 201	4	TFLOAT	0 to 100 s	0	RW	
Switch-off delay	200 and 201	5	TFLOAT	0 to 100 s	0	RW	
Output mode	200 and 201	6	TENUM (1 byte)	0 = p-switching 1 = n-switching	P-switching	RW	

## Events

Designation	Index	Sub-index	Data type	Value range	Default	Access right	Description
Event settings	111	0	TUINT8 (bit field)	Bit 0 = Process data invalid Bit 1 = Process data overrange Bit 2 = Process data underrange Bit 3 = Device hardware error	0	RW	0 = Inactive 1 = Active

## 7 Parameter overview

### Fine adjustment data

Designation	Index	Subindex	Data type	Value range	Default	Access right	Description
Active	220	0	TENUM (1 byte)	0 = No 1 = Yes	No	RW	
Actual start value	221	0	TFLOAT	-99999 to 99999	0	RW	
Actual end value	222	0	TFLOAT	-99999 to 99999	0	RW	
Target start value	223	0	TFLOAT	-99999 to 99999	0	RW	
Target end value	224	0	TFLOAT	-99999 to 99999	0	RW	
Standard command	2	0	Button	160 = Set actual start value	-	WO	
Standard command	2	0	Button	161 = Set actual end value	-	WO	



#### NOTE!

The fine adjustment data are not stored in the parameter manager and is transferred via the IO-Link interface in an acyclic process.

# 7 Parameter overview

## 7.3 Service data

The service data is written to the EEPROM in a cyclical process (every 10 minutes) and can be reset via the teach functions.

Designation	Index	Subindex	Data type	Value range	Access right	Description
Operating hours counter	3000	0	TUINT32		RO	
Drag indicator pressure process value min.	3002	0	TFLOAT		RO	
Drag indicator pressure process value max.	3003	0	TFLOAT		RO	
Reset all	3100	0	Device command	1 = Reset	WO	Resets all drag indicators and the operating hours counter
Reset operating hours counter	3100	0	Device command	2 = Reset	WO	
Reset pressure drag indicator min.	3100	0	Device command	3 = Reset	WO	
Reset pressure drag indicator max.	3100	0	Device command	4 = Reset	WO	
VDN version	1000	0	TSTRING	12 byte	RO	
Bootloader version	1001	0	TSTRING	14 byte	RO	

## 8.1 Input

### Measuring range and accuracy

Measuring range (MB) Bar	Linearity <sup>a</sup> % MSP <sup>f</sup>	Accuracy at		Long-term stability <sup>b</sup> % MSP per year	Over-load capacity <sup>c</sup> Bar	Burst pressure Bar	Response of	
		20 °C <sup>d</sup> % MSP	-20 to +80 °C <sup>e</sup> % MSP				MB under-range	MB over-range
-400 to +400 mbar relative pressure	0.3	0.7	2.0	≤0.3	1	1.5	linear up to -1.5 % MSP  Error value: 1·10 <sup>37</sup>	linear up to 5 % MSP  Error value: 2·10 <sup>37</sup>
-1 bar to +1 bar relative pressure	0.3	0.6	1.8	≤0.2	4	8		
-1 bar to +2.5 bar relative pressure	0.3	0.5	1.3		16	24		
-1 bar to +5 bar relative pressure	0.3	0.5	1.2		40	60		
-1 bar to +12 bar relative pressure	0.25	0.5	1.0		100	150		
-1 bar to +30 bar relative pressure	0.2	0.5	1.0		100	150		
-1 bar to +100 bar relative pressure	0.2	0.5	1.0		300	400		
-1 bar to +250 bar relative pressure	0.5	0.7	1.2		500	2000		
-1 bar to +400 bar relative pressure	0.5	0.7	1.2		800	2000		
-1 bar to +600 bar relative pressure	0.5	0.7	1.2		1200	2500		
0 bar to 1 bar absolute pressure	0.3	0.5	1.3	≤0.2	4	6	No detection	
0 bar to 2.5 bar absolute pressure	0.25	0.5	1.2		16	24		
0 bar to 5 bar absolute pressure	0.25	0.5	1.2		40	60		
0 bar to 12 bar absolute pressure	0.25	0.5	1.0		100	150		
0 bar to 30 bar absolute pressure	0.2	0.5	1.0		100	150		
0 bar to 100 bar absolute pressure	0.2	0.5	1.0		400	400		

<sup>a</sup> Linearity according to limit point setting.

<sup>b</sup> Reference conditions EN 61298-1.

<sup>c</sup> All pressure sensors are vacuum proof.

<sup>d</sup> Includes: linearity, hysteresis, repeatability, deviation of measuring range initial value, and measuring range end value.

<sup>e</sup> Includes: linearity, hysteresis, repeatability, deviation of measuring range initial value, measuring range end value, thermal effect on measuring range start, and measuring span.

<sup>f</sup> MSP = measuring span

# 8 Technical data

## Signal processing

Input filter	Digital filter, 2nd order; filter time constant can be set
--------------	--

## Measuring circuit monitoring

Process data invalid	IO-Link event configurable; appears in the process value as an error value
Measuring range overflow	
Measuring range underflow	
Device hardware fault	

## 8.2 Output

Number	1 output in IO-Link operation (IO-Link communication standard version 1.1; see section "Interface ", Page 30) 2 outputs for switch operation (SIO mode; SIO = standard IO)
Switching functions configurable	Hysteresis function or window function N/C or N/O contact Output p switching (PNP) or n switching (NPN) Switch-on/switch-off delay
Switching current	≤100 mA per output
Voltage drop at switching transistor	≤2 V
Short-circuit proof	Yes (clocked)
Reverse polarity protected	Yes
Current limiting	Yes
Hysteresis	
For hysteresis function	Configurable
For window function	Fixed setting (symmetrical; ±0.25 % of the measuring range)
Switch-on, switch-off delay	0 to 100 s
Response time	
Digital switching output	≤ 7 ms
IO-Link	≤ 9 ms

## 8.3 Interface

Communication interface	IO-Link device V 1.1, downward compatible to V 1.0
Data transfer rate (baud rate)	COM 3 (230.4 kBaud)
Max. cable length	20 m, unshielded
Min. cycle time	2 ms
IO Device Description (IODD)	Depending on the ordered input range; available on the website <a href="http://ioddfinder.io-link.com">country.burkert.com</a> or at <a href="http://ioddfinder.io-link.com">http://ioddfinder.io-link.com</a>

## 8.4 Electrical data

Voltage supply	
In IO-Link operation	DC 18 to 32 V
In switch operation	DC 9.6 to 32 V
Nominal voltage	DC 24 V
Current consumption	
In idle mode	≤10 mA
In IO-Link operation	≤12 mA
In switch operation	≤250 mA (with 2 switching outputs)
Electrical safety	Protection rating III according to DIN EN 61140
Intended use	Pressure measurement in industrial plants

The auxiliary energy of the pressure sensor must meet SELV requirements; optionally, an energy-limited current circuit according to section 9.3 of DIN EN 61010-1 and UL 61010-1 can be used.

## 8.5 Mechanical features

Materials	
Sensor	Stainless steel (membrane: 1.4435, welding ring: 1.4404)
High-pressure sensor	Stainless steel 1.4548 (for pressure ranges > 100 bar)
Process connection	Stainless steel 316L (1.4404 or 1.4571)
Housing	Stainless steel 304 (1.4301)
Installation position	Any
Calibration position	Device upright, process connection at the bottom
Weight	Approx. 160 g

# 8 Technical data

## 8.6 Environmental influences

Admissible temperatures	
Medium	-40 °C to +125 °C
Ambient temperature	-40 to +85 °C (Ambient temperature range of the head)
Storage	-40 to +85 °C
Resistance to climatic conditions	
During operation	≤100 % relative humidity without condensation on the outer skin of the device
During storage	≤90 % relative humidity without condensation
Climate class	3K7 according to DIN EN 60721-3-3
Admissible mechanical load	
Vibration resistance	10 g, at 10 to 2000 Hz according to DIN EN 60068-2-6
Shock resistance	20 g for 11 ms according to DIN EN 60068-2-27 50 g for 1 ms according to DIN EN 60068-2-27
Process media	Liquid and gaseous media
Protection type	According to DIN EN 60529
With absolute pressure version	IP65/IP67
With relative pressure version	IP65
Electromagnetic compatibility	According to DIN EN 61326-2-3
Interference emission	Class B <sup>a</sup>
Interference immunity	Industrial requirement

<sup>a</sup> The product is suitable for industrial use as well as for households and small businesses.





**Bürkert SAS**

Rue du Giessen

F-67220 TRIEMBACH-AU-VAL