

Type 8221

Conductivity sensor
Leitfähigkeitssensor
Sonde de conductivité



Operating Instructions

Bedienungsanleitung
Manuel d'utilisation

We reserve the right to make technical changes without notice.
Technische Änderungen vorbehalten.
Sous réserve de modifications techniques.

© Bürkert SAS, 2013 - 2022

Operating Instructions 2201/04_EU-ML_00565354_Original_FR

REF 624533/01

| | |
|--|-----------|
| 1. ABOUT THE OPERATING INSTRUCTIONS | 5 |
| 1.1. Symbols used..... | 5 |
| 1.2. Definition of the word product..... | 5 |
| 2. INTENDED USE | 6 |
| 3. BASIC SAFETY INFORMATION | 6 |
| 4. GENERAL INFORMATION | 7 |
| 4.1. International contacts..... | 7 |
| 4.2. Warranty conditions..... | 7 |
| 4.3. Information on the internet..... | 7 |
| 5. TYPE LABEL | 8 |
| 6. TECHNICAL DATA | 9 |
| 6.1. Conformity to standards and directives..... | 9 |
| 6.2. Conformity to the pressure equipment directive | 9 |
| 6.3. Materials..... | 10 |
| 6.4. General technical data | 11 |
| 6.5. Dimensions..... | 18 |
| 7. INSTALLATION | 18 |
| 7.1. Safety instructions..... | 18 |
| 7.2. Product with clamp connection, and M12 male connector or product with clamp connection, cable and 2 electrodes..... | 19 |
| 7.3. Product with G1 ¼" connection | 22 |
| 7.4. Product with G1", G¾" or NPT¾" connection | 23 |
| 7.5. Product with clamp connection and VarioPin male connector or product with clamp connection, cable and 4 electrodes..... | 24 |
| 7.6. Product with 2" (DN50/40) connection | 26 |
| 7.7. Product with PG13.5 connection | 26 |
| 7.8. Product with PG13.5 connection onto a direct welding holder | 26 |
| 7.9. Product with PG13.5 connection onto a G1 ¼" threaded hygienic holder | 27 |
| 7.10. Product with PG13.5 connection onto a hygienic holder with clamp connection..... | 28 |
| 8. WIRING | 28 |
| 8.1. Product with 4 electrodes and cable, process connection 1½" clamp or G1 ¼"..... | 28 |
| 8.2. Product with 4 electrodes and VarioPin connector, process connection 1½" clamp, 2" clamp or 2" (DN50/40)..... | 29 |
| 8.3. Product with 4 electrodes and PG13.5 connection | 30 |
| 8.4. Product with 2 electrodes and cable..... | 30 |
| 8.5. Product with 2 electrodes and 5-pin M12 male connector..... | 31 |
| 8.6. Product with 4 electrodes and 8-pin M12 male connector..... | 31 |
| 9. CALIBRATION | 32 |
| 9.1. Calibration while the product is disassembled from process | 32 |
| 9.2. Calibration in the process..... | 33 |
| 10. MAINTENANCE AND TROUBLESHOOTING | 33 |
| 10.1. Safety instructions..... | 33 |
| 10.2. Maintenance of the product..... | 34 |

| | |
|---|-----------|
| 11. SPARE PARTS AND ACCESSORIES..... | 34 |
| 12. PACKAGING, TRANSPORT..... | 35 |
| 13. STORAGE..... | 35 |
| 14. DISPOSAL OF THE PRODUCT..... | 35 |

1. ABOUT THE OPERATING INSTRUCTIONS

The Operating Instructions describe the entire life cycle of the product. Please keep the Operating Instructions in a safe place, accessible to all users and any new owners.

The Operating Instructions contain important safety information.

Failure to comply with these instructions can lead to hazardous situations. Pay attention in particular to the chapters "[3. Basic safety information](#)" and "[2. Intended use](#)".

- ▶ Whatever the version of the product, the Operating Instructions must be read and understood.

1.1. Symbols used



DANGER

Warns against an imminent danger.

- ▶ Failure to observe this warning results in death or in serious injury.



WARNING

Warns against a potentially dangerous situation.

- ▶ Failure to observe this warning can result in serious injury or even death.



CAUTION

Warns against a possible risk.

- ▶ Failure to observe this warning can result in substantial or minor injuries.

NOTICE

Warns against material damage.



Indicates additional information, advice or important recommendations.



Refers to information contained in these Operating Instructions or in other documents.

- ▶ Indicates an instruction to be carried out to avoid a danger, a warning or a possible risk.

→ Indicates a procedure to be carried out.

1.2. Definition of the word product

The word "product" used in these Operating Instructions always refers to the conductivity sensor Type 8221.

2. INTENDED USE

Use of the product that does not comply with the instructions could present risks to people, nearby installations and the environment.

The product is intended to measure the electrolytic conductivity of a solution.

- ▶ Use the product only in combination with foreign devices or foreign components recommended or approved by Bürkert.
- ▶ Use the product in compliance with the characteristics and commissioning and use conditions specified in the contractual documents and in the Operating Instructions.
- ▶ Never use the product for security applications.
- ▶ Store, transport, install and operate the product properly.
- ▶ Only operate a product in perfect working order.
- ▶ Only use the product as intended.

3. BASIC SAFETY INFORMATION

This safety information does not take into account any contingencies or occurrences that may arise during installation, use and maintenance of the product.

The operating company is responsible for the respect of the local safety regulations including for the staff safety.



Risk of injury due to high pressure in the installation.

- ▶ Before any intervention on the installation, stop the circulation of fluid, cut off the pressure and drain the pipe.
- ▶ Observe the dependency between the fluid temperature and the fluid pressure. See [Fig. 3](#) chap. 6.4.

Risk of burn injury due to electrical voltage.

- ▶ Observe all applicable accident protection and safety regulations for electrical equipment.

Risk of burn injury due to high fluid temperatures.

- ▶ Do not touch with bare hands the parts of the product that are in contact with the fluid.
- ▶ Before opening the pipe, stop the circulation of fluid and drain the pipe.

Risk of injury due to the nature of the fluid.

- ▶ Respect the prevailing regulations on accident prevention and safety relating to the use of dangerous fluids.



Various dangerous situations.

To avoid injury:

- ▶ Do not use the product in explosive atmospheres.
- ▶ Do not use the product in an environment incompatible with the materials it is made of.
- ▶ Do not use fluid that is incompatible with the materials the product is made of.
- ▶ Do not subject the product to mechanical stress.
- ▶ Do not make any modifications to the product.
- ▶ Prevent any unintentional power supply switch-on.
- ▶ Only qualified and skilled staff can carry out the installation and maintenance work.
- ▶ Guarantee a defined or controlled restarting of the process, after a power supply interruption.
- ▶ Observe the general technical rules.

NOTICE

The product may be damaged by the measured fluid.

- ▶ Systematically check the chemical compatibility of the component materials of the product and the fluids likely to come into contact with the materials (for example: alcohols, strong or concentrated acids, aldehydes, alkaline compounds, esters, aliphatic compounds, ketones, halogenated aromatics or hydrocarbons, oxidants and chlorinated agents).

4. GENERAL INFORMATION

4.1. International contacts

The addresses of our international sales offices are available on the last page of these Operating Instructions.

They are also available on the internet at: country.burkert.com

4.2. Warranty conditions

The condition governing the legal warranty is the conforming use of the product in observance of the operating conditions specified in these Operating Instructions.

4.3. Information on the internet

You can find the Operating Instructions and technical data sheets related to the Type 8221 at: country.burkert.com

5. TYPE LABEL

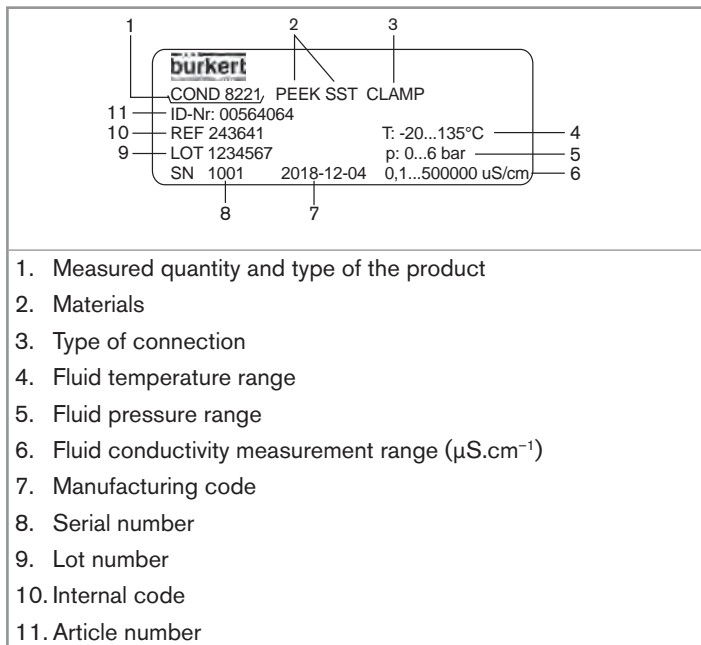

Fig. 1: Type label of a product with 4 electrodes (example)

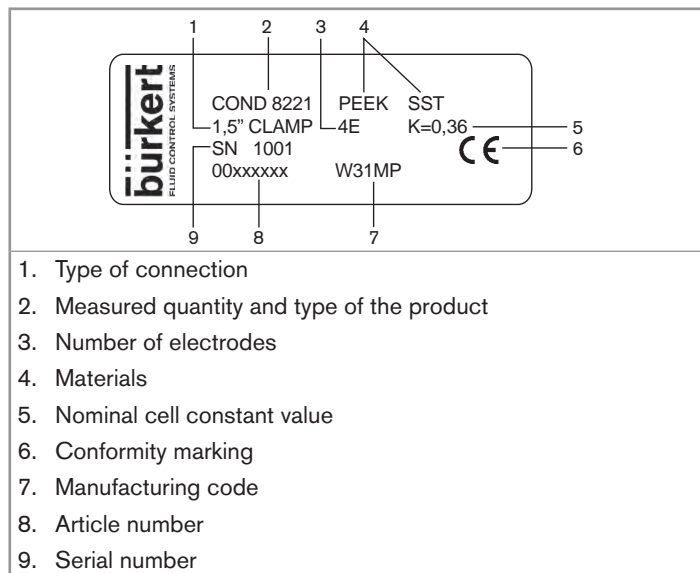

Fig. 2: Type label, lasered, of a product with 4 electrodes (example)

6. TECHNICAL DATA



The Type label of the product gives important technical data.
 ▶ Always respect the data given on the Type label.

6.1. Conformity to standards and directives

The applied standards, which verify conformity with the EU directives, can be found on the EU-type examination certificate and/or the EU declaration of conformity (if applicable).

6.2. Conformity to the pressure equipment directive

- ▶ Make sure that the device materials are compatible with the fluid.
- ▶ Make sure that the pipe DN is adapted for the device.
- ▶ Observe the fluid nominal pressure (PN) for the device. The nominal pressure (PN) is given by the device manufacturer.

The product conforms to Article 4, Paragraph 1 of the Pressure Equipment Directive 2014/68/EU under the following conditions:

- Product used on a pipe (PS = maximum admissible pressure in bar; DN = nominal dimension of the pipe, no unit)

| Type of fluid | Conditions |
|--|---|
| Fluid group 1, Article 4, Paragraph 1.c.i | DN ≤ 25 |
| Fluid group 2, Article 4, Paragraph 1.c.i | DN ≤ 32 or PSxDN ≤ 1000 bar |
| Fluid group 1, Article 4, Paragraph 1.c.ii | DN ≤ 25 or PSxDN ≤ 2000 bar |
| Fluid group 2, Article 4, Paragraph 1.c.ii | DN ≤ 200 or PS ≤ 10 bar or PSxDN ≤ 5000 bar |

- Product used on a vessel (PS = maximum admissible pressure in bar, V = vessel volume in L)

| Type of fluid | Conditions |
|--|--|
| Fluid group 1, Article 4, Paragraph 1.a.i | V > 1 L and PSxV ≤ 25 bar.L or PS ≤ 200 bar |
| Fluid group 2, Article 4, Paragraph 1.a.i | V > 1 L and PSxV ≤ 50 bar.L or PS ≤ 1000 bar |
| Fluid group 1, Article 4, Paragraph 1.a.ii | V > 1 L and PSxV ≤ 200 bar.L or PS ≤ 500 bar |
| Fluid group 2, Article 4, Paragraph 1.a.ii | PS > 10 bar and PSxV ≤ 10000 bar.L or PS ≤ 1000 bar |

6.3. Materials

| Process connection | Electrical connection | Number of electrodes | Materials | | | Surface finish of metallic wetted parts |
|------------------------------|--------------------------|----------------------|-----------------------------|---|---|---|
| | | | Electrodes | Frame | Seal | |
| 1 1/2" clamp | 5-pin M12 male connector | 2 | Stainless steel 316L | Stainless steel 316L PEEK (conform to FDA - 21CFR 177.2415) | EPDM (conform to FDA - 21CFR 177.2600) | Ra<0.4 µm, electro-polished |
| G1" | | | | | | Ra<1.6 µm |
| G3/4" | | | | | | |
| NPT3/4" | | | | | | |
| 1 1/2" clamp | Cable | | Stainless steel | Stainless steel PTFE | EPDM | Ra<0.5 µm |
| 1 1/2" clamp | 8-pin M12 male connector | 4 | Stainless steel 316L | Stainless steel 316L PEEK (conform to FDA - 21CFR 177.2415) | EPDM (conform to FDA - 21CFR 177.2600) | Ra<0.4 µm, electro-polished |
| 1 1/2" clamp, short and long | VarioPin male connector | | Stainless steel 1.4435/316L | Stainless steel 1.4435/316L PEEK (conform to FDA - 21CFR 177.2415) | EPDM (conform to FDA - 21CFR 177.2600) | |
| 1 1/2" clamp, short and long | Cable | | | | | |
| G1 1/4" | | | | | | |
| 2" clamp | | | | | | |
| 2" (DN50/40) ¹⁾ | VarioPin male connector | | | | | |
| PG13.5 | | | | | | |

¹⁾ Adapted for GEA Tuchenhagen VARINLINE process connections

6.4. General technical data

→ Obey the dependency between the liquid temperature and liquid pressure, given in Fig. 3.

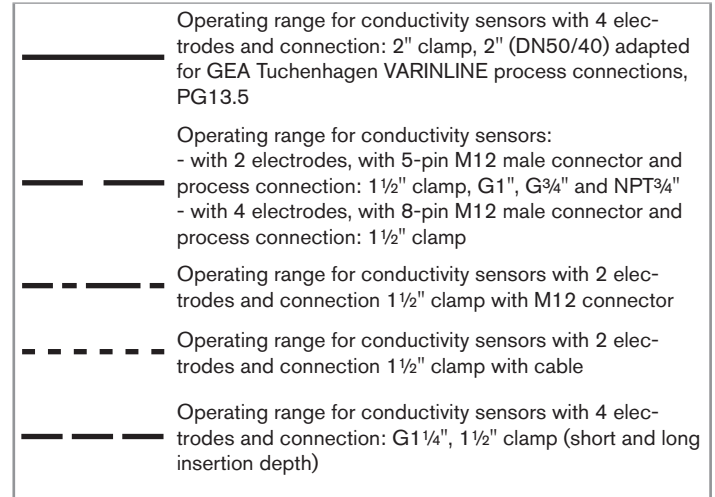
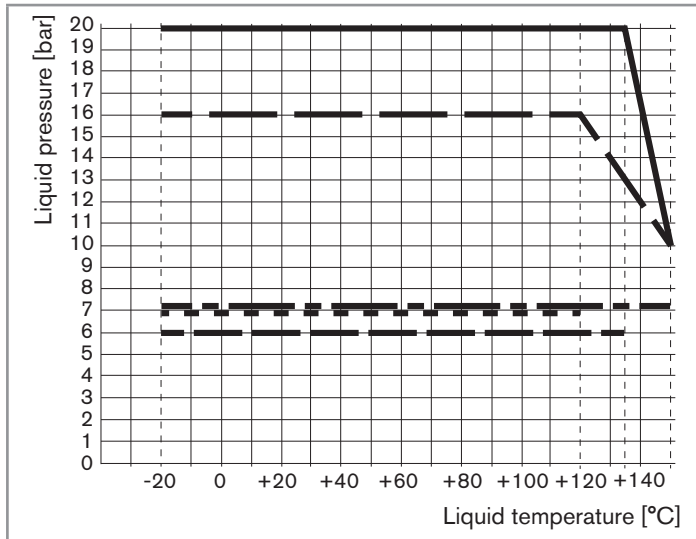



Fig. 3: Liquid temperature / liquid pressure dependency diagram

| | | |
|---|---|--|
|  | <ul style="list-style-type: none"> ▪ 2 electrodes ▪ 1 1/2" clamp connection ▪ 5-pin M12 male connector | |
| Article number | 568818 | 569643 |
| Measurement range | 0.05...20 $\mu\text{S}\cdot\text{cm}^{-1}$ | 1...200 $\mu\text{S}\cdot\text{cm}^{-1}$ |
| Linearity ¹⁾ (relative) | $\pm 0.5...5 \%$ | |
| Cell constant ²⁾ | 0.01 cm^{-1} | 0.1 cm^{-1} |
| Fluid temperature | -20...+150 °C | |
| Fluid pressure | PN16 at -20...+120 °C PN10 at +120...+150 °C | |
| Protection class according to IEC/ EN 60529 | IP67, if the product is wired, inserted and screwed with a 5-pin M12 female cable plug | |
| Temperature sensor | Pt1000 | |
| Electrical connection | 5-pin M12 male connector | |

- 1) *Uncertainty of $\pm 5 \%$ arises when using only one single cell constant for the full range. $\pm 0.5 \%$ measurement deviation can be achieved when calibration is performed in a conductivity range close to that of the used solution.*
- 2) *Nominal cell constant. The cell constant of every product is measured according to a Bürkert standard procedure. The individual cell constant measured is reported in the calibration report, delivered with the product and is reported on the Type label of the product. The cell constant can be influenced by the assembly situation.*

| | | |
|---|---|--|
|  | <ul style="list-style-type: none"> ▪ 4 electrodes ▪ 1 1/2" clamp connection ▪ 8-pin M12 male connector | |
| Article number | 571162 | |
| Measurement range | 1...20000 $\mu\text{S}\cdot\text{cm}^{-1}$ | |
| Linearity ¹⁾ (relative) | $\pm 0.5...5 \%$ | |
| Cell constant ²⁾ | 0.33 cm^{-1} | |
| Fluid temperature | -20...+150 °C | |
| Fluid pressure | PN16 at -20...+120 °C PN10 at +120...+150 °C | |
| Protection class according to IEC/ EN 60529 | IP67, if the product is wired, inserted and screwed with an 8-pin M12 female cable plug | |
| Temperature sensor | Pt1000 | |
| Electrical connection | 8-pin M12 male connector | |

- 1) *Uncertainty of $\pm 5 \%$ arises when using only one single cell constant for the full range. $\pm 0.5 \%$ measurement deviation can be achieved when calibration is performed in a conductivity range close to that of the used solution.*
- 2) *Nominal cell constant. The cell constant of every product is measured according to a Bürkert standard procedure. The individual cell constant measured is reported in the calibration report, delivered with the product and is reported on the Type label of the product. The cell constant can be influenced by the assembly situation.*

Type 8221

Technical data

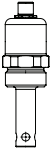
| | | |
|---|--|--|
|  | <ul style="list-style-type: none"> ▪ 2 electrodes ▪ G1" connection ▪ 5-pin M12 male connector | |
| Article number | 569644 | 569645 |
| Measurement range | 0.05...20 $\mu\text{S}\cdot\text{cm}^{-1}$ | 1...200 $\mu\text{S}\cdot\text{cm}^{-1}$ |
| Linearity ¹⁾ (relative) | $\pm 0.5...5 \%$ | |
| Cell constant ²⁾ | 0.01 cm^{-1} | 0.1 cm^{-1} |
| Fluid temperature | -20...+150 °C | |
| Fluid pressure | PN16 at -20...+120 °C PN10 at +120...+150 °C | |
| Protection class according to IEC/ EN 60529 | IP67, if the product is wired, inserted and screwed with a 5-pin M12 female cable plug | |
| Temperature sensor | Pt1000 | |
| Electrical connection | 5-pin M12 male connector | |

- 1) Uncertainty of $\pm 5 \%$ arises when using only one single cell constant for the full range. $\pm 0.5 \%$ measurement deviation can be achieved when calibration is performed in a conductivity range close to that of the used solution.
- 2) Nominal cell constant. The cell constant of every product is measured according to a Bürkert standard procedure. The individual cell constant measured is reported in the calibration report, delivered with the product and is reported on the Type label of the product. The cell constant can be influenced by the assembly situation.

| | | |
|---|---|--|
|  | <ul style="list-style-type: none"> ▪ 2 electrodes ▪ G 3/4" connection ▪ 5-pin M12 male connector | |
| Article number | 570452 | 570453 |
| Measurement range | 0.05...20 $\mu\text{S}\cdot\text{cm}^{-1}$ | 1...200 $\mu\text{S}\cdot\text{cm}^{-1}$ |
| Linearity ¹⁾ (relative) | $\pm 0.5...5 \%$ | |
| Cell constant ²⁾ | 0.01 cm^{-1} | 0.1 cm^{-1} |
| Fluid temperature | -20...+150 °C | |
| Fluid pressure | PN16 at -20...+120 °C PN10 at +120...+150 °C | |
| Protection class according to IEC/ EN 60529 | IP67, if the product is wired, inserted and screwed with a 5-pin M12 female cable plug | |
| Temperature sensor | Pt1000 | |
| Electrical connection | 5-pin M12 male connector | |

- 1) Uncertainty of $\pm 5 \%$ arises when using only one single cell constant for the full range. $\pm 0.5 \%$ measurement deviation can be achieved when calibration is performed in a conductivity range close to that of the used solution.
- 2) Nominal cell constant. The cell constant of every product is measured according to a Bürkert standard procedure. The individual cell constant measured is reported in the calibration report, delivered with the product and is reported on the Type label of the product. The cell constant can be influenced by the assembly situation.

| | | |
|---|---|-----------------------------|
|  | <ul style="list-style-type: none"> 2 electrodes NPT 3/4" connection 5-pin M12 male connector | |
| Article number | 570454 | 570455 |
| Measurement range | 0.05...20 µS.cm ⁻¹ | 1...200 µS.cm ⁻¹ |
| Linearity ¹⁾ (relative) | ±0.5...5 % | |
| Cell constant ²⁾ | 0.01 cm ⁻¹ | 0.1 cm ⁻¹ |
| Fluid temperature | -20...+150 °C | |
| Fluid pressure | PN16 at -20...+120 °C PN10 at +120...+150 °C | |
| Protection class according to IEC/EN 60529 | IP67, if the product is wired, inserted and screwed with a 5-pin M12 female cable plug | |
| Temperature sensor | Pt1000 | |
| Electrical connection | 5-pin M12 male connector | |

- Uncertainty of ±5 % arises when using only one single cell constant for the full range. ±0.5 % measurement deviation can be achieved when calibration is performed in a conductivity range close to that of the used solution.*
- Nominal cell constant. The cell constant of every product is measured according to a Bürkert standard procedure. The individual cell constant measured is reported in the calibration report, delivered with the product and is reported on the Type label of the product. The cell constant can be influenced by the assembly situation.*

| | | | |
|---|--|-----------------------------|------------------------------|
|  | <ul style="list-style-type: none"> 2 electrodes 1 1/2" clamp connection Cable | | |
| Article number | 564898 | 562261 | 564899 |
| Measurement range | 0.05...20 µS.cm ⁻¹ | 1...200 µS.cm ⁻¹ | 5...5000 µS.cm ⁻¹ |
| Linearity ¹⁾ (relative) | ±0.5...5 % | | |
| Cell constant ²⁾ | 0.01 cm ⁻¹ | 0.1 cm ⁻¹ | 1 cm ⁻¹ |
| Fluid temperature | max. +120 °C | | |
| Fluid pressure | max. 7 bar (100 psi) | | |
| Protection class according to IEC/EN 60529 | - | | |
| Temperature sensor | Pt1000 | | |
| Electrical connection | Cable, length 3 m, instrument side with open wire. | | |

- Uncertainty of ±5 % arises when using only one single cell constant for the full range. ±0.5 % measurement deviation can be achieved when calibration is performed in a conductivity range close to that of the used solution.*
- Nominal cell constant. The cell constant of every product is measured according to a Bürkert standard procedure. The individual cell constant measured is reported in the calibration report, delivered with the product. The cell constant can be influenced by the assembly situation.*

Type 8221

Technical data

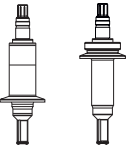
| | |
|---|---|
|  | <ul style="list-style-type: none"> ▪ 4 electrodes ▪ 1 1/2" clamp connection, short or long insertion depth ▪ VarioPin male connector |
| Article number | 562420 (short), 564064 (long) |
| Measurement range | 0.1...500000 $\mu\text{S}\cdot\text{cm}^{-1}$ |
| Linearity ¹⁾ (relative) | $\pm 0.5\text{...}5\%$ |
| Cell constant ²⁾ | 0.147 cm^{-1} |
| Fluid temperature | $-20\text{...}+135\text{ }^\circ\text{C}$ |
| Fluid pressure | max. 6 bar (87 psi) |
| Protection class according to IEC/ EN 60529 | IP67, if the product is wired, inserted and screwed with a VarioPin female connector |
| Temperature sensor | Pt1000 |
| Electrical connection | VarioPin (VP 6.0) male connector |

- 1) *Uncertainty of $\pm 5\%$ arises when using only one single cell constant for the full range. $\pm 0.5\%$ measurement deviation can be achieved when calibration is performed in a conductivity range close to that of the used solution.*
- 2) *Nominal cell constant. The cell constant of every product is measured according to a Bürkert standard procedure. The individual cell constant measured is reported in the calibration report, delivered with the product. The cell constant can be influenced by the assembly situation.*

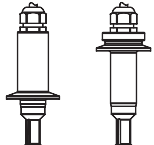
| | |
|--|---|
|  | <ul style="list-style-type: none"> ▪ 4 electrodes ▪ 1 1/2" clamp connection, short or long insertion depth ▪ Cable |
| Article number | 557719 (short), 558884 (long) |
| Measurement range | 0.1...500000 $\mu\text{S}\cdot\text{cm}^{-1}$ |
| Linearity ¹⁾ (relative) | $\pm 0.5\text{...}5\%$ |
| Cell constant ²⁾ | 0.147 cm^{-1} |
| Fluid temperature | $-20\text{...}+135\text{ }^\circ\text{C}$ |
| Fluid pressure | max. 6 bar (87 psi) |
| Protection class according to IEC/ EN 60529 | – |
| Temperature sensor | Pt1000 |
| Electrical connection | High temperature cable, length 5 m, instrument side with open wire. |

- 1) *Uncertainty of $\pm 5\%$ arises when using only one single cell constant for the full range. $\pm 0.5\%$ measurement deviation can be achieved when calibration is performed in a conductivity range close to that of the used solution.*
- 2) *Nominal cell constant. The cell constant of every product is measured according to a Bürkert standard procedure. The individual cell constant measured is reported in the calibration report, delivered with the product. The cell constant can be influenced by the assembly situation.*

| | |
|---|---|
|  | <ul style="list-style-type: none"> ▪ 4 electrodes ▪ G1 1/4" connection ▪ Cable |
| Article number | 562240 |
| Measurement range | 0.1...500000 $\mu\text{S}\cdot\text{cm}^{-1}$ |
| Linearity ¹⁾ (relative) | $\pm 0.5\text{...}5\%$ |
| Cell constant ²⁾ | 0.147 cm^{-1} |
| Fluid temperature | $-20\text{...}+135\text{ }^\circ\text{C}$ |
| Fluid pressure | max. 6 bar (87 psi) |
| Protection class according to IEC/ EN 60529 | – |
| Temperature sensor | Pt1000 |
| Electrical connection | High temperature cable, length 5 m, instrument side with open wire. |

- 1) *Uncertainty of $\pm 5\%$ arises when using only one single cell constant for the full range. $\pm 0.5\%$ measurement deviation can be achieved when calibration is performed in a conductivity range close to that of the used solution.*
- 2) *Nominal cell constant. The cell constant of every product is measured according to a Bürkert standard procedure. The individual cell constant measured is reported in the calibration report, delivered with the product. The cell constant can be influenced by the assembly situation.*

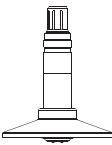
| | |
|--|--|
|  | <ul style="list-style-type: none"> ▪ 4 electrodes ▪ 2" clamp connection ▪ VarioPin male connector |
| Article number | 559120 |
| Measurement range | 1...300000 $\mu\text{S}\cdot\text{cm}^{-1}$ |
| Linearity ¹⁾ (relative) | $\pm 0.5\text{...}5\%$ |
| Cell constant ²⁾ | 0.360 cm^{-1} |
| Fluid temperature | $-20\text{...}+150\text{ }^\circ\text{C}$ |
| Fluid pressure | max. 20 bar (290 psi) at $-20\text{...}+135\text{ }^\circ\text{C}$ max. 10 bar (145 psi) at $+150\text{ }^\circ\text{C}$ |
| Protection class according to IEC/ EN 60529 | IP67, if the product is wired, inserted and screwed with a VarioPin female connector |
| Temperature sensor | Pt1000 |
| Electrical connection | VarioPin (VP 6.0) male connector |

- 1) *Uncertainty of $\pm 5\%$ arises when using only one single cell constant for the full range. $\pm 0.5\%$ measurement deviation can be achieved when calibration is performed in a conductivity range close to that of the used solution.*
- 2) *Nominal cell constant. The cell constant of every product is measured according to a Bürkert standard procedure. The individual cell constant measured is reported in the calibration report, delivered with the product. The cell constant can be influenced by the assembly situation.*

Type 8221

Technical data

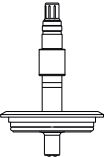
| | |
|---|---|
|  | <ul style="list-style-type: none"> ▪ 4 electrodes ▪ 2" (DN50/40) connection, adapted for GEA Tuchenhagen VARINLINE process connections ▪ VarioPin male connector |
| Article number | 563269 |
| Measurement range | 1...300000 $\mu\text{S}\cdot\text{cm}^{-1}$ |
| Linearity ¹⁾ (relative) | $\pm 0.5\text{...}5\%$ |
| Cell constant ²⁾ | 0.360 cm^{-1} |
| Fluid temperature | -20...+150 °C |
| Fluid pressure | max. 20 bar (290 psi) at -20...+135 °C max. 10 bar (145 psi) at +150 °C |
| Protection class according to IEC/ EN 60529 | IP67, if the product is wired, inserted and screwed with a VarioPin female connector |
| Temperature sensor | Pt1000 |
| Electrical connection | VarioPin (VP 6.0) male connector |

- 1) *Uncertainty of $\pm 5\%$ arises when using only one single cell constant for the full range. $\pm 0.5\%$ measurement deviation can be achieved when calibration is performed in a conductivity range close to that of the used solution.*
- 2) *Nominal cell constant. The cell constant of every product is measured according to a Bürkert standard procedure. The individual cell constant measured is reported in the calibration report, delivered with the product. The cell constant can be influenced by the assembly situation.*

| | |
|---|--|
|  | <ul style="list-style-type: none"> ▪ 4 electrodes ▪ PG13.5 connection ▪ VarioPin male connector |
| Article number | 563186 |
| Measurement range | 0.1...300000 $\mu\text{S}\cdot\text{cm}^{-1}$ |
| Linearity ¹⁾ (relative) | $\pm 0.5\text{...}5\%$ |
| Cell constant ²⁾ | 0.360 cm^{-1} |
| Fluid temperature | -20...+150 °C. max |
| Fluid pressure | max. 20 bar (290 psi) at -20...+135 °C max. 10 bar (145 psi) at +150 °C |
| Protection class according to IEC/ EN 60529 | IP67, if the product is wired, inserted and screwed with a VarioPin female connector |
| Temperature sensor | Pt1000 |
| Electrical connection | VarioPin (VP 6.0) male connector |

- 1) *Uncertainty of $\pm 5\%$ arises when using only one single cell constant for the full range. $\pm 0.5\%$ measurement deviation can be achieved when calibration is performed in a conductivity range close to that of the used solution.*
- 2) *Nominal cell constant. The cell constant of every product is measured according to a Bürkert standard procedure. The individual cell constant measured is reported in the calibration report, delivered with the product. The cell constant can be influenced by the assembly situation.*

6.5. Dimensions

→ Please refer to the technical data sheets related to the product at: country.burkert.com

7. INSTALLATION

7.1. Safety instructions



DANGER

Risk of injury due to high pressure in the installation.

- ▶ Before any intervention on the installation, stop the circulation of fluid, cut off the pressure and drain the pipe.
- ▶ Observe the dependency between the fluid temperature and the fluid pressure. See [Fig. 3](#) chap. [6.4](#).

Risk of burn injury due to electrical voltage.

- ▶ Observe all applicable accident protection and safety regulations for electrical equipment.

Risk of burn injury due to high fluid temperatures.

- ▶ Do not touch with bare hands the parts of the product that are in contact with the fluid.
- ▶ Before opening the pipe, stop the circulation of fluid and drain the pipe.

Risk of injury due to the nature of the fluid.

- ▶ Respect the prevailing regulations on accident prevention and safety relating to the use of dangerous fluids.



WARNING

Risk of injury due to nonconforming installation.

- ▶ The electrical and fluid installation can only be carried out by qualified and skilled staff with the appropriate tools.
- ▶ Respect the assembly instructions for the fitting and/or the holder used.

Risk of injury due to unintentional switch on of power supply or uncontrolled restarting of the installation.

- ▶ Avoid unintentional activation of the installation.
- ▶ Guarantee a set or controlled restarting of the process subsequent to any intervention.

7.2. Product with clamp connection, and M12 male connector or product with clamp connection, cable and 2 electrodes

The chapter describes the installation of the following products:

- products with a 1 1/2" clamp connection, a cable and 2 electrodes. The article numbers are **564898**, **564899** or **562261**;
 - products with a 1 1/2" clamp connection and a 5-pin M12 male connector. The article numbers are **568818** or **569643**;
 - product with a 1 1/2" clamp connection and a 8-pin M12 male connector. The article number is **571162**.
- Install the product in the following ways: onto a pipe (chap. [7.2.1](#)) or on a vessel (chap. [7.2.2](#)).

7.2.1. Installation onto the pipe

- Choose an appropriate tee-fitting for the installation of the product.
- Make sure the seals are in good condition.
- Place seals adapted to the process (temperature, fluid type) in the grooves of the clamp fitting.
- Mount the tee-fitting in the pipe. Obey the mounting instructions given with the fitting.
- Make sure the electrodes will always be completely immersed in the liquid.
- Make sure no air bubbles will disturb the measurements.
- Choose an appropriate clamp collar.
- For the article number **564898** carry out the mounting procedure on [Fig. 4](#).
- For the article number **564899** or **562261** carry out the mounting procedure on [Fig. 5](#).
- For the article number **568818** or **569643** carry out the mounting procedure on [Fig. 4](#) or on [Fig. 5](#).
- For the article number **571162** carry out the mounting procedure on [Fig. 4](#) or on [Fig. 5](#).

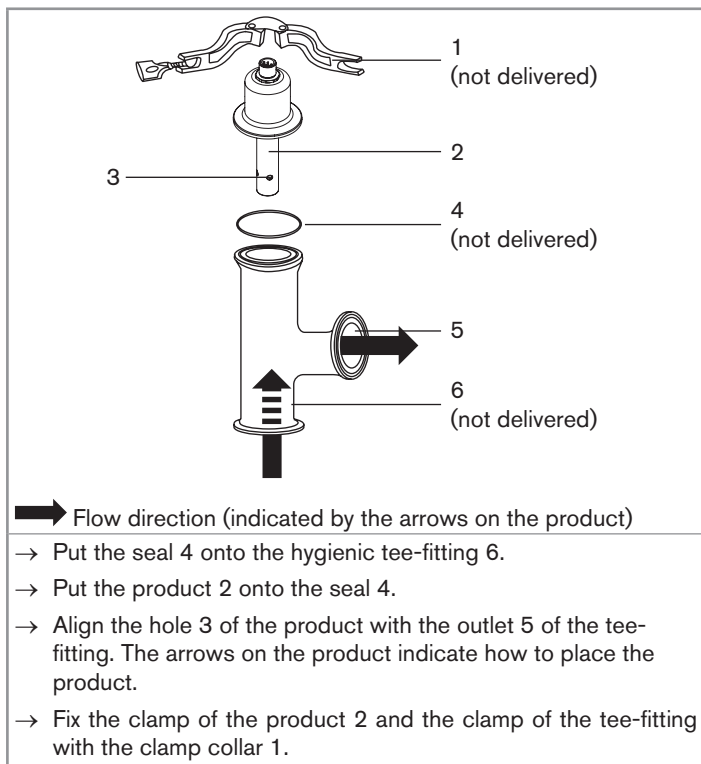

Fig. 4: Installation of a 8221 with article number 564898, 568818, 569643 or 571162 onto a pipe

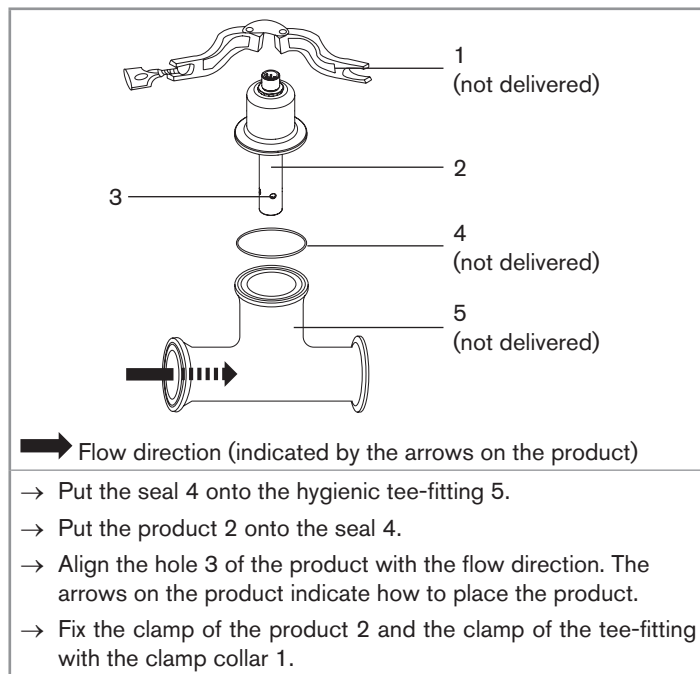

Fig. 5: Installation of a 8221 with article number 564899, 562261, 568818, 569643 or 571162 onto a pipe

7.2.2. Installation on a vessel

- Choose an appropriate fitting for the installation of the product on the vessel.
- Make sure the seals are in good condition.
- Place seals adapted to the process (temperature, fluid type) in the grooves of the clamp fitting.
- Mount the fitting into the vessel. Obey the mounting instructions given with the fitting.
- Make sure the electrodes will always be completely immersed in the liquid.
- Make sure no air bubbles will disturb the measurements.
- Choose an appropriate clamp collar.

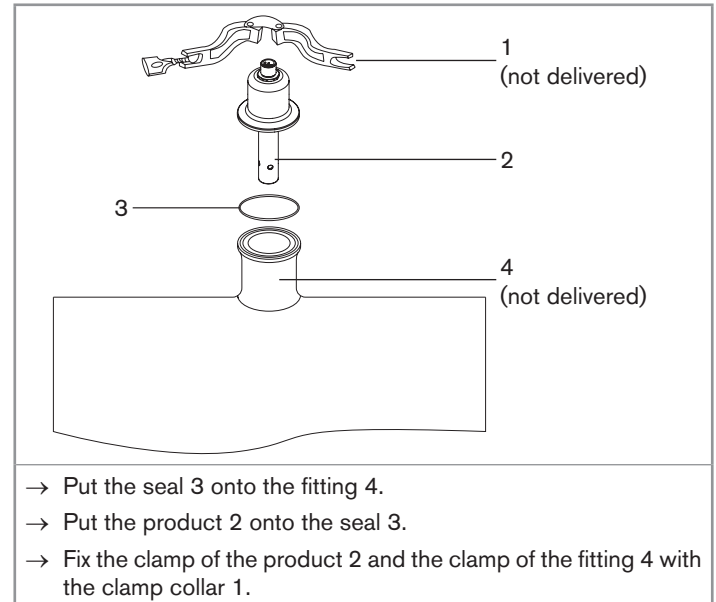

Fig. 6: Installation of a 8221 on a vessel

7.3. Product with G1 1/4" connection

Install the product in the following ways: onto a pipe (chap. [7.3.1](#)) or on a vessel (chap. [7.3.2](#)).

7.3.1. Installation onto the pipe

→ Mount a 1 1/4" weld-in socket, with article number **737241** on the pipe. Obey the instructions given with the weld-in socket.

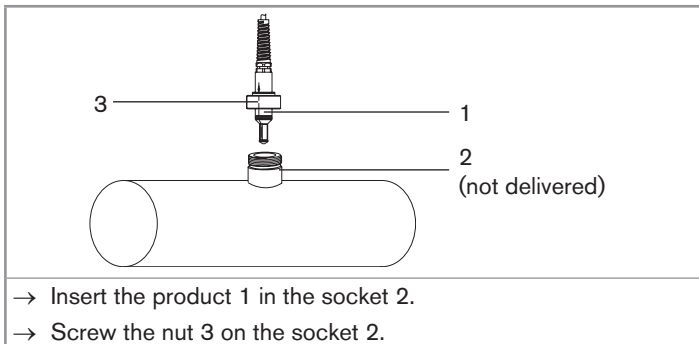

Fig. 7: Installation of a 8221 with a G1 1/4" connection onto a pipe

7.3.2. Installation on a vessel

→ Mount a 1 1/4" weld-in socket, with article number **737241** on the vessel. Obey the instructions given with the weld-in socket.

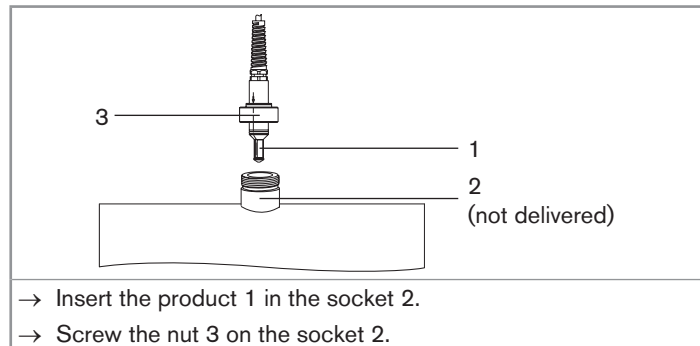

Fig. 8: Installation of a 8221 with a G1 1/4" connection on a vessel

7.4. Product with G1", G^{3/4}" or NPT^{3/4}" connection

Install the product in the following ways: onto a pipe (chap. 7.4.1) or on a vessel (chap. 7.4.2).

For compliance with the PN rating, make sure the complete length of the threaded part (16 mm) is contained in the corresponding weld-in socket, and make sure the seal is correctly compressed.

7.4.1. Installation onto the pipe

→ Mount a weld-in socket with an internal thread of G1", of G^{3/4}" or of NPT^{3/4}" on the pipe. Obey the instructions given with the weld-in socket.

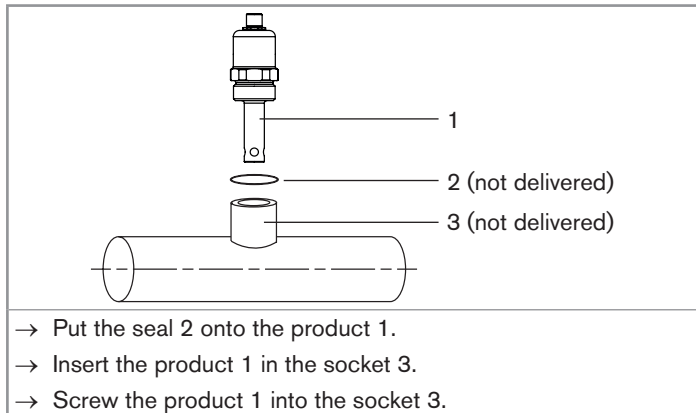

Fig. 9: Installation of a 8221 with a G1", a G^{3/4}" or a NPT^{3/4}" connection onto a pipe

7.4.2. Installation on a vessel

→ Mount a weld-in socket with an internal thread of G1", of G^{3/4}" or of NPT^{3/4}" on the vessel. Obey the instructions given with the weld-in socket.

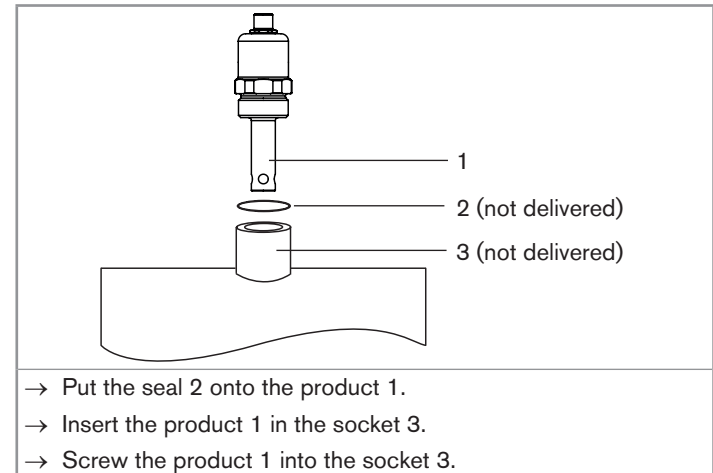

Fig. 10: Installation of a 8221 with a G1", a G^{3/4}" or a NPT^{3/4}" connection on a vessel

7.5. Product with clamp connection and VarioPin male connector or product with clamp connection, cable and 4 electrodes

The chapter describes the installation of the following products:

- products with a 1½" or 2" clamp connection, a cable and a VarioPin male connector. The article numbers of the products are **562420, 564064** or **559120**;
 - products with a 1½" clamp connection, a cable and 4 electrodes. The article numbers of the products are **557719** or **558884**.
- Install the product in the following ways: onto a pipe (chap. [7.5.1](#)) or on a vessel (chap. [7.5.2](#)).

7.5.1. Installation onto the pipe

- Make sure the process connection is clean. Clean it if necessary.
- Obey the following recommendations when installing the product.



The cell constant and the linearity of the product may vary depending on the mounting position. A symmetrical setup is recommended:

- ▶ Leave a minimum clearance of 60 mm around the product.
- ▶ Use connection pieces made of non-conductive materials.

To achieve high precision the cell constant should be calibrated in the final setup:

- ▶ Make sure all 4 electrodes are completely and continuously immersed in the measuring sample.



Fig. 11: Placing the product onto the pipe

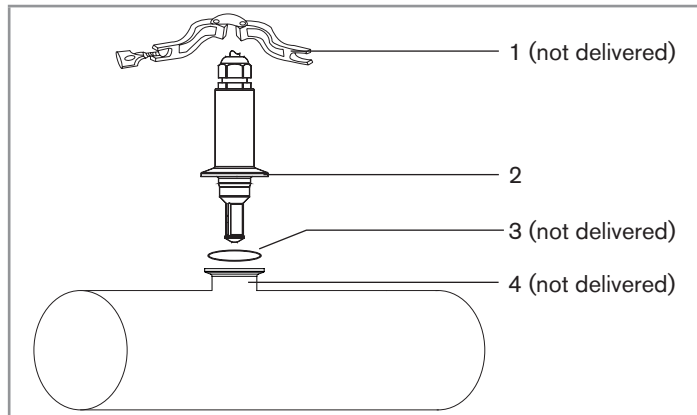

Type 8221

Installation

- Make sure the seal 3 is on the product 2.
- Install product 2 with clamp connection onto the clamp 4 of the pipe and put them together.
- Fix the clamps with the clamp collar 1.

Fig. 12: Installation of a 8221 with article number 562420, 564064, 559120, 557719 or 558884 onto a pipe

7.5.2. Installation on a vessel

- Make sure the process connection is clean. Clean it if necessary.
- Obey the following recommendations when installing the product.



The cell constant and the linearity of the product may vary depending on the mounting position. A symmetrical setup is recommended:

- ▶ Leave a minimum clearance of 60 mm around the product.
- ▶ Use connection pieces made of non-conductive materials.

To achieve high precision the cell constant should be calibrated in the final setup:

- ▶ Make sure all 4 electrodes are completely and continuously immersed in the measuring sample.

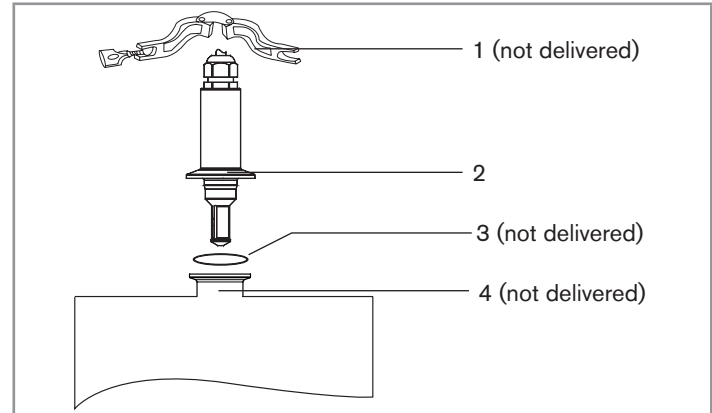

- Make sure the seal 3 is on the product 2.
- Install product 2 with clamp connection onto the clamp 4 of the vessel and put them together.
- Fix the clamps with the clamp collar 1.

Fig. 13: Installation of a 8221 with article number 562420, 564064, 559120, 557719 or 558884 on a vessel

7.6. Product with 2" (DN50/40) connection

The product with a 2" (DN50/40) connection is mounted onto the GEA Tuchenhagen VARINLINE process connections to the appropriate dimensions.

7.7. Product with PG13.5 connection

The product with a PG13.5 connection is mounted onto a holder of the following types:

- 8200 direct welding holder (see chap. [7.8](#));
- 8200 hygienic holder with G1 1/4" threaded connection (see chap. [7.9](#));
- 8200 hygienic holder with clamp connection (see chap. [7.10](#)).



To install the holder, refer to the Operating Instructions of the direct welding holder Type 8200 or to the Operating Instructions of the hygienic holder Type 8200.

7.8. Product with PG13.5 connection onto a direct welding holder



The holder is only intended for the mounting of products with a length of 120 mm.



Make sure the welded area has cooled down before inserting the product.

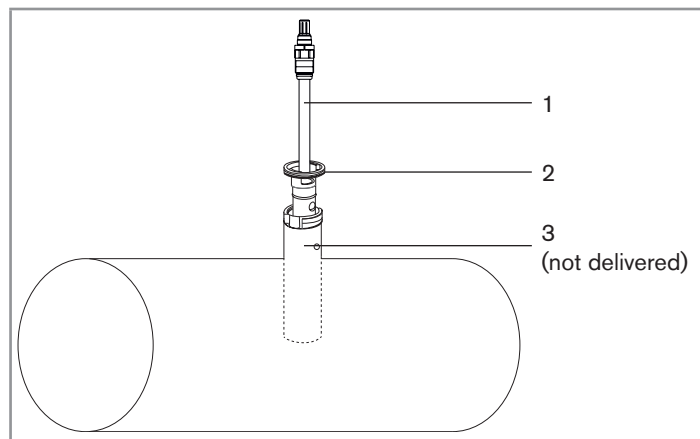

Type 8221 Installation

- Make sure the direct welding holder is mounted onto the pipe or on the vessel.
- Make sure the product and the holder are not damaged.
- Make sure all O-rings are in place in their appropriate grooves, and are not damaged.
- Insert the seal pusher 2 into the holder 3.
- Screw the product 1 into the seal pusher 2 using a tightening torque of 2...3 N·m (1.48...2.21 lbf·ft).

Fig. 14: Installation of a 8221 with a PG13.5 connection onto a direct welding holder onto a pipe or on a vessel

7.9. Product with PG13.5 connection onto a G1 1/4" threaded hygienic holder



- ▶ To avoid any mechanical damage to O-rings during assembly, lightly grease them.
- ▶ After assembly, clean the product of any remaining drops of grease.

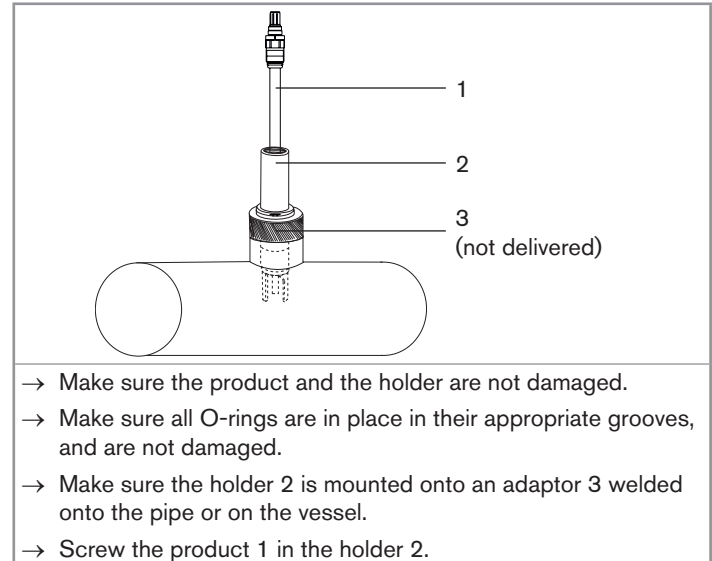
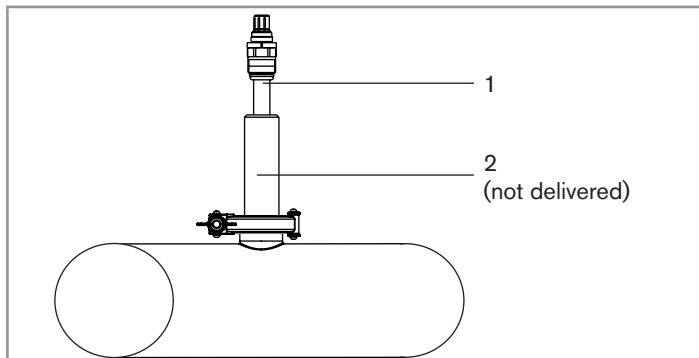

Fig. 15: Installation of a 8221 with a PG13.5 connection onto a holder with G1 1/4" connection onto a pipe or on a vessel

7.10. Product with PG13.5 connection onto a hygienic holder with clamp connection



- ▶ To avoid any mechanical damage to O-rings during assembly, lightly grease them.
- ▶ After assembly, clean the product of any remaining drops of grease.



- Make sure the product and the holder are not damaged.
- Make sure all O-rings are in place in their appropriate grooves, and are not damaged.
- Make sure the holder 2 is fixed onto the clamp of the pipe or onto the clamp of the vessel.
- Screw the product 1 in the holder 2.

Fig. 16: Installation of a 8221 with a PG13.5 connection onto a holder with clamp connection onto a pipe or on a vessel

8. WIRING

8.1. Product with 4 electrodes and cable, process connection 1 ½" clamp or G1 ¼"

| Signal description | Cable colour | Bürkert controller Type 8619 |
|--------------------------------|--------------|------------------------------|
| Pt1000 (low end) | grey | 7 SE |
| Pt1000 | white | 8 TS |
| Pt1000 | blue | 9 TS |
| Current electrode (high end) | pink | 1 C+ |
| Potential electrode (high end) | green | 2 P+ |
| Potential electrode (low end) | brown | 3 P- |
| Current electrode (low end) | yellow | 4 C- |
| Not connected on product | shield | 6 FE |
| Not connected | red | - |

8.2. Product with 4 electrodes and VarioPin connector, process connection 1 1/2" clamp, 2" clamp or 2" (DN50/40)

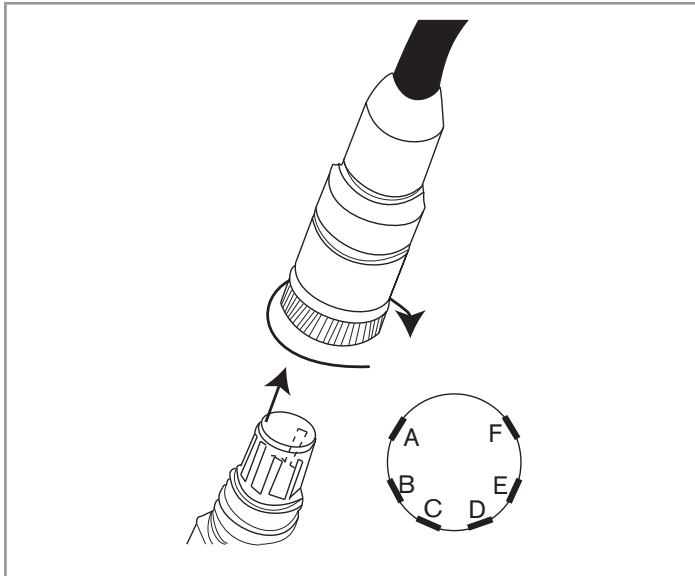

Fig. 17: Pins of the VarioPin connector

| Signal description | VarioPin * | | Bürkert controller Type 8619 |
|--------------------------------|------------|--------------|---------------------------------------|
| | Pin | Cable colour | |
| Pt1000 | E | white | 9 TS |
| Pt1000 | F | green | 7 SE |
| Current electrode (high end) | B | red | 1 C+ |
| Potential electrode (high end) | A | transparent | 2 P+ |
| Potential electrode (low end) | C | grey | 3 P- |
| Current electrode (low end) | D | blue | 4 C- |
| Not connected on product | shield | green/yellow | 6 FE |
| | | | PLEASE NOTE: → short 7 SE and 8 TS |

* The cable colours are only valid for the Bürkert VarioPin connection cables with article number: **554855, 554856, 554857.**

8.3. Product with 4 electrodes and PG13.5 connection

| Signal description | VarioPin* | | Bürkert controller Type 8619 |
|--------------------------------|-----------|--------------|---------------------------------------|
| | Pin | Cable colour | |
| Pt1000 | E | white | 9 TS |
| Pt1000 | F | green | 7 SE |
| Current electrode (high end) | B | red | 1 C+ |
| Potential electrode (high end) | A | transparent | 2 P+ |
| Potential electrode (low end) | C | grey | 3 P- |
| Current electrode (low end) | D | blue | 4 C- |
| Not connected on product | shield | green/yellow | 6 FE |
| - | | | PLEASE NOTE: → short 7 SE and 8 TS |

* The cable colours are only valid for the Bürkert VarioPin connection cables with article number: **554855**, **554856**, **554857**.

8.4. Product with 2 electrodes and cable

| Signal description | Cable colour | Bürkert controller Type 8619 |
|--------------------------------|--------------|--|
| Pt1000 | red | 9 TS |
| Pt1000 | green | 7 SE |
| Potential electrode (low end) | white | 3 P- |
| Potential electrode (high end) | black | 2 P+ |
| Shield | transparent | 6 FE |
| - | | PLEASE NOTE: → short 7 SE and 8 TS → short 2 P+ et 1 C+ → short 3 P- and 4 C- |

8.5. Product with 2 electrodes and 5-pin M12 male connector

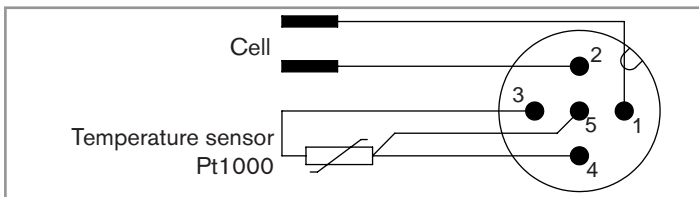

Fig. 18: 5-pin M12 male connector, pin assignment

→ To connect the product to a device Type 8619, obey the instructions given in the Operating Instructions Type 8619 and in Fig. 19.

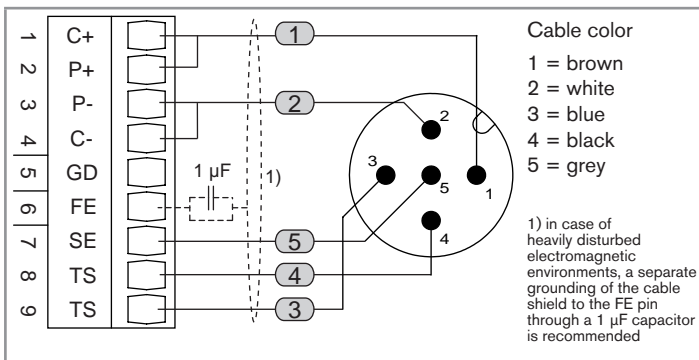

Fig. 19: Wiring the product with 2 electrodes and a 5-pin M12 male connector to the device Type 8619

8.6. Product with 4 electrodes and 8-pin M12 male connector

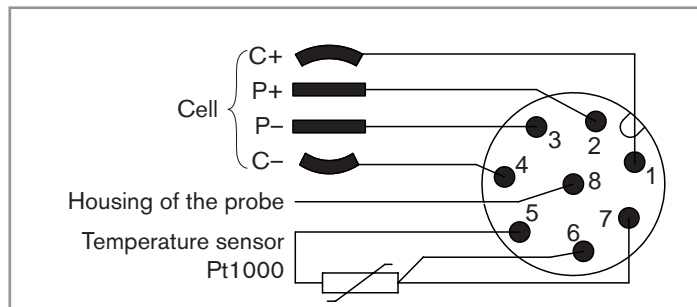

Fig. 20: 8-pin M12 male connector, pin assignment

→ To connect the product to a device Type 8619, obey the instructions given in the Operating Instructions Type 8619 and in Fig. 21.

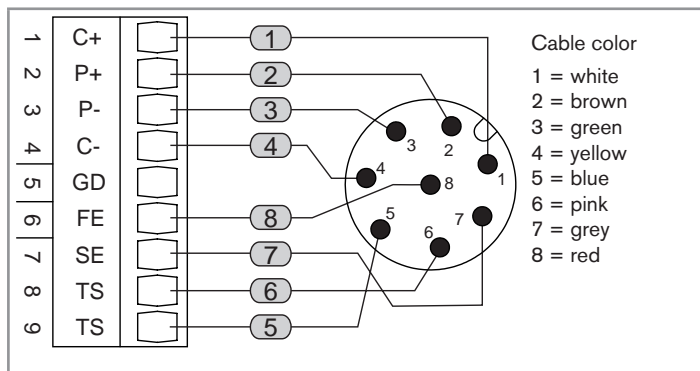

Fig. 21: Wiring the product with 4 electrodes and an 8-pin M12 male connector to the device Type 8619

9. CALIBRATION

There are 2 possible calibration procedures:

- calibration while the product is disassembled from process;
- calibration in the process.

9.1. Calibration while the product is disassembled from process

For precise determination of the cell constant, it is recommended that you do the calibration procedure in the conditions that are similar to the process conditions. The cell constant may vary according to the final mounting position in the process.

- Rinse the product thoroughly with deionized water.
- Use a beaker with an internal diameter of at least 60 mm. (The product can be directly immersed into the Bürkert conductivity standard calibration solutions).
- Use a solution of known conductivity (see chapter [11](#), page [34](#)).
- Make sure the temperature of the solution is measured and stable.
- Immerse the product in the calibration solution.
Make sure the surfaces of all electrodes (2 or 4, depending on the version) are completely immersed and free of gas and free of air bubbles. The product should be placed in the center of the beaker.
- Leave the product in the solution for at least 5 minutes for equilibration, before initiating the calibration on the instrument.

9.2. Calibration in the process

- Insert the product in the process.
- Leave conductivity and temperature at least 15 minutes for equilibration.
- Take a process sample and do a measurement with a reference conductivity meter. Do the measurement at a temperature equal to that of the process. If that is not possible, you need to know the temperature compensation coefficient of your sample.
- Manually adjust the cell constant to read the same conductivity value on the process instrument.



You may switch off the temperature compensation of the process to prevent any errors. Refer to the Operating Instructions of the device connected to the product.

10. MAINTENANCE AND TROUBLESHOOTING

10.1. Safety instructions



DANGER

Risk of injury due to high pressure in the installation.

- ▶ Before any intervention on the installation, stop the circulation of fluid, cut off the pressure and drain the pipe.
- ▶ Observe the dependency between the fluid temperature and the fluid pressure. See [Fig. 3](#) chap. 6.4.

Risk of burn injury due to electrical voltage.

- ▶ Observe all applicable accident protection and safety regulations for electrical equipment.

Risk of burn injury due to high fluid temperatures.

- ▶ Do not touch with bare hands the parts of the product that are in contact with the fluid.
- ▶ Before opening the pipe, stop the circulation of fluid and drain the pipe.

Risk of injury due to the nature of the fluid.

- ▶ Respect the prevailing regulations on accident prevention and safety relating to the use of dangerous fluids.



WARNING

Risk of injury due to non-conforming maintenance.

- ▶ Maintenance must only be carried out by qualified and skilled staff with the appropriate tools.
- ▶ Ensure that the restart of the installation is controlled after any interventions.

10.2. Maintenance of the product

The product can be cleaned with a cloth dampened with water or a detergent compatible with the materials the product is made of.

Please feel free to contact your Bürkert supplier for any additional information.



Check the O-rings at regular intervals.

- ▶ Replace the O-rings if their condition is not satisfactory.

11. SPARE PARTS AND ACCESSORIES



CAUTION

Risk of injury and/or damage caused by the use of unsuitable parts.

Incorrect accessories and unsuitable replacement parts may cause injuries and damage the product and the surrounding area.

- ▶ Use only original accessories and original replacement parts from Bürkert.

| Accessories | Article number |
|---|----------------|
| Calibration solution, 5 $\mu\text{S}\cdot\text{cm}^{-1}$ conductivity standard, ± 1 % accuracy, 300 ml | 440015 |
| Calibration solution, 15 $\mu\text{S}\cdot\text{cm}^{-1}$ conductivity standard, ± 5 % accuracy, 300 ml | 440016 |
| Calibration solution, 100 $\mu\text{S}\cdot\text{cm}^{-1}$ conductivity standard, ± 3 % accuracy, 300 ml | 440017 |
| Calibration solution, 706 $\mu\text{S}\cdot\text{cm}^{-1}$ conductivity standard, ± 2 % accuracy, 300 ml | 440018 |
| Calibration solution, 1413 $\mu\text{S}\cdot\text{cm}^{-1}$ conductivity standard, ± 1 % accuracy, 300 ml | 440019 |
| Calibration solution, 100 $\mu\text{S}\cdot\text{cm}^{-1}$ conductivity standard, ± 1 % accuracy, 300 ml | 440020 |
| Connection cable VarioPin (VP 6.0), female connector, 3 meters | 554855 |

| Accessories | Article number |
|--|----------------|
| Connection cable VarioPin (VP 6.0), female connector, 5 meters | 554856 |
| Connection cable VarioPin (VP 6.0), female connector, 10 meters | 554857 |
| Straight 5-pin M12 female cable-plug with plastic threaded locking-ring, to be wired | 917116 |
| Straight 5-pin M12 female cable-plug moulded on cable (2 meters, shielded) | 438680 |
| Straight 5-pin M12 female cable-plug moulded on cable (5 meters, shielded) | 560365 |
| Straight 5-pin M12 female cable-plug moulded on cable (10 meters, shielded) | 563108 |
| Straight 8-pin M12 female cable-plug with plastic threaded locking-ring, to be wired | 444799 |
| Straight 8-pin M12 female cable-plug moulded on cable (2 meters, shielded) | 444800 |
| Straight 8-pin M12 female cable-plug moulded on cable (5 meters, shielded) | 555675 |

12. PACKAGING, TRANSPORT

NOTICE

Damage due to transport

Transport may damage an insufficiently protected part.

- ▶ Transport the product in shock-resistant packaging and away from humidity and dirt.
- ▶ Do not expose the product to temperatures that may exceed the admissible storage temperature range.

13. STORAGE

NOTICE

Poor storage can damage the product.

- ▶ Store the product in a dry place away from dust.

14. DISPOSAL OF THE PRODUCT

→ Dispose of the product and its packaging in an environmentally-friendly way.

NOTICE

Damage to the environment caused by parts contaminated by fluids.

- ▶ Comply with the national and/or local regulations which concern the area of waste disposal.

www.burkert.com