

Type 8030 HT - SE30 HT

High Temperature

Flowmeter with paddle wheel
and flow transmitter



Operating Instructions

Bedienungsanleitung
Manuel d'utilisation

We reserve the right to make technical changes without notice.

Technische Änderungen vorbehalten.

Sous réserve de modification technique.

www.burkert.com

© Bürkert SAS, 2013–2022

Operating Instructions 2201/03_EU-ML 00449752 / Original EN

1.	ABOUT THESE OPERATING INSTRUCTIONS	3
2.	INTENDED USE	6
3.	BASIC SAFETY INFORMATION.....	7
4.	GENERAL INFORMATION	10
5.	DESCRIPTION	11
6.	TECHNICAL DATA	14
7.	INSTALLATION AND COMMISSIONING	19
8.	MAINTENANCE	33
9.	ACCESSORIES	35
10.	PACKAGING, TRANSPORT	36
11.	STORAGE	36
12.	DISPOSAL OF THE DEVICE	37

1. ABOUT THESE OPERATING INSTRUCTIONS

The Operating Instructions describe the entire life cycle of the device. Please keep the Operating Instructions in a safe place, accessible to all users and any new owners.

The Operating Instructions contain important safety information.

Failure to comply with these instructions can lead to hazardous situations. Pay attention in particular to the chapters [3. Basic safety information](#) and [2. Intended use](#).

- ▶ Whatever the version of the device, the Operating Instructions must be read and understood.

Symbols used



DANGER

Warns against an imminent danger.

- ▶ Failure to observe this warning can result in death or in serious injury.



WARNING

Warns against a potentially dangerous situation.

- ▶ Failure to observe this warning can result in serious injury or even death.



CAUTION

Warns against a possible risk.

- ▶ Failure to observe this warning can result in substantial or minor injuries.

NOTE

Warns against material damage.



Indicates additional information, advice or important recommendations.



Refers to information contained in these Operating Instructions or in other documents.

- ▶ Indicates an instruction to be carried out to avoid a danger, a warning or a possible risk.
- Indicates a procedure to be carried out.

Definition of the word "device"

The word "device" used within these Operating Instructions refers to the flowmeter type 8030 HT or to the flow transmitter type SE30 HT (high temperature).

2. INTENDED USE

Use of the device that does not comply with the instructions could present risks to people, nearby installations and the environment.

The M3030 HT flowmeter and the SE30 HT flow transmitter are intended exclusively to measure flow rate in liquids.

- ▶ The device must be protected against electromagnetic interference, ultraviolet rays and, when installed outdoors, the effects of climatic conditions.
- ▶ The device must be used in compliance with the characteristics and commissioning and use conditions specified in the contractual documents and in the Operating Instructions.
- ▶ Requirements for the safe and proper operation of the device are proper transport, storage and installation, as well as careful operation and maintenance.
- ▶ Only use the device as intended.

3. BASIC SAFETY INFORMATION

This safety information does not take into account any contingencies or occurrences that may arise during installation, use and maintenance of the device.

The operating company is responsible for the respect of the local safety regulations including for the staff safety.



- Danger due to high pressure in the installation.
- Danger due to electrical voltage.
- Danger due to high temperatures of the fluid.
- Danger due to the nature of the fluid.



Various dangerous situations

- ▶ Prevent any unintentional power supply switch-on.
- ▶ Ensure that installation and maintenance work are carried out by qualified, authorised personnel in possession of the appropriate tools.



Various dangerous situations

- ▶ Guarantee a set or controlled restarting of the process, after a power supply interruption.
- ▶ Use the device only if in perfect working order and in compliance with the instructions provided in the Operating Instructions.
- ▶ Observe the general technical rules when installing and using the device.
- ▶ Do not use the device in explosive atmospheres.
- ▶ Do not use the device for the measurement of gas flow rates.
- ▶ Do not use fluid that is incompatible with the materials the device is made of.
- ▶ Do not use the device in an environment incompatible with the materials it is made of.
- ▶ Do not subject the device to mechanical loads.
- ▶ Do not make any external or internal modifications to the device.

NOTE

The device may be damaged by the fluid in contact with

- ▶ Systematically check the chemical compatibility of the component materials of the device and the fluids likely to come into contact with them (for example: alcohols, strong or concentrated acids, aldehydes, alkaline compounds, esters, aliphatic compounds, ketones, halogenated aromatics or hydrocarbons, oxidants and chlorinated agents).

NOTE

Elements / Components sensitive to electrostatic discharges

The device contains electronic components sensitive to electrostatic discharges. They may be damaged if they are touched by an electrostatically charged person or object. In the worst case scenario, these components are instantly destroyed or go out of order as soon as they are activated.

- ▶ To minimise or even avoid all damage due to an electrostatic discharge, take all the precautions described in standard EN 61340-5-1.
- ▶ Do not touch any of the live electrical components.

4. GENERAL INFORMATION

To contact the manufacturer of the device, use following address:

Bürkert SAS

Rue du Giessen

BP 200

F-67220 TRIEMBACH-AU-VAL

You may also contact your local Bürkert sales office.

The addresses of our international sales offices are available on the internet at: country.burkert.com.

Warranty conditions

The condition governing the legal warranty is the conforming use of the device in observance of the operating conditions specified in these Operating Instructions.

Information on the Internet

You can find the Operating Instructions and technical data sheets regarding the type 8030 HT at: country.burkert.com.

5. DESCRIPTION

Area of application

The S030 HT flowmeter and the SE30 HT flow transmitter are intended to measure the flow rate of neutral or slightly aggressive liquids free of solid particles.

Construction

The device is built with an SE30 HT flow transmitter and an S030 HT sensor-fitting incorporating the measuring element.

The transmitter can be removed without opening the piping or stopping the process. Depending on the version, the device is fitted with:

- 2 pulse outputs, NPN and PNP, or
- 1 sinus output.

Electrical connection is made via a male fixed connector.

MAN 1900320015 EN version: C 3

Measuring principle

The fluid flowing in the piping makes the paddle-wheel turn. The sensor detects the rotation of the paddle-wheel thus generating a signal whose frequency f is proportional to the flow rate Q , acc. to formula:

- $f = 1000 \cdot K \cdot Q$ for a version with 2 pulse outputs,
- $f = 1900 \cdot K \cdot Q$ for a version with 1 sinus output,

f = frequency in Hertz (Hz)

K = K factor specific to each sensor-fitting S030 HT, in pulse/litre

Q = flow rate in litre/second

Description of the name plate (example)

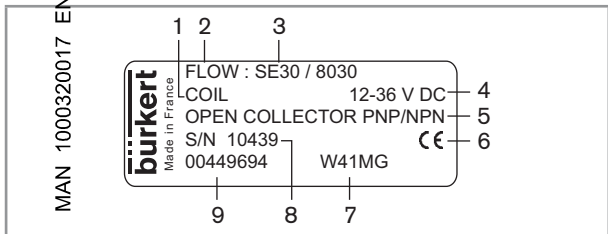

1. Type of flow sensor
2. Measured quantity
3. Type of the device
4. Supply voltage
5. Output data
6. Conformity marking
7. Manufacturing code
8. Serial number
9. Order code

6. TECHNICAL DATA

Conditions of use

Ambient temperature (operating)	<ul style="list-style-type: none">• Version with pulse outputs: -15 °C...+80 °C• Version with sinus output: -15 °C...+100 °C
Air humidity	< 80 %, non condensated
Protection rating acc. to EN 60529	IP65, female connector wired, plugged and tightened

Conformity to standards and directives

The applied standards, which verify conformity with the EU Directives, can be found on the EU Type Examination Certificate and/or the EU Declaration of Conformity (if applicable).

Conformity to the Pressure Equipment Directive

- Make sure that the device materials are compatible with the fluid.
- Make sure that the pipe DN is adapted for the device.
- Observe the fluid nominal pressure (PN) for the device. The nominal pressure (PN) is given by the device manufacturer.

The device conforms to Article 4, Paragraph 1 of the Pressure Equipment Directive 2014/68/EU under the following conditions:

- Device used on a pipe (PS = maximum admissible pressure, in bar; DN = nominal dimension of the pipe, no unit)

Type of fluid	Conditions
Fluid group 1, Article 4, Paragraph 1.c.i	$DN \leq 25$
Fluid group 2, Article 4, Paragraph 1.c.i	$DN \leq 32$ or $PS \times DN \leq 1000$ bar
Fluid group 1, Article 4, Paragraph 1.c.ii	$DN \leq 25$ or $PS \times DN \leq 2000$ bar
Fluid group 2, Article 4, Paragraph 1.c.ii	$DN \leq 200$ or $PS \leq 10$ bar or $PS \times DN \leq 5000$ bar

Fluid data

Fluid pressure	Depends on the fluid temperature: refer to the Operating Instructions of the sensor-fitting used.
Fluid temperature	-15 °C...+125 °C The fluid temperature may be restricted by the fluid pressure: refer to the Operating Instructions of the sensor-fitting S030 HT.
Type and data of the fluid	refer to the Operating Instructions of the sensor-fitting used.
Flow rate measurement	
• Measurement range	• 0.5...10 m/s
• Measurement deviation	
- K-factor standard	- ± 2.5 % of the measured value*
- Teach-In	- ± 1 % of the measured value* (at the value of the Teach-In flow rate)
• Linearity	• ± 0.5 % of the full scale (10 m/s)
• Repeatability	• ± 0.4 % of the measured value*

* Determined in the following reference conditions: medium = water, water and ambient temperatures 20 °C, min. upstream and downstream distances respected, appropriate pipe dimensions.

Materials

Part	Material
Housing	PPS, glass fibre reinforced
Male fixed connector	PA
Female connector type 2511 / screw / seal	PA / Stainless steel / NBR
Identification label	Polyester
Sensor-fitting S030 HT	Refer to the Operating Instructions of the sensor-fitting used.

Electrical data

Version with pulse outputs	
Supply voltage	12...36 V DC, filtered and regulated
Current consumption	10 mA max.
Protection against polarity reversal	Yes
Protection against spike voltages	Yes

MAN 10082007 EN version: C 3

Version with pulse outputs	
Protection against short circuits	Yes
NPN and PNP, 700 mA max., frequency up to 250 Hz, duty cycle 1/2 ±10 % NPN output: 0.2...30 V DC PNP output: supply voltage	
Version with sinus output	
Supply voltage	Without
Frequency up to 500 Hz, about 2.8 mV peak-to-peak/Hz under a 50 kΩ load	

7. INSTALLATION AND COMMISSIONING

Safety instructions



DANGER

Risk of injury due to high pressure in the installation.

- ▶ Stop the circulation of fluid, cut off the pressure and drain the pipe before loosening the process connections.

Risk of burning due to high fluid temperatures.

- ▶ Use safety gloves to handle the device.
- ▶ Stop the circulation of fluid and drain the pipe before loosening the process connections.

Risk of injury due to the nature of the fluid.

- ▶ Respect the prevailing regulations on accident prevention and safety relating to the use of hazardous products.



DANGER

Risk of injury due to electrical voltage.

- ▶ If the device is installed either in a wet environment or outdoors, all the electrical voltages must be of max. 35 V DC.
- ▶ Shut down and isolate the electrical power source before carrying out work on the system.
- ▶ Observe all applicable accident protection and safety regulations for electrical equipment.



WARNING

Risk of injury due to non-conforming installation.

- ▶ The electrical and fluid installation can only be carried out by qualified and skilled staff with the appropriate tools.
- ▶ Observe mounting instructions of the fitting.

Risk of injury due to an uncontrolled restart.

- ▶ Ensure that the restart of the installation is controlled after any interventions on it.



WARNING

Risk of injury if the fluid pressure/temperature dependency is not respected.

- ▶ Take account of fluid temperature-pressure dependency according to the nature of the materials the fitting is made of (see the technical data and the Operating Instructions of the fitting used).
- ▶ Comply with the Pressure Equipment Directive 2014/68/EU.



WARNING

Risk of injury due to nonconforming commissioning.
 Non conforming commissioning may lead to injuries and damage the device and its surroundings.

- ▶ Before commissioning, make sure that the staff in charge have read and fully understood the contents of the Operating Instructions.
- ▶ In particular, observe the safety recommendations and intended use.
- ▶ The device / the installation must only be commissioned by suitably trained staff.

NOT

Version: C 3
EN
10002507

Risk of damage to the device due to the environment

- ▶ Protect this device against electromagnetic interference, ultraviolet rays and, when installed outdoors, the effects of the climatic conditions.



To make sure the device operates correctly, plug in and tighten the connector.

Installation onto the pipe

- Choose a fitting appropriate to the velocity and the flow rate of the fluid inside the pipe, refer to the following graphs (see [Tab. 1](#)). The graph is used to determine the DN of the pipe and the fitting appropriate to the application, according to the fluid velocity and the flow rate.
- Install the fitting on the pipe as described in the Operating Instructions of the fitting used.

MAN 10002301
E1
Version: C 3

Example:

- Specification:

- Nominal flow: 10 m³/h,
- Optimal flow velocity: 2...3 m/s

- Solution: intersection between flow rate and flow velocity in the graph gives the appropriate pipe diameter, DN40 (or DN50 for the asterisked fittings).

* For the fittings:

- with external thread connections acc. to SMS 1145,
- with welding end connections acc. to SMS 3008, BS 4825-1 / ASME BPE / DIN 11866 series C, DIN 11850 series 2 / DIN 11866 series A / EN 10357 series A
- Clamp connections acc. to SMS 3017, BS 4825-3 / ASME BPE, DIN 32676 series A



The names of the following norms have changed in the Operating Instructions:

- For the welding ends, norm BS 4825 is renamed BS 4825-1;
- For the clamp connections, norm BS 4825 is renamed BS 4825-3.



The norm for the clamp connections DIN 32676 series A has been added.

Tab.

Version: C 3

Diagram flow/ rate / fluid velocity/ DN of sensor-fitting S030 HT

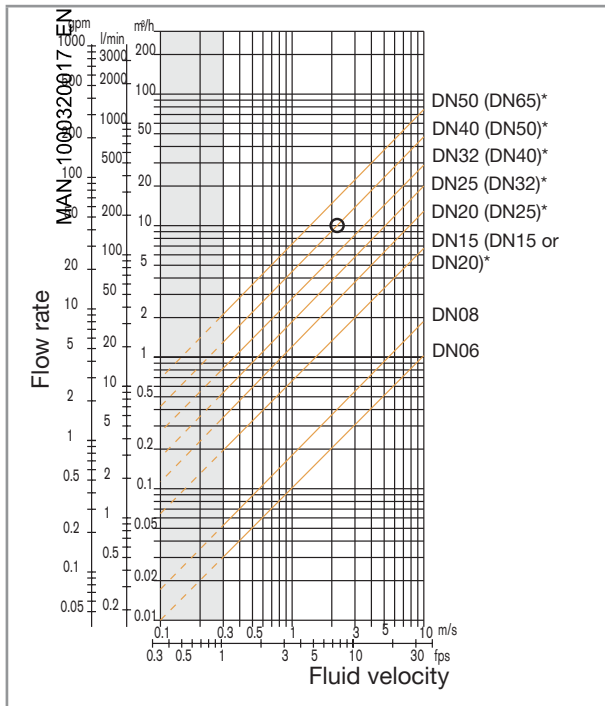

- Assemble the electronic module and the sensor-fitting according to [Fig. 1](#).

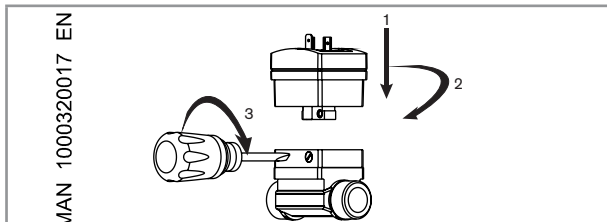

Fig. 1: Assembling the SE30 HT and the sensor-fitting S030 HT

Wiring



DANGER

Risk of injury due to electrical discharge

- ▶ If the device is installed either in a wet environment or outdoors, all the electrical voltages must be of max. 35 V DC.
- ▶ Shut down and isolate the electrical power source before carrying out work on the system.
- ▶ Observe all applicable accident protection and safety regulations for electrical equipment.



Protect the power supply

- ▶ Protect the power supply with a correctly rated fuse if it is not protected by default.
- ▶ Use a shielded cable with an operating temperature limit higher than +80 °C.
- ▶ Use a high quality electrical power supply (filtered and regulated).

Electrical connection is made via a male fixed connector by a female connector type 2518 or type 2509.

Specifications of the connection cables

Specification of the cables and the conductors (not supplied)	Recommended value
Shielded cable	Yes
Length of the cable	Max. 50 m
External diameter of the cable	5...8 mm
Operating temperature	Min. 80 °C
Cross section of the local earth conductor	Min. 0.75 mm ²
Cross section of the conductors, except the local earth conductor	0.2...1.5 mm ²

Tab. 2: *Specifications of the cables and wires for the female connector type 2518 with order code 00572264 (supplied), or the female connector type 2509 with order code 00162673 (not supplied)*

Assembling the female connector

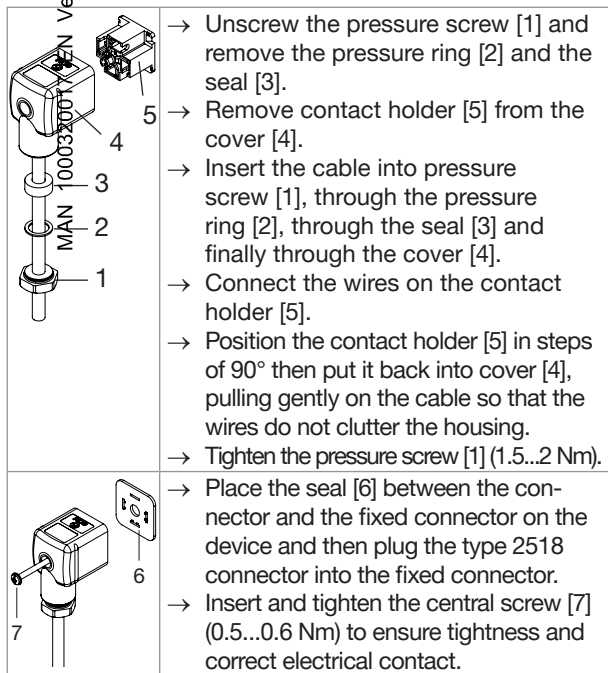

Fig. 2: Assembling the female connector type 2518 (supplied)

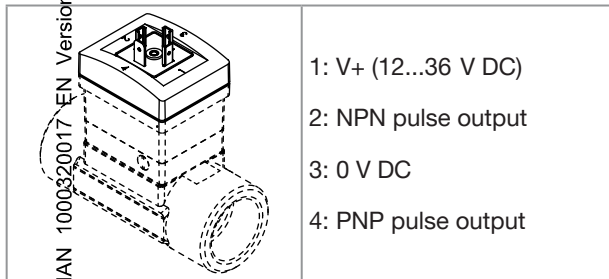

Fig. 3: Pin assignment of the fixed connector, version with pulse outputs

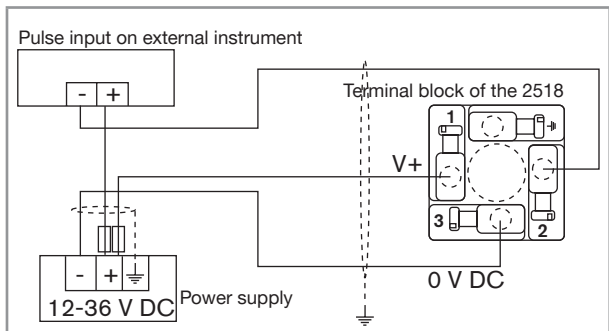

Fig. 4: NPN wiring of the version with pulse outputs

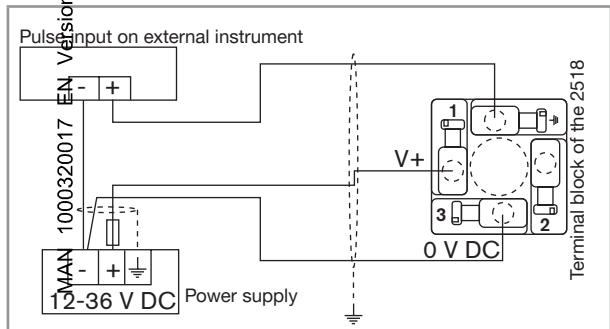

Fig. 5: PNP wiring of the version with pulse outputs

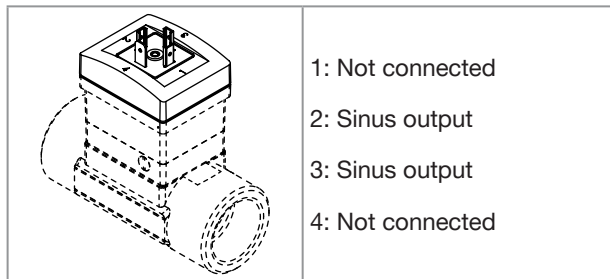

Fig. 6: Pin assignment of the fixed connector, version with sinus output

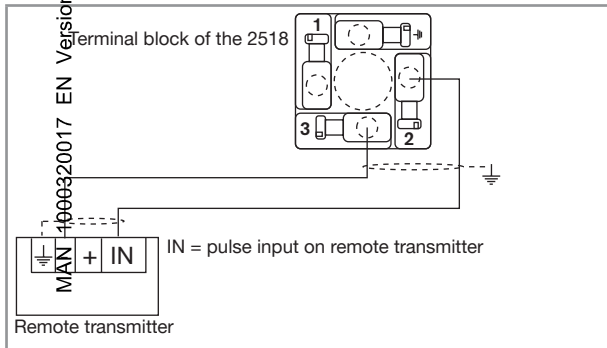

Fig. 7: Wiring of the version with sinus output

8. MAINTENANCE

Safety instructions



DANGER

Risk of injury due to electrical voltage.

- ▶ If the device is installed either in a wet environment or outdoors, all the electrical voltages must be of max. 35 V DC.
- ▶ Shut down and isolate the electrical power source before carrying out work on the system.
- ▶ Observe all applicable accident protection and safety regulations for electrical equipment.

Risk of injury due to high pressure in the installation.

- ▶ Stop the circulation of fluid, cut off the pressure and drain the pipe before loosening the process connections.

Risk of burning due to high fluid temperatures.

- ▶ Use safety gloves to handle the device.
- ▶ Stop the circulation of fluid and drain the pipes before loosening the process connections.
- ▶ Keep all easily flammable material and fluid away from the device.



DANGER

Risk of injury due to the nature of the fluid.

- ▶ Respect the prevailing regulations on accident prevention and safety relating to the use of aggressive fluids.



WARNING

Risk of injury due to non-conforming maintenance.

- ▶ Maintenance must only be carried out by qualified and skilled staff with the appropriate tools.
- ▶ Ensure that the restart of the installation is controlled after any interventions.

Cleaning the device

→ The device can be cleaned with a cloth dampened with water or a detergent compatible with the materials the device is made of.

Please feel free to contact your Bürkert supplier for any additional information.

9. ACCESSORIES



CAUTION

Risk of injury and/or damage caused by the use of unsuitable parts.

Incorrect accessories and unsuitable spare parts may cause injuries and damage the device and the surrounding area.

- ▶ Use only original accessories and original spare parts from Bürkert.

Accessories	Order code
Female connector with cable gland (type 2518)	572264
Female connector (type 2509) with NPT 1/2" reduction, without cable gland	162673

10. PACKAGING, TRANSPORT

CAUTION

Damage due to transport

Transport may damage an insufficiently protected device.

- ▶ Transport the device in shock-resistant packaging and away from humidity and dirt.
- ▶ Do not expose the device to temperatures that may exceed the admissible storage temperature range.
- ▶ Protect the electrical interfaces using protective plugs.

11. STORAGE

CAUTION

Poor storage can damage the device.

- ▶ Store the device in a dry place away from dust.
- ▶ Storage temperature:
 - Version with pulse outputs: $-15\text{ °C} \dots +80\text{ °C}$
 - Version with sinus output: $-15\text{ °C} \dots +100\text{ °C}$

12. DISPOSAL OF THE DEVICE

→ Dispose of the device and its packaging in an environmentally-friendly way.

NOTE

Damage to the environment caused by parts contaminated by the fluid.

- ▶ Comply with the national and/or local regulations which concern the area of waste disposal.