

Type 8694 REV.2

Positioner Top Control Basic

Electropneumatic position controller



We reserve the right to make technical changes without notice.
Technische Änderungen vorbehalten.
Sous réserve de modifications techniques.

© Bürkert Werke GmbH & Co. KG, 2018 - 2026

Operating Instructions 2603/06_EN-EN_00815304 / Original DE

Positioner Type 8694 REV.2

TABLE OF CONTENTS

1	ABOUT THESE INSTRUCTIONS	8
1.1	Symbols.....	8
1.2	Definition of terms.....	9
1.3	Firmware changes.....	9
2	INTENDED USE	10
3	BASIC SAFETY INSTRUCTIONS	11
4	GENERAL INFORMATION	12
4.1	Contact address.....	12
4.2	Warranty	12
4.3	Trademarks.....	12
4.4	Information on the internet.....	12
5	SYSTEM DESCRIPTION	13
5.1	Intended application area.....	13
5.2	Function of the positioner and combination with valve types	13
5.3	Features of the valve types.....	14
5.4	Structure of the positioner.....	15
5.4.1	Representation	15
5.4.2	Features	16
5.4.3	Function diagram of the positioner with single-acting actuator	17
5.5	Type 8694 positioner (position controller).....	18
5.5.1	Schematic representation of the position control Type 8694	18
5.5.2	Functions of the position controller software	19
5.6	Interfaces of the positioner	21
6	TECHNICAL DATA	22
6.1	Conformity.....	22
6.2	Standards	22
6.3	Licenses	22
6.4	Operating conditions	22

6.5	Mechanical data.....	22
6.6	Pneumatic data	23
6.7	Type labels	23
6.7.1	Type label.....	23
6.7.2	UL additional label	23
6.8	Electrical data	24
6.8.1	Electrical data, without fieldbus communication.....	24
6.8.2	Electrical data, IO-Link	25
6.8.3	Electrical data, bÜS.....	25
6.8.4	Electrical data, AS-Interface	25
6.9	Factory settings of the positioner	26
7	CONTROL AND DISPLAY ELEMENTS	27
7.1	Operating state.....	27
7.2	Control and display elements of the positioner.....	27
7.3	Configuration of the buttons.....	29
7.4	Function of the DIP switches	31
7.5	Display of the LEDs	33
7.5.1	Device status display.....	33
7.5.2	Status LED, green.....	35
7.6	Error messages.....	36
7.6.1	Messages for device status „Out of specification“	36
7.6.2	Messages: Actuator moves to safety position	36
8	INSTALLATION.....	38
8.1	Safety instructions	38
8.2	Installation of the positioner Type 8694 on process valves of series 2103, 2300 and 2301...38	
8.3	Installing the positioner Type 8694 on process valves belonging to series 26xx and 27xx.....	41
8.4	Installation on rotary actuators from third party manufacturers.....	45
8.5	Rotating the actuator module.....	46
8.6	Rotating the positioner for process valves belonging to series 26xx and 27xx	47
9	PNEUMATIC INSTALLATION.....	49
9.1	Safety instructions	49

- 9.2 Connecting the device pneumatically..... 49
- 9.3 Manual actuation of the actuator via pilot valves..... 50
 - 9.3.1 Single-acting actuators (control function A and B)..... 50
- 10 ELECTRICAL INSTALLATION WITHOUT FIELDBUS..... 52
 - 10.1 Safety instructions 52
 - 10.2 Electrical installation with circular plug-in connector 52
 - 10.2.1 Designation of the contacts Type 8694 52
 - 10.2.2 Connection of the positioner Type 8694..... 53
 - 10.3 Electrical installation with cable gland..... 55
- 11 ELECTRICAL INSTALLATION, IO-LINK..... 58
- 12 ELECTRICAL INSTALLATION, BÜS 59
- 13 ELEKTRICAL INSTALLATION, AS-INTERFACE 60
 - 13.1 Connecting the device with multi-pole cable and flat cable terminal 60
- 14 START-UP 62
 - 14.1 Safety instructions 62
 - 14.2 Specifying the standard settings 62
 - 14.2.1 Running the automatic adjustment **X.TUNE** 62
 - 14.3 Setting with Bürkert Communicator..... 64
 - 14.3.1 Connecting IO-Link device with Bürkert Communicator..... 64
 - 14.3.2 Connecting büS device with Bürkert Communicator 65
- 15 IO-LINK..... 66
 - 15.1 Information, IO-Link 66
 - 15.2 Technical specifications, IO-Link 66
 - 15.2.1 Configuration of the fieldbus 66
- 16 BÜS..... 67
 - 16.1 Information, büS..... 67
 - 16.2 Configuration of the fieldbus 67
- 17 AS-INTERFACE..... 68
 - 17.1 Information, AS-Interface 68

17.2	Length of the bus line	68
17.3	Technical data for AS-Interface PCBs	68
17.4	Programming data	68
17.5	LED status display AS-Interface	69
18	OPERATION AND FUNCTION	71
18.1	Basic functions	71
18.1.1	DIR.CMD - Reversal of the effective direction of the positioner set-point value	72
18.1.2	CUTOFF - Sealing function for the positioner.....	73
18.1.3	CHARACT - Characteristic correction between input signal (position set-point value) and stroke	74
18.1.4	INPUT - Enter the standard signal.....	76
18.1.5	RESET - Reset to factory settings.....	77
18.1.6	X.TUNE - Automatic calibration of the position controller.....	77
18.2	Auxiliary functions	78
18.2.1	DIR.ACT - Reversal of the effective direction of the actuator	79
18.2.2	SPLTRNG - Signal split range	80
18.2.3	X.LIMIT - Stroke limit.....	81
18.2.4	X.TIME - Limit actuating time	82
18.2.5	X.CONTROL - Control parameters of the positioner	83
18.2.6	SAFPOS - Definition of the safe position	83
18.2.7	SIG.ERROR - Configuration of cable break detection (only for variant without fieldbus communication)	84
18.2.8	BINARY.IN (variant) - Configuration of the digital input (only for variant without fieldbus communication)	84
18.2.9	OUTPUT (variant) - Configuration of the analog output (only for variant without fieldbus communication)	85
18.2.10	Setting the LED mode, device status	85

19	SAFETY END POSITIONS	86
	19.1 Safety end positions after failure of the electrical or pneumatic auxiliary power	86
20	MAINTENANCE	87
	20.1 Safety instructions	87
	20.2 Service at the air intake filter	88
21	ACCESSORIES	89
	21.1 Communications software	89
22	DISASSEMBLY	90
	22.1 Safety instructions	90
	22.2 Disassembly the positioner	90
23	TRANSPORTATION, STORAGE, DISPOSAL	92

1 ABOUT THESE INSTRUCTIONS

The operating instructions describe the entire life cycle of the device.

→ Keep these instructions ready to hand at the operation site.

Important safety information.

- ▶ Carefully read these instructions.
- ▶ Observe in particular the safety instructions, intended use and operating conditions.
- ▶ Persons, who work on the device, must read and understand these instructions.

1.1 Symbols



DANGER

Warns of an immediate danger.

- ▶ Failure to observe the warning will result in a fatal or serious injury.



WARNING

Warns of a potentially dangerous situation.

- ▶ Failure to observe the warning may result a fatal or serious injury.



CAUTION

Warns of a possible danger.

- ▶ Failure to observe the warning may result in moderate or minor injuries.

NOTE

Warns of damage to property.

- ▶ Failure to observe the warning may result in damage to device or system.



Indicates important additional information, tips and recommendations.



Refers to information in these operating instructions or in other documentation.

- ▶ Indicates an instruction for risk prevention.

→ Indicates a procedure which you must carry out.



Indicates a result.

Menu Indicates a interface text.

1.2 Definition of terms

In these instructions the term “device” denotes the following device types:

Positioner Type 8694 REV.2

The term “bÜS” (Bürkert system bus) used in this instruction stands for the communication bus developed by Bürkert and based on the CANopen protocol.

In these instructions, the abbreviation “Ex” always refers to “potentially explosive atmosphere”.

1.3 Firmware changes

As of firmware version	Changes
A.1.6	Display of “valve position half-way“ changed from “LED off“ to “LED is lit white

2 INTENDED USE

The Positoner Type 8694 REV.2 is designed to be mounted on pneumatic actuators of process valves for the control of media. The permitted fluid media are listed in the technical data.

- ▶ Use the device for its intended purpose only. Non-intended use of the device may be dangerous to people, nearby equipment and the environment.
- ▶ Correct transportation, correct storage as well as correct installation, commissioning, operation and maintenance are essential for reliable and problem-free operation.
- ▶ When using the device, observe the permitted data, operating conditions and application conditions. This information can be found in the contractual documents, the operating instructions and on the type label.
- ▶ Use the device only in conjunction with third-party devices and components recommended and authorized by Bürkert.
- ▶ Do not use the device outdoors without protection from the weather.
- ▶ In potentially explosive atmosphere, only use devices approved for use in those areas. These devices are labeled with a separate Ex type label. For such use, note the information provided on the separate Ex type label and the additional explosion-related information or separate explosion-related operating instructions.
- ▶ Do not remove the operating and display elements from the device.

3 BASIC SAFETY INSTRUCTIONS

These safety instructions do not consider any contingencies or incidents which occur during installation, operation and maintenance.

The operator is responsible for observing the location-specific safety regulations, also with reference to the personnel.

DANGER

Risk of injury from high pressure and discharge of medium.

- ▶ Before working on the device or system, switch off the pressure. Vent or drain lines.

DANGER

Risk of injury from electric shock.

- ▶ Before working on the device or system, switch off the power supply. Secure against reactivation.
- ▶ Observe applicable accident prevention and safety regulations for electrical equipment.



To prevent injury, ensure the following:

- ▶ Secure device or system to prevent unintentional activation.
- ▶ Only trained technicians may perform installation and maintenance work.
- ▶ Perform installation and maintenance with suitable tools only.
- ▶ Do not make any changes to the device and do not subject it to mechanical stress.
- ▶ Operate the device only in perfect state and in consideration of the operating instructions.
- ▶ Observe the general rules of technology.
- ▶ Install the device according to the regulations applicable in the respective country.
- ▶ Do not feed corrosive or flammable media into the device connections.
- ▶ Do not feed any fluids into the connections of the device.
- ▶ After the process is interrupted, restart in a controlled manner. Observe sequence:
 1. Connect electrical or pneumatic power supply.
 2. Charge the device with medium.
- ▶ Observe intended use.

NOTE

Electrostatic sensitive components or modules.

The device contains electronic components, which react sensitively to electrostatic discharge (ESD). Contact with electrostatically charged persons or objects is hazardous to these components. In the worst case scenario, they will be destroyed immediately or will fail after start-up.

- ▶ Observe the requirements in accordance with EN 61340-5-1 and to minimize or avoid the possibility of damage caused by sudden electrostatic discharge.
- ▶ Also ensure that you do not touch electronic components when the power supply is on.

4 GENERAL INFORMATION

4.1 Contact address

Germany

Bürkert Fluid Control System
Sales Center
Chr.-Bürkert-Str. 13-17
D-74653 Ingelfingen
Tel. + 49 (0) 7940 - 10 91 111
Fax + 49 (0) 7940 - 10 91 448
E-mail: info@burkert.com

International

Contact addresses can be found on the final pages of the printed operating instructions.

And also on the Internet at:

www.burkert.com

4.2 Warranty

The warranty is only valid if the positioner Type 8694 is used as intended in accordance with the specified application conditions.

4.3 Trademarks

Brands and trademarks listed below are trademarks of the corresponding companies / associations / organizations

Loctite Henkel Loctite Deutschland GmbH

4.4 Information on the internet

The operating instructions and data sheets for Type 8694 can be found on the Internet at:

www.burkert.com

5 SYSTEM DESCRIPTION

5.1 Intended application area

The positioner Type 8694 is designed to be mounted on pneumatic actuators of process valves for the control of media.

5.2 Function of the positioner and combination with valve types

Positioner Type 8694 is an electropneumatic position controller for pneumatically actuated control valves with single-acting actuators.

Together with the pneumatic actuator, the positioner forms a functional unit.

The control valve systems can be used for a wide range of control tasks in fluid technology and, depending on the application conditions, different process valves belonging to series 2103, 2300, 2301, 26xx or 27xx from the Bürkert range can be combined with the positioner. Angle-seat valves, diaphragm valves or ball valves fitted with a control cone are suitable.

“Figure 1” shows an overview of the possible combinations of positioner and different pneumatically actuated valves. Different actuator sizes and valve nominal widths, not illustrated here, are available for each type. More precise specifications can be found on the respective data sheets. The product range is being continuously expanded.

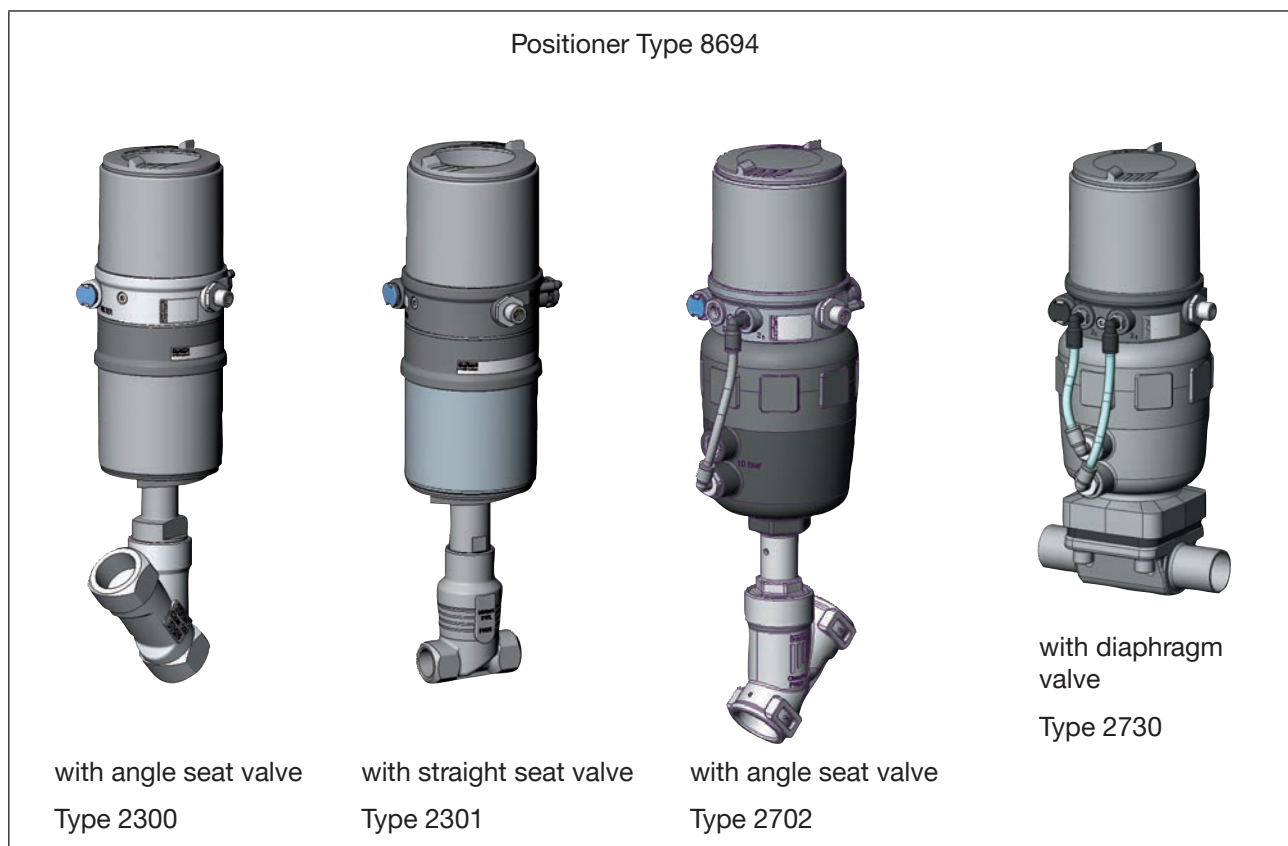

Figure 1: Overview of possible combinations

The position of the actuator is regulated according to the position set-point value. The position set-point value is specified by an external standard signal.

Pneumatically actuated piston actuators and rotary actuators can be used as an actuator. Single-acting actuators are offered in combination with the positioner.

For single-acting actuators, only one chamber is aerated and deaerated in the actuator. The generated pressure works against a spring. The piston moves until there is an equilibrium of forces between compressive force and spring force.

5.3 Features of the valve types

	Angle seat control valves / straight seat control valves	Diaphragm valves	Ball valves	Flap valves
Types	<ul style="list-style-type: none"> • 2300 • 2301 • 2702 • 2712 	<ul style="list-style-type: none"> • 2103 • 2730 • 2731 	<ul style="list-style-type: none"> • 2652 • 2655 • 2658 	<ul style="list-style-type: none"> • 2672 • 2675
Features	<ul style="list-style-type: none"> • incoming flow under seat • no closing impact • straight flow path of the medium • self-adjusting stuffing box for high leak-tightness 	<ul style="list-style-type: none"> • medium is hermetically separated from the actuator and environment • cavity-free and self-draining body design • any flow direction with low-turbulence flow • steam-sterilizable • CIP-compliant • no closing impact • actuator and diaphragm can be removed when the body is installed 	<ul style="list-style-type: none"> • scrapable • minimum dead space • unaffected by contamination • little pressure loss compared to other valve types • seat and seal can be exchanged in the three-piece ball valve when installed <p>Note can be used as process controller only</p>	<ul style="list-style-type: none"> • unaffected by contamination • little pressure loss compared to other valve types • inexpensive • low construction volume
Typical media	<ul style="list-style-type: none"> • water, steam and gases • alcohols, oils, propellants, hydraulic fluids • salt solutions, lyes (organic) • solvents 	<ul style="list-style-type: none"> • neutral gases and liquids • contaminated, abrasive and aggressive media • media of higher viscosity 	<ul style="list-style-type: none"> • neutral gases and liquids • clean water • slightly aggressive media 	<ul style="list-style-type: none"> • neutral gases and liquids • slightly aggressive media

Table 1: Features of the valve types

5.4 Structure of the positioner

The positioner Type 8694 consists of the micro-processor controlled electronics, the position sensor and the pilot valve system. The positioner is operated via 2 buttons and a 4-pole DIP switch. The pilot valve system for single-acting actuators consists of 2 solenoid valves.

5.4.1 Representation

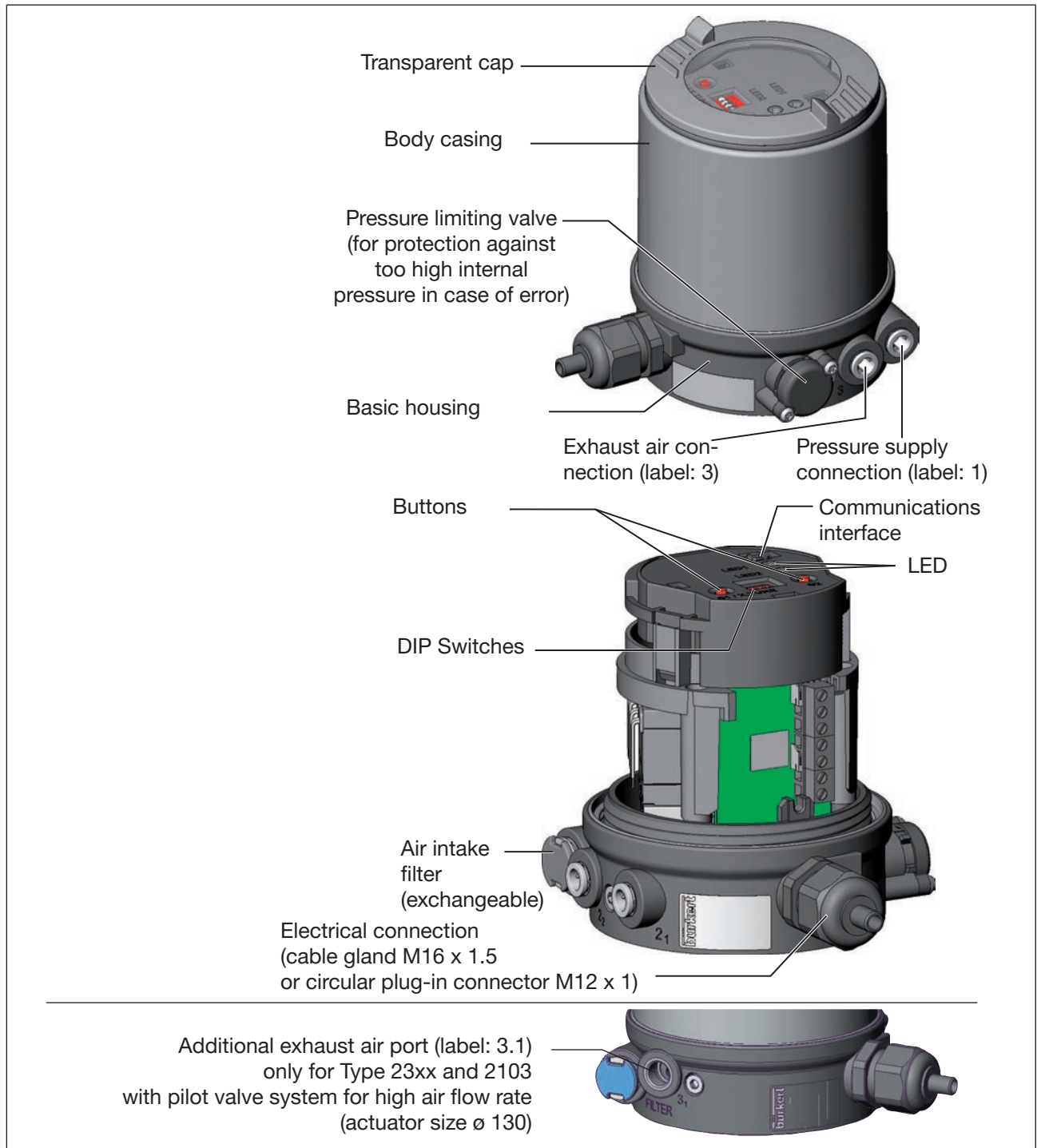

Figure 2: Structure

5.4.2 Features

- **Models**
for single-acting valve actuators.
- **Position sensor**
Contactless and therefore wear-free position sensor.
- **Microprocessor-controlled electronics**
for signal processing, control and valve control.
- **Control module**
The device is controlled via 2 buttons and a 4-pole DIP switch.
2 LEDs (1 RGB LED for device status and 1 green LED for communication interface status) indicate different statuses of the device
- **Pilot valve system**
The control system consists of 2 solenoid valves. One valve is used to aerate and another to deaerate the pneumatic actuator. The solenoid valves operate according to the rocker principle and are controlled with a PWM voltage via the controller. Doing so achieves a higher flexibility with regard to actuator volume and final control speed. The low air flow rate model has an orifice of DN 0.6. In larger pneumatic actuators the solenoid valves feature diaphragm amplifiers to increase the maximum flow and therefore to improve the dynamics (DN 2.5).
- **Position feedback**
The position of the valve can be transmitted to the PLC via an analog 0/4-20 mA output (variant, without fieldbus communication) or digitally via a fieldbus communication (e.g. bÜS, IO-Link).
- **Digital input (for variant without fieldbus communication)**
If a voltage > 10 V is applied, safety position (*SAFEPOS*) is activated*, i.e. the valve is moved to the safety position (factory setting, can be changed with communications software).
- **Pneumatic interfaces**
G1/8" connections
hose plug-in connection Ø6 mm

- **Electrical interfaces**
Circular plug-in connector or cable gland



- **Housing**
The housing of the positioner is protected from excessively high internal pressure, e.g. due to leaks, by a pressure limiting valve.
- **Communications interface**
For exchanging process data and for configuration and parameterization.

5.4.3 Function diagram of the positioner with single-acting actuator

The illustrated function diagram describes the function of the positioner (Type 8694).

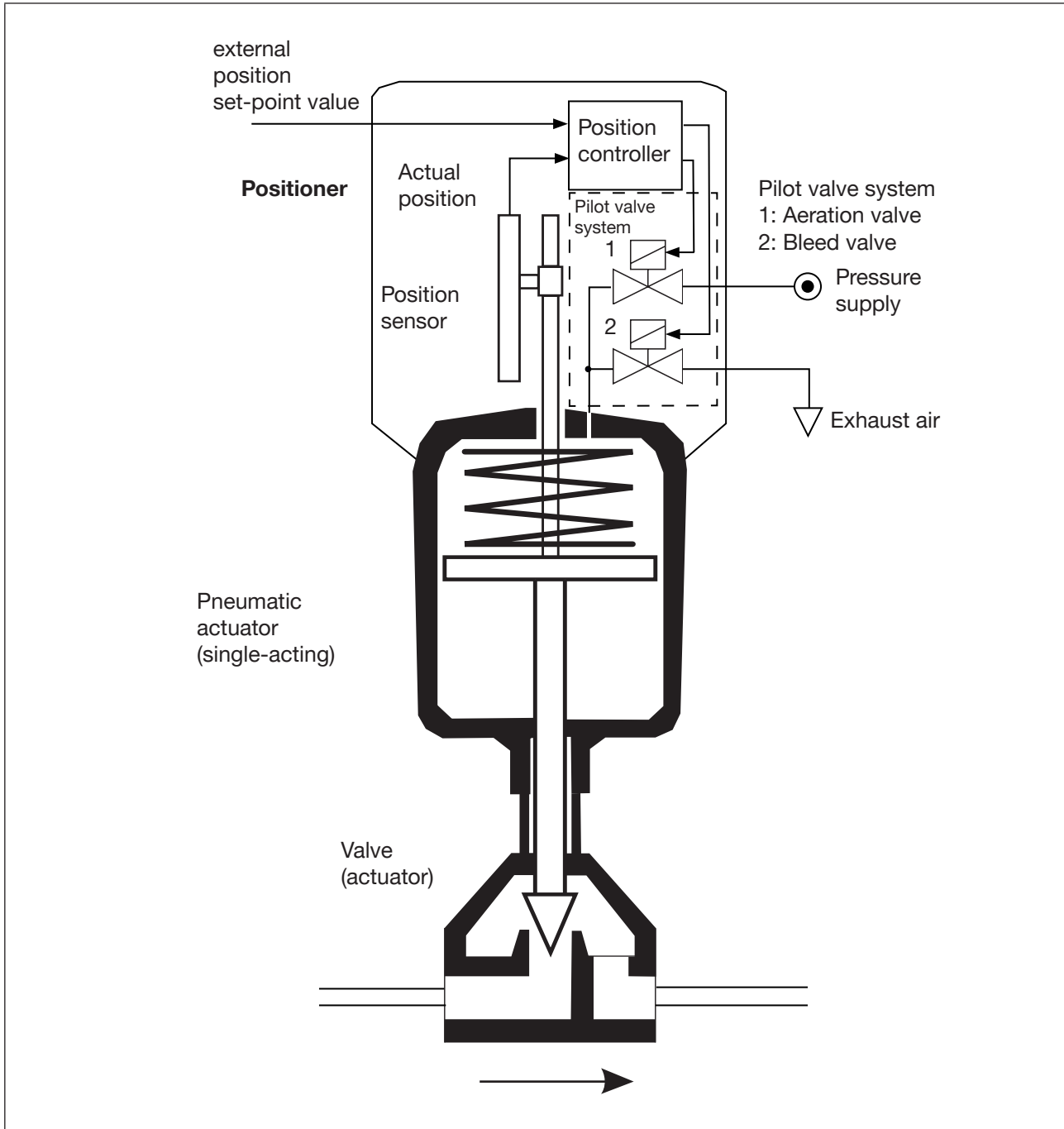

Figure 3: Function diagram

5.5 Type 8694 positioner (position controller)

The position sensor records the current position (POS) of the pneumatic actuator. The position controller compares this actual position value with the set-point value (CMD) which is definable as standard signal. In case of a control deviation (X_{d1}), a pulse-width modulated voltage signal is sent to the pilot valve system as a manipulated variable. If there is a positive control difference in single-acting actuators, the air inlet valve is controlled via output B1. If the control difference is negative, the bleed valve is controlled via output E1. In this way the position of the actuator is changed until control difference is 0. Z1 represents a disturbance variable.

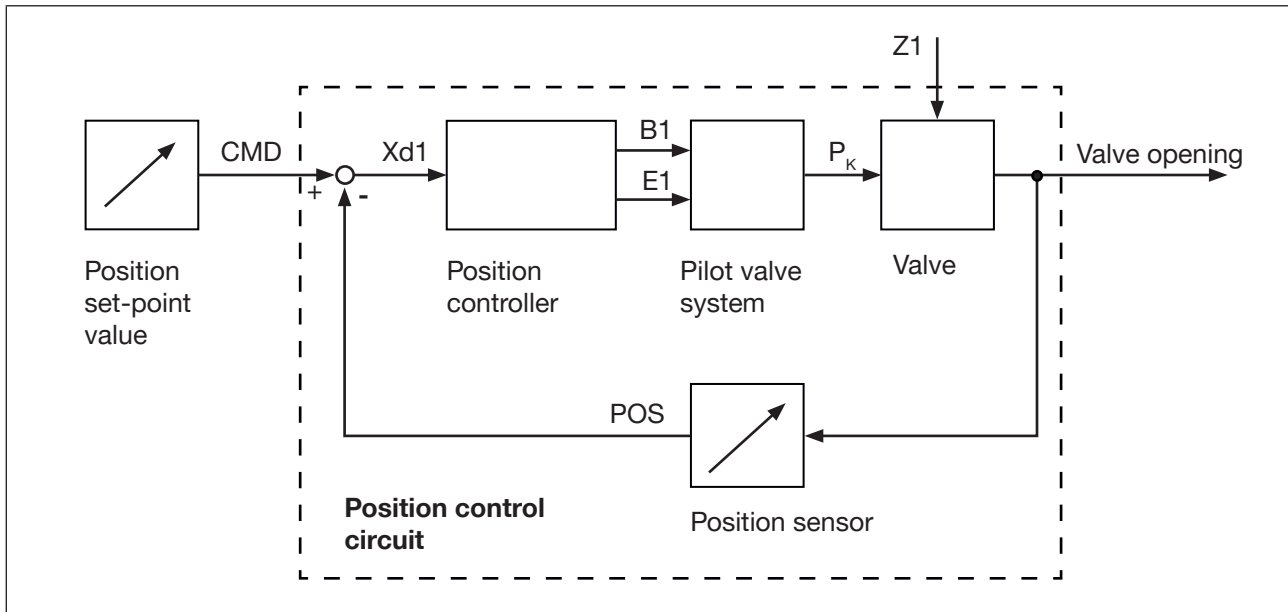

Figure 4: Signal flow plan of position controller

5.5.1 Schematic representation of the position control Type 8694

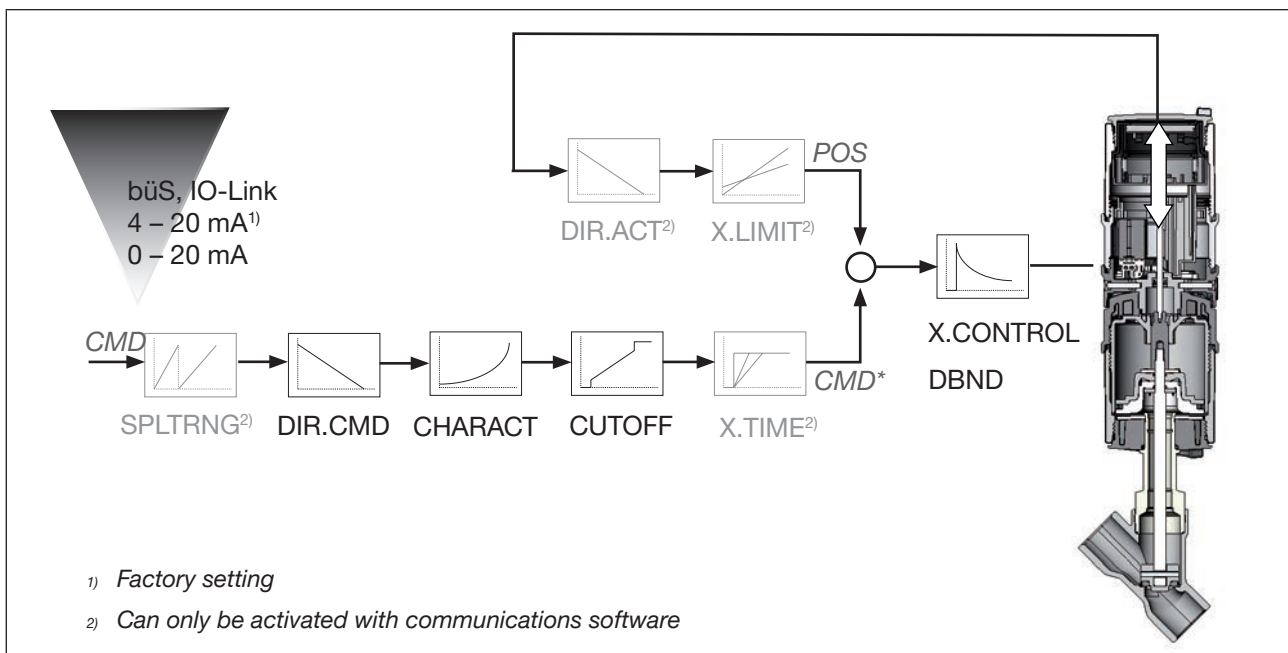

Figure 5: Schematic representation of position control

5.5.2 Functions of the position controller software

Basic functions

- Activation via DIP switches
- Parameter setting via communications software

Function	Effect
Sealing function <i>CUTOFF</i>	Valve closes tight outside the control range. Specification of the value (as %), from which the actuator is completely deaerated (when 0 %) or aerated (when 100 %) (see chapter “7.4 Function of the DIP switches”).
Characteristic correction <i>CHARACT</i>	Linearization of the operating characteristic can be implemented (see chapter “7.4 Function of the DIP switches”).
Reversal of the effective direction set-point value <i>DIR.CMD</i>	Reversal of the effective direction of the set-point value (see chapter “7.4 Function of the DIP switches”).

Table 2: Basic functions

Basic functions

- Activation with buttons or communications software

Function	Effect
Standard signal ³⁾ <i>INPUT</i>	Select set-point value standard signal
Automatic calibration of the position controller <i>X.TUNE</i>	
Reset to factory settings <i>RESET</i>	Reset to factory settings

Table 3: Basic functions

³⁾ Only adjustable with communications software
Only for variant without fieldbus communication.

Auxiliary functions

- Activation and parameter setting with communications software

Function	Effect
Reversal of the effective direction of the actuator <i>DIR.ACT</i>	Assignment of the aeration status of the actuator chamber to the actual position.
Signal split range <i>SPLTRNG</i>	Standard signal as % for which the valve runs through the entire mechanical stroke range.
Stroke limit <i>X.LIMIT</i>	Limit the mechanical stroke range
Limit actuating time <i>X.TIME</i>	Limit the control speed
Control parameters <i>X.CONTROL</i>	Parameterize the position controller
Safety position <i>SAFEPOS</i>	Definition of the safety position
Cable break detection ⁴⁾ <i>SIG.ERROR</i>	Configuration of signal level fault detection
Digital input ⁴⁾ <i>BINARY.IN</i>	Configuration of the digital input
Analog output ⁴⁾ <i>OUTPUT</i>	Configuration of the analog output (variant)

Table 4: Auxiliary functions

⁴⁾ Only for variant without fieldbus communication.

5.6 Interfaces of the positioner

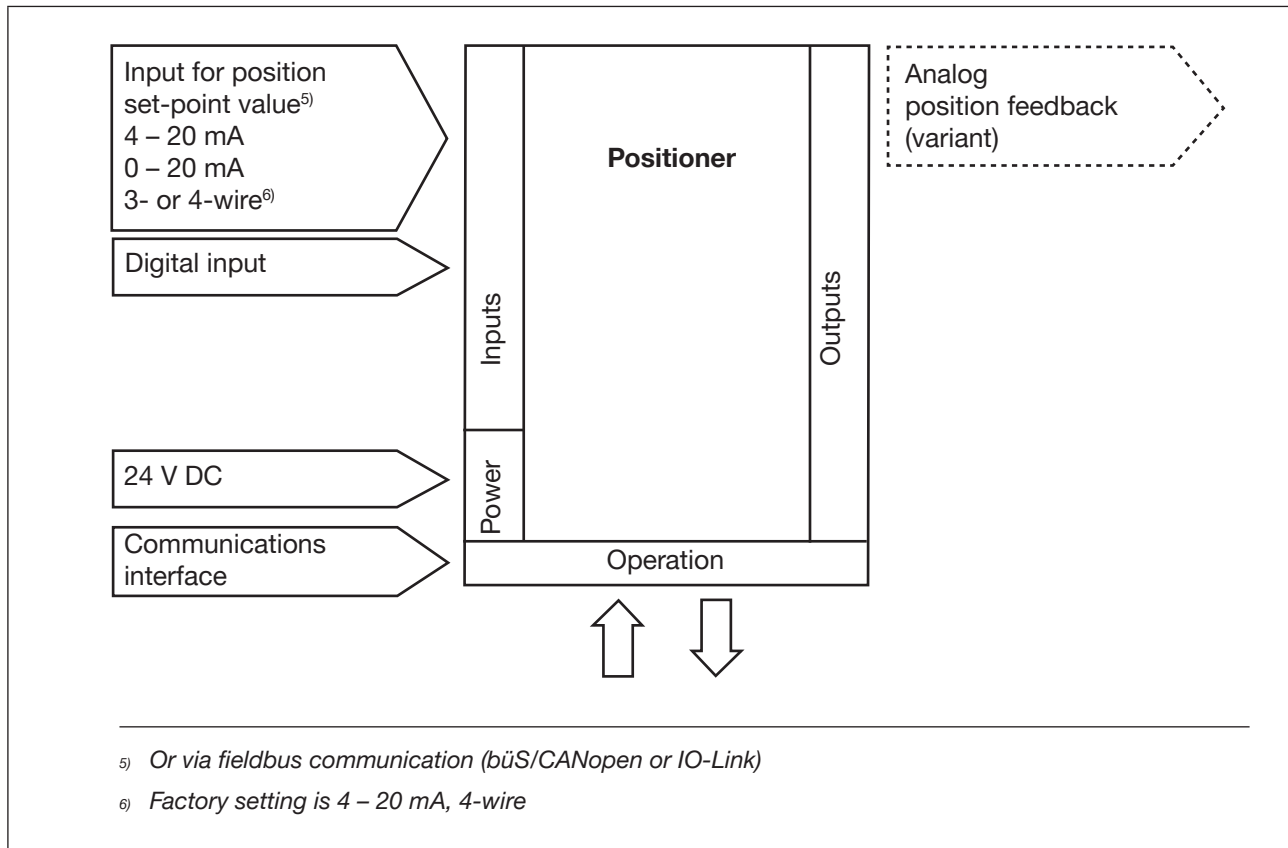

Figure 6: Interfaces



The positioner Type 8694 must be operated in 3-wire or 4-wire connection, i.e. the power (24 V DC) is supplied separately from the set-point value signal.

- Input for position set-point value⁷⁾ (4 – 20 mA corresponds to 0 – 100 % (depending on position of DIP switch 1)).
- Digital input⁷⁾
If a voltage > 10 V is applied, safety position (SAFEPOS) is activated, i.e. the valve is moved to the safety position (factory setting, can be changed with communications software).
- Analog position feedback (variant)⁷⁾
The position of the valve can be transmitted via an analog 4 – 20 mA output to the PLC (4 – 20 mA corresponds to 0 – 100 %).

⁷⁾ Only for variant without fieldbus communication.

6 TECHNICAL DATA

6.1 Conformity

In accordance with the EU Declaration of conformity, the positioner Type 8694 is compliant with the EU Directives.

6.2 Standards

The applied standards on the basis of which compliance with the EU Directives is confirmed are listed in the EU type examination certificate and/or the EU Declaration of Conformity.

6.3 Licenses

The product is approved for use in zone 2 and 22 in accordance with ATEX directive 2014/34/EU category 3GD.



Observe instructions on operation in an explosion-risk (Ex) area.
Observe the ATEX additional instructions.

The product is cULus approved. Instructions for use in the UL area see chapter [“6.8 Electrical data”](#).

6.4 Operating conditions



WARNING

Solar radiation and temperature fluctuations may cause malfunctions or leaks.

- ▶ If the device is used outdoors, do not expose it unprotected to the weather conditions.
- ▶ Ensure that the permitted ambient temperature does not exceed the maximum value or drop below the minimum value.

Ambient temperature see type label

Degree of protection

Evaluated by the manufacturer:	Evaluated by UL:
IP65 / IP67 according to EN 60529 ⁸⁾	UL Type 4x Rating, indoor only ⁸⁾

Operating altitude up to 2000 m above sea level

Relative air humidity max. 90% at 60 °C (non condensing)

⁸⁾ Only if cables, plugs and sockets have been connected correctly and in compliance with the exhaust air concept see chapter [“9 Pneumatic installation”](#).

6.5 Mechanical data

Dimensions See data sheet

Housing material exterior: PPS, PC, VA,
interior: PA 6; ABS

Sealing material EPDM / (NBR)

Stroke range of valve spindle: 2 – 45 mm

6.6 Pneumatic data

Control medium		neutral gases, air Quality classes in accordance with ISO 8573-1
Dust content	Quality class 7	max. particle size 40 µm, max. particle density 10 mg/m ³
Water content	Quality class 3	max. pressure dew point -20 °C or min. 10 °C below the lowest operating temperature
Oil content	Quality class X	max. 25 mg/m ³
Temperature range of the control medium		-10 – +50 °C
Pressure range of the control medium		3 – 7 bar
Air output of pilot valve		7 I _N / min (for aeration and deaeration) (Q _{Nn} - value according to definition for pressure drop from 7 to 6 bar absolute) optional: 130 I _N / min (for aeration and deaeration) (only single-acting)
Connections		Plug-in hose connector Ø6 mm / 1/4" Socket connection G1/8

6.7 Type labels

6.7.1 Type label

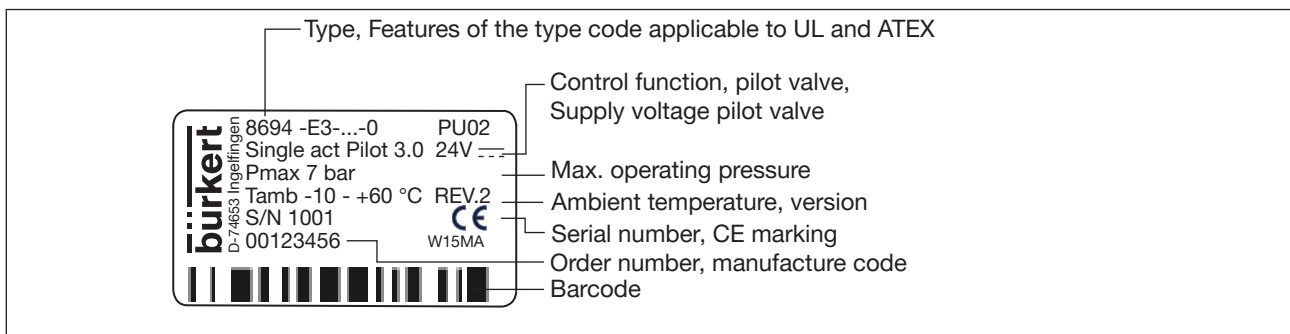

Figure 7: UL type label (example)

6.7.2 UL additional label

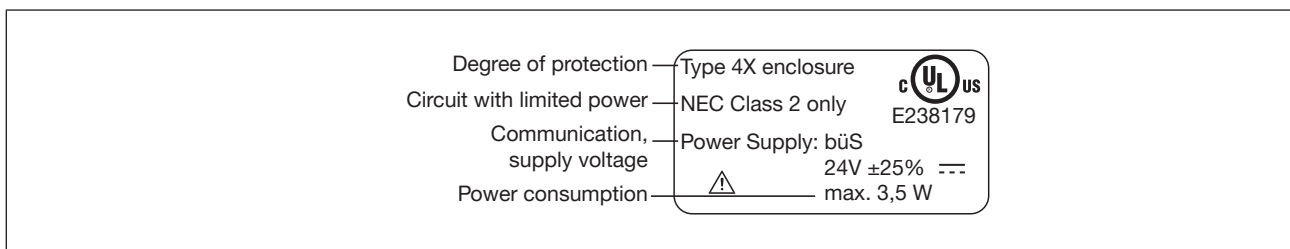

Figure 8: UL additional label (example)

6.8 Electrical data



WARNING

Only circuits with limited power may be used for UL approved components according to “NEC Class 2”.

6.8.1 Electrical data, without fieldbus communication

Protection class	III as per DIN EN 61140 (VDE 0140-1)
Connections	Cable gland M16 x 1.5, wrench size 22 (clamping area 5 – 10 mm) with screw-type terminals for cable cross-sections 0.14 – 1.5 mm ² Circular plug-in connector (M12 x 1, 8-pin)
Operating voltage	24 V DC ± 25%, max. residual ripple 10 %
Current consumption	max. 190 mA
Power consumption	max. 3.5 W
Input resistance for set-point value signal	75 Ω at 0/4 – 20 mA / 12 bit resolution
Analogue position feedback max. load for current output 0/4 – 20 mA	560 Ω
Digital input	0 – 5 V = logical “0”, 12 - 30 V = logical “1” logic invertible in software
Communications interface	Connection to PC via USB bus interface set
Communication software	Bürkert Communicator

6.8.2 Electrical data, IO-Link

Protection class	III as per DIN EN 61140 (VDE 0140-1)
Connection	Circular plug-in connector M12 x 1, 5-pin, A-coded
Port Class A	
Operating voltage	24 V DC $\pm 25\%$ (according to specification)
Current consumption	max. 150 mA
Port Class B	
Operating voltage	
System supply (Pin 1+3)	24 V DC $\pm 25\%$ (according to specification)
Actuator supply (Pin 2+5) ⁹⁾	24 V DC $\pm 25\%$ (according to specification)
Current consumption	
System supply (Pin 1+3)	max. 50 mA
Actuator supply (Pin 2+5)	max. 100 mA
Total power consumption	max. 3,5 W

⁹⁾ Actuator supply is galvanically isolated from system supply in accordance with IEC 60664 and for electrical safety in accordance with SELV from IEC 61010-2-201

6.8.3 Electrical data, bÜS

Protection class	III as per DIN EN 61140 (VDE 0140-1)
Connection	Circular plug-in connector M12 x 1, 5-pin, A-coded
Operating voltage	24 V DC $\pm 25\%$
Current consumption	max. 150 mA
Total power consumption	max. 3,5 W

6.8.4 Electrical data, AS-Interface

Protection class	III as per DIN EN 61140 (VDE 0140-1)
Connection	
Supply	Circular plug-in connector M12 x 1, 4-pin
Communication	bÜS service interface
Operating voltage	
System supply (Pin 1+3)	via AS-Interface power supply unit acc. to 29.5 V...31.6 V \equiv
only for variant with additional actuator supply (AUX Power) (Pin 2+4)*	24 V $\equiv \pm 10\%$
Current consumption	
System supply (Pin 1+3)	without additional actuator supply max. 150 mA @23 V \equiv with additional actuator supply (AUX Power) max. 50 mA @23 V \equiv
only with additional actuator supply (AUX Power) (Pin 2+4)	max. 100 mA @24 V $\pm 10\%$
Communication software	Bürkert Communicator

* The power supply unit must include a secure disconnection in accordance with IEC 364-4-41 (PELV or SELV)

6.9 Factory settings of the positioner

Functions can be activated via DIP switches:

Function	Parameter	Value
<i>CUTOFF</i>	Sealing function below Sealing function above	2 % 98 %
<i>CHARACT</i>	Characteristic correction	FREE ¹⁰⁾
<i>DIR.CMD</i>	Reversal of the effective direction set-point value	Off

Table 5: Factory settings

Functions can be activated via communications software:

Function	Parameter	Value
<i>INPUT</i>	Set-point value input	4 – 20 mA, 4-wire
<i>DIR.ACT</i>	Reversal of the effective direction of the actuator	Off
<i>SPLTRNG</i> Function deactivated	Signal split range below Signal split range above	0 % 100 %
<i>X.LIMIT</i> Function deactivated	Stroke limit below Stroke limit above	0 % 100 %
<i>X.TIME</i> Function deactivated	Actuating time Open Actuating time Closed	(1 s) values determined by <i>X.TUNE</i> (1 s) values determined by <i>X.TUNE</i> After implementation of <i>RESET</i> : 5 s
<i>X.CONTROL</i>	Deadband Open amplification factor Close amplification factor	1,0 % (1) values determined by <i>X.TUNE</i> (1) values determined by <i>X.TUNE</i> After implementation of <i>RESET</i> : 1
<i>SAFEPOS</i>	Safety position	0 %
<i>SIG.ERROR</i> ¹¹⁾ Function deactivated	Cable break detection set-point value	Deactivated
<i>BINARY.IN</i> ¹¹⁾	Digital input function Operating principle of digital input	Safety position Normally open
<i>OUTPUT</i> (variant)	Norm signal output: Parameter Norm signal output: Type	Position (POS) 4 – 20 mA

Table 6: Factory settings

¹⁰⁾ Without change to the settings via the communications software a linear characteristic is stored in *FREE*.

¹¹⁾ Only for variant without fieldbus communication.

7 CONTROL AND DISPLAY ELEMENTS

The following chapter describes the operating statuses as well as the control and display elements of the positioner. Further information on the operation of the positioner can be found in the chapter entitled [“14 Start-up”](#).

7.1 Operating state

! To operate the DIP switches and buttons, make sure that the local control lock is deactivated/unlocked (factory setting): with communication software or fieldbus communication.

AUTOMATIC (AUTO)

Normal controller mode is implemented and monitored in AUTOMATIC operating state.

MANUAL

In MANUAL operating state the valve can be opened and closed manually via the buttons.

DIP switch 4 can be used to switch between the two operating states AUTOMATIC and MANUAL.

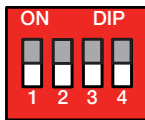

7.2 Control and display elements of the positioner

! To operate the DIP switches and buttons, make sure that the local control lock is deactivated/unlocked (factory setting): with communication software or fieldbus communication.

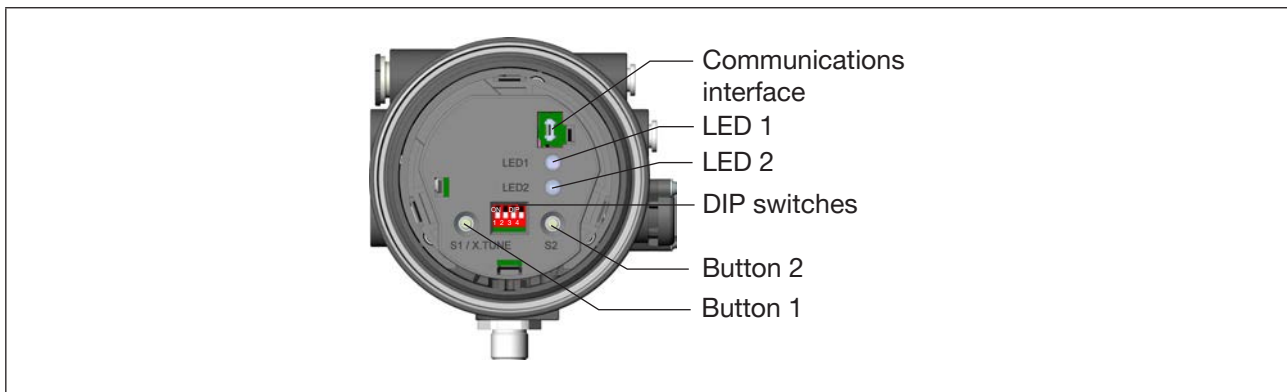

Figure 9: Description of control elements

The positioner features 2 buttons, 4-pole DIP switches and 2 LEDs as a display element.

NOTE

Breakage of the pneumatic connection pieces due to rotational impact.

- ▶ When unscrewing and screwing in the body casing or transparent cap, do not hold the actuator of the process valve but the basic housing.

→ To operate the buttons and DIP switches, unscrew the transparent cap.

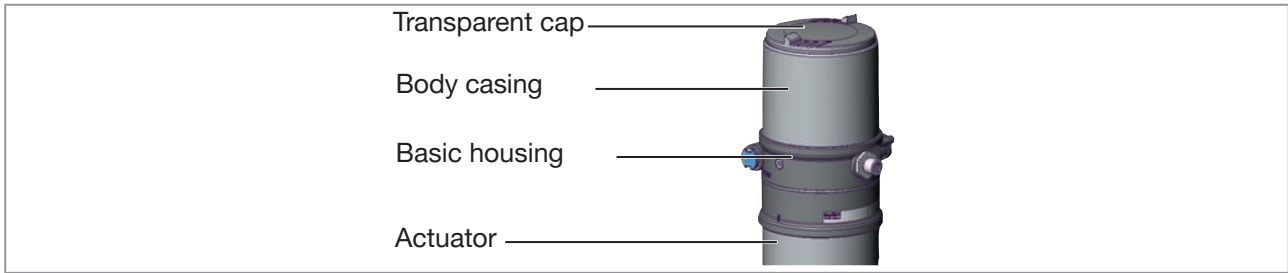

Figure 10: Open positioner

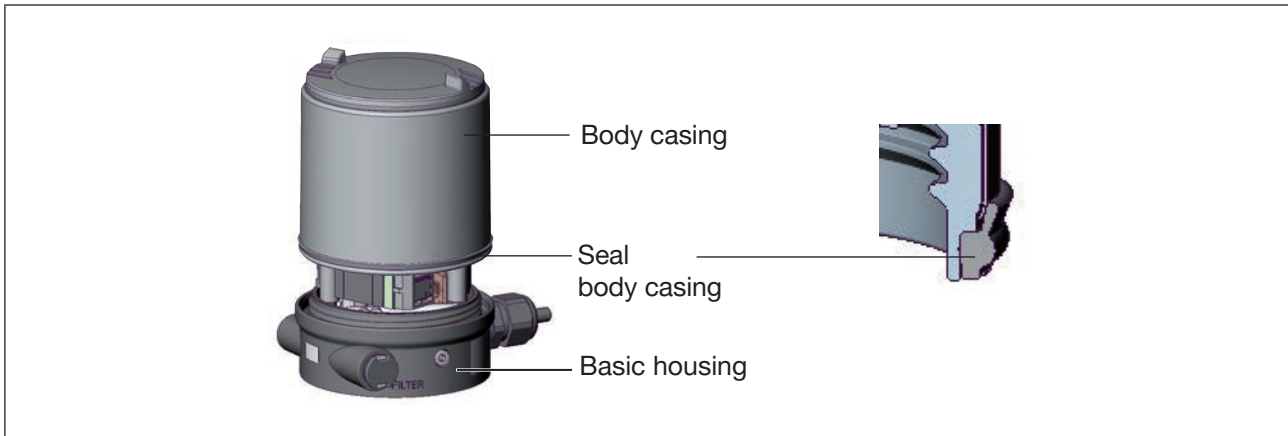

Figure 11: Position of the seal in the body casing

NOTE

Damage or malfunction due to penetration of dirt and humidity.
▶ To observe degree of protection IP65 / IP67, screw the transparent cap in all the way.

→ Close the device (assembly tool: 674077¹²⁾).

MAN 1000396587 EN Version: F Status: RL (released | freigegeben) printed: 07.04.2026

¹²⁾ The assembly tool (674077) is available from your Bürkert sales office.

7.3 Configuration of the buttons

! To operate the DIP switches and buttons, make sure that the local control lock is deactivated/unlocked (factory setting): with communication software or fieldbus communication.

The configuration of the 2 buttons varies depending on the operating state (AUTOMATIC / MANUAL).

The description of the operating states (AUTOMATIC / MANUAL) can be found in the chapter entitled [“7.1 Operating state”](#).

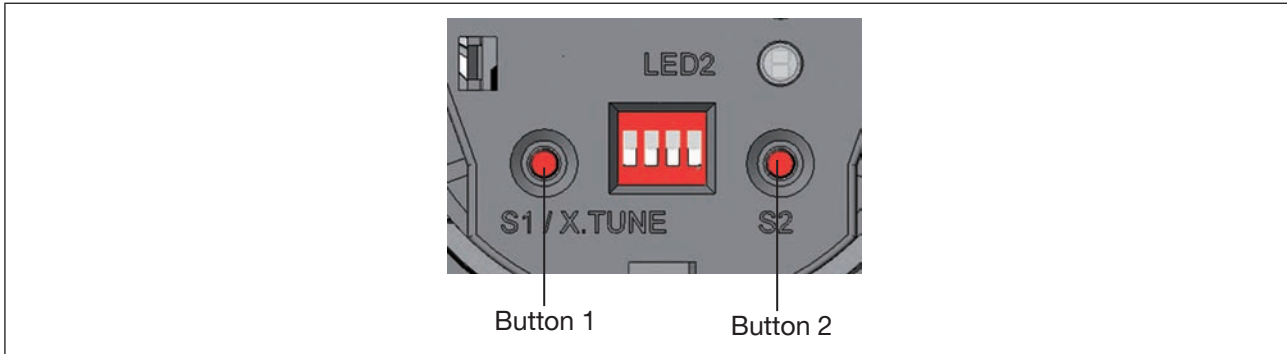

Figure 12: Description of the buttons

NOTE

Breakage of the pneumatic connection pieces due to rotational impact.

- ▶ When unscrewing and screwing in the body casing or transparent cap, do not hold the actuator of the process valve but the basic housing.

→ To operate the buttons, unscrew the transparent cap

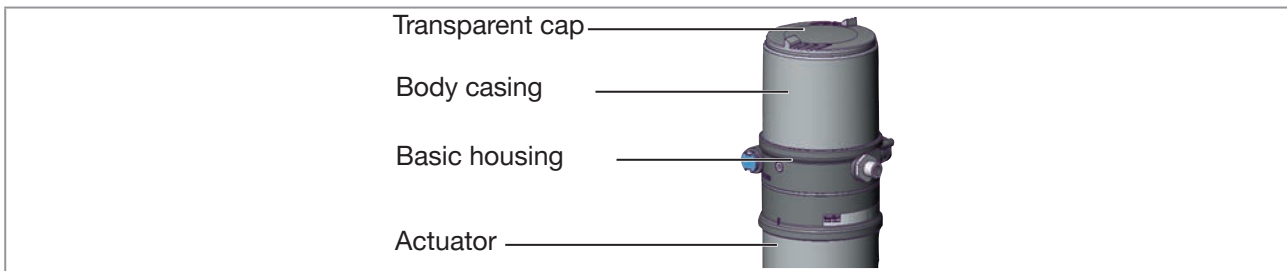

Figure 13: Open positioner

MANUAL operating state (DIP switch 4 set to ON):

Button	Function
1	Aerate (manually open / close the actuator) ¹³⁾
2	Deaerate (manually open / close the actuator) ¹³⁾
1 and 2 simultaneously	Longer than 10 s (< 30 s, LED 2 flashes at 5 Hz): Device restart
	Longer than 30 s (LED 2 flashes at 10 Hz): Reset device to factory setting

Table 7: Configuration of the buttons for MANUAL operating state

¹³⁾ Depending on the operating principle of the actuator.

AUTOMATIC operating state (DIP switch 4 set to OFF):

Button	Function
1	Start the X.TUNE function: press button for 5 seconds until LED 2 (green) flashes
2	-
1 and 2 simultaneously	Longer than 10 s (< 30 s, LED 2 flashes at 5 Hz): Device restart
	Longer than 30 s (LED 2 flashes at 10 Hz): Reset device to factory setting

Table 8: Configuration of the buttons for AUTOMATIC operating state

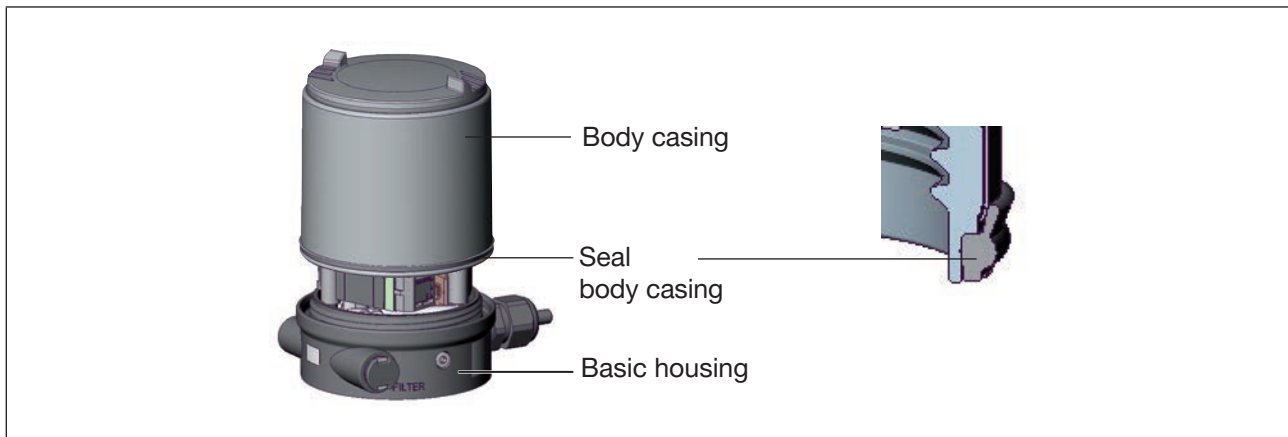

Figure 14: Position of the seal in the body casing

NOTE

Breakage of the pneumatic connection pieces due to rotational impact.

- ▶ When unscrewing and screwing in the body casing or transparent cap, do not hold the actuator of the process valve but the basic housing.

Damage or malfunction due to penetration of dirt and humidity.

- ▶ To observe degree of protection IP65 / IP67, screw the transparent cap in all the way.

→ Close the device (assembly tool: 674077¹⁴⁾).

¹⁴⁾ The assembly tool (674077) is available from your Bürkert sales office.

7.4 Function of the DIP switches



To operate the DIP switches and buttons, make sure that the local control lock is deactivated/unlocked (factory setting): with communication software or fieldbus communication.

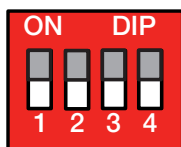

NOTE

Breakage of the pneumatic connection pieces due to rotational impact.

- ▶ When unscrewing and screwing in the body casing or transparent cap, do not hold the actuator of the process valve but the basic housing.

→ To operate the DIP switches, unscrew the transparent cap

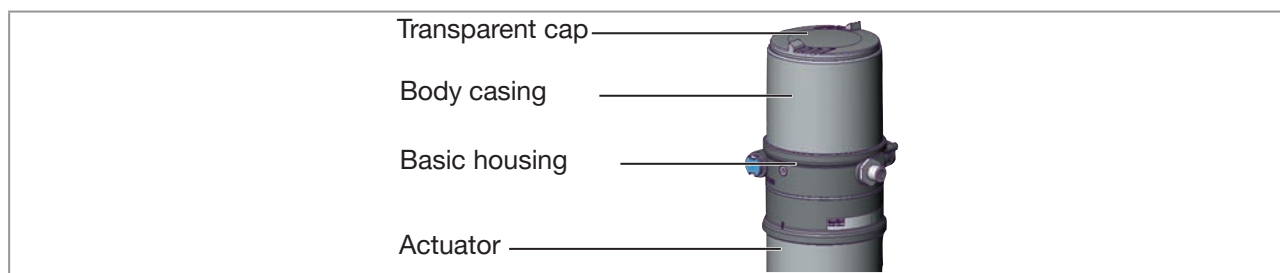

Figure 15: Open positioner

DIP Switches	Position	Function
1	ON	Reversal of the effective direction of the set-point value (<i>DIR.CMD</i>) (set-point value 20 – 4 mA corresponds to position 0 – 100 %), descending
	OFF	Normal effective direction of the set-point value (set-point value 4 – 20 mA corresponds to position 0 – 100 %), ascending
2	ON	Sealing function active. The valve completely closes below 2 % ¹⁵⁾ and opens above 98 % of the set-point value (<i>CUTOFF</i>)
	OFF	No sealing function
3	ON	Characteristic correction for adjustment of the operating characteristic (linearization of the process characteristic <i>CHARACT</i>) ¹⁶⁾
	OFF	Linear characteristic
4	ON	Operating status MANUAL (BY HAND)
	OFF	Operating status AUTOMATIC (AUTO)

Table 9: DIP Switches

¹⁵⁾ Factory setting, can be changed via communications software.

¹⁶⁾ The characteristic type can be changed via communications software.



Information about the communications software:

The switching position of the DIP switch has priority over the settings via the communications software.

If the values of the sealing function (*CUTOFF*) or the correction characteristic (*CHARACT*) are changed via the communications software, the corresponding function must be active (DIP switches set to ON). The effective direction of the set-point value (*DIR.CMD*) can be changed via the DIP switches only. If the correction characteristic (*CHARACT*) is not changed via the communications software, a linear characteristic is saved when DIP switch 3 is set to ON.



A detailed description of the functions can be found in the chapter entitled [“Basic functions”](#).

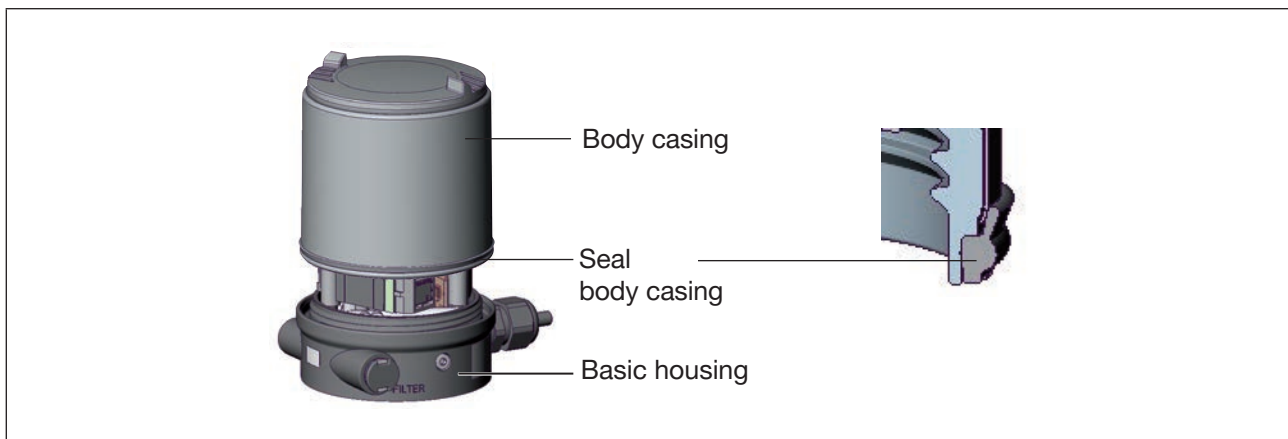

Figure 16: Position of the seal in the body casing

NOTE

Breakage of the pneumatic connection pieces due to rotational impact.

- ▶ When unscrewing and screwing in the body casing or transparent cap, do not hold the actuator of the process valve but the basic housing.

Damage or malfunction due to penetration of dirt and humidity.

- ▶ To observe degree of protection IP65 / IP67, screw the transparent cap in all the way.

→ Close the device (assembly tool: 674077¹⁷⁾).

¹⁷⁾ The assembly tool (674077) is available from your Bürkert sales office.

7.5 Display of the LEDs

LED 1 (RGB)	Display of the device status and valve position	
LED 2 (green)	Display of the bus status Feedback during pressing buttons to start functions <ul style="list-style-type: none">• X.TUNE• Device restart• Reset to factory settings	

Figure 17: LED display

7.5.1 Device status display

The LED 1 (RGB) show the device status.

The user can set the following LED modes for the display of device status and valve position.

- NAMUR mode
- Valve mode
- Valve mode with warnings (factory setting)
- Fixed color
- LED off

The LED mode and the colors of the valve position can be set with the Bürkert Communicator.

IO-Link:

The LED mode and the colors of the valve position can be also set with an acyclic parameter (see parameter list).



The description for setting the LED mode can be found in the chapter [“18.2.10 Setting the LED mode, device status”](#) .

7.5.1.1 Valve mode

Displays in valve mode:

- Valve position: open, half-way, closed
- Device status: Error

Valve position	Valve position status, color	Device status: Error status, color	
Open	is lit yellow ¹⁸⁾	flashes red	alternately with yellow ¹⁸⁾
Half-way	is lit white ¹⁸⁾¹⁹⁾	flashes red	alternately with white ¹⁸⁾¹⁹⁾
Closed	is lit green ¹⁸⁾	flashes red	alternately with green ¹⁸⁾

Table 10: Valve mode

7.5.1.2 Valve mode + warnings

Displays in valve mode + warnings:

- Valve position: open, half-way, closed
- Device status: failure, function check, out of specification, maintenance required (according to NAMUR)

Valve position	Device status	
	Status, color	Normal operation
Open	is lit yellow ¹⁸⁾	--
Half-way	is lit white ¹⁸⁾¹⁹⁾	--
Closed	is lit green ¹⁸⁾	--

Table 11: Valve mode + warnings, normal operation

If several device statuses exist simultaneously, the device status with the highest priority is displayed.

Valve position	Device status				
	Failure	Function check	Out of specification	Maintenance required	
	Status, color	Status, color	Status, color	Status, color	
Open	flashes red	flashes orange	flashes yellow	flashes blue	alternately with yellow ¹⁸⁾
Half-way	flashes red	flashes orange	flashes yellow	flashes blue	alternately with white ¹⁸⁾¹⁹⁾
Closed	flashes red	flashes orange	flashes yellow	flashes blue	alternately with green ¹⁸⁾

Table 12: Valve mode + warnings, device status

For warning messages, the LEDs are briefly switched off between the change of the colors.

For localizations, the colors are only shown momentarily.

¹⁸⁾ Factory setting, selectable colors for the valve position: Off, white, green, blue, yellow, orange, red

¹⁹⁾ As of firmware A.1.6

7.5.1.3 NAMUR mode

The device status LED show the device status.

The display elements change color in accordance with NAMUR NE 107.

If several device statuses exist simultaneously, the device status with the highest priority is displayed. The priority is determined by the severity of the deviation from controlled operation (red LED = failure = highest priority).

Status display in accordance with NE 107, edition 2006-06-12			
Color	Color code	Status	Description
Red	5	Outage, error or malfunction	Normal operation is not possible due to a malfunction in the device or on its peripheral equipment.
Orange	4	Function check	Work is being carried out on the device; normal operation is therefore temporarily not possible
Yellow	3	Out of specification	Ambient conditions or process conditions for the device are outside the specified area.
Blue	2	Maintenance required	The device is in normal operation, although a function is briefly restricted. → Service device.
Green	1	Diagnostics active	Device is operating perfectly. Status changes are indicated in different colors. Messages are transmitted via a fieldbus if connected.

Table 13: Description of the colors

7.5.2 Status LED, green

LED 2 (green) indicates the following:

Color	Status	Description
Green	is not lit	IO-Link communication inactive ²⁰⁾
	flashes	IO-Link communication active ²⁰⁾
	flashes with 5 Hz	Feedback during pressing button 1 (start X.TUNE) or button 1+2 (device restart) > 5 s
	flashes with 10 Hz	Feedback during pressing button 1+2 (reset to factory settings) > 30 s

Table 14: LED 2, green

²⁰⁾ Only IO-Link variant.

7.6 Error messages

7.6.1 Messages for device status „Out of specification“

Message	Description	Procedure
Temperature limit exceeded	Ambient temperature is too high	Reduce ambient temperature. If problems continue, contact your Bürkert Service Center
Temperature limit not achieved	Ambient temperature is too low	Increase ambient temperature
Voltage limit exceeded	Supply voltage is too high	Check supply voltage
Voltage limit not achieved	Supply voltage is too low	Check supply voltage
CMD sensor break	Cable break of the set-point value signal.. The message can be parameterized (see “18.2.7”)	Check the signal line of the set-point value

Table 15: Messages

7.6.2 Messages: Actuator moves to safety position

Message	Description	Procedure
Excess temperature detected	Device temperature is too high for operation	Reduce ambient temperature. If problems continue, contact your Bürkert Service Center
Insufficient temperature detected	Device temperature is too low for operation	Increase ambient temperature
Excess voltage detected	Supply voltage is too high for operation	Check supply voltage
Insufficient voltage detected	Failure of the supply voltage or supply voltage is too low for operation	Check supply voltage. If problems continue, contact your Bürkert Service Center
Persistent memory cannot be used: Defective or not available	Writing or reading error of the internal data storage EEPROM	Restart device. If problems continue, contact your Bürkert Service Center
BueS event: Producer(s) not found	Assigned external bÜS producer cannot be found	Check signal to bÜS partner
BueS event: Bus connection lost / not available	bÜS network cannot be found	Check bÜS network
BueS event: Producer is not operational	Producer is not operational in the status	Check bÜS producer
BueS event: A device is using the same address	Another bÜS participant is using the same address	Assign device and bÜS participant a unique address

IO-Link error	No valid process data is received	- Check connection to the IO-Link master - Check whether valid setpoints are sent to the device via the IO-Link interface
X.TUNE error occurred	The last X.TUNE was not successful.	-Check compressed air supply -Run X.TUNE again
Actuator supply is down	The actuator supply voltage is too low. Only with IO-Link	Check actuator supply voltage
POS.Monitor	The set-point position is not reached	-Run X.TUNE -Check compressed air supply.
CMD sensor break	Cable break of the set-point value signal.. The message can be parameterized (see "18.2.7")	Check the signal line of the set-point value

Table 16: Messages

8 INSTALLATION

8.1 Safety instructions



DANGER

Risk of injury from high pressure in the equipment/device.

- ▶ Before working on equipment or device, switch off the pressure and deaerate/drain lines.

Risk of electric shock.

- ▶ Before working on equipment or device, switch off the power supply and secure to prevent reactivation.
- ▶ Observe applicable accident prevention and safety regulations for electrical equipment.



WARNING

Risk of injury from improper installation.

- ▶ Installation may be carried out by authorized technicians only and with the appropriate tools.

Risk of injury from unintentional activation of the system and an uncontrolled restart.

- ▶ Secure system from unintentional activation.
- ▶ Following assembly, ensure a controlled restart.

8.2 Installation of the positioner Type 8694 on process valves of series 2103, 2300 and 2301

NOTE

When mounting on process valves with a welded connection, follow the installation instructions in the operating instructions for the process valve.

Procedure:

1. Install switch spindle

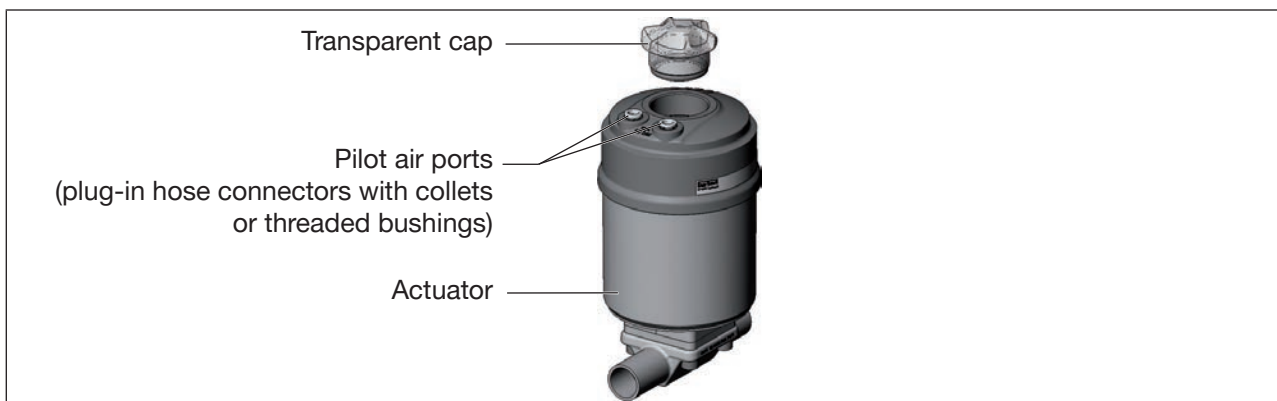

Figure 18: Installation of the switch spindle (1), series 2103, 2300 and 2301

→ Unscrew the transparent cap on the actuator and unscrew the position display (yellow cap) on the spindle extension (if present).

→ For version with plug-in hose connector, remove the collets (white nozzles) from both pilot air ports (if present).

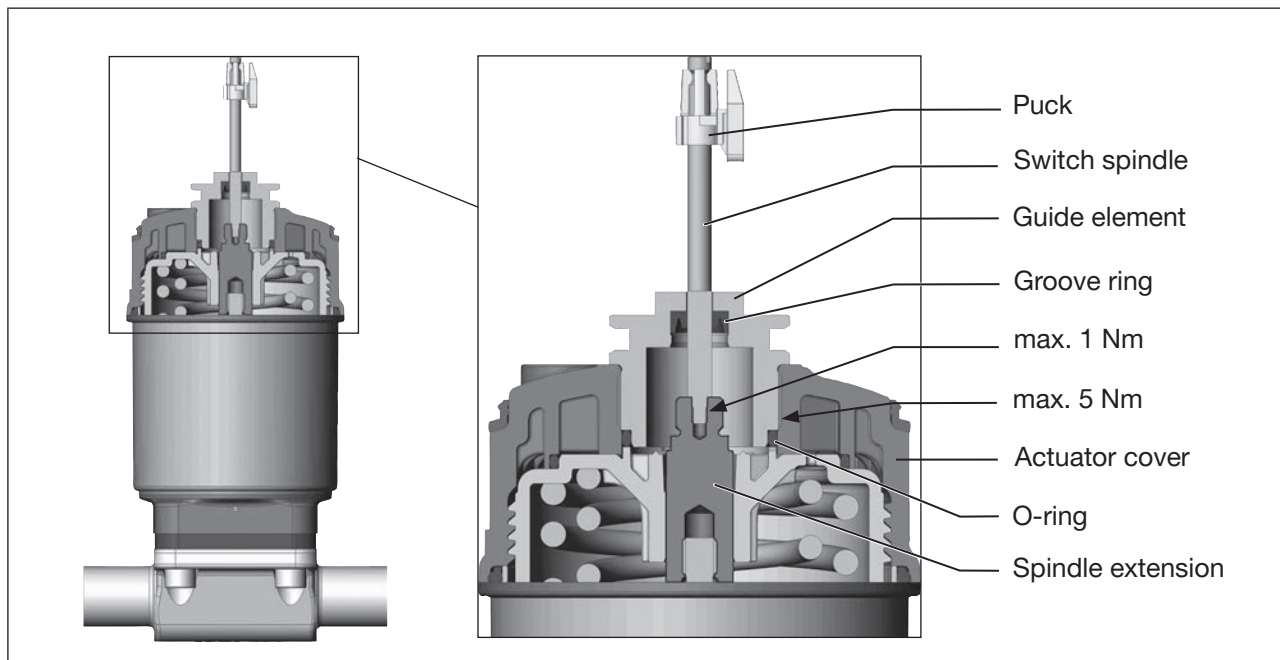

Figure 19: Installation of the switch spindle (2), series 2103, 2300 and 2301

NOTE

Improper installation may damage the groove ring in the guide element.

The groove ring is already pre-assembled in the guide element and must be “locked into position” in the undercut.

- ▶ When installing the switch spindle, do not damage the groove ring.

→ Push the switch spindle through the guide element.

NOTE

Screw locking paint may contaminate the groove ring.

- ▶ Do not apply any screw locking paint to the switch spindle.

→ To secure the switch spindle, apply some screw locking paint (Loctite 290) in the tapped bore of the spindle extension in the actuator.

→ Check that the O-ring is correctly positioned.

→ Screw the guide element to the actuator cover (maximum torque: 5 Nm).

→ Screw switch spindle onto the spindle extension. To do this, there is a slot on the upper side (maximum torque: 1 Nm).

→ Push puck onto the switch spindle and lock into position.

2. Install sealing rings

→ Pull the form seal onto the actuator cover (smaller diameter points upwards).

→ Check that the O-rings are correctly positioned in the pilot air ports.

! When the positioner is being installed, the collets of the pilot air ports must not be fitted to the actuator.

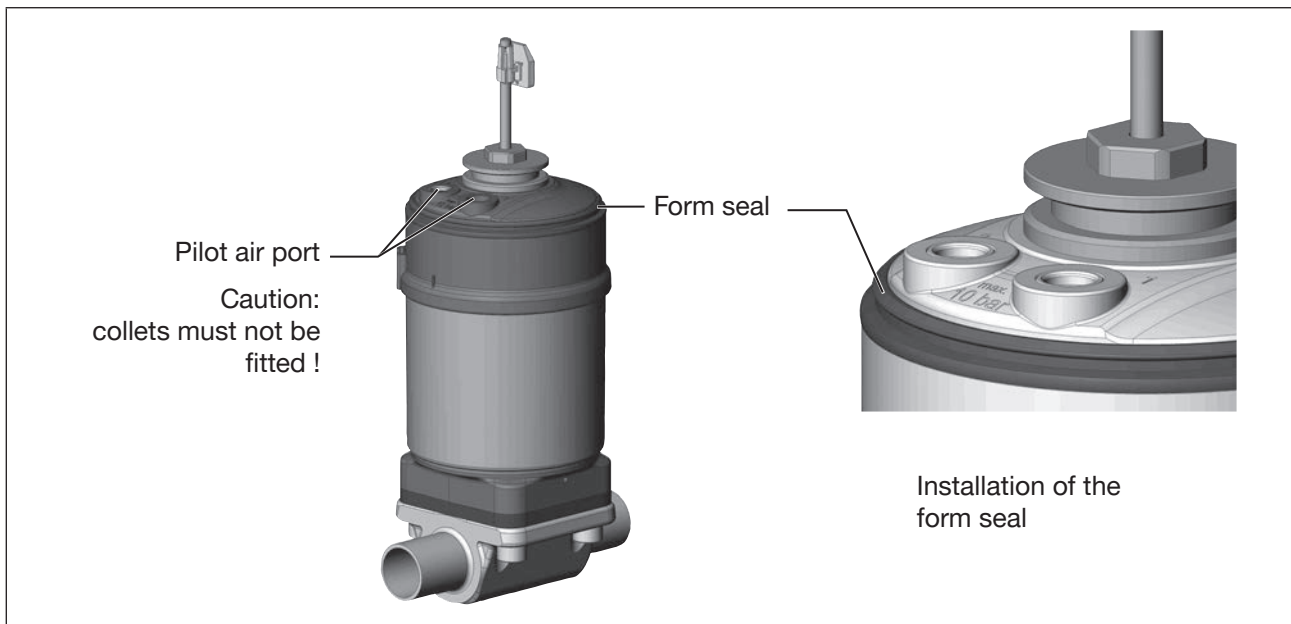

Figure 20: Installation of the sealing rings, series 2103, 2300 and 2301

3. Install positioner

→ Align the puck and the positioner until

1. the puck can be inserted into the guide rail of the positioner (see “Figure 21”) and
2. the connection pieces of the positioner can be inserted into the pilot air ports of the actuator (see also “Figure 22”).

NOTE

Damaged printed circuit board or malfunction.
 ▶ Ensure that the puck is situated flat on the guide rail.

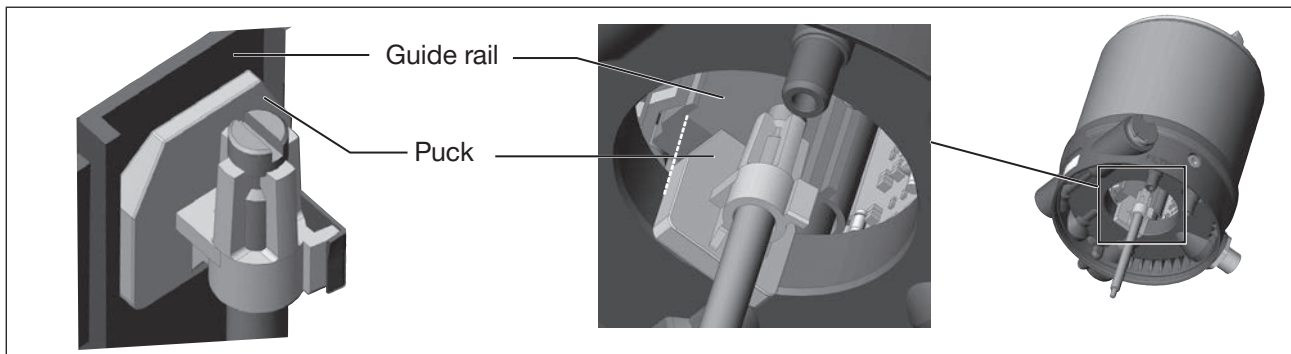

Figure 21: Aligning the puck

MAN 1000396587 EN Version: F Status: RL (released | freigegeben) printed: 07.04.2026

→ Push the positioner, without turning it, onto the actuator until no gap is visible on the form seal.

NOTE

Too high torque when screwing in the fastening screw does not ensure degree of protection IP65 / IP67.
▶ The fastening screws may be tightened to a maximum torque of 1.5 Nm only.

→ Attach the positioner to the actuator using the two side fastening screws. In doing so, tighten the screws only hand-tight (max. torque: 1.5 Nm).

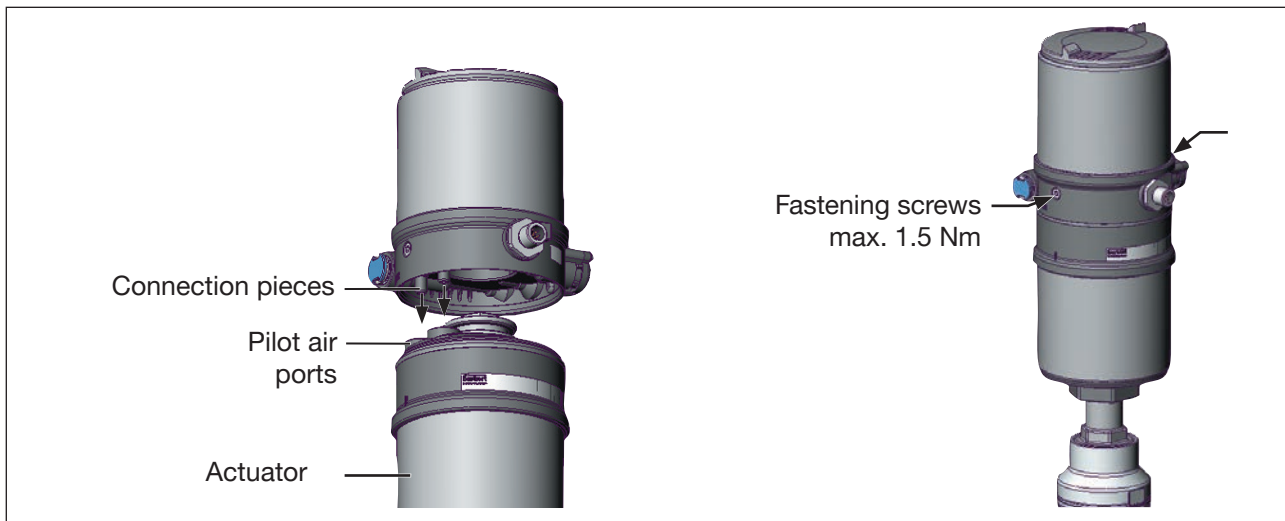

Figure 22: Installation of positioner, series 2103, 2300 and 2301

8.3 Installing the positioner Type 8694 on process valves belonging to series 26xx and 27xx

Procedure:

1. Install switch spindle

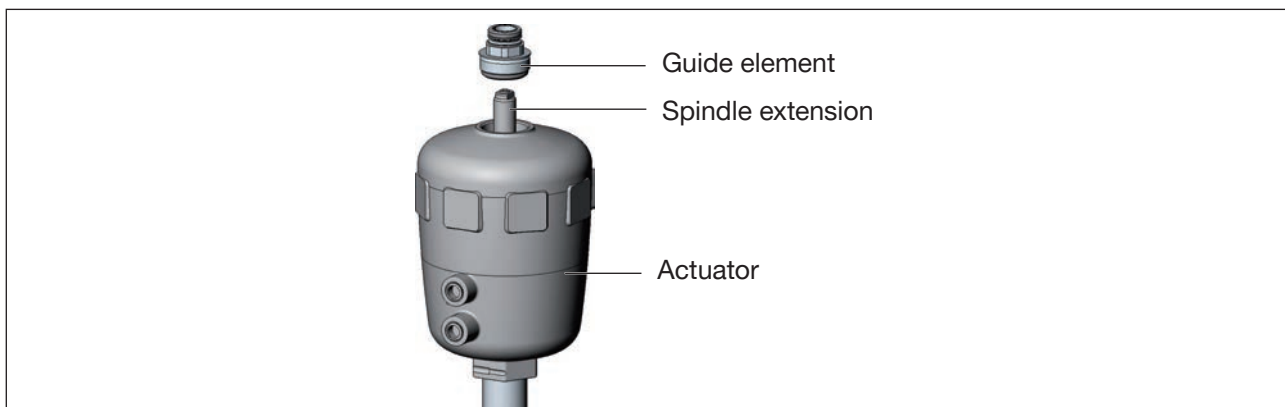

Figure 23: Installing the switch spindle (1), series 26xx and 27xx

→ Unscrew the already fitted guide element from the actuator (if present).

→ Remove intermediate ring (if present).

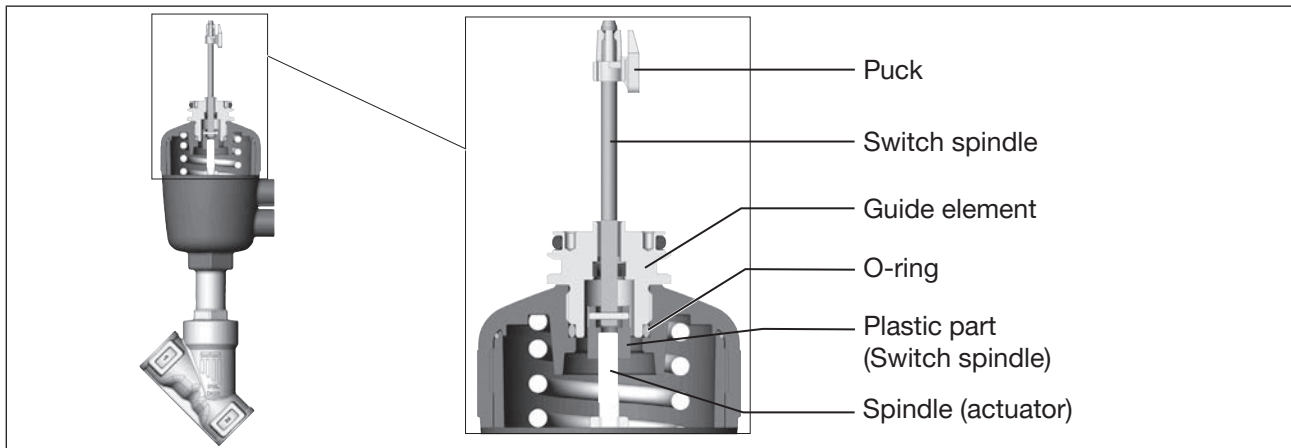

Figure 24: Installing the switch spindle (2), series 26xx and 27xx

- Press the O-ring downwards into the cover of the actuator.
- Actuator size $\varnothing 125$ and bigger with high air flow rate:
remove existing spindle extension and replace with the new one. To do this, apply some screw locking paint (Loctite 290) in the tapped bore of the spindle extension.
- Screw the guide element into the cover of the actuator using a face wrench²¹⁾ (torque: 8.0 Nm).
- To secure the switch spindle, apply some screw locking paint (Loctite 290) to the thread of the switch spindle.
- Screw the switch spindle onto the spindle extension. To do this, there is a slot on the upper side (maximum torque: 1 Nm).
- Push the puck onto the switch spindle until it engages.

²¹⁾ Journal \varnothing : 3 mm; journal gap: 23.5 mm

2. Install positioner

→ Push the positioner onto the actuator. The puck must be aligned in such a way that it is inserted into the guide rail of the positioner.

NOTE

Damaged printed circuit board or malfunction.

- ▶ Ensure that the puck is situated flat on the guide rail.

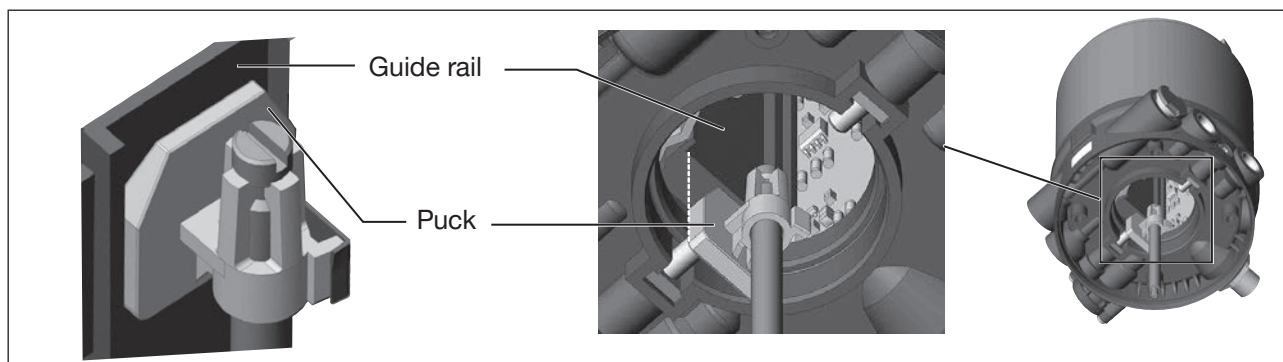

Figure 25: Aligning the puck

→ Press the positioner all the way down as far as the actuator and turn it into the required position.

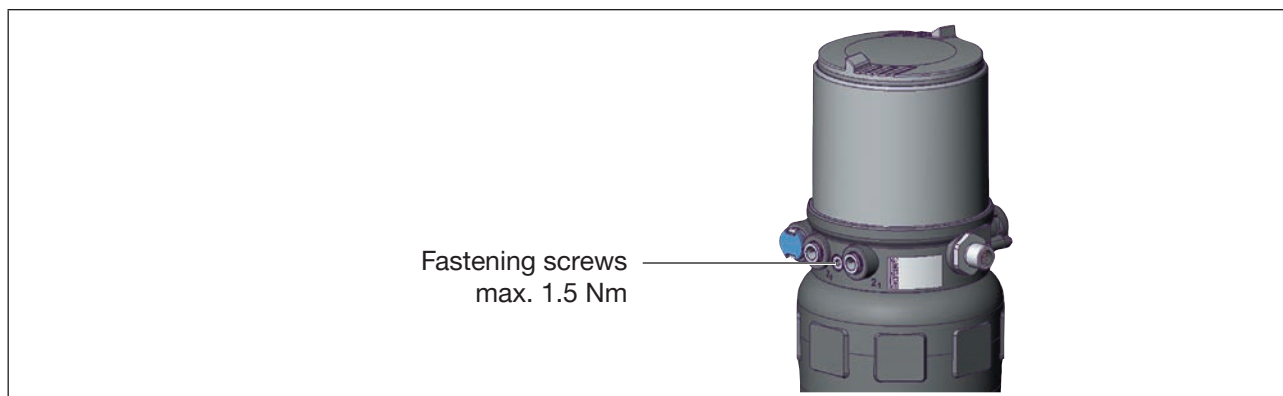

Figure 26: Installing the positioner



Ensure that the pneumatic connections of the positioner and those of the valve actuator are situated preferably vertically one above the other. If they are positioned differently, longer hoses may be required other than those supplied in the accessory kit.

NOTE

Too high torque when screwing in the fastening screw does not ensure degree of protection IP65 / IP67.

- ▶ The fastening screws may be tightened to a maximum torque of 1.5 Nm only.

→ Attach the positioner to the actuator using the two side fastening screws. In doing so, tighten the fastening screws hand-tight only (maximum torque: 1.5 Nm).

3. Install pneumatic connection between positioner and actuator

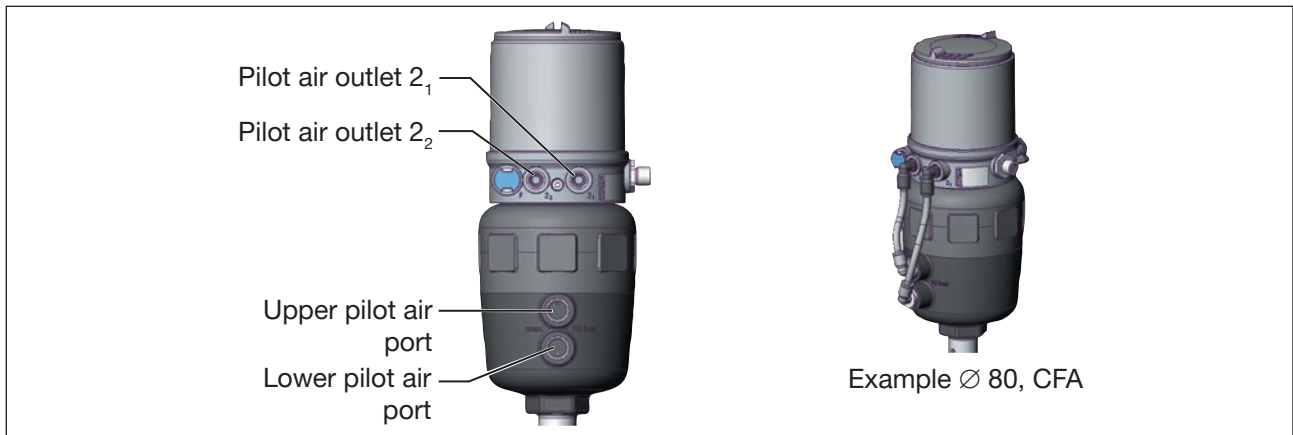

Figure 27: Installing the positioner

- Screw the plug-in hose connectors onto the positioner and the actuator.
- Using the hoses supplied in the accessory kit, make the pneumatic connection between the positioner and actuator with the following [“Table 17: Pneumatic connection to actuator, CFA”](#) or [“Table 18: Pneumatic connection to actuator, CFB”](#).

NOTE

Damage or malfunction due to ingress of dirt and moisture.

To observe degree of protection IP65 / IP67:

- ▶ In the case of actuator size $\varnothing 80$, $\varnothing 100$
connect the pilot air outlet which is not required to the free pilot air port of the actuator or seal with a plug.
- ▶ In the case of actuator size $\varnothing 125$
seal the pilot air outlet 22 which is not required with a plug and feed the free pilot air port of the actuator via a hose into a dry environment.

Control function A (CFA) Process valve closed in rest position (by spring force)		$\varnothing 80, \varnothing 100$		$\varnothing 125$
Actuator size				
Positioner	Pilot air outlet			
	Actuator			
Dry area				

Table 17: Pneumatic connection to actuator, CFA

Control function B (CFB) Process valve open in rest position (by spring force)		Ø 80, Ø 100		Ø 125
Actuator size		Ø 80, Ø 100		Ø 125
Positioner	Pilot air outlet			
Actuator	Upper pilot air port			
	Lower pilot air port			
Dry area				

Table 18: Pneumatic connection to actuator, CFB



"In rest position" means that the pilot valves of the positioner Type 8694 are isolated or not actuated.

8.4 Installation on rotary actuators from third party manufacturers

→ The magnetic transmitter for the sensor must be assembled on the spindle adapter and the adapter kit must be assembled on the actuator (see adapter kit assembly instructions).

→ Press the angle of rotation sensor into the sensor holder from above until it sits flush.

NOTE

Damage to the sensor cable.

▶ Ensure that the sensor cable is not damaged during assembly.

→ Press down the device as far as the actuator.

NOTE

Damage or malfunction due to ingress of dirt or moisture.

To observe the degree of protection IP65 or IP67:

▶ Tighten fastening screws only with a tightening torque of max. 0.5 Nm.

→ Attach the device to the actuator using both lateral fastening screws.

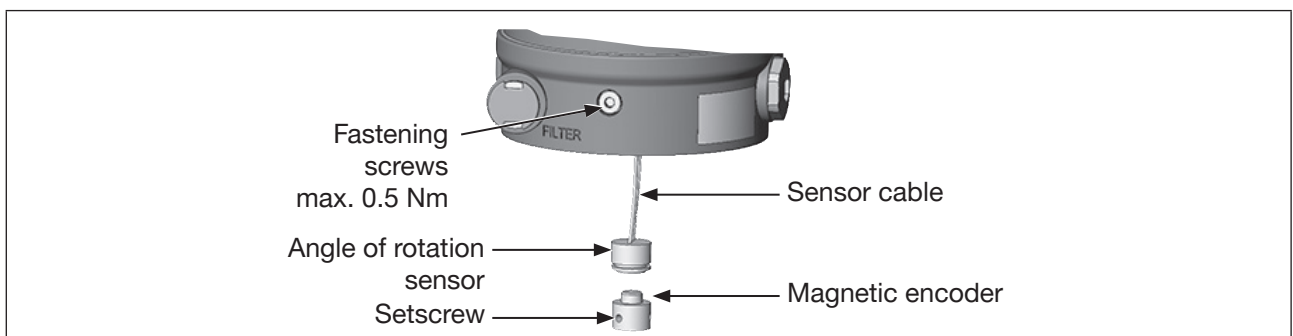

Figure 28: Installation on rotary actuators

8.5 Rotating the actuator module



The actuator module (positioner and actuator) can be rotated for straight seat valves and angle seat valves belonging to series 2300, 2301 and 27xx only.

The position of the connections can be aligned steplessly by rotating the actuator module (positioner and actuator) through 360°.



Process valves Type 2300, 2301 and 27xx: Only the entire actuator module can be rotated. The positioner cannot be rotated contrary to the actuator. The process valve must be in the open position for alignment of the actuator module.



DANGER

Risk of injury from high pressure in the equipment/device.

- ▶ Before working on equipment or device, switch off the pressure and deaerate/drain lines.

Procedure:

→ Clamp valve body in a holding device (only required if the process valve has not yet been installed).

NOTE

Damage to the seat seal or the seat contour.

- ▶ When removing the actuator module, ensure that the valve is in open position.

→ Control function A: Open process valve.

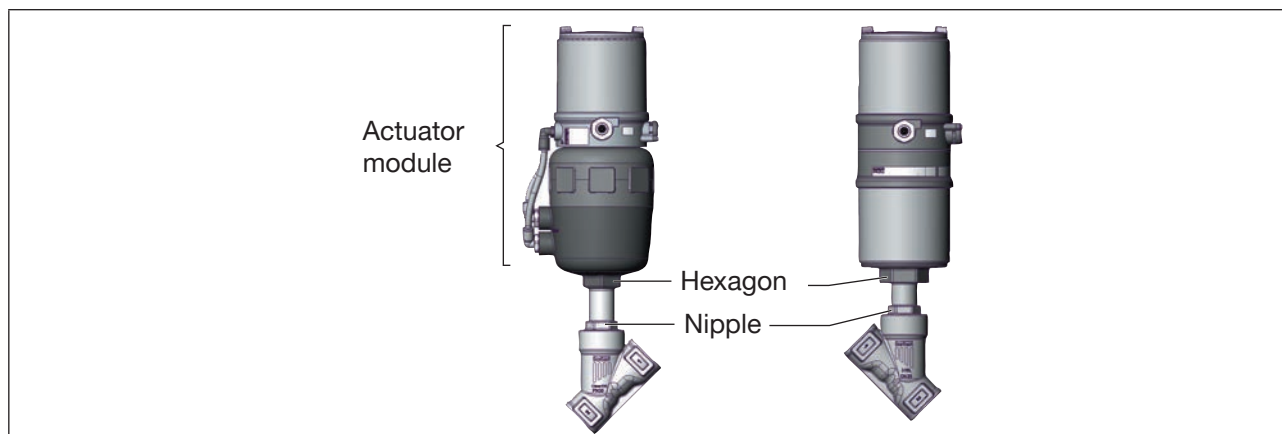

Figure 29: Rotating the actuator module

→ Using a suitable open-end wrench, counter the wrench flat on the nipple.

→ Place suitable open-end wrench on the hexagon of the actuator.

! WARNING

Risk of injury from discharge of medium and pressure.

If the direction of rotation is wrong, the body interface may become detached.

- ▶ Rotate the actuator module in the specified direction only (see “Figure 30”).

→ Rotate counter-clockwise (as seen from below) to bring the actuator module into the required position.

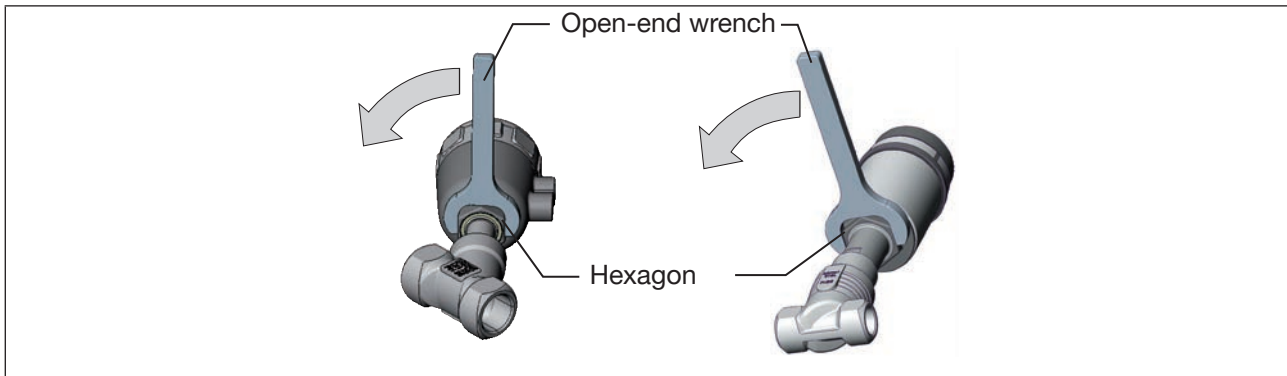

Figure 30: Rotating with special key / open-end wrench

8.6 Rotating the positioner for process valves belonging to series 26xx and 27xx

If the connecting cables or hoses cannot be fitted properly following installation of the process valve, the positioner can be rotated contrary to the actuator.

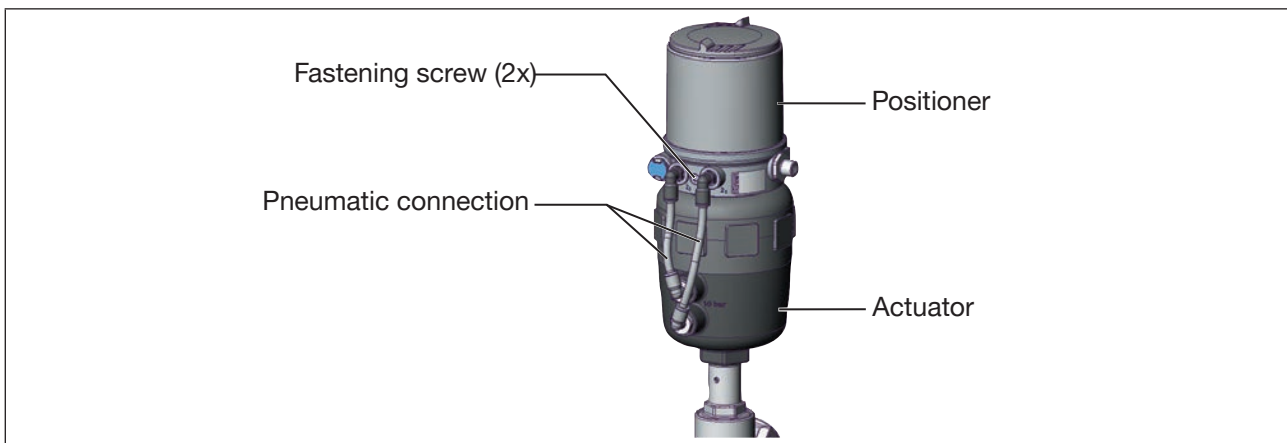

Figure 31: Rotating the positioner, series 26xx and 27xx

Procedure

- Loosen the pneumatic connection between the positioner and the actuator.
- Loosen the fastening screws (hexagon socket wrench size 2.5).
- Rotate the positioner into the required position.

NOTE

Too high torque when screwing in the fastening screw does not ensure degree of protection IP65 / IP67.

- ▶ The fastening screw may be tightened to a maximum torque of 1.5 Nm only.

- Tighten the fastening screws hand-tight only (maximum torque: 1.5 Nm).
- Re-attach the pneumatic connections between the positioner and the actuator. If required, use longer hoses.

9 PNEUMATIC INSTALLATION

9.1 Safety instructions



DANGER

Risk of injury from high pressure in the equipment/device.

- ▶ Before working on equipment or device, switch off the pressure and deaerate/drain lines.



WARNING

Risk of injury from improper installation.

- ▶ Installation may be carried out by authorized technicians only and with the appropriate tools.

Risk of injury from unintentional activation of the system and an uncontrolled restart.

- ▶ Secure system from unintentional activation.
- ▶ Following installation, ensure a controlled restart.

9.2 Connecting the device pneumatically

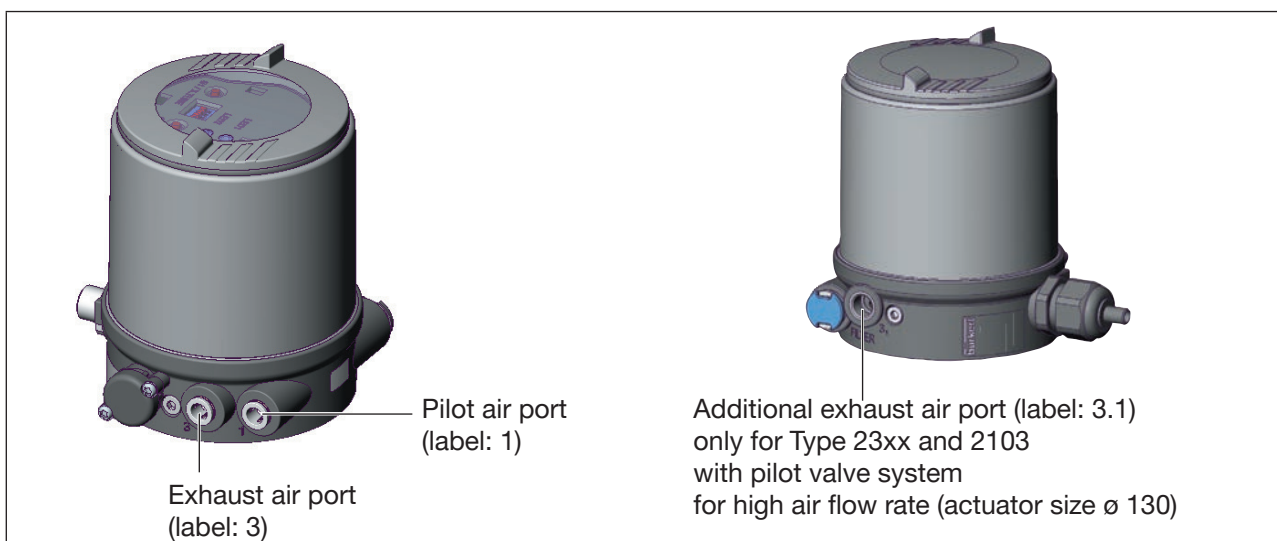

Figure 32: Pneumatic connection

Procedure:

- Connect the control medium to the pilot air port (1) (3 – 7 bar; instrument air, free of oil, water and dust).
- Attach the exhaust air line or a silencer to the exhaust air port (3) and, if available to the exhaust air port (3.1)



Caution: (Exhaust air concept):

- ▶ In compliance with degree of protection IP67, an exhaust air line must be installed in the dry area.

! Important information for the problem-free functioning of the device:

- ▶ The installation must not cause back pressure to build up.
- ▶ Select a hose for the connection with an adequate cross-section.
- ▶ The exhaust air line must be designed in such a way that no water or other liquid can get into the device through the exhaust air port (3) or (3.1).
- ▶ Keep the adjacent supply pressure **always** at least 0.5 – 1 bar above the pressure which is required to move the actuator to its end position. This ensures that the control behavior is not extremely negatively affected in the upper stroke range on account of too little pressure difference.
- ▶ During operation keep the fluctuations of the pressure supply as low as possible (max. ±10 %). If fluctuations are greater, the control parameters measured with the X.TUNE function are not optimum

9.3 Manual actuation of the actuator via pilot valves

9.3.1 Single-acting actuators (control function A and B)

The actuator can be moved without a power supply from the rest position to its end position and back again. To do this, the pilot valves must be actuated with a screwdriver.

NOTE!

The hand lever may be damaged if it is simultaneously pressed and turned.

- ▶ Do not press the hand lever when turning it.

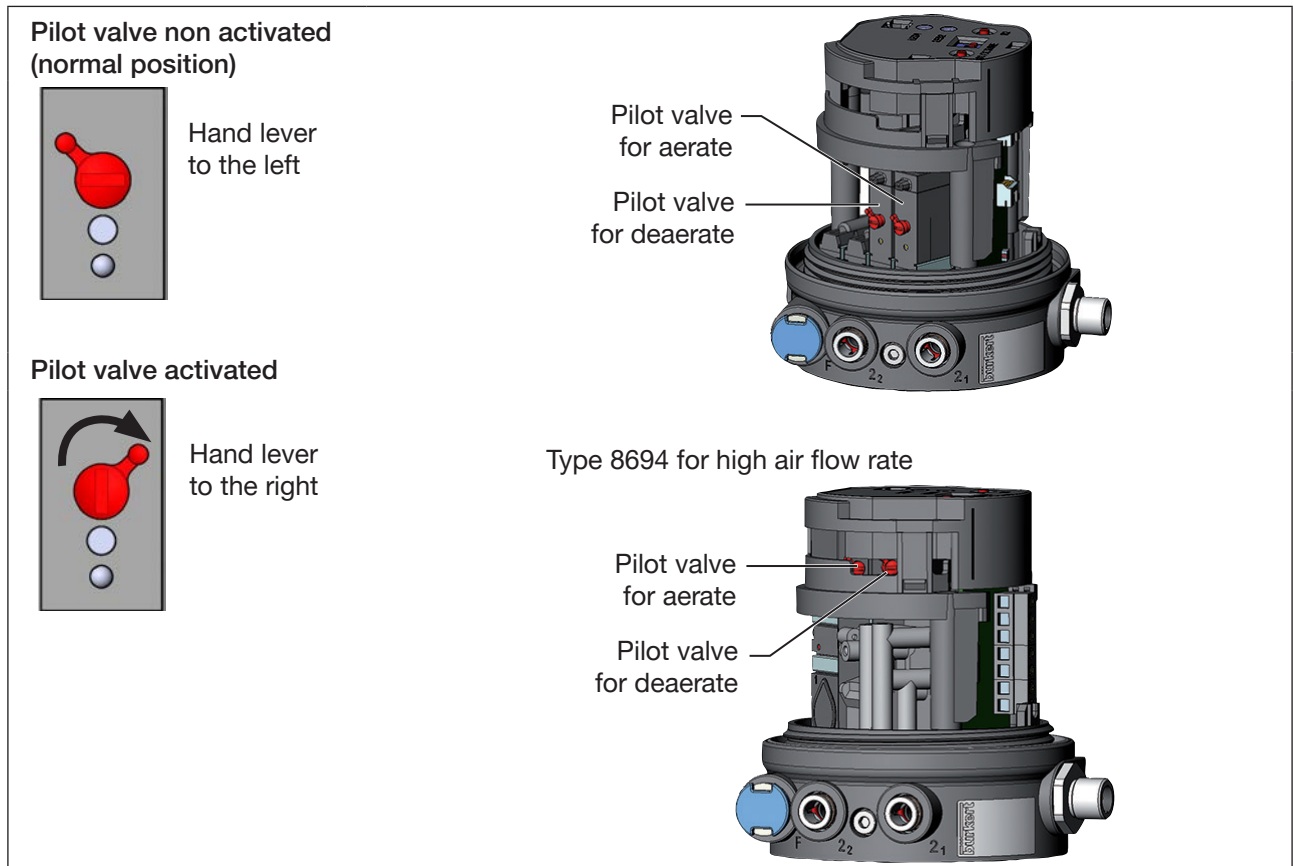

Figure 33: Pilot valves for aerate and deaerate the actuator

MAN 1000396587 EN Version: F Status: RL (released | freigegeben) printed: 07.04.2026

Move actuator to end position

Turn the hand levers to the right using a screwdriver.

Note: - do not press the hand levers when turning them
- observe the sequence as described below

<p>→ 1. Actuate hand lever pilot valve deaeration. → 2. Actuate hand lever pilot valve aeration. Both hand levers point to the right. The actuator moves to the end position.</p>	<div style="display: flex; justify-content: space-around;"> <div style="text-align: center;"> <p>1.</p>  </div> <div style="text-align: center;"> <p>2.</p>  </div> </div> <p style="text-align: center;">Type 8694 for high air flow rate</p> <div style="display: flex; justify-content: space-around;"> <div style="text-align: center;"> <p>2.</p>  </div> <div style="text-align: center;"> <p>1.</p>  </div> </div>
---	---

Figure 34: Move actuator to end position

Move actuator back to the rest position

Turn the hand levers to the left using a screwdriver.

Note: - do not press the hand levers when turning them
- observe the sequence as described below

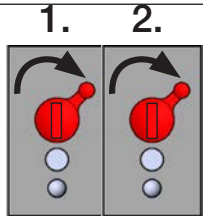
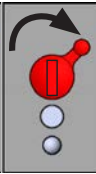
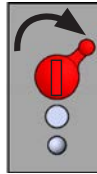
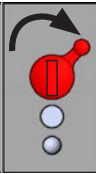
<p>→ 1. Actuate hand lever pilot valve aeration. → 2. Actuate hand lever pilot valve deaeration. Both hand levers point to the left (normal position). The actuator moves by spring force to the rest position.</p>	<div style="display: flex; justify-content: space-around;"> <div style="text-align: center;"> <p>2.</p>  </div> <div style="text-align: center;"> <p>1.</p>  </div> </div> <p style="text-align: center;">Type 8694 for high air flow rate</p> <div style="display: flex; justify-content: space-around;"> <div style="text-align: center;"> <p>1.</p>  </div> <div style="text-align: center;"> <p>2.</p>  </div> </div>
---	---

Figure 35: Move actuator back to the rest position

Caution: If the pilot valves are actuated, electrical control is not possible.
▶ Move hand levers to normal position before starting up the device.

MAN 1000396587 EN Version: F Status: RL (released | freigegeben) printed: 07.04.2026

10 ELECTRICAL INSTALLATION WITHOUT FIELDBUS

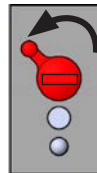
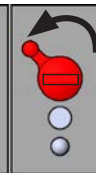
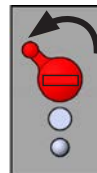
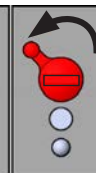
All electrical inputs and outputs of the device are not galvanically isolated from the supply voltage.

Two kinds of connections are used for the electrical bonding of the positioner:

- **Cable gland**
with cable gland M16 x 1.5 and screw-type terminals
- **Multi-pole**
with circular plug-in connector M12 x 1, 8-pin

10.1 Safety instructions



DANGER

Risk of electric shock.

- ▶ Before working on equipment or device, switch off the power supply and secure to prevent reactivation.
- ▶ Observe applicable accident prevention and safety regulations for electrical equipment.



WARNING

Risk of injury from improper installation.

- ▶ Installation may be carried out by authorized technicians only and with the appropriate tools.

Risk of injury from unintentional activation of the system and an uncontrolled restart.

- ▶ Secure system from unintentional activation.
- ▶ Following installation, ensure a controlled restart.

Minimum temperature rating of the cable to be connected to the field wiring terminals: 75 °C

10.2 Electrical installation with circular plug-in connector



DANGER

Risk of electric shock.

- ▶ Before working on equipment or device, switch off the power supply and secure to prevent reactivation.
- ▶ Observe applicable accident prevention and safety regulations for electrical equipment.

10.2.1 Designation of the contacts Type 8694

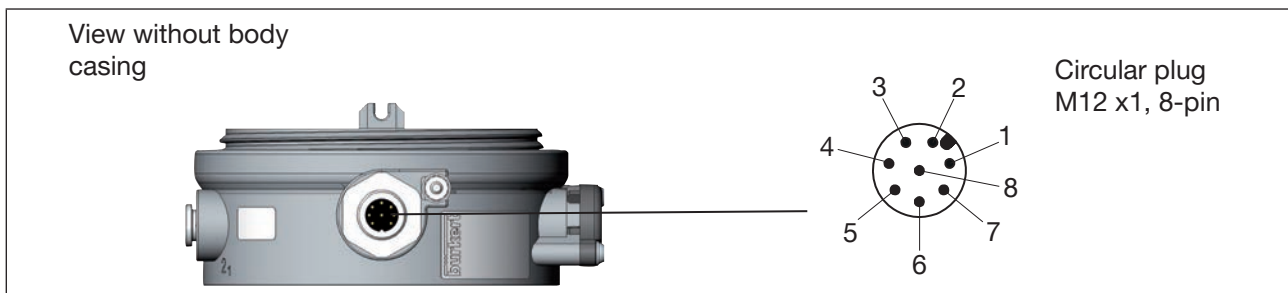

Figure 36: Circular plug M12 x 1, 8-pin

10.2.2 Connection of the positioner Type 8694

→ Connect the pins according to the model of the positioner.

Input signals of the control center (e.g. PLC), circular plug M12 x 1, 8-pin

Pin	Wire color ²³⁾	Configuration	External circuit / signal level
1	white	Set-point value + (0/4 – 20 mA)	
2	brown	Set-point value GND	
5	grey	Digital input +	
6	pink	Digital input GND	

Table 19: Pin assignment, input signals of the control center, circular plug M12 x 1, 8-pin

Connection type 3-wire or 4-wire (setting via communication software):

Connection type 4-wire (factory setting)	Connection type 3-wire
<p>The set-point value input is designed as a differential input, i.e. the GND lines of the set-point value input and the supply voltage are not identical.</p> <p>Note: If the GND signals of the set-point value input and the supply voltage are connected, the 3-wire connection type must be set in the software.</p>	<p>The set-point value input is related to the GND line of the supply voltage, i.e. setpoint input and supply voltage have a common GND line.</p>

Table 20: Connection type

MAN 1000396587 EN Version: F Status: RL (released | freigegeben) printed: 07.04.2026

²³⁾ The indicated colors refer to the connecting cable available as an accessory (919061)

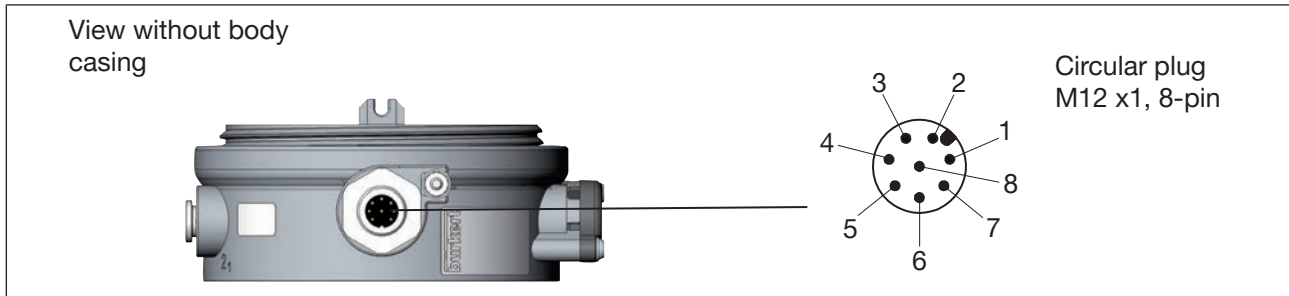

Figure 37: Circular plug M12 x 1, 8-pin

Output signals to the control center (e.g. PLC), circular plug M 12 x 1, 8-pin (required for analogue output variant only)

Pin	Wire color ²⁴⁾	Configuration	External circuit / signal level
8	red	Analogue position feedback +	8 + (0/4 - 20 mA)
7	blue	Analogue position feedback GND	7 GND

Table 21: Pin assignment, output signals of the control center, circular plug M12 x 1, 8-pin

Operating voltage (circular plug M12 x 1, 8-pin)

Pin	Wire color ²⁴⁾	Configuration	External circuit
4	yellow	+ 24 V	
3	green	GND	

Table 22: Pin assignment, operating voltage (circular plug M12 x 1, 8-pin)

When the supply voltage is applied, the positioner is operating.

→ Make the required basic settings and actuate the automatic adjustment of the positioner, as described in the chapter entitled [“14 Start-up”](#).

MAN 1000396587 EN Version: F Status: RL (released | freigegeben) printed: 07.04.2026

²⁴⁾ The indicated colors refer to the connecting cable available as an accessory (919061)

10.3 Electrical installation with cable gland

DANGER

Risk of electric shock.

- ▶ Before working on equipment or device, switch off the power supply and secure to prevent reactivation.
- ▶ Observe applicable accident prevention and safety regulations for electrical equipment.

NOTE

Breakage of the pneumatic connection pieces due to rotational impact.

- ▶ When unscrewing and screwing in the body casing, do not hold the actuator of the process valve but the basic housing.

→ The screw-type terminals can be accessed by unscrewing the body casing (stainless steel).

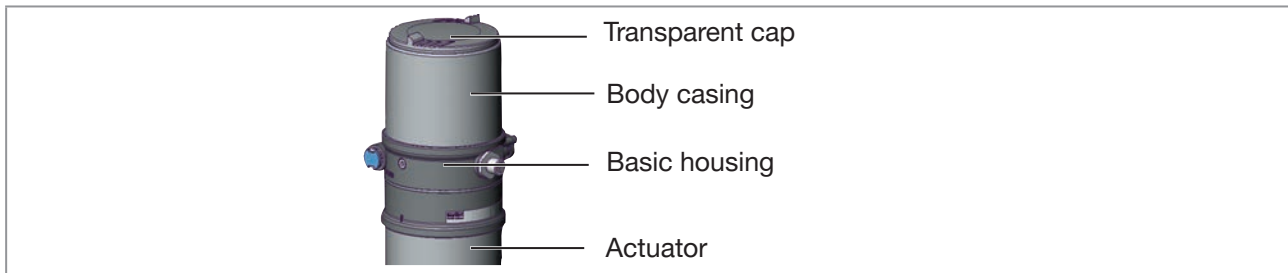

Figure 38: Open positioner

→ Push the cables through the cable gland.

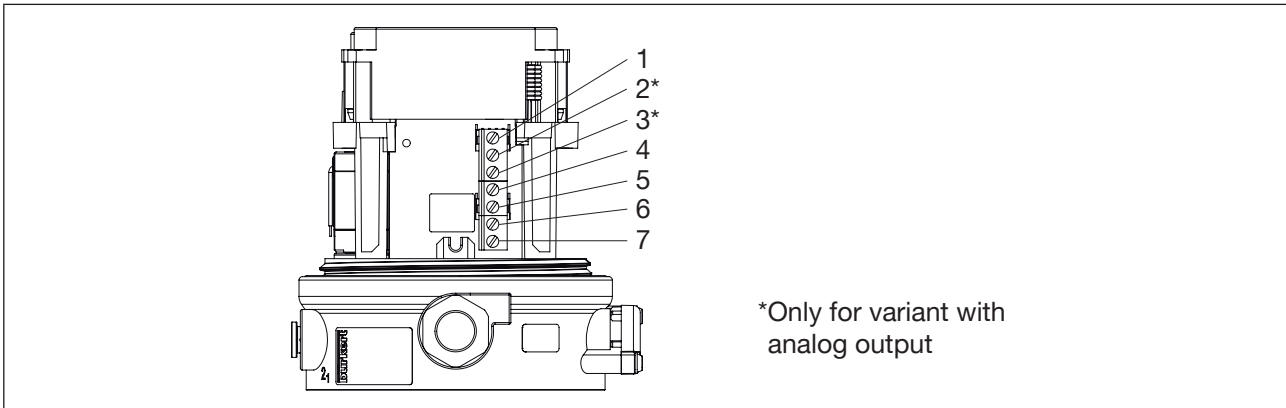

Figure 39: Connection of screw-type terminals

→ Connect the positioner according to the following tables:

Input signals from the control centre (e.g. PLC)

Terminal	Configuration	External circuit
4	Set-point value +	4 ○ ——— + (0/4 – 20 mA) 5 ○ ——— GND see table "Connection type 3-wire or 4-wire"
5	Set-point value GND	
1	Digital input +	1 ○ ——— + 0 – 5 V (logical 0) with reference to terminal 7 (GND) 10 – 30 V (logical 1)

Table 23: Assignment of screw-type terminals, input signals of the control center, cable gland

Connection type 3-wire or 4-wire (setting via communication software):

Connection type 4-wire (factory setting)	Connection type 3-wire
The set-point value input is designed as a differential input, i.e. the GND lines of the set-point value input and the supply voltage are not identical. Note: If the GND signals of the set-point value input and the supply voltage are connected, the 3-wire connection type must be set in the software.	The set-point value input is related to the GND line of the supply voltage, i.e. setpoint input and supply voltage have a common GND line.

Table 24: Connection type

Output signals to the control center (e.g. PLC; for analog output option only)

Terminal	Configuration	External circuit
2	Analogue position feedback +	2 + (0/4 - 20 mA)
3	Analogue position feedback GND	3 GND

Table 25: Assignment of screw-type terminals, output signals to the control center, cable gland

Operating voltage

Terminal	Configuration	External circuit
6	Operating voltage +	 24 V DC ± 25 % max. residual ripple 10 %
7	Operating voltage GND	

Table 26: Assignment of screw-type terminals, operating voltage, cable gland

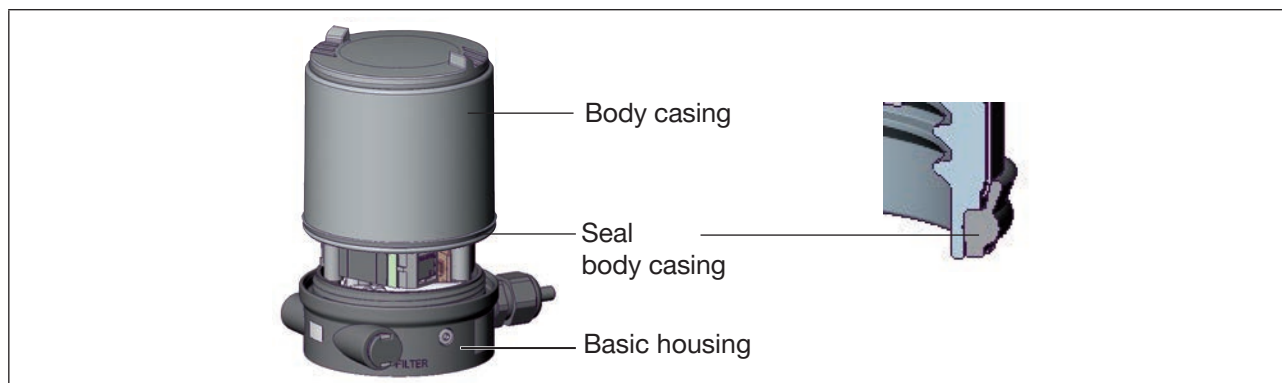

Figure 40: Position of the seal in the body casing

→ Check that the seal is correctly positioned in the body casing.

NOTE

Breakage of the pneumatic connection pieces due to rotational impact.

- ▶ When unscrewing and screwing in the body casing, do not hold the actuator of the process valve but the basic housing.

Damage or malfunction due to penetration of dirt and humidity.

To ensure degree of protection IP65 / IP67:

- ▶ Tighten the union nut on the cable gland according to the cable size or dummy plugs used (approx. 1.5 Nm).
- ▶ Screw the body casing in all the way.

→ Tighten union nut on the cable gland (torque approx. 1.5 Nm).

→ Close the device (assembly tool: 674077²⁵⁾).

²⁵⁾ The assembly tool (674077) is available from your Bürkert sales office.

11 ELECTRICAL INSTALLATION, IO-LINK

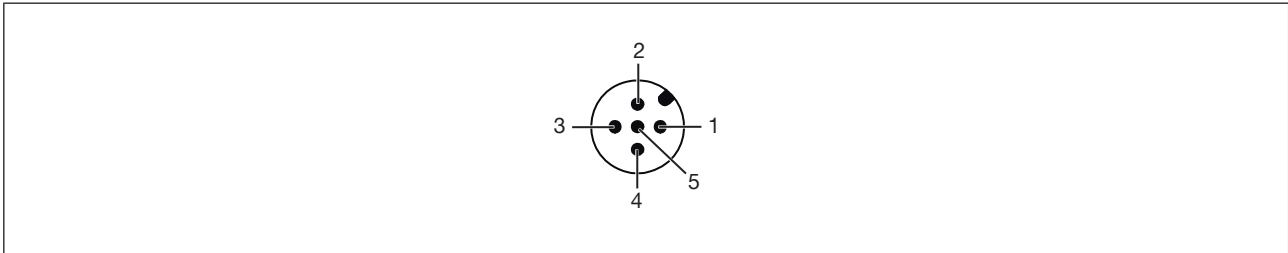

Figure 41: Pin assignment

Pin assignment Port Class A

Pin	Designation	Configuration	
1	L +	24 V DC	System supply
2	I/Q	NC	Not used
3	L -	0 V (GND)	System supply
4	C/Q	IO-Link	Communication
5	NC	NC	Not used

Table 27: Pin assignment Port Class A

Pin assignment Port Class B

Pin	Designation	Configuration	
1	L +	24 V DC	System supply
2	P24	24 V DC	Actuator supply
3	L -	0 V (GND)	System supply
4	C/Q	IO-Link	Communication
5	N24	0 V (GND)	Actuator supply

Table 28: Pin assignment Port Class B

12 ELECTRICAL INSTALLATION, BÜS

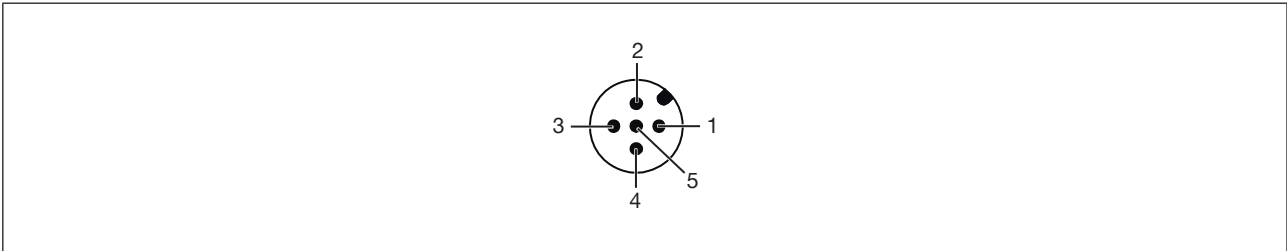

Figure 42: Pin assignment

Pin	Wire color	Configuration
1	CAN plate/shielding	CAN plate/shielding
2	red	+24 V DC \pm 25%, max. residual ripple 10%
3	black	GND / CAN_GND
4	white	CAN_H
5	blue	CAN_L

Table 29: Pin assignment

! For electrical installation with bÜS network, note:
 Use a 5-pin round plug and shielded 5-core cable.
 The shielding in the device is not connected to the functional earth.

13 ELEKTRICAL INSTALLATION, AS-INTERFACE

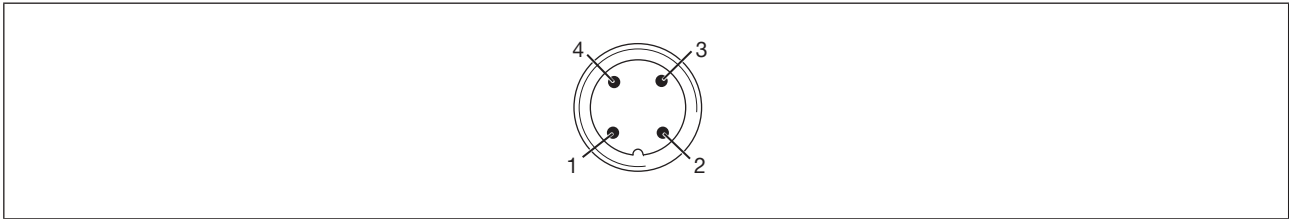

Figure 43: Pin assignment

Pin	Designation	Configuration
1	Bus +	Bus line AS-Interface +
2	AUX –	Actuator supply – (optional, only for variant with additional actuator supply (AUX Power))
3	Bus –	Bus line AS-Interface –
4	AUX +	Actuator supply + (optional, only for variant with additional actuator supply (AUX Power))

Table 30: Pin assignment

13.1 Connecting the device with multi-pole cable and flat cable terminal

As an alternative to the bus connection model with 4-pole circular plug, there is the positioner with multi-pole cable (M12 circular plug) and flat cable terminal. The wiring diagram of the circular plug corresponds to the bus connection of the M12 4-pole circular plug and can easily be connected to the flat cable terminal.



Figure 44: Positioner 8694 with multi-pole cable and flat cable terminal

Calculated bus line length:

When designing the system, consider the length of the cable which is fed directly to the positioner for the maximum bus line length (multi-pole cable and cable inside: 1.0 m).

Example calculation:

When using 62 positioner with multi-pole cable, the AS-Interface flat cable may still be maximum 38 m long.

$$100 \text{ m} - 62 \times 1.0 \text{ m} = 38 \text{ m}$$

If the calculated bus line length of 100 m is exceeded, a commercially available AS-Interface repeater can be used.

Handling the flat cable terminal

The multi-pole cable features a ribbon cable terminal - with M12 plug-in connector branch circuit - for AS-Interface flat cable. The flat cable terminal contacts the AS-Interface flat cable by means of penetration technology which allows installation by “clipping in” the AS-Interface flat cable without cutting and without removing insulation.

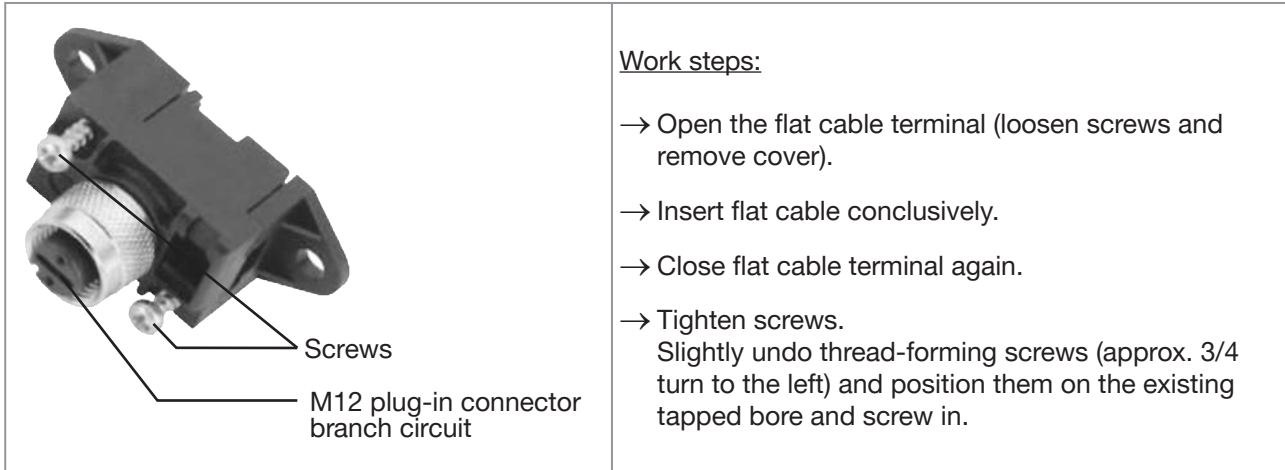

Figure 45: Flat cable terminal

When the supply voltage is applied, the positioner is operating.

→ Make the required basic settings and actuate the automatic adjustment of the positioner, as described in the chapter entitled Start-up.

14 START-UP

14.1 Safety instructions



DANGER

Risk of injury from high pressure in the equipment/device.

- ▶ Before working on equipment or device, switch off the pressure and deaerate/drain lines.



WARNING

Risk of injury from improper operation.

Improper operation may result in injuries as well as damage to the device and the area around it.

- ▶ Before start-up, ensure that the operating personnel are familiar with and completely understand the contents of the operating instructions.
- ▶ Observe the safety instructions and intended use.
- ▶ Only adequately trained personnel may operate the equipment/the device.

14.2 Specifying the standard settings

The basic settings of the positioner are implemented at the factory.



To adjust the positioner to local conditions, the *X.TUNE* function must be run following installation.

14.2.1 Running the automatic adjustment *X.TUNE*



WARNING

Danger due to the valve position changing when the *X.TUNE* function is running.

When the *X.TUNE* is running under operating pressure, there is an acute risk of injury.

- ▶ Never run *X.TUNE* while a process is running.
- ▶ Take appropriate measures to prevent the equipment from being accidentally actuated.

NOTE

Avoid maladjustment of the controller due to an incorrect pilot pressure or applied operating medium pressure.

- ▶ Run *X.TUNE* **whenever** the pilot pressure (= pneumatic auxiliary energy) is available during subsequent operation.
- ▶ Run the *X.TUNE* function preferably **without** operating medium pressure to exclude interference caused by flow forces.



To run *X.TUNE*, the positioner must be in the AUTOMATIC operating status (DIP switch 4 = OFF).

NOTE

Breakage of the pneumatic connection pieces due to rotational impact.

- ▶ When unscrewing and screwing in the body casing or transparent cap, do not hold the actuator of the process valve but the basic housing.

→ To operate the DIP switches, unscrew the transparent cap

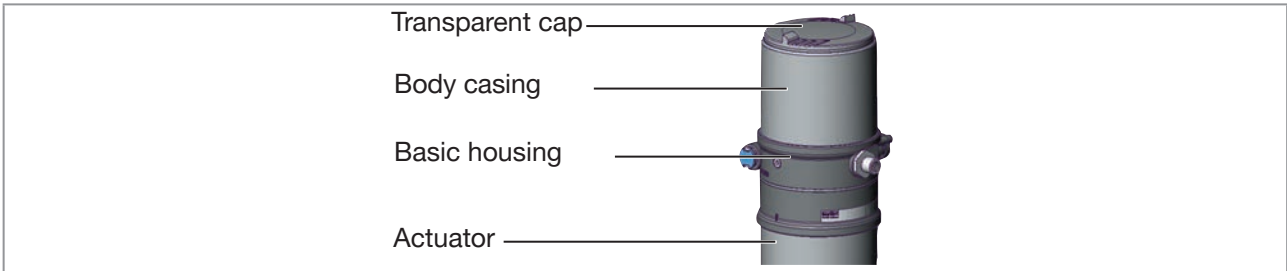

Figure 46: Open positioner

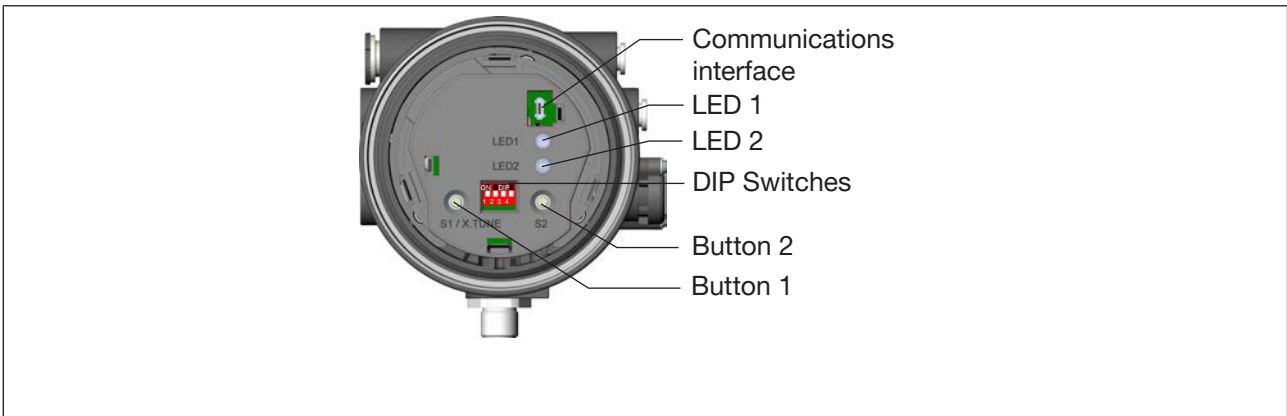

Figure 47: Automatic adjustment X.TUNE

! To run X.TUNE, the positioner must be in the AUTOMATIC operating status (DIP switch 4 = OFF).

→ Start the X.TUNE by pressing button 1²⁶⁾ for 5 s.

LED 2 flashes at 5 Hz. The device is in the NAMUR status function check, LED 1 lights orange.

If the X.TUNE is successfully completed, the NAMUR status is reset again. The changes are automatically transferred to the memory (EEPROM) provided the X.TUNE function is successful.

When LED 1 lights red after X.TUNE:

→ Execute X.TUNE again.

→ Perform a device restart if necessary.

²⁶⁾ The X.TUNE can also be started via communications software.

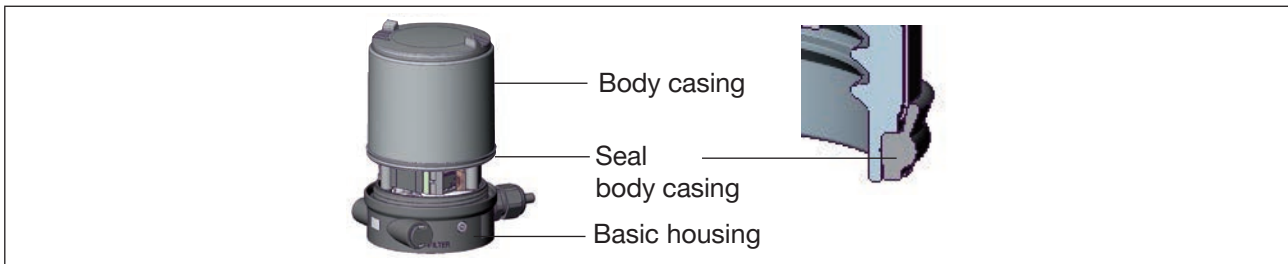

Figure 48: Position of the seal in the body casing

NOTE

Breakage of the pneumatic connection pieces due to rotational impact.

- ▶ When unscrewing and screwing in the body casing or transparent cap, do not hold the actuator of the process valve but the basic housing.

Damage or malfunction due to penetration of dirt and humidity.

- ▶ To observe degree of protection IP65 / IP67, screw the transparent cap in all the way.

→ Close the device (assembly tool: 674077²⁷⁾).

14.3 Setting with Bürkert Communicator

The Bürkert Communicator can be used to make all settings on the device.



The settings in the Bürkert Communicator can be found in the operating manual.

14.3.1 Connecting IO-Link device with Bürkert Communicator

Required components:

- Communications software: Bürkert Communicator for PC
- USB-büS interface set (see accessories)
- büS adapter for büS service interface (see accessories)
- If necessary, a büS cable extension (see accessories)

NOTE

Breakage of the pneumatic connection pieces due to rotational impact.

- ▶ When opening or closing the device, do not press against the actuator, but against the basic housing.

→ Screw off the transparent cap by turning counterclockwise.

²⁷⁾ The assembly tool (674077) is available from your Bürkert sales office.

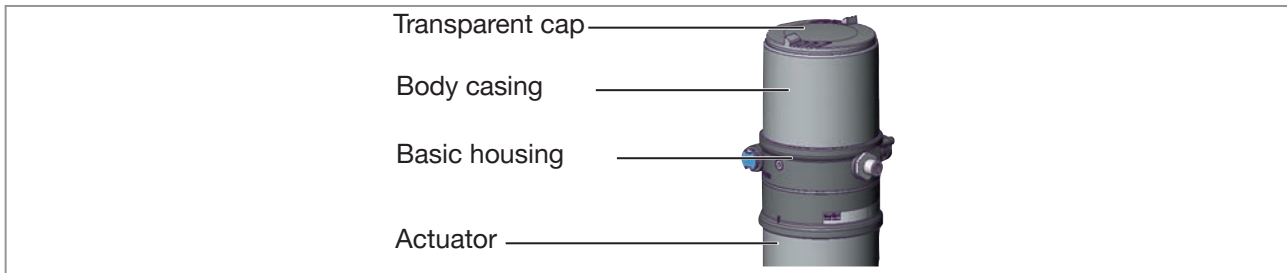

Figure 49: Open positioner

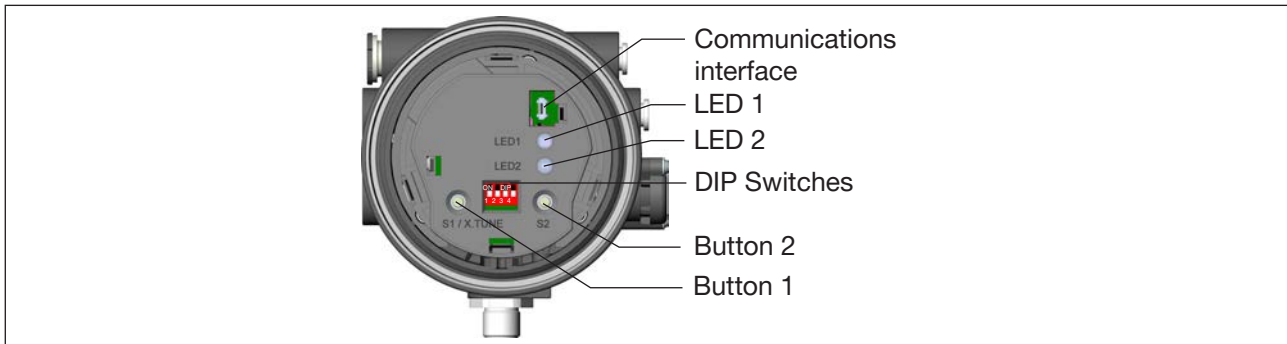

Figure 50: Automatic adjustment X.TUNE

- Insert micro USB plug in communications interface.
- Establish connection to PC with USB-büS interface set.
- Starting Bürkert Communicator.
- Implementing settings.

14.3.2 Connecting büS device with Bürkert Communicator

Required components:

- Communications software: Bürkert Communicator for PC
- USB-büS interface set (see accessories)

- Establish connection to PC with USB-büS interface set.
- Starting Bürkert Communicator.
- Implementing settings.

15 IO-LINK

15.1 Information, IO-Link

IO-Link is an internationally standardized IO technology (IEC 61131-9) to enable sensors and actuators to communicate.

IO-Link is a point-to-point communication with 3-wire connection technology for sensors and actuators and unshielded standard sensor cables.

To ensure clear communication, the IO-Link devices should not be parameterised simultaneously by the higher-level controller (PLC) via the IO-Link master and with the Bürkert Communicator (via the service

15.2 Technical specifications, IO-Link

IO-Link specifications	V1.1.2
Supply	via IO-Link (M12 x 1, 5-pin, A-coded)
Port Class	A or B
SIO mode	no
IODD file	see Internet
VendorID	0x0078, 120
DeviceID	see IODD file
ProductID	8694
Transmission speed	COM3 (230.4 kbit/s)
PD Input Bits	80
PD Output Bits	40
M-sequence Cap.	0x0D
Min. cycle time	5 ms
Data storage	Yes
Max. cable length	20 m

15.2.1 Configuration of the fieldbus

The required start-up files and the description of the process data and acyclic parameters are available on the Internet.



Download from:
www.burkert.com / Type 8694 / Software

16 BÜS

16.1 Information, büS

büS is a system bus developed by Bürkert with a communication protocol based on CANopen.

16.2 Configuration of the fieldbus

The required start-up files and the description of objects are available on the Internet.



Download from:

www.burkert.com / Type 8694 / Software

17 AS-INTERFACE

17.1 Information, AS-Interface

AS-Interface (Actuator Sensor Interface) is a field bus system which is used primarily for networking binary sensors and actuators (slaves) with a higher-level control (master). The unshielded two-wire line is used to transmit both the information (data) and the energy to supply the actuators and sensors.

17.2 Length of the bus line

The bus line may have a maximum length of 100 m. During the design phase, consider all AS-Interface lines in an AS-Interface section, i.e. even the stub lines to the individual slaves.

The development stage which is actually possible depends on the sum of all the individual operating currents per positioner which are supplied on a common AS-Interface bus segment via the bus.



- Observe the maximum power supply ≤ 8 A via certified AS-Interface power supply units. Details see AS-Interface specification.
- Note the optional model “AS-Interface with external power supply” to relieve the AS-Interface bus segment.
- Use cables according to the AS-Interface specification. If other cables are used, the maximum bus line length will change.

17.3 Technical data for AS-Interface PCBs

	Version Profile S-7.3.4	Version Profile S-7.A.5
Supply	via AS-Interface	via AS-Interface
Outputs	16 bit set-point value	16 bit set-point value
Inputs	-	16 bit feedback
Certification	Certificate no. xxxx after version 3.0	Certificate no. xxxxx after version 3.0

Table 31: Technical data

17.4 Programming data

	Version Profile S-7.3.4	Version Profile S-7.A.5
E/A-Konfiguration	7 hex	7 hex
ID-Code	3 hex (analog profile)	A hex
Extended ID Code 1	F hex (Default value, can be changed by the user)	7 hex
Extended ID Code 2	4 hex	5 hex
Profile	S-7.3.4	S-7.A.5

Table 32: Programming data

Bit configuration

1. Output set-point value (Value range 0 – 10.000, is equivalent to 0 – 100 %)
2. Input feedback18) (Value range 0 – 10.000 (16 Bit, signed integer), is equivalent to 0 – 100 %)
Values below 0 (0.0 %) and above 10,000 (100.0 %) are possible due to mechanical tolerances.
Example: Position -1.0 % corresponds to -100 = 0xFF9C

Byte 2								Byte 1							
D15	D14	D13	D12	D11	D10	D9	D8	D7	D6	D5	D4	D3	D2	D1	D0
Parameter bit		P3			P2			P1			P0				
Output		not used			not used			not used			not used				

Table 33: Bit configuration

17.5 LED status display AS-Interface

NOTE

Breakage of the pneumatic connection pieces due to rotational impact.

- ▶ When unscrewing and screwing in the body casing, do not hold the actuator of the process valve but the connection housing.

The LED status display indicates the bus status (LED green and red).

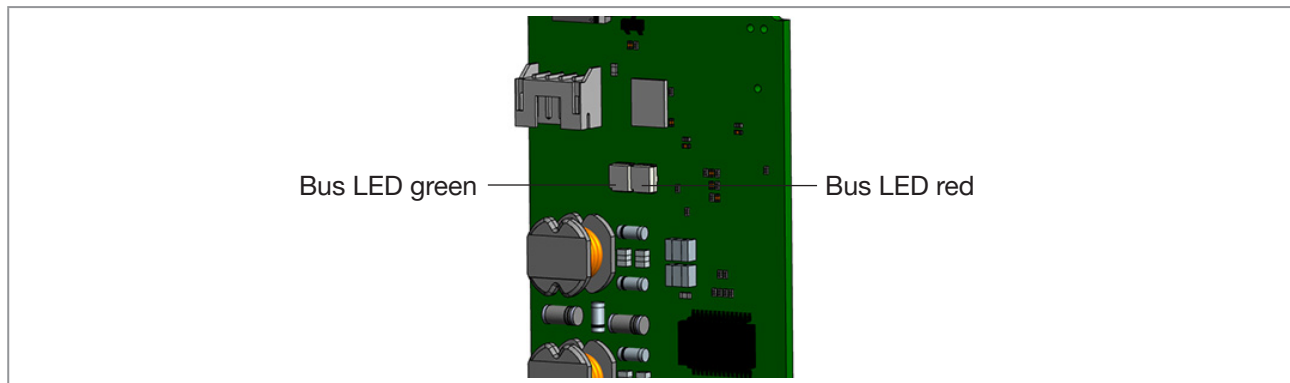

Figure 51: LED status display AS-Interface

LED green	LED red	
off	off	POWER OFF
on	on	No data traffic (expired Watch Dog at slave address does not equal 0)
on	off	OK
flashing	on	Slave address equals 0
on	flashing	Serious periphery error
flashing	flashing	Device error (peripheral error)

Table 34: LED Status Display AS-Interface

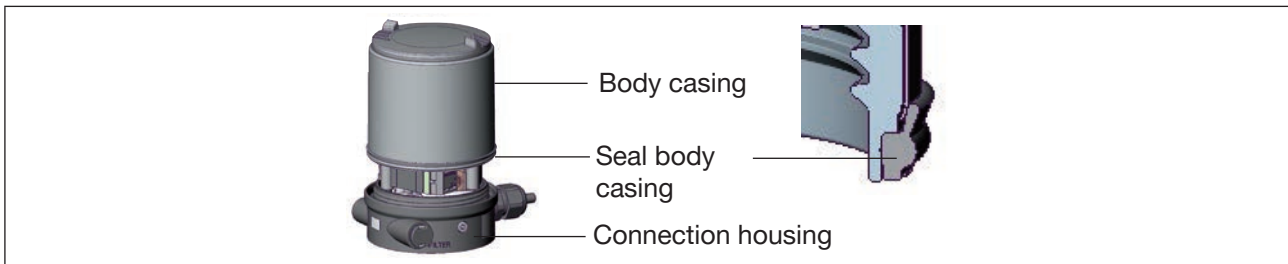

Figure 52: Position of the seal in the body casing

→ Check that the seal is correctly positioned in the body casing.

NOTE

Breakage of the pneumatic connection pieces due to rotational impact.

- ▶ When unscrewing and screwing in the body casing, do not hold the actuator of the process valve but the connection housing.

Damage or malfunction due to penetration of dirt and humidity.

- ▶ To observe degree of protection IP65 / IP67, screw the transparent cap in all the way.

→ Close the device (assembly tool: 674077).

18 OPERATION AND FUNCTION

The positioner type 8694 has different basic and additional functions which can be configured and parameterized via the DIP switches or the communications software.

18.1 Basic functions

The following basic functions can be activated via the DIP switches (*CUTOFF* and *CHARACT*) or changed (*DIR.CMD*).

The parameters for the sealing function (*CUTOFF*) and characteristic correction (*CHARACT*) are set using the communication software.

Function	Description	DIP Switches	OFF	ON
Reversal of the effective direction set-point value <i>DIR.CMD</i>	Effective direction between input signal and set-point position	1	rise	fall
Sealing function <i>CUTOFF</i>	Sealing function for position controller	2	Sealing function off	Sealing function on
Characteristic correction <i>CHARACT</i>	Selection of the Transfer Characteristic between Input Signal and Stroke (Correction Characteristic)	3	Linear characteristic	Correction characteristic

Table 35: Basic functions of DIP switches

The following basic functions can be activated or changed with the buttons or the communications software.

Function	Description	Factory setting
Standard signal ²⁸⁾ <i>INPUT</i>	Entry of the standard signal input for the set-point value	4 – 20 mA, 4-wire
Reset to factory settings <i>RESET</i>	Reset to factory settings	
Automatic calibration of the position controller <i>X.TUNE</i>	Automatic adjustment of the positioner to the relevant operating conditions	

Table 36: Basic functions

²⁸⁾ Only with communications software

18.1.1 *DIR.CMD* - Reversal of the effective direction of the positioner set-point value

You can use this function to adjust the effective direction between the input signal (INPUT) and the nominal position of the actuator.

Factory setting: DIP switch set to OFF (ascending)

DIP Switches	Position	Function
1	ON	Reversal of the effective direction of the set-point value (<i>DIR.CMD</i>) (set-point value 20 – 4 mA corresponds to position 0 – 100 %), fall
	OFF	Normal effective direction of the set-point value (set-point value 4 – 20 mA corresponds to position 0 – 100 %), rise

Table 37: *DIR.CMD* DIP switch 1

! The effective direction (*DIR.CMD*) can only be changed with DIP switch 1 in the positioner.

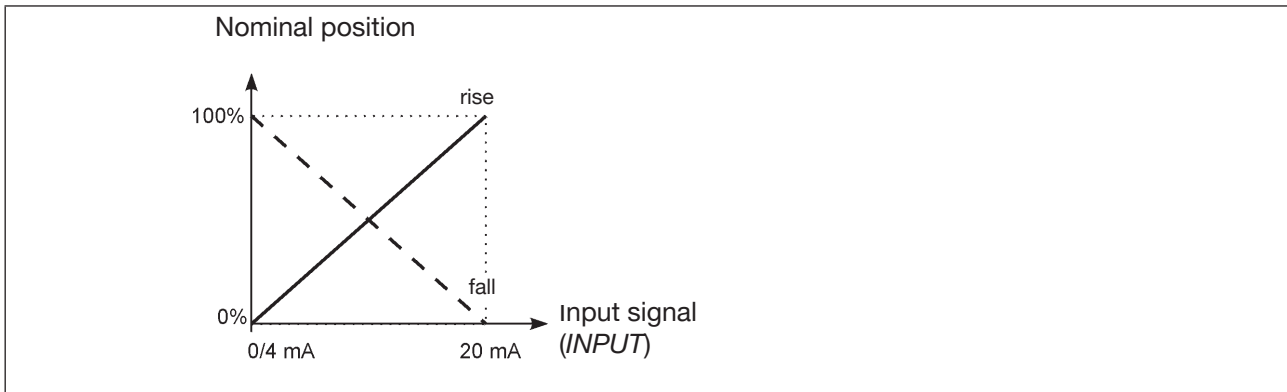

Figure 53: *DIR.CMD* graph

MAN 1000396587 EN Version: F Status: RL (released | freigegeben) printed: 07.04.2026

18.1.2 CUTOFF - Sealing function for the positioner

This function causes the valve to be sealed outside the control range.

Control mode resumes at a hysteresis of 1%.

Factory setting: DIP switch 2 set to OFF (no sealing function)

DIP Switches	Position	Function
2	ON	Sealing function active. The valve completely closes below 2 % ²⁹⁾ and opens above 98 % of the set-point value (CUTOFF)
	OFF	No sealing function

Table 38: DIP switch 2

The communications software can be used to change the limits for the position set-point value as a percentage.



The switching position of the DIP switches in the positioner has priority over the communications software, i.e. settings of the sealing function (CUTOFF) which are modified with the communications software are only active if DIP switch 2 in the positioner is set to ON.

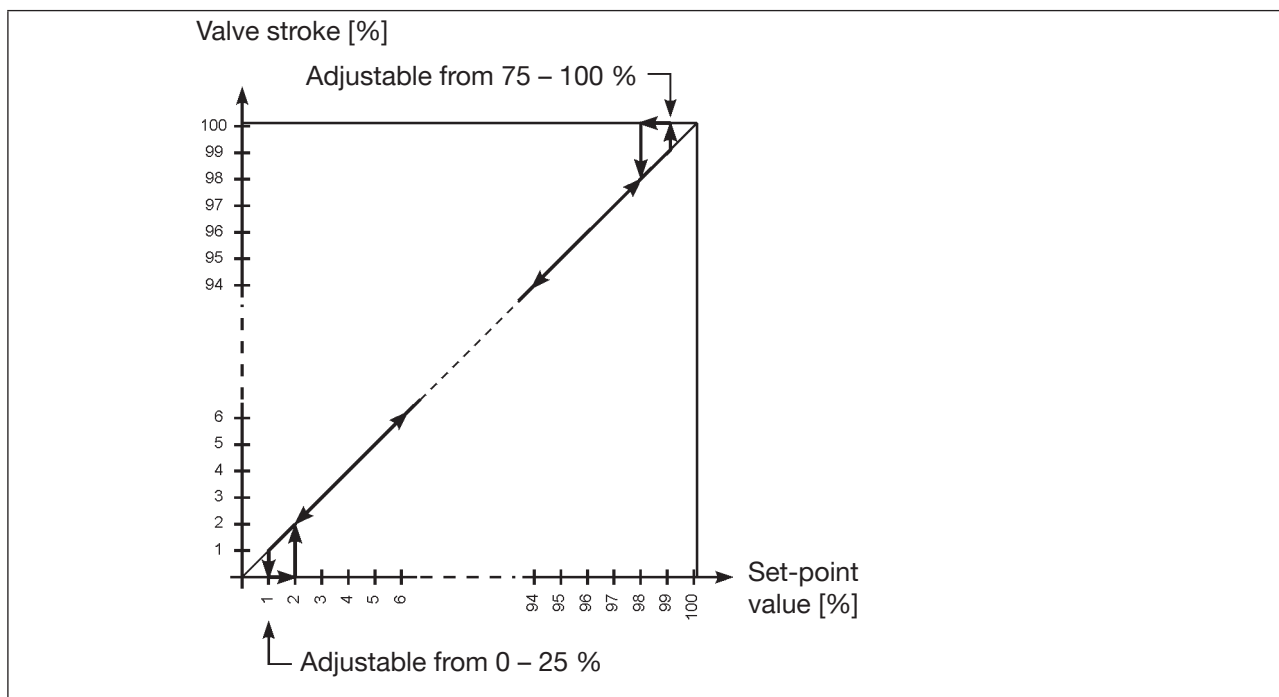

Figure 54: CUTOFF graph

²⁹⁾ Factory setting can be changed with communications software.

18.1.3 CHARACT - Characteristic correction between input signal (position set-point value) and stroke

Characteristic (customer-specific characteristic)

This function can be used to activate a transfer characteristic with respect to set-point value (set-point position) and valve stroke for correction of the flow-rate or operating characteristic.



The transfer characteristic can be changed via the communications software only.

Factory setting: DIP switch 3 set to OFF (linear)

DIP Switches	Position	Function
3	ON	Correction characteristic for adjustment of the operating characteristic (linearization of the process characteristic <i>CHARACT</i>) ³⁰⁾
	OFF	Linear characteristic

Table 39: DIP switch 3



The switching position of the DIP switches in the positioner has priority over the communications software, i.e. settings of the correction characteristic (*CHARACT*) which are modified with the communications software are only active if DIP switch 3 in the positioner is set to ON.

Characteristics which can be selected via the communications software:

Characteristic	Description
linear	Linear characteristic
1 : 25	Equal percentage characteristic 1 : 25
1 : 33	Equal percentage characteristic 1 : 33
1 : 50	Equal percentage characteristic 1 : 50
25 : 1	Inversely equal percentage characteristic 25 : 1
33 : 1	Inversely equal percentage characteristic 33 : 1
55 : 1	Inversely equal percentage characteristic 55 : 1
FREE	User-defined characteristic, freely programmable via nodes

Table 40: Selection of characteristics

³⁰⁾ The characteristic type can be changed with the communications software only.

The flow characteristic $k_v = f(s)$ indicates the flow-rate of a valve, expressed by the value k_v as a function of the stroke s of the actuator spindle. It is determined by the design of the valve seat and the seat seal. In general two types of flow characteristics are implemented, the linear and the equal percentage.

In the case of linear characteristics, equal k_v value changes dk_v are assigned to equal stroke changes ds .

$$(dk_v = n_{lin} \cdot ds).$$

In the case of an equal percentage characteristic, an equal percentage change of the k_v value corresponds to a stroke change ds .

$$(dk_v/k_v = n_{eq\%prct} \cdot ds).$$

The operating characteristic $Q = f(s)$ specifies the correlation between the volumetric flow Q in the installed valve and the stroke s . This characteristic has the properties of the pipelines, pumps and consumers. It therefore exhibits a form which differs from the flow characteristic.

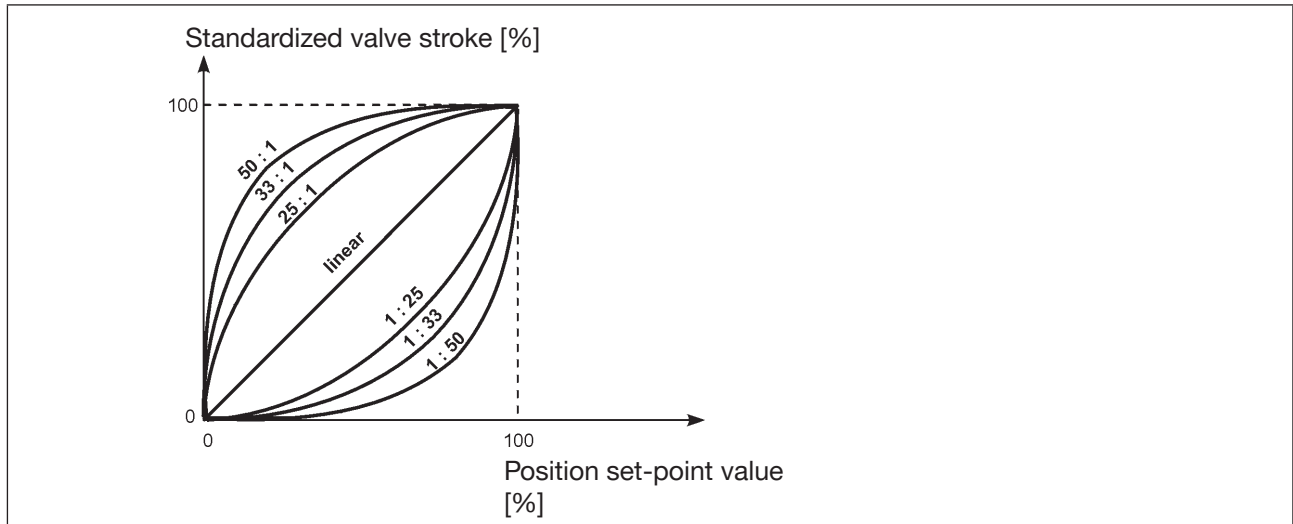

Figure 55: Characteristic

In the case of control tasks for closed-loop control systems it is usually particular demands which are placed on the course of the operating characteristic, e.g. linearity. For this reason it is occasionally necessary to correct the course of the operating characteristic in a suitable way. For this purpose the positioner features a transfer element which implements different characteristics. These are used to correct the operating characteristic.

Equal percentage characteristics 1:25, 1:33, 1:50, 25:1, 33:1, and 50:1 as well as a linear characteristic can be set. A characteristic can be freely programmed using nodes.

Entering the freely programmable characteristic

The characteristic is defined by 21 nodes distributed uniformly over the position set-point values ranging from 0 – 100%. They are spaced at intervals of 5%. A freely selectable stroke (adjustment range 0 – 100%) is assigned to each node. The difference between the stroke values of two adjacent nodes must not be greater than 20%.

Example of a programmed characteristic

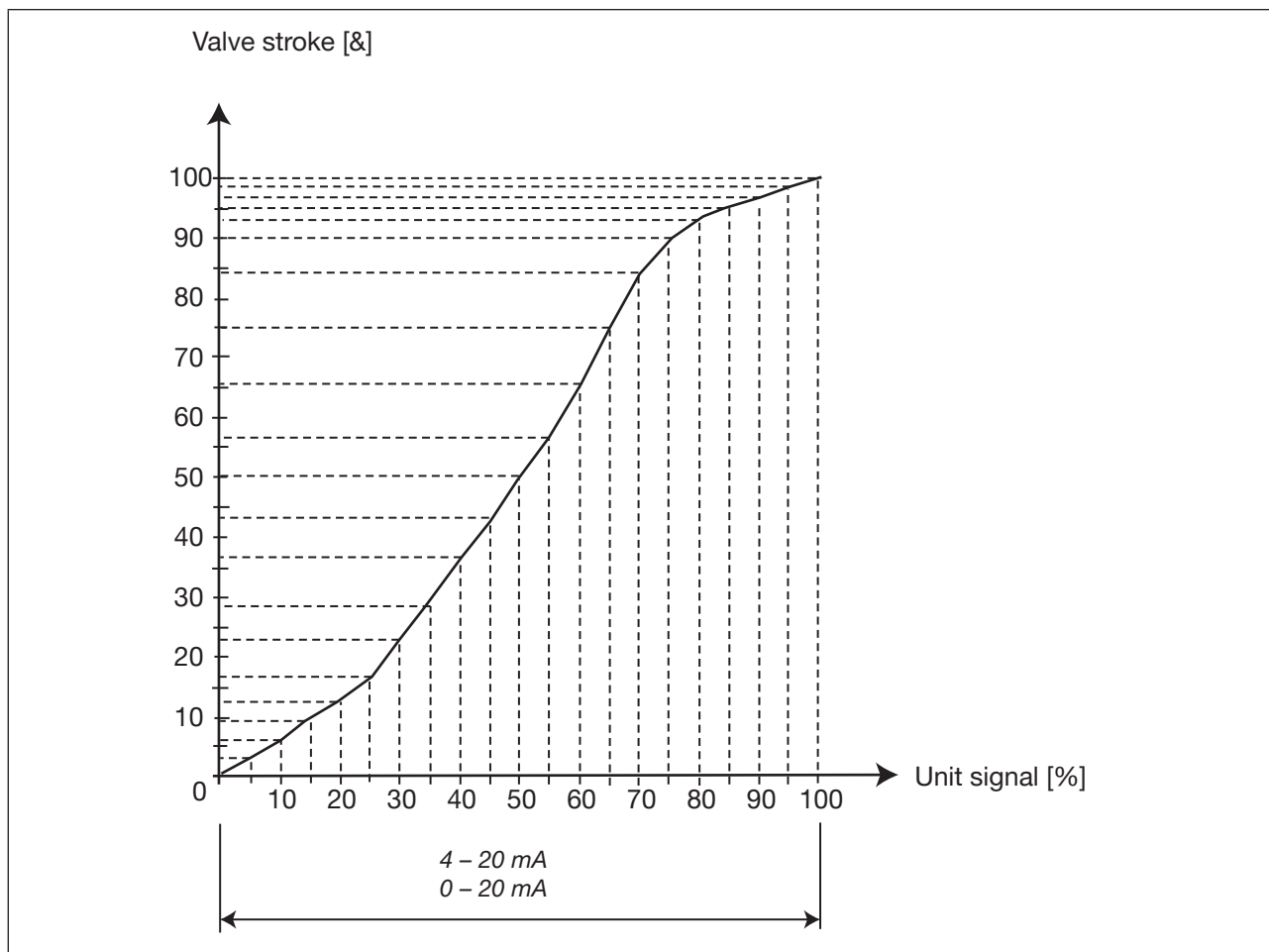

Figure 56: Example of a programmed characteristic

18.1.4 INPUT - Enter the standard signal

Under this menu option, enter the unit signal used for the set-point value.

Factory setting: 4 – 20 mA, 4-wire

- Further settings: 4 – 20 mA, 3-wire
- 0 – 20 mA, 4-wire
- 0 – 20 mA, 3-wire

18.1.5 **RESET -** **Reset to factory settings**

This function can be used to reset the positioner to the factory settings.

18.1.6 **X.TUNE -** **Automatic calibration of the position controller**



The *X.TUNE* function must be run for a function check of the positioner to adjust to specific local features.



WARNING

While the *X.TUNE* function is running, the valve automatically moves from its current position.

- ▶ Never run *X.TUNE* while a process is running.
- ▶ Take appropriate measures to prevent the system / positioner from being unintentionally actuated.

NOTE

Avoid maladjustment of the controller due to an incorrect compressed air supply or applied operating medium pressure.

- ▶ Run *X.TUNE* **whenever** the compressed air supply (= pneumatic auxiliary energy) is available during subsequent operation.
- ▶ Run the *X.TUNE* function preferably **without** operating medium pressure to exclude interference caused by flow forces.



To run *X.TUNE*, the positioner must be in the AUTOMATIC operating state (DIP switch 4 = OFF).

→ Select **Automatic calibration of the position controller**.

→ Start *X.TUNE*. To do this, click **Next**.

The progress of *X.TUNE* is shown in the communication software:

When the automatic adjustment completes, a message appears.

The changes are automatically transferred to the positioner's memory (EEPROM) after the *X.TUNE* function is successful.

18.2 Auxiliary functions

The following additional functions can be configured and parameterized via the communications software:

Function	Description
Reversal of the effective direction of the actuator <i>DIR.ACT</i>	Assignment of the aeration status of the actuator chamber to the actual position
Signal split range <i>SPLTRNG</i>	Signal split range; input signal as a % for which the valve runs through the entire stroke range.
Stroke limit <i>X.LIMIT</i>	Limit the mechanical stroke range
Limit actuating time <i>X.TIME</i>	Limit the control speed
Control parameters <i>X.CONTROL</i>	Parameterize the position controller
Safety position <i>SAFEPOS</i>	Input the safety position
Cable break detection ³¹⁾ <i>SIG.ERROR</i>	Configuration of signal level fault detection
Digital input ³¹⁾ <i>BINARY.IN</i>	Activation of the digital input
Analog output ³¹⁾ <i>OUTPUT</i>	Configuration of the outputs (only with auxiliary board for analogue feedback signal or digital outputs)

Table 41: Auxiliary functions

³¹⁾ Only for variant without fieldbus communication.

18.2.1 *DIR.ACT* - Reversal of the effective direction of the actuator

Use this function to set the effective direction between the aeration state of the actuator and the actual position.

Factory setting: Off (rise)

Rise: Direct effective direction (deaerated → 0 %; aerated 100 %)

Case: Inverse effective direction (deaerated → 100 %; aerated 0 %)

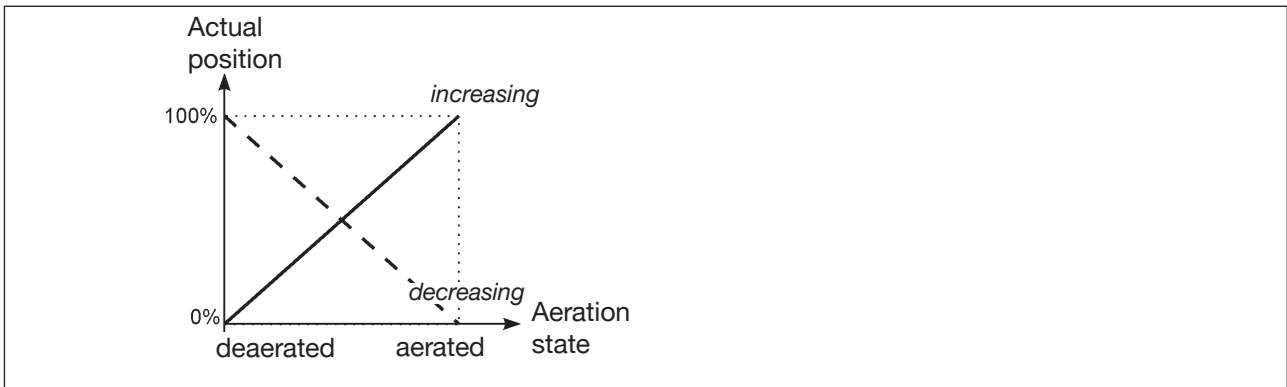

Figure 57: *DIR.ACT* graph

18.2.2 *SPLTRNG* - Signal split range

Minimum and maximum values of the input signal as a % for which the valve runs through the entire stroke range.

Factory setting: Lower signal range split = 0 %; Upper signal range split = 100 %

Lower value split range: Input the minimum value of the input signal as a %
Adjustment range: 0 – 75 %

Upper value split range: Input the maximum value of the input signal as a %
Adjustment range: 25 – 100 %

Use this function to limit the position set-point value range of the positioner by specifying a minimum and a maximum value. This makes it possible to divide a unit signal range that is used (4 – 20 mA, 0 – 20 mA) into several positioners (without or with overlapping). This allows several valves to be used alternately or, in the case of overlapping set-point value ranges, simultaneously as actuators.

To split a unit signal range into two set-point value ranges:

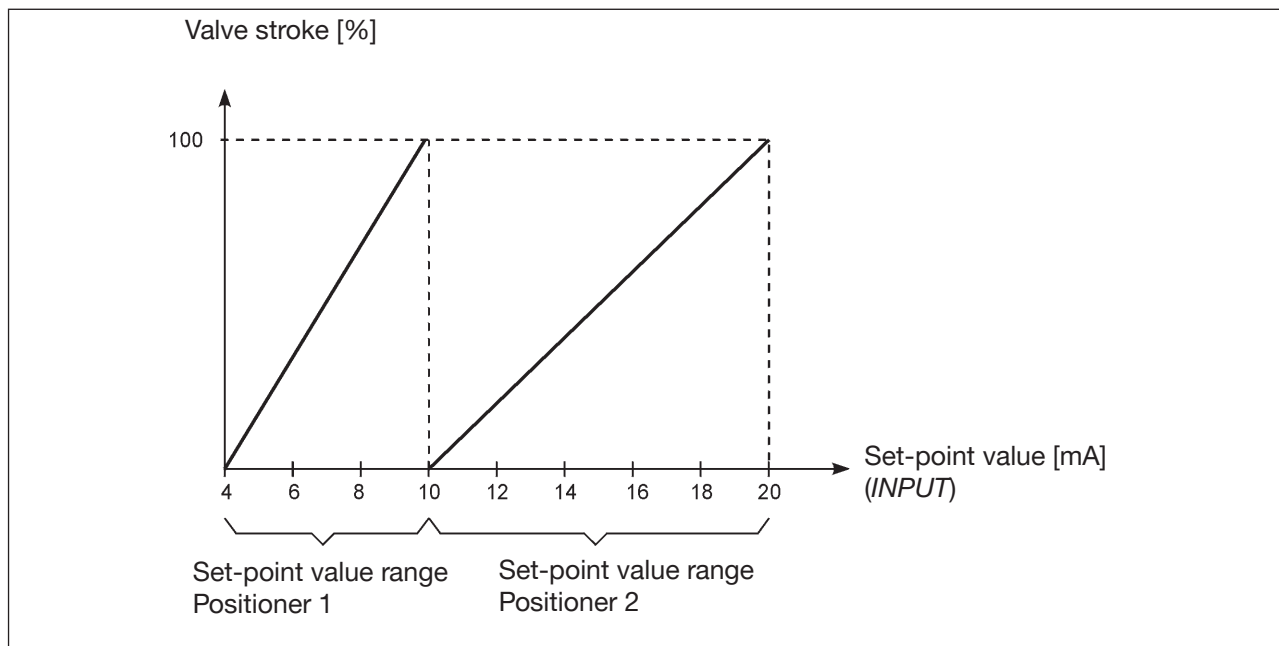

Figure 58: *SPLTRNG* graph

18.2.3 X.LIMIT - Stroke limit

This function limits the (physical) stroke to specified % values (lower and upper). In doing so, the stroke range of the limited stroke is set equal to 100 %. If the limited stroke range is left during operation, negative actual positions or actual positions greater than 100 % are shown.

Factory setting: Lower position limit = 0 %, upper position limit = 100 %

Adjustment ranges:

Stroke limit minimum: 0 – 50 % of the entire stroke

Stroke limit maximum: 50 – 100 % of the entire stroke

The minimum distance between the upper and lower stroke limit is 50 %. Therefore if one value is entered with a minimum distance of < 50 % the other value is adjusted automatically.

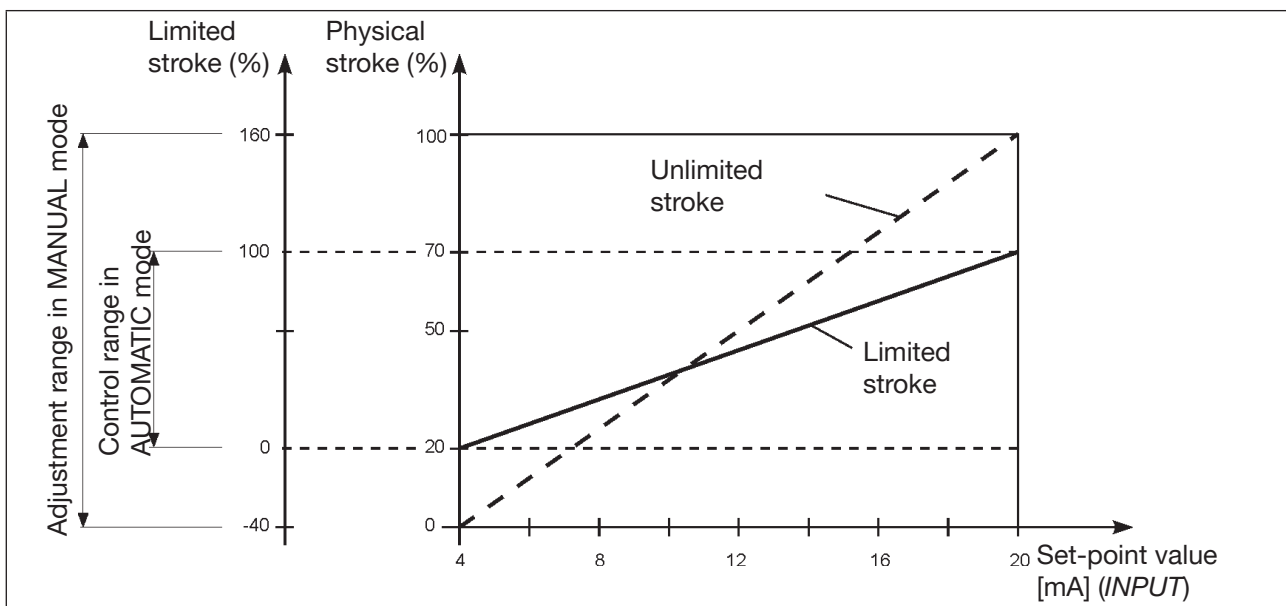

Figure 59: X.LIMIT graph

18.2.4 X.TIME - Limit actuating time

Use this function to specify the opening and closing times for the entire stroke and thereby limit control speeds.



When the *X.TIME* function is running, the minimum opening and closing time for the entire stroke is automatically entered for Open and Close. Therefore, movement can be at maximum speed.

Factory setting: values determined at the factory by the *X.TIME* function

If the control speed will be limited, values can be input for Open and Close which are between the minimum values determined by the *X.TIME* and 60 seconds.

Opening time: Opening time for entire stroke (in seconds)
Adjustment range: 1 – 60 seconds

Closing time: Closing time for entire stroke (in seconds)
Adjustment range: 1 – 60 seconds

Effect of limiting the opening speed when there is a jump in the set-point value

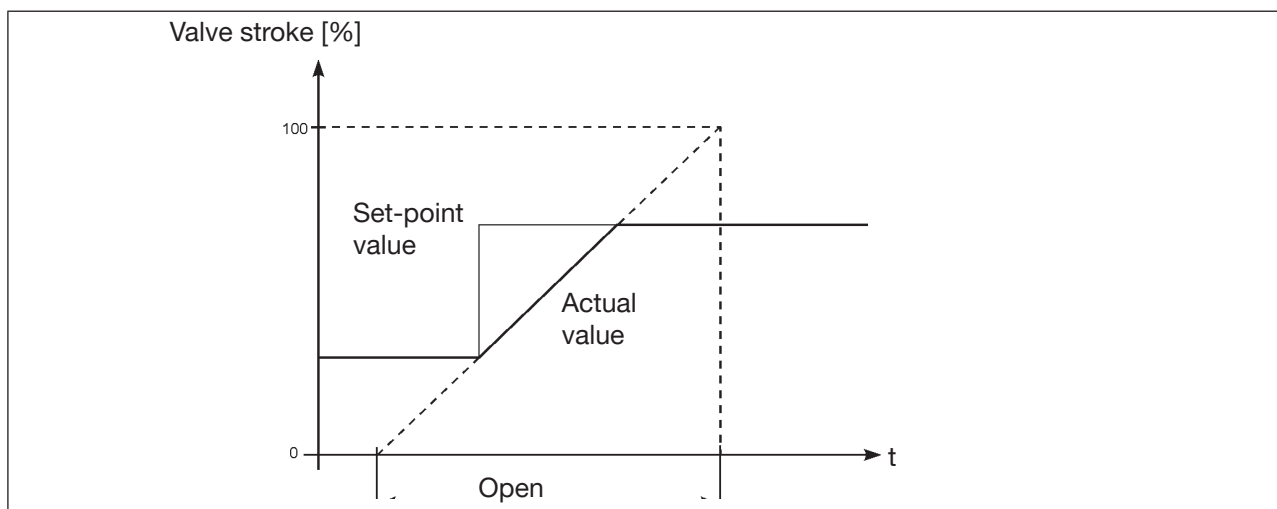

Figure 60: X.TIME graph

18.2.5 X.CONTROL - Control parameters of the positioner

Use this function to set the parameters for the positioner (dead band and amplification factors (kp)).

Deadband: Insensitivity range of the positioner

Entry for the deadband as a % in reference to the scaled stroke range;
i.e. stroke limit maximum - stroke limit minimum (see auxiliary function stroke limit (X.LIMIT)).

This function causes the controller to respond only beginning at a specific control difference. This function saves wear on the solenoid valves in the positioner and the pneumatic actuator.

! If the auxiliary function control parameters (X.CONTROL) is in the main menu while X.TUNE (Autotune of the positioner) is running, the deadband is determined automatically depending on the friction behavior of the actuator. The value determined in this way is an approximate value. You can re-adjust it manually.

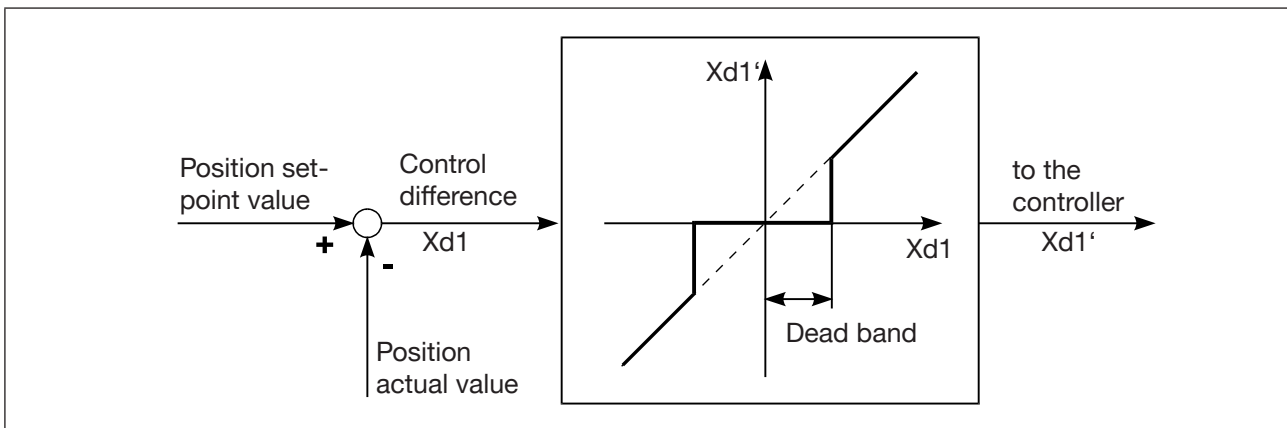

Figure 61: X.CONTROL graph

Open/close amplification factor: Parameters for the positioner

Open amplification factor: Amplification factor of the positioner (for closing the valve)

Close amplification factor: Amplification factor of the positioner (for opening the valve)

18.2.6 SAFPOS - Definition of the safe position

This function specifies the actuator safety position which is approached at defined signals.

! The set safety position is only approached if there is a corresponding signal at the digital input (for configuration see digital input (BINARY.IN)) or if a error occurs.
If the mechanical stroke range is limited with the stroke limit function (X.LIMIT), only safety positions within these limits can be approached.
This function is executed in AUTOMATIC mode only.

18.2.7 **SIG.ERROR** - Configuration of cable break detection (only for variant without fieldbus communication)

The cable break detection function (*SIG.ERROR*) is used to detect a fault on the input signal.



Cable break detection can be selected for a 4 – 20 mA signal only:
Fault if input signal ≤ 3.5 mA (± 0.5 % of final value, hysteresis 0.5 % of final value)

If 0 – 20 mA is selected, cable break detection cannot be selected.

A signal error is indicated on the device by the LED 1 for activated cable break detection (error or out of specification).

Safety position for activated cable break detection:

Active safe position function (*SAFEPOS*)

If a fault is detected, the actuator moves to the position set under safe position function.

Inactive safe position function (*SAFEPOS*)

If a fault is detected, the actuator moves to the end position which it would assume in the isolated state.

18.2.8 **BINARY.IN** (variant) - Configuration of the digital input (only for variant without fieldbus communication)

The following settings can be implemented:

- Approach the safety position
- Starting the function *X.TUNE*

Safety position

Digital input = 1 → Approach the safety position.

Active safety position function (*SAFEPOS*)

The actuator moves to the position set under safe position function.

Inactive safety position function (*SAFEPOS*)

The actuator moves to the end position which it would assume in the isolated state.

Starting the function *X.TUNE*

Digital input = 1 → Starting *X.TUNE*.

18.2.9 OUTPUT (variant) - Configuration of the analog output (only for variant without fieldbus communication)

The function analog output (OUTPUT) only appears in the selection of functions if the positioner has an analog output (variant) or if no parameters have been read in yet.

The analog output can be used for feedback of the current position or of the set-point value to the control center.

Function	Position (POS) Set-point value (CMD)	Output of the current position Output of the set-point value
Standard signal	4 – 20 mA 0 – 20 mA	Selection of the standard signal

18.2.10 Setting the LED mode, device status

User level: installer

Factory setting: valve mode + warnings

Menu or function	Values or description
Device	
> General settings	
> Parameter	
> Status LED	
Mode	<input checked="" type="radio"/> NAMUR mode <input type="radio"/> Valve mode <input type="radio"/> Valve mode + Warnings <input type="radio"/> Fixed color <input type="radio"/> LED off

Setting the LED mode, device status:

→ Status LED

→ Mode

Possible selection:

- NAMUR mode
- Valve mode
- Valve mode + Warnings
- Fixed color
- LED off

→ Select mode.

The mode is set.

19 SAFETY END POSITIONS

19.1 Safety end positions after failure of the electrical or pneumatic auxiliary power

Actuator system	Designation	Safety end positions after failure of the auxiliary power	
		electrical	pneumatic
	single-acting Control function A	down	pilot valve system with high air flow rate: down pilot valve system with low air flow rate: not defined
	single-acting Control function B	up	pilot valve system with high air flow rate: up pilot valve system with low air flow rate: not defined

Table 42: Safety end positions

20 MAINTENANCE

20.1 Safety instructions



DANGER

Risk of injury from high pressure in the equipment/device.

- ▶ Before working on equipment or device, switch off the pressure and deaerate/drain lines.

Risk of electric shock.

- ▶ Before working on equipment or device, switch off the power supply and secure to prevent reactivation.
- ▶ Observe applicable accident prevention and safety regulations for electrical equipment.



WARNING

Risk of injury from improper maintenance.

- ▶ Maintenance may be performed by authorised technicians only.

Risk of injury from unintentional activation of the system and an uncontrolled restart.

- ▶ Secure system from unintentional activation.
- ▶ Following maintenance, ensure a controlled restart.

20.2 Service at the air intake filter

DANGER

Risk of injury from high pressure in the equipment/device.

- ▶ Before working on equipment or device, switch off the pressure and deaerate/drain lines.

To protect the internal solenoid valves and the actuator, the pilot air is filtered.

The direction of flow of the air intake filter in installed state is from the inside to the outside through the filter material.

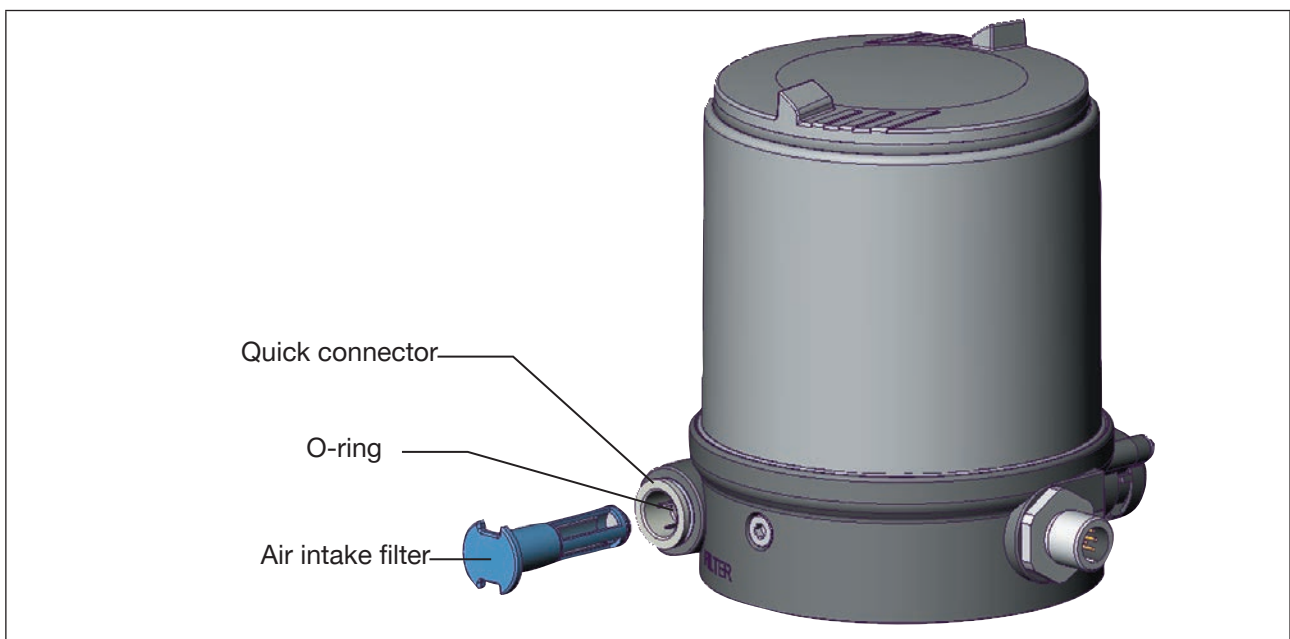

Figure 62: Service on the air intake filter

Procedure:

- Unlock the quick connector by pressing the holding element and pulling out the air intake filter (if necessary, use a suitable tool in between the recesses in the head of the filter).
- Clean the filter or, if necessary, replace the filter.
- Check inner O-ring and, if required, clean.
- Insert the air intake filter all the way into the quick connector.

DANGER

Risk of injury due to improper installation.

- ▶ Ensure that the air intake filter is installed correctly.

- Check that the air intake filter is secure.

21 ACCESSORIES

Designation	Order no.
Wrench for opening/closing the transparent cap	674077
Communication software Bürkert Communicator	Information at www.burkert.com

USB-büS interface set:	
USB-büS interface set 2 (büS stick + 0.7 m cable with M12 plug)	772551
büS adapter for büS service interface (M12 on büS service interface Micro-USB)	774931
büS cable extension (M12 pin to M12 socket), length 1 m	772404
büS cable extension (M12 pin to M12 socket), length 3 m	772405
büS cable extension (M12 pin to M12 socket), length 5 m	772406
büS cable extension (M12 pin to M12 socket), length 10 m	772407

Table 43: Accessories

21.1 Communications software

The PC operating program “Communicator” is designed for communication with the devices from the Bürkert positioner family (valid since serial number 20000).



A detailed description and precise schedule of the procedure for the installation and operation of the software can be found in the associated documentation.

Download the software at: www.burkert.com

22 DISASSEMBLY

22.1 Safety instructions



DANGER

Risk of injury from high pressure in the equipment/device.

- ▶ Before working on equipment or device, switch off the pressure and deaerate/drain lines.

Risk of electric shock.

- ▶ Before working on equipment or device, switch off the power supply and secure to prevent reactivation.
- ▶ Observe applicable accident prevention and safety regulations for electrical equipment.



WARNING

Risk of injury from improper disassembly.

- ▶ Disassembly may be carried out by authorized technicians only and with the appropriate tools.

Risk of injury from unintentional activation of the system and an uncontrolled restart.

- ▶ Secure system from unintentional activation.
- ▶ Following disassembly, ensure a controlled restart.

22.2 Disassembly the positioner

Procedure:

1. Pneumatic connection



DANGER

Risk of injury from high pressure in the equipment/device.

- ▶ Before working on equipment or device, switch off the pressure and deaerate/drain lines.

→ Loosen the pneumatic connection.

→ Series 20xx:

Loosen the pneumatic connection between positioner and actuator.

2. Electrical connection



DANGER

Risk of electric shock.

- ▶ Before working on equipment or device, switch off the power supply and secure to prevent reactivation.
- ▶ Observe applicable accident prevention and safety regulations for electrical equipment.

Circular plug-in connector:

→ Loosen the circular plug-in connector.

Cable gland:

→ Open the positioner: unscrewing the body casing in an anticlockwise direction.

→ Unscrew the screw terminals and pull out cables.

→ Close the positioner.

3. Mechanical connection

→ Loosen the fastening screws.

→ Remove the positioner upwards.

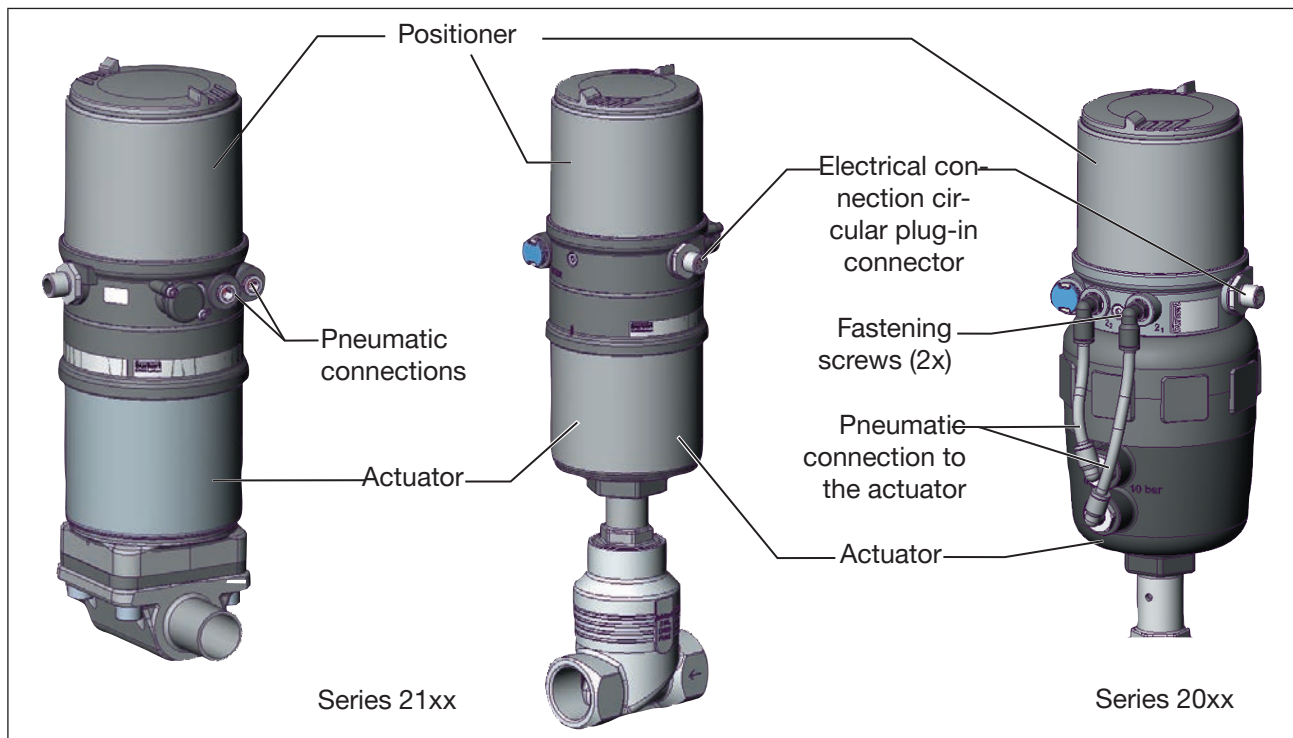

Figure 63: Disassembly the positioner

23 TRANSPORTATION, STORAGE, DISPOSAL

NOTE

Damage in transit due to inadequately protected devices.

- ▶ Protect the device against moisture and dirt in shock-resistant packaging during transportation.
- ▶ Observe permitted storage temperature.

NOTE

Incorrect storage may damage the device.

- ▶ Store the device in a dry and dust-free location.
- ▶ Storage temperature: -20 to +65 °C

Environmentally friendly disposal



- ▶ Follow national regulations regarding disposal and the environment.
- ▶ Collect electrical and electronic devices separately and dispose of them as special waste.

Further information at country.burkert.com

