

BVS 16 ATEX E 118 X / IECEx BVS 16.0091 X FM25CA0107X / FM25US0304X Types 8791, 8792, 8793

Position controller and process controller with approval
II 3G / II 3D / CL I, II, III Div 2 / CL I, ZN2 / ZN 22

Stellungsregler und Prozessregler mit Zulassung
II 3G / II 3D / CL I, II, III Div 2 / CL I, ZN2 / ZN 22

Régulateur de position et régulateur de process avec homologation
II 3G / II 3D / CL I, II, III Div 2 / CL I, ZN2 / ZN 22

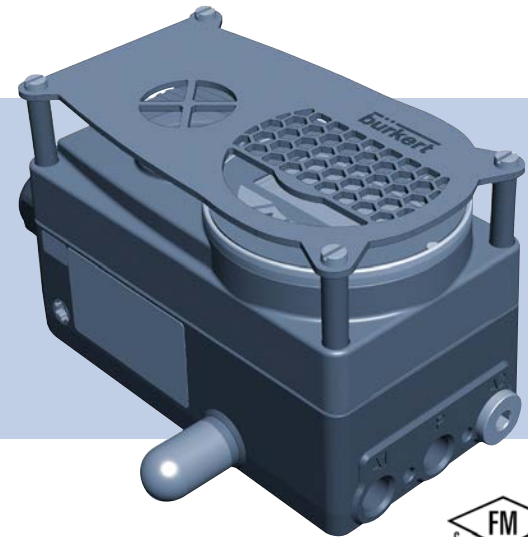

Operating Instructions

Bedienungsanleitung
Manuel d'utilisation



We reserve the right to make technical changes without notice.
Technische Änderungen vorbehalten.
Sous réserve de modifications techniques.

© Bürkert Werke GmbH & Co. KG, 2010-2026

Operating Instructions 2603/05_EU-ml_00809480 / Original DE

1	ADDITIONAL INSTRUCTIONS	4
1.1	Definitions of terms	4
2	SYMBOLS	4
3	AUTHORIZED USE	5
4	PARTICULAR SAFETY INSTRUCTIONS	5
4.1	Special conditions of use	6
5	INSTRUCTIONS ON OPERATION IN THE POTENTIALLY EXPLOSIVE ATMOSPHERE	7
5.1	Media in the potentially explosive atmosphere	7
5.2	Actuators/valves in the potentially explosive atmosphere	7
5.3	Cleaning in the potentially explosive atmosphere	7
5.4	Adhesive labels for the potentially explosive atmosphere	7
5.5	Ambient temperature in the potentially explosive atmosphere	9
5.6	Grounding the housing	9
5.7	Installing sheet metal cover and housing cover	9
5.8	Explosion protection approval.....	10

1 ADDITIONAL INSTRUCTIONS

The additional instructions contain safety instructions and information for the use of the device in the potentially explosive atmosphere.

Keep these instructions in a location which is easily accessible to every user and make these instructions available to every new owner of the device.

Important safety information.

Read these instructions carefully and thoroughly. Study in particular the chapters entitled *Particular safety instructions* and *Authorized use*.

- ▶ The additional instructions must be read and understood.

Further information on the device can be found in the operating instructions of the corresponding device.

 The operating instructions can be found on the Internet at: www.burkert.com

1.1 Definitions of terms

The term "device" used in these instructions always stands for the position controllers Type 8791 and Type 8792 and for the process controller Type 8793.

2 SYMBOLS

The following symbols are used in these instructions.



DANGER!

Warns of an immediate danger.

- ▶ Failure to observe the warning will result in a fatal or serious injury.



WARNING!

Warns of a potentially dangerous situation.

- ▶ Failure to observe the warning may result in a serious or fatal injury.



CAUTION!

Warns of a possible danger.

- ▶ Failure to observe this warning may result in a moderate or minor injury.

NOTE!

Warns of damage to property.



Important tips and recommendations.



Refers to information in these operating instructions or in other documentation.

- ▶ designates instructions for risk prevention.

→ designates a procedure which you must carry out.

3 AUTHORIZED USE

Non-authorized use of the device may be dangerous to people, nearby equipment and the environment.

- ▶ The device is designed to be mounted on pneumatic lifting and rotary actuators for the control and regulation of media. Type 8791 to 8793 PX45, PR09 is approved according to device group II category 3G/D for use in explosion-risk areas of Zones 2 and 22. The complete identification is located on the type label (see information listed on the label for the approval).
- ▶ The device is mounted on a pneumatic lifting or rotary actuator. In doing so, the control valve must have at least explosion protection approval of the position/process controller.
- ▶ During use observe the permitted data, the operating conditions and conditions of use specified in the contract documents, the operating instructions and on the type label
 - of the position/process controller and
 - the control valve.
- ▶ Use the device only in conjunction with third-party devices and components recommended and authorized by Bürkert.
- ▶ Correct transportation, storage and installation as well as careful operation and maintenance are essential for reliable and fault-free operation.
- ▶ Use the device only for its intended purpose.

4 PARTICULAR SAFETY INSTRUCTIONS



DANGER!

Risk of explosion when removing the electric circular plug.

- ▶ Secure cable connections, which use circular plugs, with suitable locking clips. This will prevent the circular plug from working loose.
For example: EXCLIP, FA. Phoenix Contact, Type SAC-M12-EXCLIP-M, art. no. 1558988 or Type SAC-M12-EXCLIP-F, art. no. 1558991 or locking clips, FA. ESCHA
Locking clip M8 x 1, art. no. 8040691
Locking clip M12 x 1, art. no. 8040501.
- ▶ Do not remove or connect electric circular plug until the power supply has been disconnected.

Risk of explosion when opening the device.

- ▶ Open device only when no explosive atmosphere is present.

Risk of explosion caused by electrostatic discharge.

In the event of a sudden discharge from electrostatically charged devices or individuals, there is a risk of explosion in the potentially explosive atmosphere.

- ▶ Protect device from large charge-generating processes.
- ▶ Ground housing before start-up.
- ▶ Take suitable measures to ensure that no electrostatic discharges can build up in the potentially explosive atmosphere.
- ▶ Clean the device surface by gently wiping it with a damp or anti-static cloth only.



DANGER!

To prevent the risk of explosion, observe not only the safety instructions in the operating instructions for operation in the potentially explosive atmosphere, but also the following:

- ▶ Specifications on the type label concerning temperature class, ambient temperature, degree of protection and voltage.
- ▶ Do not use device in areas where there is gas or dust with a lower ignition temperature than indicated on the type label.
- ▶ Installation, operation and maintenance may be performed by qualified technicians only.
- ▶ Observe the applicable safety regulations (also national safety regulations) as well as the general rules of technology for construction and operation.
- ▶ Do not repair the device yourself, but replace it with an equivalent device. Repairs may be performed by the manufacturer only.
- ▶ Do not expose the device to any mechanical and/or thermal loads which will exceed the limits described in the operating instructions.
- ▶ Use only cable and line entry points which have been approved for the respective application area and which have been screwed into place according to the associated installation instructions.
- ▶ The cable glands may be used for the insertion of permanently installed cables and lines only.
- ▶ Close all unnecessary cable glands with lock screws approved for the potentially explosive atmosphere.

- ▶ Use pre-assembled cable glands according to the installation instructions supplied by the gland manufacturer. Before start-up in the potentially explosive atmosphere, check whether the cable gland, as described in the associated installation instructions, has been installed.

4.1 Special conditions of use

- ▶ Do not use the device in dust atmospheres in which intensive charging processes can be expected.
- ▶ Use the device only in an area with at least degree of soiling 2, as defined in IEC 60994-1.
- ▶ Ensure that the transient protection has been set to a value which does not exceed 140 % of the measured peak voltage value at the supply connections of the device.
- ▶ If devices feature a circular plug connection (multipole), the mating plug will be provided by the end user and is not an object of the approval. The mating plug must satisfy the relevant requirements of the IEC 60079-0, IEC 60079-7 and IEC 60079-31 and must have at least housing degree of protection IP65 according to IEC 60529.
- ▶ If devices feature a circular plug connection (multipole), use a special locking clip which prevents the plug from being loosened without a tool.

5 INSTRUCTIONS ON OPERATION IN THE POTENTIALLY EXPLOSIVE ATMOSPHERE

When using the device in an potentially explosive atmosphere, observe the following:

5.1 Media in the potentially explosive atmosphere

! If explosive media are used, this can result in additional explosion risks.

5.2 Actuators/valves in the potentially explosive atmosphere

! Use in an explosive atmosphere may be restricted by the actuators/valves. Observe the operating instructions of the actuators/valves.

5.3 Cleaning in the potentially explosive atmosphere

! DANGER!

Risk of explosion caused by electrostatic charge.

- ▶ Clean the device surface by gently wiping it with a damp or anti-static cloth only.

! Check that cleaning agents are approved for use in explosive atmospheres.

5.4 Adhesive labels for the potentially explosive atmosphere

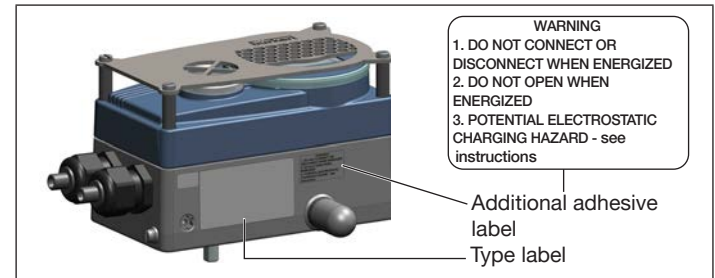

Fig. 1: Arrangement of the adhesive labels for the potentially explosive atmosphere, additional adhesive label

BVS 16 ATEX E 118 X

Instructions on operation in the potentially explosive atmosphere

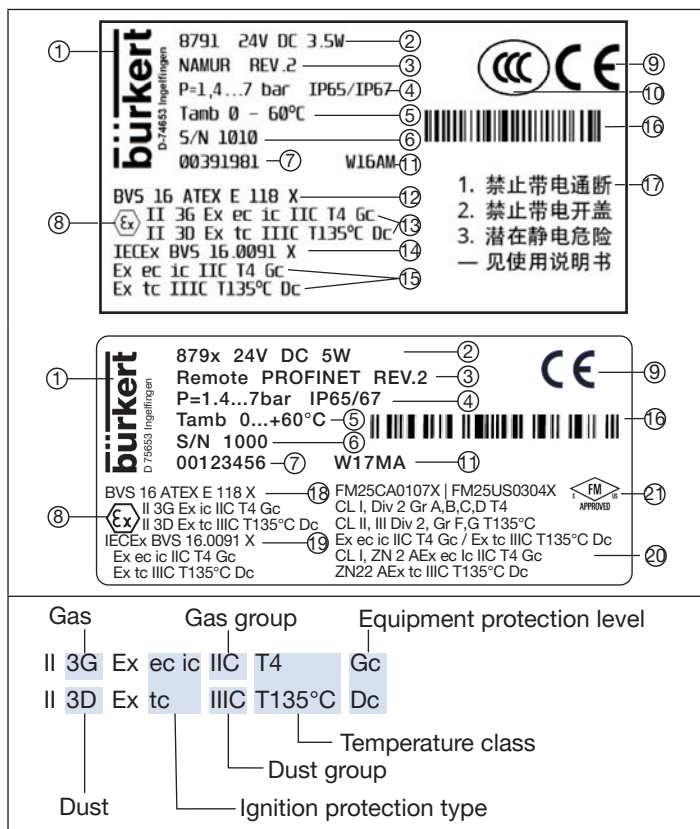

Fig. 2: Type label (example) of a device with ATEX approval

Item	Description
1	Manufacturer's logo
2	Type identification, nominal voltage, nominal power
3	Device design (NAMUR/Remote; 24V DC/Profibus DP/DeviceNet)
4	Nominal range of supply pressure and degree of protection
5	Ambient temperature range
6	Serial number
7	Order number
8	Ex Logo
9	CE marking
10	Other approval logos
11	Manufacture code
12	ATEX, certificate author and certificate number
13	ATEX, identification of the explosion protection
14	IECEx, certificate author and certificate number
15	IECEx, identification of the explosion protection
16	Barcode (includes order number and serial number)
17	Warning
18	ATEX approval
19	IECEx approval
20	FM approval
21	FM logo

Tab. 1: Description of the type label data

5.5 Ambient temperature in the potentially explosive atmosphere

Types 8791, 8792, 8793 PX45 and PR09: 0...+60 °C

5.6 Grounding the housing



DANGER!

Risk of explosion caused by electrostatic discharges.

- ▶ Ground housing before starting up the device.

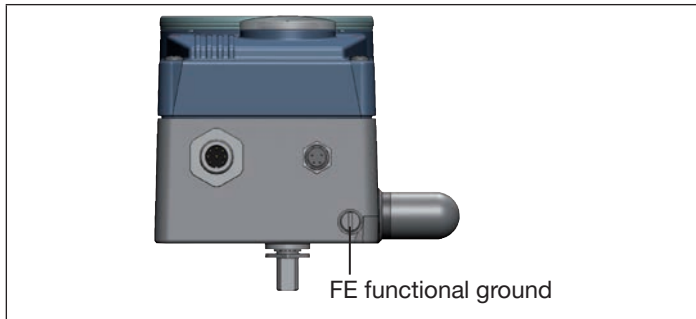

Fig. 3: Connection for grounding the housing

→ Use a suitable cable lug for grounding.

5.7 Installing sheet metal cover and housing cover



DANGER!

Risk of explosion when opening the device.

- ▶ Open device only when no explosive atmosphere is present.
- ▶ Install electrical system only when no explosive atmosphere is present.

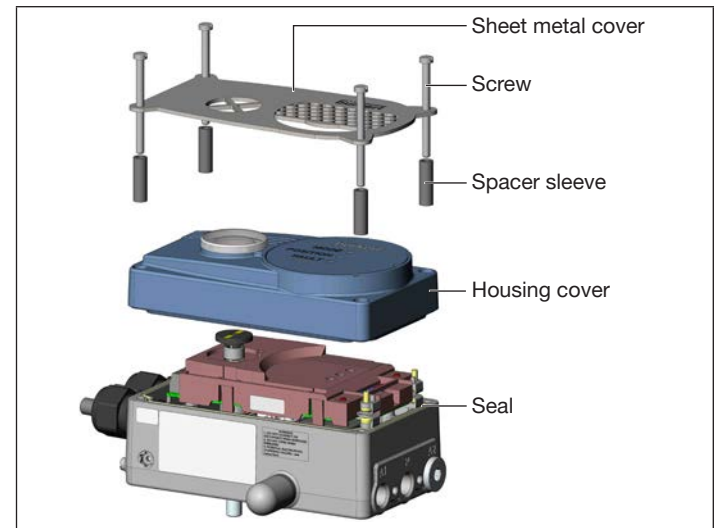

Fig. 4: Installing/removing sheet metal cover and housing cover using Type 8791 as an example

BVS 16 ATEX E 118 X

Instructions on operation in the potentially explosive atmosphere

To install the electrical system using screw-type terminals and to start up Type 8791 using DIP switches, remove the sheet metal cover and the housing cover:

- Unscrew screws (4 x) on the housing cover.
- Remove sheet metal cover together with the screws and spacer sleeves.
- Remove housing cover and fold to the side.
- Install or start up device.

After installing or starting up the device, mount sheet metal cover and housing cover:

- Close housing cover, ensuring that the seal is correctly fitted.
- Attach sheet metal cover with screws and spacer sleeves (see "Fig. 4").
- Tighten screws (4 x) hand-tight as far as the stop.

5.8 Explosion protection approval

The explosion protection approval is only valid if you use the modules and components authorized by Bürkert, as described in these operating instructions.

If you make unauthorized changes to the system, the modules or components, the explosion protection approval will be terminated.

This product is subject to review by the Shanghai Inspection and Testing Institute of Instruments and Automation Systems Co., Ltd. (SITIIAS), has been CCC certified to comply with requirements of national explosion-proof series standard (GB/T 3836.2021-Explosive Atmospheres).

For PX45:

The EU Type-Examination Certificate
BVS 16 ATEX E 118 X and
IECEX BVS 16.0091 X

was issued by
DEKRA EXAM GmbH
Dinnendahlstraße 9
D-44809 Bochum
Germany

Production is audited by the Fiditas (CE2829).

For PR09:

FM Approvals LLC. 1151 Boston-Providence
Turnpike, Norwood, MA 02062 USA

country.burkert.com