

Flow rate controller for gases

- Reliable and automated flow control on site
- Stable control of the set point, independent on pressure fluctuations
- Programmable alarm functions (pressure monitoring)
- Simple start-up by manual setpoint setting and display
- Leakage air compensation programmable for dense phase conveying systems

Product variants described in the data sheet may differ from the product presentation and description.

Can be combined with

	Type 6281 Servo-assisted 2/2-way diaphragm valve	▶
	Type 2100 Pneumatically operated 2/2-way angle seat valve ELEMENT for decentralized automation	▶
	Type 8805 Ball valve / Butterfly valve with pneumatic rotary actuator	▶
	Type 8653 AirLINE Field – the valve island – optimised for process automation	▶
	Type 8746 Mass flow controller (MFC)/ mass flow meter (MFM) for gases	▶

Type description

The flow rate controller Type 8750 represents a closed flow control loop to measure and control gases using the differential pressure principle. The reliable and robust system consists of an ELEMENT control valve, type 2301, the compact process controller type 8693 put on top of the valve and two pressure transmitters, type 8325. The Bürkert flow rate controller does not need a separate flow meter. The valve seat serves as variable orifice. From the pressure difference across the valve and the given density and temperature a volume flow, referring to the conditions programmed, can be calculated. For that the process controller uses the flow characteristics of the valve and the scales of the pressure transmitters programmed. The volume flow set can then be adjusted by changing the stroke of the control valve. The flow rate controller offers a high repeatability and large measuring range. Beneficial is that the control itself is used for both, controlling the flow and measuring over an orifice. With the variable orifice of the control valve the measurement range is increased significantly. Low assembly costs and easy commissioning are further advantages of this unique product.

DTS 1000089368 EN Version: T Status: RL (released | freigegeben | valide) printed: 22.01.2026

Table of contents

1. General technical data	3
<hr/>	
2. Approvals and conformities	4
2.1. General notes	4
2.2. Conformity	4
2.3. Standards	4
2.4. Foods and beverages/Hygiene	4
<hr/>	
3. Materials	4
3.1. Bürkert resistApp	4
3.2. Material specifications	5
ELEMENT variant, actuator M (70 mm), N (90 mm), P (130 mm)	5
CLASSIC variant, actuator L (225 mm)	5
Standard pressure transmitter Type 8325	5
<hr/>	
4. Dimensions	6
4.1. Overall device	6
4.2. Connection flange	7
<hr/>	
5. Performance specifications	8
5.1. Fluidic data	8
Flow characteristics	8
Overview of fluidic data for flow under seat	8
<hr/>	
6. Product operation	9
6.1. Flow measurement principle	9
<hr/>	
7. Product installation	9
7.1. Piping upstream of the fluid flow regulator	9
7.2. Electrical connections	10
Multipole connection	10
PROFIBUS DPV1	11
<hr/>	
8. Ordering information	11
8.1. Bürkert eShop	11
8.2. Recommendation regarding product selection	12
8.3. Bürkert product filter	12
8.4. Bürkert Product Enquiry Form	12
8.5. Ordering chart flange	12
8.6. Ordering chart accessories	13

DTS 1000089368 EN Version: T Status: RL (released | freigegeben | valide) printed: 22.01.2026

1. General technical data

Product properties	
Dimensions	Further information can be found in chapter “4. Dimensions” on page 6.
Material	Further information can be found in chapter “3.2. Material specifications” on page 5.
Design	Globe control valve with integrated flow measurement and control
Nominal diameter	DN 15...DN 100
Port connection	Flange according to DIN EN 1092 - 1, ANSI B 16.5 or JIS 10K
Safety setting in case of power failure	Normally closed
Flow direction	Against closing direction (below seat)
Performance data	
Operating pressure of the valve ¹⁾	0...16 bar
Nominal pressure	< PN 25 (DIN EN 1333), Class 150 (DIN EN 1759)
Pilot pressure	<ul style="list-style-type: none"> Actuator M, N, P: 5.5...7 bar (see “ELEMENT variant, actuator M (70 mm), N (90 mm), P (130 mm)” on page 5) Actuator L: 5...6 bar (see “CLASSIC variant, actuator L (225 mm)” on page 5) Optional on request: variant for reduced control pressure from 3.5 bar
Seat leakage	Leakage class VI for PTFE (soft sealing) according to DIN EN 60534 - 4
K _{vs} values	2.1 m ³ /h...140 m ³ /h, see “5.1. Fluidic data” on page 8
Operating characteristic	Equal percentage
Rangeability	≤ 50:1
Flow rate measurement	
Measured variable	Volume flow, reference conditions programmable
Measurement principle	Differential pressure via orifice plate and pressure transmitter on the inlet and outlet side of the orifice plate (see “6.1. Flow measurement principle” on page 9)
Pressure measurement range ²⁾	0...100 mbar to 0...16 bar
Pressure measurement principle	Piezoresistive
Pressure measuring error	≤ 0.5 % FS
Electrical data	
Operating voltage	24 V DC ± 10 %
Residual ripple	≤ 10 %
Electrical connection	
Operating voltage connection	1 x M12 circular plug-in connector, 4-pin
Analogue input signals/ Analogue output signals	1 x M12 circular plug-in connector, 8-pin (for set-point and actual value) Additionally for bus communication: 1 x M12 circular plug-in connector, 5-pin
Internal signals	1 x M8 circular plug-in connector, 4-pin (for connecting the pressure transmitters)
Medium data	
Operating medium	Air, nitrogen, carbon dioxide, neutral gases, fuel gases; oxygen (on request)
Medium temperature	- 10 °C...+ 100 °C
Control medium	Air or neutral gases according to DIN ISO 8573 - 1: <ul style="list-style-type: none"> Dust Cl. 7 (< 40 µm) Particle density Cl. 5 (< 10 mg/m³) Pressure dew point Cl. 3 (≤ - 20 °C) Oil concentration Cl. X (< 25 mg/m³)
Product connections	
Analogue interface	4...20 mA, 0...20 mA, 0...10 V or 0...5 V
Digital communication interface	PROFIBUS DPV1, Industrial Ethernet: EtherNet/IP, PROFINET
Pilot air ports	G 1/8, stainless steel
Approvals and conformities	
Certificate	Material certificate 2.2 or 3.1 (on request)
Degree of protection	IP65 / IP67 according to EN 60529
Foods and beverages/Hygiene	Further information can be found in chapter “2.4. Foods and beverages/Hygiene” on page 4.
Environment and installation	
Installation position	Horizontal or vertical
Ambient temperature	-10 °C...+ 55 °C

1.) The pressure measuring range of the pressure transmitters must be observed.

2.) The pressure range of the pressure sensor is selected according to the maximum working pressure of the application.

2. Approvals and conformities

2.1. General notes

- The approvals and conformities listed below must be stated when making enquiries. This is the only way to ensure that the product complies with all required specifications.
- Not all available variants can be supplied with the below mentioned approvals or conformities.

2.2. Conformity

In accordance with the Declaration of Conformity, the product is compliant with the EU Directives.

2.3. Standards

The applied standards which are used to demonstrate compliance with the EU Directives are listed in the EU-Type Examination Certificate and/or the EU Declaration of Conformity.

2.4. Foods and beverages/Hygiene

Conformity	Description
FDA	FDA – Code of Federal Regulations (valid for variable code PL02, PL03) All wetted materials are compliant with the Code of Federal Regulations published by the FDA (Food and Drug Administration, USA) according to the manufacturer's declaration.
	EC Regulation 1935/2004 of the European Parliament and of the Council (valid for variable code PL01, PL02) All wetted materials are compliant with EC Regulation 1935/2004/EC according to the manufacturer's declaration.

3. Materials

3.1. Bürkert resistApp

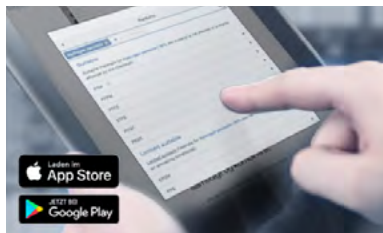

Bürkert resistApp – Chemical Resistance Chart

You want to ensure the reliability and durability of the materials in your individual application case? Verify your combination of media and materials on our website or in our resistApp.

[Start Chemical Resistance Check](#)

3.2. Material specifications

ELEMENT variant, actuator M (70 mm), N (90 mm), P (130 mm)

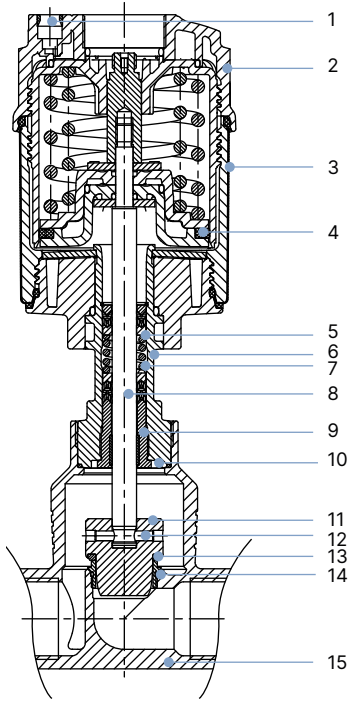

No.	Element	Material
1	Pilot air ports	Push-in connector, PP
2	Actuator	PPS
3	Cover	Stainless steel 1.4561
4	Piston seal	FKM
5	Spring	Stainless steel 1.4310
6	Pipe	Stainless steel CF3M
7	Spindle sealing	PTFE V-rings (filled), with spring compensation
8	Spindle	Stainless steel 1.4401/316 resp. 1.4404/316L
9	Spindle guide	Stainless steel 1.4404/316L, PTFE-filled
10	Body seal	Graphite or PTFE
11	Control cone	Stainless steel 1.4571
12	Spring pin	Stainless steel 1.4310
13	Seat seal	PTFE
14	Valve seat with O-ring	Stainless steel 1.4571, EPDM
15	Valve body	Stainless steel CF3M/316L
-	Pipe for inlet and outlet section ¹⁾	Stainless steel 1.4404/316L resp. 1.4435/316L
-	Pressure sensor sleeve ¹⁾	Stainless steel 1.4404/316L
-	Connection flange ¹⁾	Stainless steel 1.4404/316L

1.) Not shown in the drawing

CLASSIC variant, actuator L (225 mm)

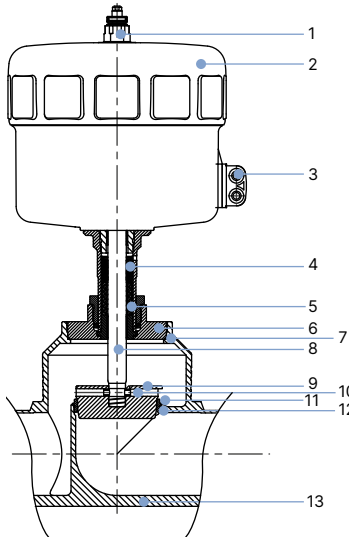

No.	Element	Material
1	Adapter	Stainless steel 1.4305
2	Actuator	Polyamide (PA)
3	Pilot air ports	Stainless steel 1.4305
4	Spindle sealing	PTFE V-rings (filled), with spring compensation
5	Spring	Stainless steel 1.4568
6	Nipple	Stainless steel 1.4404
7	Body seal	Graphite or PTFE
8	Spindle	Stainless steel 1.4404/316L
9	Control cone	Stainless steel 1.4571
10	Spring pin	Stainless steel 1.4310
11	Seat seal	PTFE
12	Valve seat with O-ring	Stainless steel 1.4571, EPDM
13	Valve body	Stainless steel CF3M/316L
-	Pipe for inlet and outlet section ¹⁾	Stainless steel 1.4404/316L resp. 1.4435/316L
-	Pressure sensor sleeve ¹⁾	Stainless steel 1.4404/316L
-	Connection flange ¹⁾	Stainless steel 1.4404/316L

1.) Not shown in the drawing

Standard pressure transmitter Type 8325

Description	Material
Non-wetted parts	
Body of standard variant	Stainless steel 1.4571/316Ti
Wetted parts	
Standard variant < 0.4 bar	Stainless steel 1.4571/316Ti
Standard variant ≥ 0.4 bar	Stainless steel 1.4404/316L (for ≤ 10 bar), stainless steel 1.4534/PH 13-8 Mo (for > 10 bar)
Flush diaphragm variant (standard)	Stainless steel 1.4571/316Ti, FKM seal

DTS 1000089368 EN Version: T Status: RL (released | freigegeben | valide) printed: 22.01.2026

4. Dimensions

4.1. Overall device

Note:

Dimensions in mm

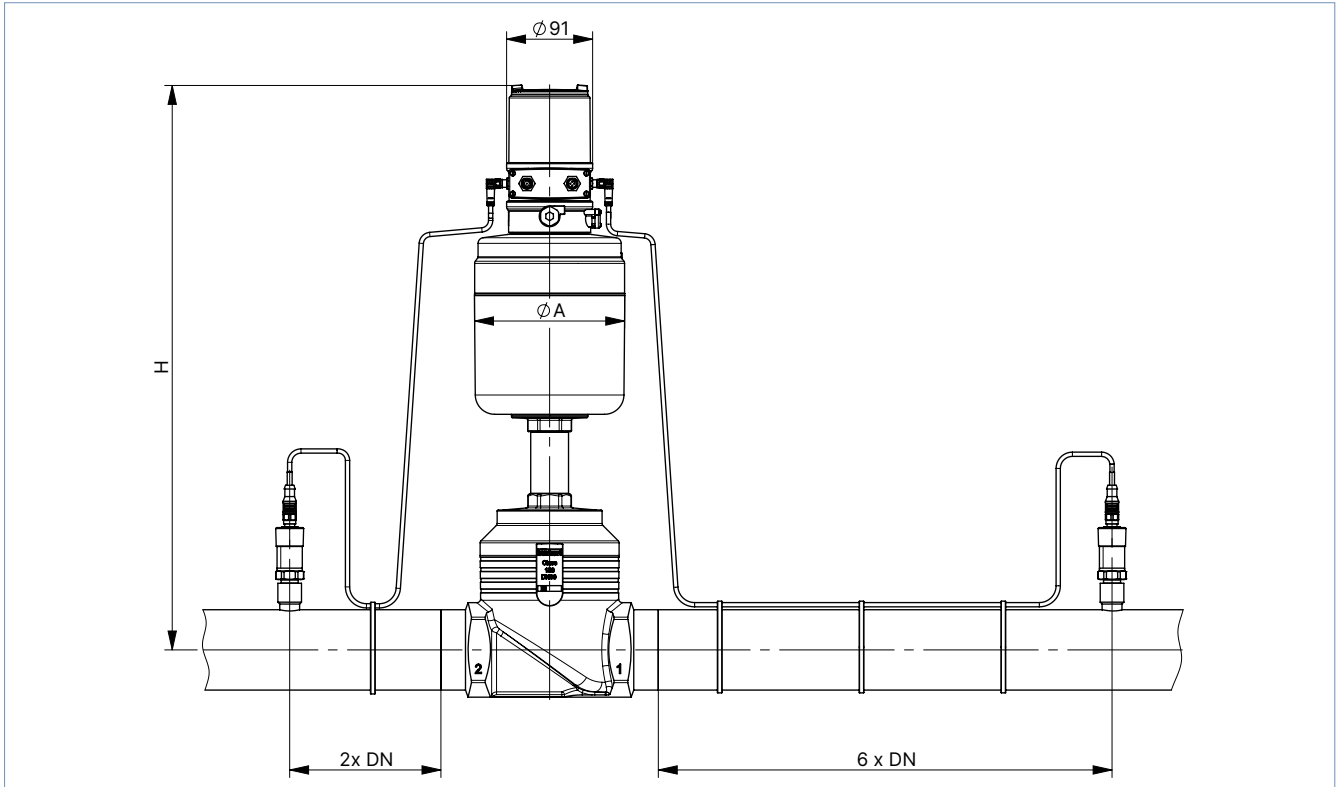

Nominal diameter DN	Actuator size	$\varnothing A$ [mm]	H [mm]
15	$\varnothing 70$ (M) ELEMENT	91	383
25	$\varnothing 70$ (M) ELEMENT	91	392
40	$\varnothing 90$ (N) ELEMENT	120	478
50	$\varnothing 130$ (P) ELEMENT	159	536
65	$\varnothing 130$ (P) ELEMENT	159	590
80	$\varnothing 130$ (P) ELEMENT	159	598
	$\varnothing 225$ (L) CLASSIC	261	640
100	$\varnothing 130$ (P) ELEMENT	159	608
	$\varnothing 225$ (L) CLASSIC	261	650

4.2. Connection flange

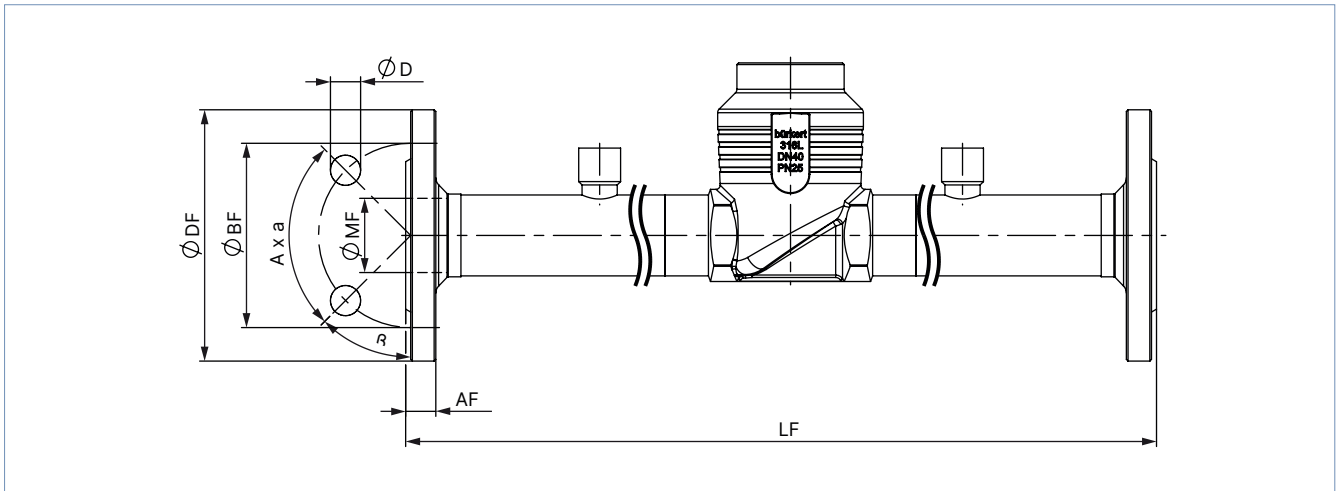

Nominal diameter DN	DIN EN 1092 PN 25							JIS 10K						
	Ø DF [mm]	LF [mm]	Ø BF [mm]	AF [mm]	Ø D [mm]	A x α	Ø MF [mm]	Ø DF [mm]	LF [mm]	Ø BF [mm]	AF [mm]	Ø D [mm]	A x α	Ø MF [mm]
15	95	330	65	16	14	4 × 90°	18.1	95	330	70	12	15	4 × 90°	18.1
25	115	500	85	18	14	4 × 90°	29.7	125	500	90	14	19	4 × 90°	29.7
40	150	700	110	18	18	4 × 90°	44.3	140	700	105	16	19	4 × 90°	44.3
50	165	800	125	20	18	4 × 90°	56.3	155	800	120	16	19	4 × 90°	56.3
65	185	1000	145	22	18	8 × 45°	66	175	1000	140	18	19	4 × 90°	71.5
80	200	1200	160	24	18	8 × 45°	81	185	1200	150	18	19	8 × 45°	84.3
100	235	1400	190	24	22	8 × 45°	100	292	1400	175	18	19	8 × 45°	109.1

Nominal diameter NPS	ANSI B 16.5 Class 150						
	Ø DF [mm]	LF [mm]	Ø BF [mm]	AF [mm]	Ø D [mm]	A x α	Ø MF [mm]
½"	89	330	60.5	11.2	15.7	4 × 90°	15.7
1"	108	500	79.2	14.2	15.7	4 × 90°	26.7
1½"	127	700	98.6	17.5	15.7	4 × 90°	40.9
2"	152	800	120.7	19.1	19.1	4 × 90°	52.6
2½"	178	1000	139.7	22.3	19.1	4 × 90°	62.7
3"	190	1200	152.5	23.9	19.1	4 × 90°	78
4"	229	1400	190.5	23.9	19.1	8 × 45°	102.4

DTS 1000089368 EN Version: T Status: RL (released | freigegeben | valide) printed: 22.01.2026

5. Performance specifications

5.1. Fluidic data

Flow characteristics

- Equal-percentage flow characteristic according to DIN EN 60534 - 2 - 4
- K_{VR} value at 5 % of the stroke for seat size > 10 mm
 K_{VR} value at 10 % of the stroke for seat size ≤ 10 mm
- K_V value [m³/h]: measurement with water according to DIN EN 60534 - 2 - 4
- K_{VR} value: smallest K_V value, at which the tilt tolerance according to DIN EN 60534 - 2 - 4 is still maintained

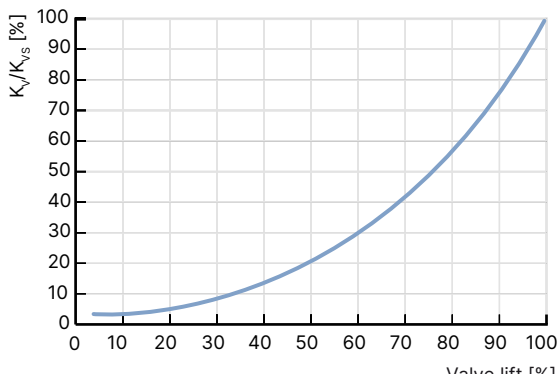

Equal percentage characteristics, detailed K_V values see below

Overview of fluidic data for flow under seat

Note:

We will be happy to design the appropriate valve size of the fluid quantity regulator for you (see [“8.4. Bürkert Product Enquiry Form”](#) on page 12).

Nominal diameter		Seat size	Actuator size	K_V value at stroke [m ³ /h]						K_{VS} value [m ³ /h]
DN	NPS			5 %	10 %	30 %	50 %	70 %	90 %	
15	½"	8	70 (M)	–	0.08	0.13	0.27	0.63	1.6	2.1
		10	70 (M)	–	0.11	0.19	0.49	1.1	2.5	3.1
		15	70 (M)	0.14	0.17	0.35	0.8	1.8	3.7	4.3
25	1"	15	70 (M)	0.14	0.17	0.35	0.8	1.8	4.1	5.3
		20	70 (M)	0.2	0.25	0.47	1.1	2.5	5.4	7.2
		25	70 (M)	0.35	0.38	1	2.2	5.1	9.4	12
40	1½"	25	90 (N)	0.38	0.48	0.95	1.9	3.7	7.2	9.4
		32	90 (N)	0.45	0.55	1.1	2.5	5	10.8	14.4
		40	90 (N)	0.55	0.67	1.5	3.2	6.5	13.6	17.5
50	2"	32	130 (P)	0.48	0.6	1.3	3.2	6.9	16	21
		40	130 (P)	0.6	0.7	1.7	4	9.2	18.9	24.5
		50	130 (P)	0.9	1.1	2.9	6.8	15.5	29.5	37
65	2½"	40	130 (P)	0.65	0.75	1.8	4.3	10.4	22	29
		50	130 (P)	1	1.2	3.1	6.7	16	35	45
		65	130 (P)	1.6	2	5	13.5	33	56	65
80	3"	50	130 (P)	1	1.2	3.4	8.3	19	35	45
		65	130 (P)	1.6	2	5	13	35	61	73
			225 (L)	1.4	1.7	3.8	8.2	19.5	50	70
		80	130 (P)	2.5	3.4	10.7	27	58	87	100
		225 (L)	2.1	2.6	7	16	40	83	100	

DTS 1000089368 EN Version: T Status: RL (released | freigegeben | valide) printed: 22.01.2026

Nominal diameter		Seat size	Actuator size	K _v value at stroke [m ³ /h]						K _{vs} value [m ³ /h]
DN	NPS			5 %	10 %	30 %	50 %	70 %	90 %	
100	4"	65	130 (P)	1.4	1.8	5	15	37	64	77
			225 (L)	1.4	1.7	3.8	8.3	20	51	75
		80	130 (P)	2.2	3.1	10.3	30	66	97	110
			225 (L)	2.1	2.6	7	17	44	89	115
		100	130 (P)	3.8	5.2	15	46.5	90	128	140
			225 (L)	3.2	3.9	9	20.5	51	118	140

6. Product operation

6.1. Flow measurement principle

The valve seat of the control valve represents a variable orifice. By measuring the pressure upstream and downstream of this orifice as well as a programmed flow characteristic of the corresponding valve, the current flow rate can be determined. The flow rate is compared with the flow setpoint transmitted to the device. In the event of a control deviation, the valve and thus the orifice are adjusted exactly so that the setpoint and actual value match. To determine the flow rate, the density of the gas and the reference conditions, among other things, must be set in the controller during commissioning. The temperature of gas that is usually present is also permanently programmed in. The control parameters of the PI controller must also be determined and set during commissioning. If the outlet pressure fluctuates, the unit automatically reacts to this by detecting a control deviation between the setpoint and actual value and adjusting the valve so that this deviation disappears.

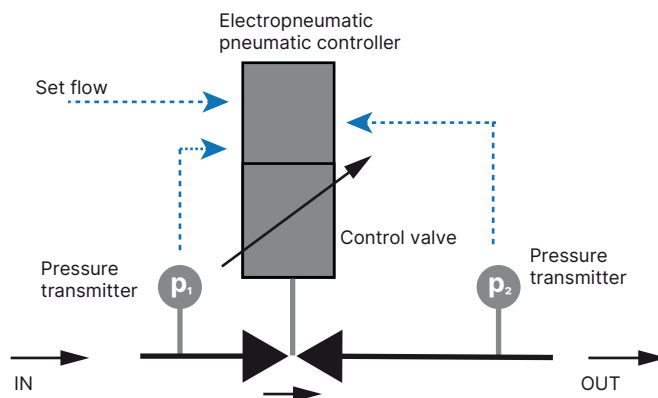

7. Product installation

7.1. Piping upstream of the fluid flow regulator

For high accuracy, the inlet distances upstream of the fluid quantity regulator must be observed in accordance with EN ISO 5167 - 1. The outlet section downstream of the valve is already integrated in the system. Depending on the installation situation, an inlet distance corresponding to 15...20 times the pipe diameter is recommended.

DTS 1000089368 EN Version: T Status: RL (released | freigegeben | valide) printed: 22.01.2026

7.2. Electrical connections

Multipole connection

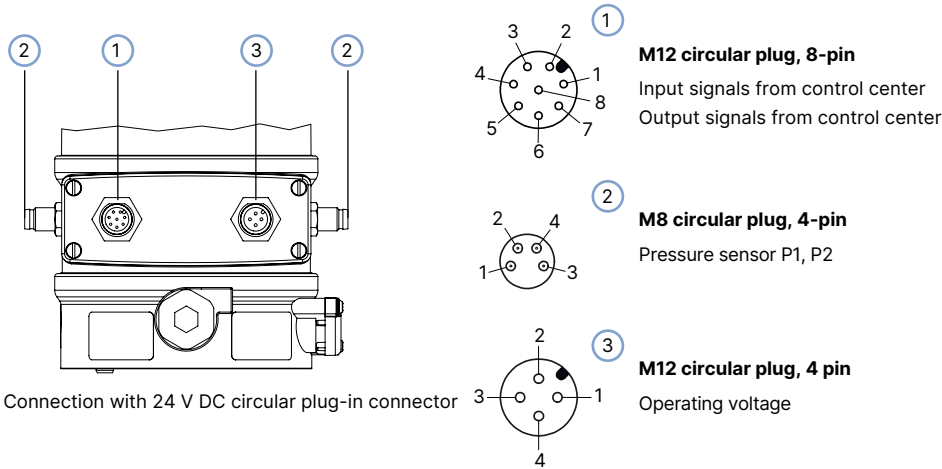

M12 circular plug, 8-pin		
Pin	Wire colour ¹⁾	Assignment
Set-point value, digital input		
1	White	Digital input +
7	Blue	Set-point value GND
8	Red	Set-point value + (0/4...20 mA / 0...5/10 V)
Input/output signals		
2	Brown	Digital output GND
3	Green	Digital output 2
4	Yellow	Digital output 1
5	Grey	Analogue position feedback GND
6	Pink	Analogue position feedback +

1.) The indicated wire colours refer to the connection cable available as an accessory with the article no. 919267.

M8 circular plug, 4-pin (pressure sensor)		
Pin	Wire colour	Assignment
Set-point value, digital input		
1	Brown	+ 24 V pressure sensor power supply
2	White	4...20 mA output from pressure sensor

M12 circular plug, 4-pin (operating voltage)		
Pin	Wire colour ¹⁾	Assignment
Set-point value, digital input		
1	Brown	Operating voltage + 24 V DC
3	Blue	Operating voltage GND

1.) The indicated wire colours refer to the connection cable available as an accessory with the article no. 919267.

DTS 1000089368 EN Version: T Status: RL (released | freigegeben | valide) printed: 22.01.2026

PROFIBUS DPV1

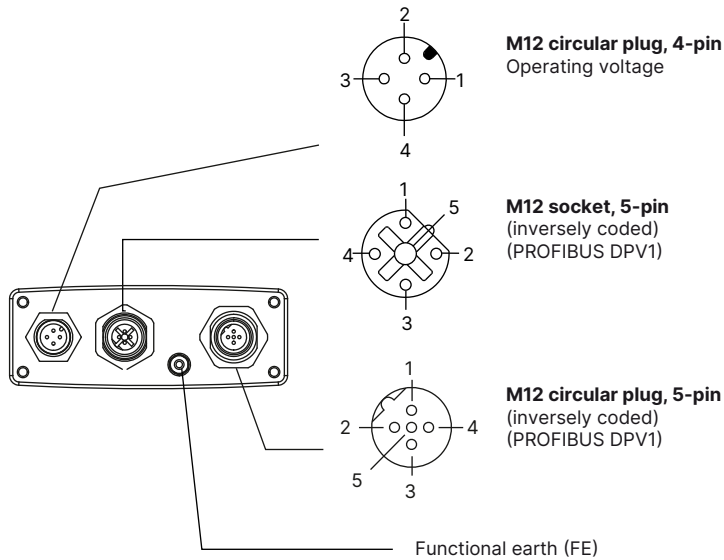

M12 socket/circular plug, 5-pin, fieldbus connection

Pin	Configuration
1	VP+ 5
2	RxD/TxD-N
3	DGND
4	RxD/TxD-P
5	Not connected
Thread	Shielding

M12 circular plug, 4-pin, operating voltage

Pin	Wire colour ^{1.)}	Configuration
1	Brown	+ 24 V
3	Blue	GND

1.) The indicated wire colours refer to the connection cable available as an accessory with the article no. 918038.

8. Ordering information

8.1. Bürkert eShop



Bürkert eShop – Easy ordering and quick delivery

You want to find your desired Bürkert product or spare part quickly and order directly? Our online shop is available for you 24/7. Sign up and enjoy all the benefits.

[Order online now](#)

8.2. Recommendation regarding product selection

Note:

Use the Product Enquiry Form (see “8.4. Bürkert Product Enquiry Form” on page 12) for information on the device layout and send it to us once completed.

For the proper choice of the actuator orifice within the MFC, you need to know not only the required maximum flow rate Q_N but also the pressure values directly upstream and downstream of the MFC (p_1, p_2) at Q_N . These are not identical to the inlet and outlet pressure of the entire system, because there are usually additional flow resistances (pipework, additional shut-off valves, nozzles, etc.) both upstream and downstream of the MFC.

Please use the Product Enquiry Form to indicate the pressures directly upstream and downstream of the MFC. If the pressure values are unknown or not accessible to measurement, estimates are to be made by taking into account the approximate pressure drops over the flow resistors upstream and downstream of the MFC at Q_N . The maximum expected inlet pressure p_{1max} must be specified to ensure the tight-closing function of the actuator in all operating states.

8.3. Bürkert product filter



Bürkert product filter – Get quickly to the right product

You want to select products comfortably based on your technical requirements? Use the Bürkert product filter and find suitable articles for your application quickly and easily.

[Try out our product filter](#)

8.4. Bürkert Product Enquiry Form

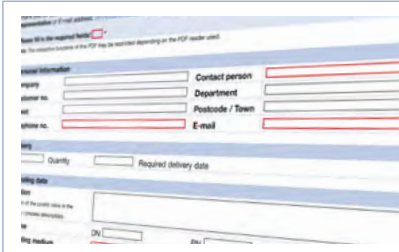

Bürkert Product Enquiry Form – Your enquiry quickly and compactly

Would you like to make a specific product enquiry based on your technical requirements? Use our Product Enquiry Form for this purpose. There you will find all the relevant information for your Bürkert contact. This will enable us to provide you with the best possible advice.

[Fill out the form now](#)

8.5. Ordering chart flange

Note:

- Flange according to DIN EN 1092 - 1 with PTFE valve seat seal
- For the design of the fluid flow controller, please contact your sales centre or use the **Product Enquiry Form** (see “8.4. Bürkert Product Enquiry Form” on page 12).

Nominal diameter and seat size	Actuator size	K_{vs} value [m ³ /h]	Pressure measurement range [bar]	Air volume ¹⁾ at $p_1 = 6 \text{ bar}, p_2 = 3 \text{ bar}$		Article no.
				Q_{max} [Nm ³ /h]	Q_{min} [Nm ³ /h]	
DN 15	M (70 mm)	4.3	0...10	350	20	20098580
DN 25	M (70 mm)	12	0...10	900	40	20090409
DN 40	N (90 mm)	17.5	0...10	1300	70	20124784
DN 50	P (130 mm)	37	0...10	2900	120	20089220
DN 65	P (130 mm)	65	0...10	5500	200	20090412
DN 80	P (130 mm)	100	0...10	8500	350	20090414
DN 100	P (130 mm)	140	0...6	12000	500	20125250

1.) For reference, the air volume ranges are listed at a typical inlet pressure of 6 bar. The values refer to air at a temperature of + 20 °C. The ranges apply to the valve position range of 10%...90%.

Further variants on request	
>	Additional <ul style="list-style-type: none"> • Specific pressure ranges • Alternative seat seals • Reduced control pressure from 3.5 bar

8.6. Ordering chart accessories

Note:

Spare parts for the valve seat and control cone can be ordered in the form of spare parts sets. Refer to the **operating instructions Type 8750 ▶** for the appropriate article no.

Description	Article no.
M12 socket, 8-pin with 5 m cable	919267
M12 socket, 4-pin with 5 m cable	918038
USB büS interface set 2 (Type 8923) for connection to the Bürkert Communicator software: including büS stick, connection cable to M12 plug, M12 connection cable on micro USB for the büS service interface and Y distributor, cable length: 0.7 m	772551
USB interface for serial communication (only for PROFIBUS)	227093
Sensor puck (spare part)	682240
Bürkert Communicator Software	Type 8920 ▶
Silencer G 1/8	780779

DTS 1000089368 EN Version: T Status: RL (released | freigegeben | valide) printed: 22.01.2026