





Flowmeter for gases

- Depth scale for accurate installation in existing pipes
- Usable in pipes from 1/2" up to 12" (DN 300)
- Easy installation under pressure
- Integrated display
- Standard variant and heavy duty variant available

Product variants described in the data sheet may differ from the product presentation and description.

Can be combined with

- 
Type 3280 ▶
 Electromotive 2-way globe proportional valve

- 
Type 3285 ▶
 Electromotive 2-way globe proportional valve

- 
Type 8611 ▶
 eCONTROL - Universal controller

- 
Type 8802 ▶
 ELEMENT continuous control valve systems - overview

- 
Type BUPLUS ▶
 Service, Maintenance and Commissioning

Type description

This flowmeter series measures especially large flow rates and use the calorimetric measuring principle. A heated sensor element is cooled down by the gas flow. This cooling effect which depends on the flow velocity and the gas characteristics serves as a flow indication. The kind of cooling directly depends on the flow velocity and the kind of gas. This kind of mass flow measurement is independent of pressure and temperature. The flowmeter can be used for monitoring air supplies, but also qualifies for the measurement of other gases.

Type 8007 is available in two variants: standard and heavy duty.

In the heavy duty variant, the sensor is encapsulated in stainless steel.

DTS 1000195999 EN Version: Q Status: RL (released | freigegeben | valide) printed: 07.05.2026

Table of contents

1. General technical data	3
<hr/>	
2. Approvals and conformities	3
2.1. General notes	3
2.2. Conformity	3
2.3. Standards	3
<hr/>	
3. Materials	4
3.1. Bürkert resistApp	4
<hr/>	
4. Dimensions	4
4.1. Standard variant	4
4.2. Heavy duty variant	5
<hr/>	
5. Device/Process connections	6
5.1. Pin assignment for standard variant	6
5.2. Heavy duty variant	7
<hr/>	
6. Product installation	8
6.1. Mounting options	8
6.2. Installation notes	8
<hr/>	
7. Product operation	9
7.1. Flow ranges	9
<hr/>	
8. Ordering information	9
8.1. Bürkert eShop	10
8.2. Bürkert product filter	10
8.3. Ordering chart for air with 6 bar operating pressure, standard variant	10
8.4. Ordering chart for air with 6 bar operating pressure, heavy duty variant	10
8.5. Ordering chart accessories, standard variant	11

DTS 1000195999 EN Version: Q Status: RL (released | freigegeben | valide) printed: 07.05.2026

1. General technical data

Product properties	
Dimensions	Further information can be found in chapter "4. Dimensions" on page 4.
Materials	
Seal	NBR, FKM (for oxygen)
Body	Standard variant: stainless steel 1.4301/304, heavy duty variant: stainless steel 1.4571/316Ti
Electronics housing	Standard variant: polycarbonate, heavy duty variant: die-cast aluminium ¹⁾
Probe length	Standard variant: 220 mm, other lengths on request
Performance data	
Nominal flow range (Q _N)	Up to 44,030 Nm ³ /h (air) Further information can be found in chapter "7.1. Flow ranges" on page 9.
Maximum operating pressure ²⁾	Standard variant: max. 16 bar, optionally up to PN 40 Heavy duty variant: max. 50 bar
Measuring accuracy ³⁾	± 1.5 % of reading ± 0.3 % FS, based on air and in consideration of the specified inlet and outlet distances
Measuring span	1:50
Electrical data	
Operating voltage	18...36 V DC
Power consumption	5 W
Output signal	4...20 mA
Load	Maximum load: 500 Ω (current output)
Medium data	
Operating medium	Air, nitrogen, oxygen, natural gas, methane, argon
Calibration medium	Air
Medium temperature	- 30 °C...+ 110 °C (higher temperatures on request)
Process/Port connection & communication	
Digital communication interfaces	Modbus RS485/RTU
Port connection	G ½" (other connections on request)
Approvals and conformities	
Certificate	Material certificate 3.1 (on request)
Degree of protection	IP65
Environment and installation	
Ambient temperature	- 30 °C...+ 80 °C (higher temperatures on request)

1.) Silicone-free cleaning on request

2.) Overpressure to atmospheric pressure

3.) If the operating medium is different from the calibration medium, the actual measurement accuracy might vary from the indicated value.

2. Approvals and conformities

2.1. General notes

Note:

- The approvals and conformities listed below must be stated when making enquiries. This is the only way to ensure that the product complies with all required specifications.
- Not all available variants can be supplied with the below mentioned approvals or conformities.

2.2. Conformity

In accordance with the Declaration of Conformity, the product is compliant with the EU Directives.

2.3. Standards

The applied standards which are used to demonstrate compliance with the EU Directives are listed in the EU-Type Examination Certificate and/or the EU Declaration of Conformity.

3. Materials

3.1. Bürkert resistApp

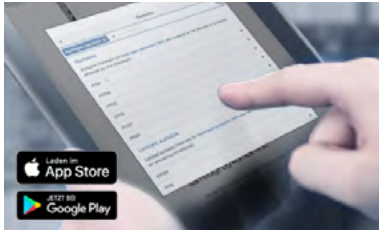

Bürkert resistApp – Chemical Resistance Chart

You want to ensure the reliability and durability of the materials in your individual application case? Verify your combination of media and materials on our website or in our resistApp.

[Start Chemical Resistance Check](#)

4. Dimensions

4.1. Standard variant

Note:

Dimensions in mm

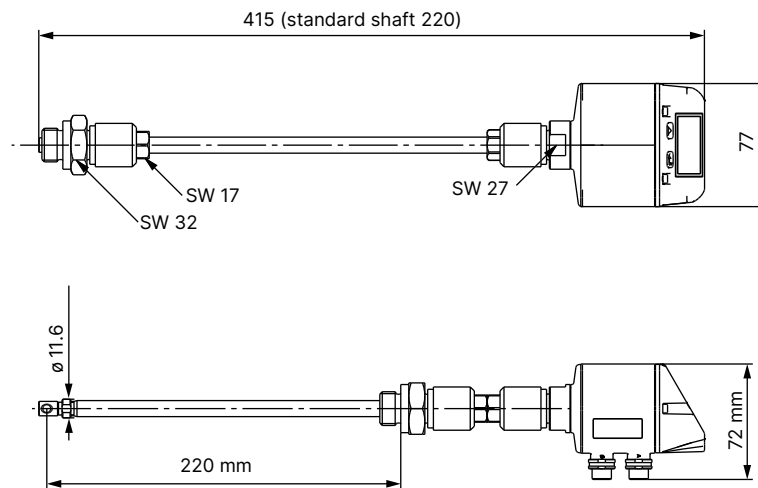

4.2. Heavy duty variant

Note:

Dimensions in mm

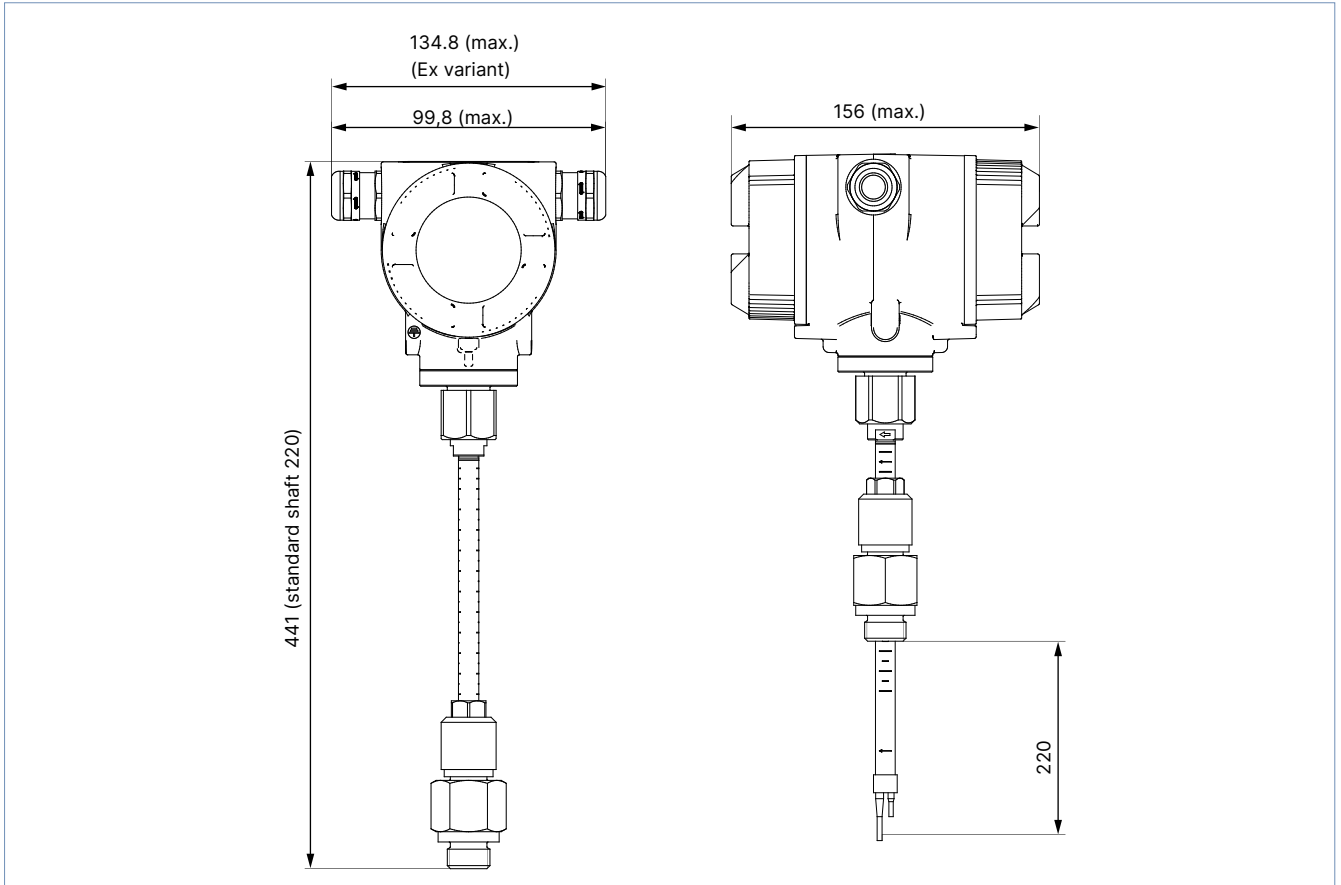

5. Device/Process connections

5.1. Pin assignment for standard variant

Note:

If the sensor is placed at the end of the Modbus system, a termination is required. The sensors have an internal switchable termination. To use the termination, release the 6 fastening screws from the lid and set the internal DIP switch to "On". When reassembling, ensure that the housing seal is correctly seated. Alternatively, a 120R resistor can be installed in the plug between pin 2 and pin 4.

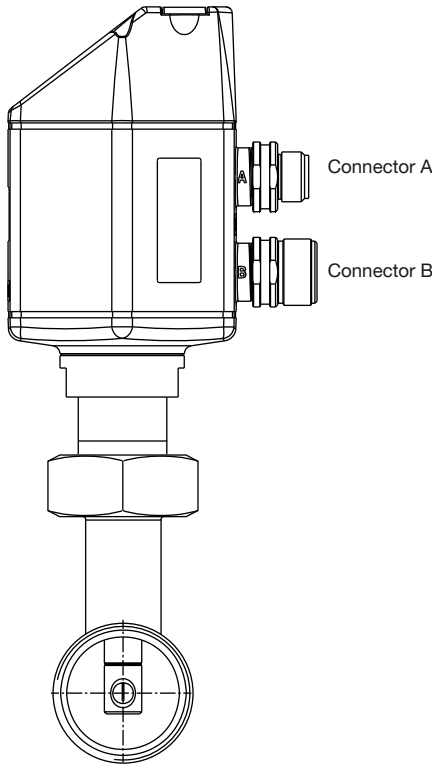

M12 connector

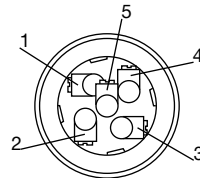

M12 connector A

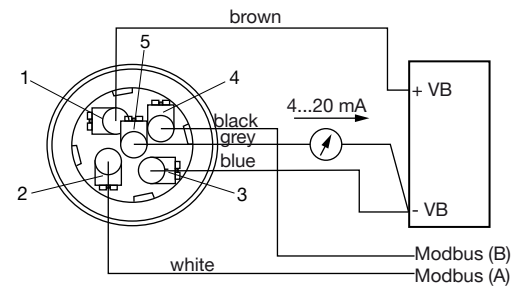

M12 connector B

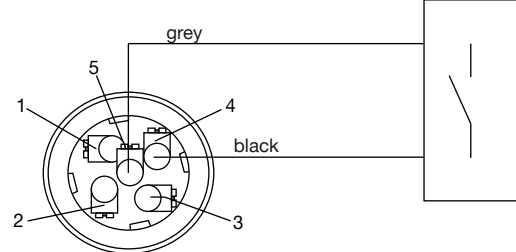

Pin	Connector A (connection port)	Connection cable A	Connector B (pulse port)	Connection cable B
1	VB + Positive power supply 12...36 V DC, smoothed	Brown	Not assigned, for internal use only ¹⁾	Brown
2	RS 485 (A) Modbus-RTU A	White	GND	White
3	VB - Negative power supply 12...36 V DC, smoothed	Blue	DIR Direction input	Blue
4	RS 485 (B) Modbus-RTU B	Black	P Pulse for usage	Black
5	I + Current signal 4...20 mA, selected measurement signal	Grey	P Pulse for usage	Grey

1.) Do not connect Pin 1 (connector B) with an electrical potential and/or ground.

5.2. Heavy duty variant

Note:

If the sensor is used at the end of the Modbus system, a bus termination is required. Connect the enclosed 120R resistor to the terminals, Pin 1 and 3 of X2 connector.

Plug layout

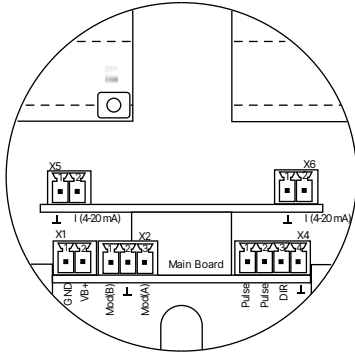

Voltage supply

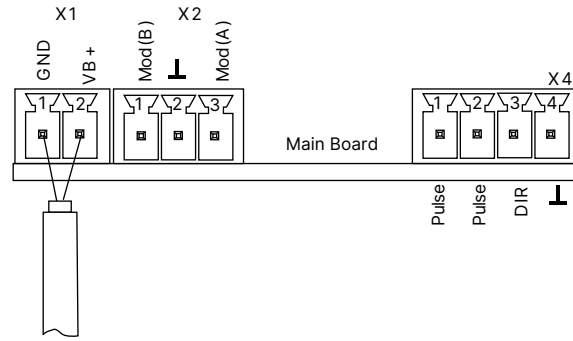

Modbus

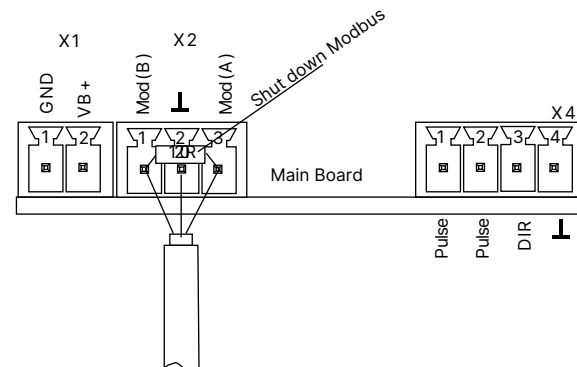

Pin	Plug	Description
1	X1	VB - (negative supply voltage GND)
2	Voltage supply	VB + (positive supply voltage 12...36 V DC)
1	X2	Modbus (B)
2	Modbus	Modbus shield
3		Modbus (A)
1	X4	Pulse/alarm ¹⁾
2	Direction/impulse	Pulse/alarm ¹⁾
3		Direction input
4		GND
1	X5	I - Active ¹⁾
2	Power output 1	I + Active ¹⁾
1	X6	I - Active ¹⁾
2	Power output 2	I + Active ¹⁾

1.) All analogue outputs are galvanically isolated.

6. Product installation

6.1. Mounting options

Note:

In order to get the accuracy specified in the data sheets, the sensor must be inserted in the centre of a straight pipe section with an undisturbed gas stream.

To obtain an undisturbed gas stream, the sections in front of and behind the sensor must be straight, long enough and without any obstructions such as edges, seams, curves etc.

Pay attention to the design of the outlet section as obstructions can cause counter-flow turbulences as well as turbulences in flow direction.

Installation in pipes at pressures > 10 bar requires a high-pressure safety device.

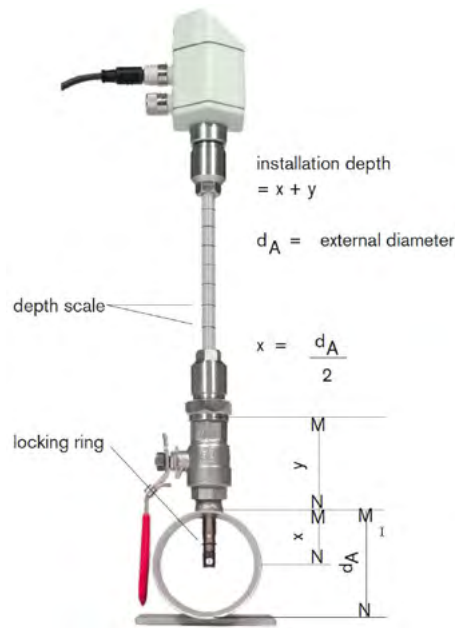

6.2. Installation notes

Note:

The principle of thermal mass flow measurement used here is very sensitive to flow disturbances. It is therefore necessary to observe the recommended inlet and outlet sections.

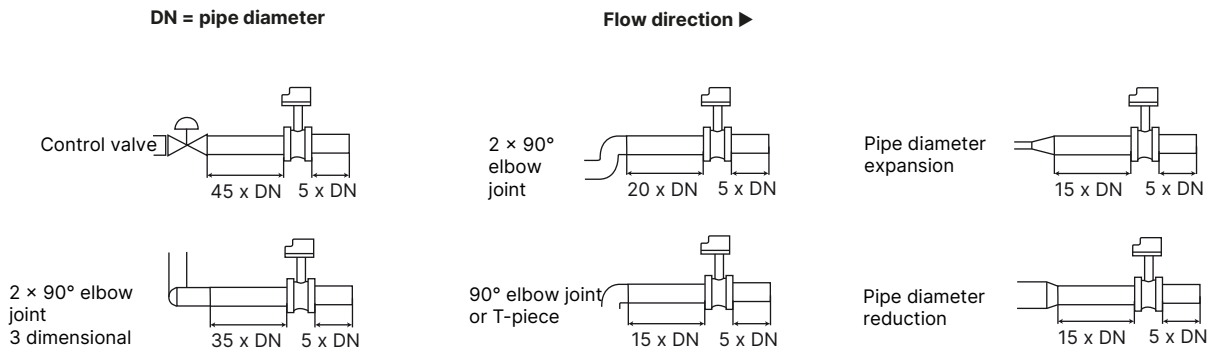

Table of additionally required inlet sections

Flow obstacle in front of the measuring section	Minimum inlet section (L1)	Minimum outlet section (L-L1)
Minimum curvature (elbow joint < 90°)	12 x D	5 x D
Pipe diameter reduction (pipe narrows in the direction of the measuring section)	15 x D	5 x D
Pipe diameter expansion (pipe expands in the direction of the measuring section)	15 x D	5 x D
90° elbow joint or T-piece	15 x D	5 x D
2 x 90° elbow joint on one level	20 x D	5 x D
2 x 90° elbow joint (3-dimensional change of direction)	35 x D	5 x D
Control valve	45 x D	5 x D

7. Product operation

7.1. Flow ranges

Note:

- According to DIN 1343, with 0 °C and 1013 mbar abs, to convert to DIN 1945 (ISO 1217), at 20 °C and 1000 mbar multiply with 1.087
- For other internal pipe diameters see **operating instructions Type 8007** ▶
- Flow ranges depend on the product variant of Type 8007 (Basic, Extended, Maximum) and the internal pipe diameter.
- The sensor can be installed in any specified pipe size. The presetting of the sensor ex works applies to a 2" pipe (53.1 mm inner diameter).
- Each version is calibrated to a flow velocity range:
 - Basic variant up to max. 92.7 m/s
 - Extended variant up to max. 185 m/s
 - Maximum variant up to max. 224 m/s

Type 8007 without display:

The scaling of the 4...20 mA output is carried out in the signal receiver, e.g. the programmable logic controller, using the measuring range table.

Type 8007 with display:

For the scaling of the 4...20 mA output, the specific pipe size (inner diameter) can be entered via the display and the keys. Furthermore, the desired flow unit can be selected.

Pipe [inch]	Inner pipe diameter [mm]	Basic variant		Extended variant		Maximum variant	
		Velocity [m/s]	Max. flow range [Nm ³ /h]	Velocity [m/s]	Max. flow range [Nm ³ /h]	Velocity [m/s]	Max. flow range [Nm ³ /h]
½	16.1	92.7	41	185	80	224	100
¾	21.7		81		160		195
1	27.3		136		270		325
1¼	36		244		485		590
1½	41.9		335		665		810
2	53.1		550		1100		1330
2½	71.1		1005		2010		2435
3	84.9		1440		2880		3485
4	110		2430		4850		5875
5	133.7		3595		7180		8690
6	159.3		5110		10200		12355
8	200		8075		16120		19520
10	250	12635	25220	30540			
12	300	18220	36360	44030			

8. Ordering information

8.1. Bürkert eShop



Bürkert eShop – Easy ordering and quick delivery

You want to find your desired Bürkert product or spare part quickly and order directly? Our online shop is available for you 24/7. Sign up and enjoy all the benefits.

[Order online now](#)

8.2. Bürkert product filter



Bürkert product filter – Get quickly to the right product

You want to select products comfortably based on your technical requirements? Use the Bürkert product filter and find suitable articles for your application quickly and easily.

[Try out our product filter](#)

8.3. Ordering chart for air with 6 bar operating pressure, standard variant

Note:

- Calibration for other gases on request
- Probe lengths 120 mm, 160 mm, 300 mm, 400 mm on request

Description	Article no.
Type 8007 with integrated display, Basic variant [air 92.7 m/s], probe length: 220 mm	773498
Type 8007 with integrated display, Extended variant [air 185 m/s], probe length: 220 mm	773499
Type 8007 with integrated display, Maximum variant [air 224 m/s], probe length: 220 mm	773500

8.4. Ordering chart for air with 6 bar operating pressure, heavy duty variant

Note:

- Calibration for other gases on request
- Probe lengths 120 mm, 160 mm, 300 mm, 400 mm on request





Description	Article no.
Type 8007 with integrated display, Basic variant [air 92.7 m/s], probe length: 220 mm	773508
Type 8007 with integrated display, Extended variant [air 185 m/s], probe length: 220 mm	773509
Type 8007 with integrated display, Maximum variant [air 224 m/s], probe length: 220 mm	773510

DTS 1000195999 EN Version: Q Status: RL (released | freigegeben | valide) printed: 07.05.2026

8.5. Ordering chart accessories, standard variant

Note:

Without ordering cables, the flow meter is delivered with an M12 connector for port A.

Description	Article no.
5 m cable, assembled on one side with M12 socket, 5-pin	770217 
10 m cable, assembled on one side with M12 socket, 5-pin	770795 
Power supply unit Phoenix Class2 (Type 1573), 85...240 V AC/24 V DC, 1.25 A, NEC Class 2 (UL 1310)	772438 
Power supply unit for standard rail (Type 1573), 100...240 V AC/24 V DC, 1 A, NEC Class 2 (UL 1310)	772361 
Power supply unit for standard rail (Type 1573), 100...240 V AC/24 V DC, 2 A, NEC Class 2 (UL 1310)	772362 
Power supply unit for standard rail (Type 1573), 100...240 V AC/24 V DC, 3.8 A, NEC Class 2 (UL60950 -1)	772898 