



Diaphragm valve, 2/2-way, servo-assisted

- Servo-assisted diaphragm valve up to DN20
- Medium-separated
- Body available in brass, stainless steel and plastic
- Circuit function NC and NO



Product variants described in the data sheet may differ from the product presentation and description.

Can be combined with



Type 2516
Cable plug,
form C according to
DIN EN 175301-803

Type description

Type 6212 is a pilot-operated 2/2-way solenoid valve with servo diaphragm. The actuator is separated from the medium by a separating diaphragm. This allows use with slightly aggressive media. The housing program includes brass, stainless steel and plastic. The valve requires little electrical power, is lightweight and has a compact design. The special design and geometry of the valve internal parts ensure a soft closing function with only very low pressure peaks.

Table of contents

1. General technical data	3
2. Circuit functions	3
3. Approvals and conformities	4
3.1. General notes	4
3.2. Conformity	4
3.3. Standards	4
3.4. Drinking water	4
4. Materials	5
4.1. Bürkert resistApp	5
4.2. Material specifications	5
5. Dimensions	6
5.1. Standard variant with brass body or stainless steel body	6
6. Ordering information	7
6.1. Bürkert eShop	7
6.2. Bürkert product filter	7
6.3. Bürkert Product Enquiry Form	7
6.4. Ordering chart	8
Standard variant with brass body	8
Standard variant with stainless steel body	9
6.5. Ordering chart accessories	10
Three-part connection set made of PPE/PA	10
Cable plug Type 2516, form C according to DIN EN 175301 - 803	10

DTS 1000617090 EN Version: B Status: RL (released | freigegeben | valide) printed: 13.02.2026

1. General technical data

Product properties	
Dimensions	Further information can be found in chapter "5. Dimensions" on page 6 .
Material	
Seal	NBR, EPDM, FKM
Pilot flange body	PPS
Body	Brass, stainless steel
Housing cover	Stainless steel
Orifice	DN 10...DN 20
Circuit function	A and B Further information can be found in chapter "2. Circuit functions" on page 3.
Performance data	
Duty cycle	100 % continuous operation (with 24 V DC)
Switching time ¹⁾	Opening: 0.1...0.5 sec Closing: 0.2...2.2 sec
Electrical data	
Operating voltage	24 V DC (further voltages on request)
Power consumption	3.4 W
Voltage tolerance	± 10 %
Medium data	
Operating medium	Neutral and slightly aggressive gases and liquids which do not attack the housing and sealing materials. Further information can be found in chapter "4.1. Bürkert resistApp" on page 5 .
Medium temperature	
With NBR	+ 32 °F...+ 122 °F
With EPDM	+ 14 °F...+ 122 °F
With FKM	+ 32 °F...+ 122 °F
Viscosity	Max. 21 cSt (21 mm ² /s)
Product connections	
Electrical connection	Plug contacts according to DIN EN 175301 - 803 form C for cable plug Type 2516 ▶. (Plug contact sideways at 24 V DC, see "5. Dimensions" on page 6)
Port connections	NPT ¼ ...NPT 1 (G on request) Threaded sockets NPT ⅜, NPT ½ (with PPE/PA housing) Further information can be found in chapter "Three-part connection set made of PPE/PA" on page 10.
Approvals and conformities	
Degree of protection	IP65 with cable plug
Environment and installation	
Installation position	As required, preferably with actuator upright
Ambient temperature	Max. + 131 °F (with PPE/PA housing + 122 °F)

1) Measurement at + 68 °F, 87 psi at the valve outlet, opening: pressure build-up 0...90 %, closing: pressure reduction 100...10 %

2. Circuit functions

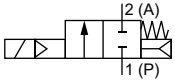
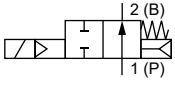
Symbol	Description
	Circuit function A (CF A) 2/2-way solenoid valve Servo-controlled Normally closed
	Circuit function B (CF B) 2/2-way solenoid valve Servo-controlled Normally open

3. Approvals and conformities

3.1. General notes

- The approvals and conformities listed below must be stated when making enquiries. This is the only way to ensure that the product complies with all required specifications.
- Not all available variants can be supplied with the below mentioned approvals or conformities.

3.2. Conformity

In accordance with the Declaration of Conformity, the product is compliant with the EU Directives.

3.3. Standards

The applied standards which are used to demonstrate compliance with the EU Directives are listed in the EU-Type Examination Certificate and/or the EU Declaration of Conformity.

3.4. Drinking water

Conformity	Description
	<p>Suitable for use in drinking water applications (valid for nominal diameter 13) The materials comply with the assessment principles (UBA) for materials in contact with drinking water (TrinkwasserV).</p> <p>PF36: Suitable for products with a maximum temperature of + 60 °C (warm water)</p>

DTS 1000617090 EN Version: B Status: RL (released | freigegeben | valide) printed: 13.02.2026

4. Materials

4.1. Bürkert resistApp

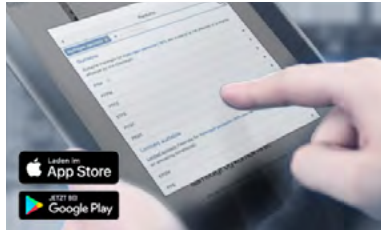

Bürkert resistApp – Chemical resistance chart

You want to ensure the reliability and durability of the materials in your individual application case? Verify your combination of media and materials on our website or in our resistApp.

[Start chemical resistance check](#)

4.2. Material specifications

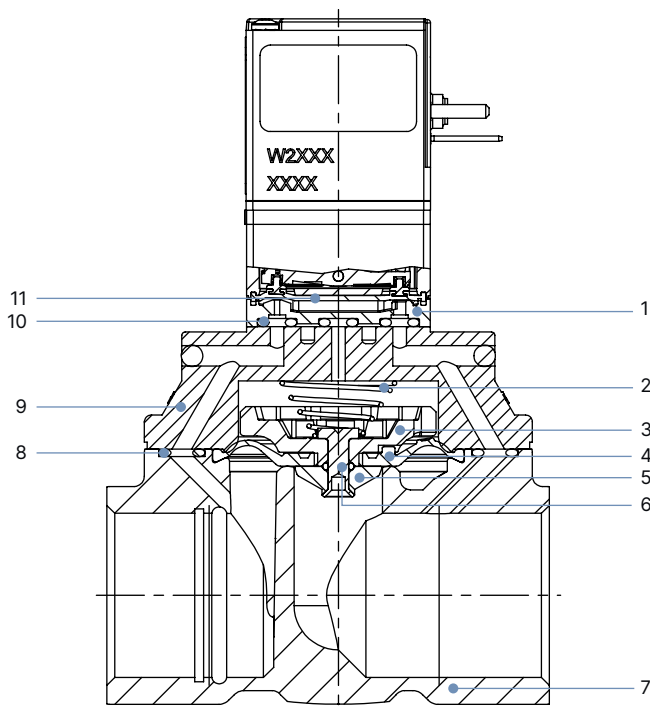

No.	Element	Material
1	Flange body	PPS
2	Pressure spring	Stainless steel
3	Diaphragm support	PPS
4	Diaphragm	NBR, FKM or EPDM
5	Diaphragm holder	PPS
6	Bolt	Brass or stainless steel
7	Valve body	Brass, stainless steel or PPE/PA
8	O-ring	FKM or EPDM
9	Cover	Stainless steel or PPE/PA
10	O-ring	NBR, FKM or EPDM
11	Separating diaphragm	FKM or EPDM

5. Dimensions

5.1. Standard variant with brass body or stainless steel body

Note:

Dimensions in mm [inch]

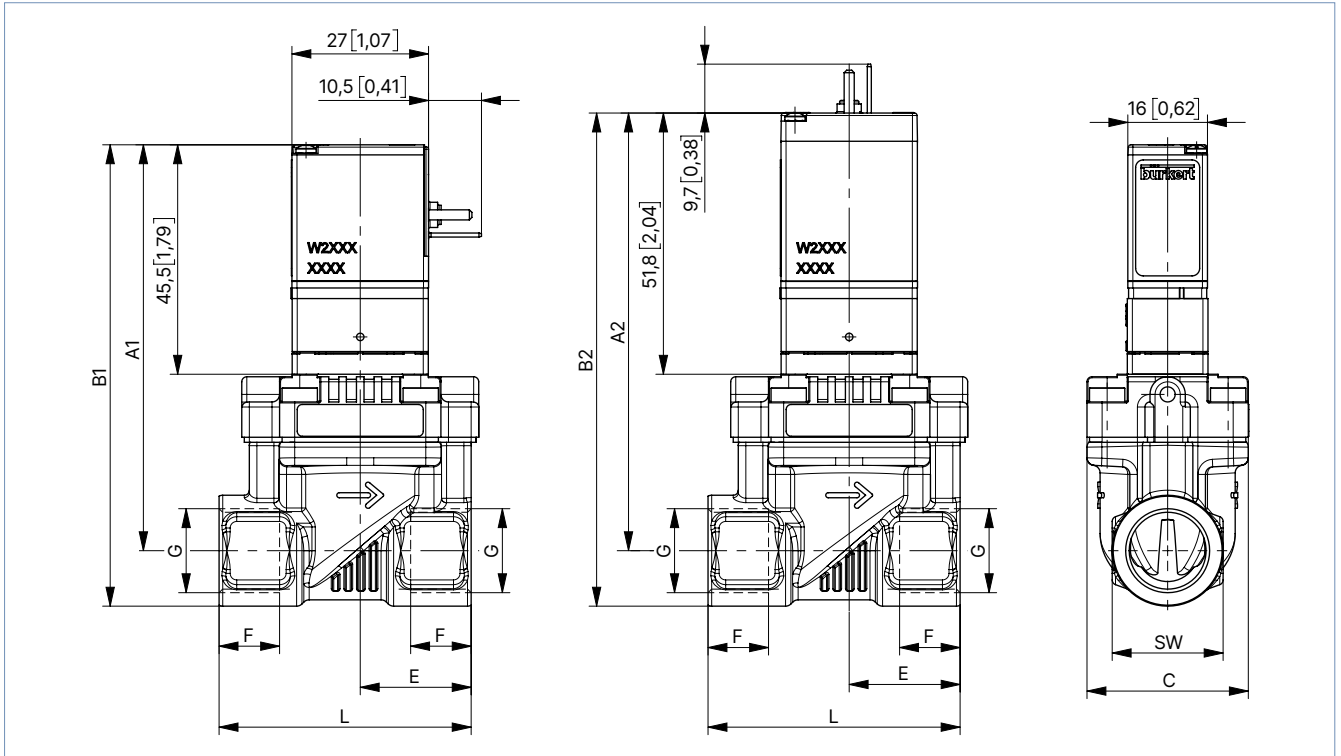

DN	Tag connectors sideways				Tag connectors above				C		E		F		G	L		SW	
	A1		B1		A2		B2		[mm]	[inch]	[mm]	[inch]	[mm]	[inch]	[inch]	[mm]	[inch]	[mm]	[inch]
	[mm]	[inch]	[mm]	[inch]	[mm]	[inch]	[mm]	[inch]											
10	80.5	1.26	91.5	3.60	86.8	3.42	97.8	3.85	32	1.26	22	0.87	12	0.47	G ¼	50	1.97	22	0.87
10	80.5	3.17	91.5	3.60	86.8	3.42	97.8	3.85	32	1.26	22	0.87	12	0.47	G ¾	50	1.97	22	0.87
10 ¹⁾	82.5	3.25	96	3.78	88.8	3.50	102.3	4.03	32	1.26	24.5	0.96	14	0.55	G ½	50	1.97	27	1.06
10 ²⁾	82.5	3.25	96	3.78	88.8	3.50	102.3	4.03	32	1.26	24.5	0.96	14	0.55	G ½	55	2.17	27	1.06
13	85	3.35	98.5	3.88	91.3	3.59	104.8	4.13	42	1.65	32.5	1.28	14	0.55	G ½	65	2.56	27	1.06
13	87	3.43	103	4.06	93.3	3.67	109.3	4.30	42	1.65	32.5	1.28	16	0.63	G ¾	65	2.56	32	1.26
20	94	3.70	114.5	4.51	100.3	3.95	120.8	4.76	60	2.36	50	1.97	16	0.63	G ¾	100	3.94	41	1.61
20	94	3.70	114.5	4.51	100.3	3.95	120.8	4.76	60	2.36	50	1.97	18	0.71	G 1	100	3.94	41	1.61

1.) Brass variant

2.) Stainless steel variant

6. Ordering information

6.1. Bürkert eShop



Bürkert eShop – Easy ordering and quick delivery

You want to find your desired Bürkert product or spare part quickly and order directly? Our online shop is available for you 24/7. Sign up and enjoy all the benefits.

[Order online now](#)

6.2. Bürkert product filter



Bürkert product filter – Get quickly to the right product

You want to select products comfortably based on your technical requirements? Use the Bürkert product filter and find suitable articles for your application quickly and easily.

[Try out our product filter](#)

6.3. Bürkert Product Enquiry Form

Note:

Please see our Product Enquiry Form for a full explanation of our specification key.

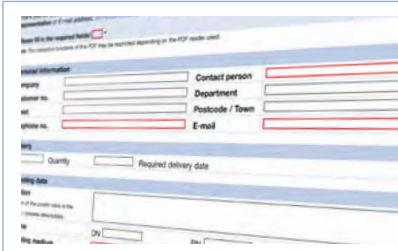

Bürkert Product Enquiry Form – Your enquiry quickly and compactly

Would you like to make a specific product enquiry based on your technical requirements? Use our Product Enquiry Form for this purpose. There you will find all the relevant information for your Bürkert contact. This will enable us to provide you with the best possible advice.

[Fill out the form now](#)

DTS 1000617090 EN Version: B Status: RL (released | freigegeben | valide) printed: 13.02.2026

6.4. Ordering chart

Standard variant with brass body

Note:

- Please note that the cable plug **Type 2516** ▶ is included. Further variants are available on request. For details see "**Cable plug Type 2516, form C according to DIN EN 175301-803**" on page 10.
- The electrical connection is located on the side.

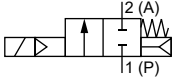
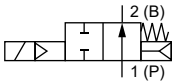
Circuit function	Port connection	Orifice	C _v value water ^{1.)}	Voltage/frequency	Pressure range ^{2.)}	Weight	Article no. NBR seal	Article no. FKM seal	Article no. EPDM seal
		[mm]	[gal/min]	[V/Hz]	[psi]	[lbs]			
Brass body, cover material PPE/PA, different sealing materials									
CF A 2/2-way solenoid valve Servo-controlled Normally closed 	NPT 3/8	10	2.2	024/DC	2.9...145 ^{3.)}	0.46	o. r.	o. r.	o. r.
	NPT 1/2					0.53			
	NPT 1/2	13	4.2	024/DC	2.9...145 ^{3.)}	0.64	o. r.	o. r.	o. r.
	NPT 3/4					0.73			
	NPT 3/4	20	9.6	024/DC	2.9...145 ^{3.)}	2.27	o. r.	o. r.	o. r.
	NPT 1					1.87			
CF B 2/2-way solenoid valve Servo-controlled Normally open 	NPT 3/8	10	2.2	024/DC	2.9...87 ^{3.)}	0.46	o. r.	o. r.	o. r.
	NPT 1/2					0.53			
	NPT 1/2	13	4.2	024/DC	2.9...87 ^{3.)}	0.64	o. r.	o. r.	o. r.
	NPT 3/4					0.73			
	NPT 3/4	20	9.6	024/DC	2.9...87 ^{3.)}	2.27	o. r.	o. r.	o. r.
	NPT 1					1.87			

o. r. = on request

1.) Measurement at + 68 °F, 14.5 psi^{2.)} at the valve inlet and free outlet

2.) Pressure data: overpressure to atmospheric pressure

3.) A differential pressure of 7 psi is required to open the full cross section.

DTS 1000617090 EN Version: B Status: RL (released | freigegeben | valide) printed: 13.02.2026

Standard variant with stainless steel body

Note:

- Please note that the cable plug **Type 2516** ▶ is included. Further variants are available on request. For details see **"Cable plug Type 2516, form C according to DIN EN 175301-803"** on page 10.
- The electrical connection is located on the side.

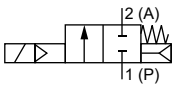
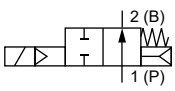
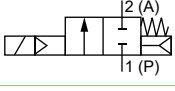
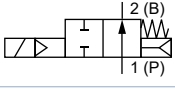
Circuit function	Port connection	Orifice	C _v value water ^{1.)}	Voltage/frequency	Pressure range ^{2.)}	Weight	Article no. NBR seal	Article no. FKM seal	Article no. EPDM seal
		[mm]	[gal/min]	[V/Hz]	[psi]	[lbs]			
Stainless steel body, cover material stainless steel, different sealing materials									
CF A 2/2-way solenoid valve Servo-controlled Normally closed 	NPT 3/8	10	2.2	024/DC	2.9...145 ^{3.)}	0.60	o. r.	o. r.	o. r.
	NPT 1/2					0.62	o. r.	o. r.	o. r.
	NPT 1/2	13	4.2	024/DC	2.9...145 ^{3.)}	0.84	o. r.	o. r.	o. r.
	NPT 3/4					0.90	o. r.	o. r.	o. r.
	NPT 3/4	20	9.6	024/DC	2.9...145 ^{3.)}	2.47	o. r.	o. r.	o. r.
	NPT 1					2.65	o. r.	o. r.	o. r.
CF B 2/2-way solenoid valve Servo-controlled Normally open 	NPT 3/8	10	2.2	024/DC	2.9...87 ^{3.)}	0.60	o. r.	o. r.	o. r.
	NPT 1/2					0.62	o. r.	o. r.	o. r.
	NPT 1/2	13	4.2	024/DC	2.9...87 ^{3.)}	0.84	o. r.	o. r.	o. r.
	NPT 3/4					0.90	o. r.	o. r.	o. r.
	NPT 3/4	20	9.6	024/DC	2.9...87 ^{3.)}	2.47	o. r.	o. r.	o. r.
	NPT 1					2.65	o. r.	o. r.	o. r.
Stainless steel body, cover material PA/PPE, different sealing materials									
CF A 2/2-way solenoid valve Servo-controlled Normally closed 	NPT 3/8	10	2.2	024/DC	2.9...145 ^{3.)}	0.49	o. r.	o. r.	o. r.
	NPT 1/2					0.57	o. r.	o. r.	o. r.
	NPT 1/2	13	4.2	024/DC	2.9...145 ^{3.)}	0.62	o. r.	o. r.	o. r.
	NPT 3/4					0.75	o. r.	o. r.	o. r.
	NPT 3/4	20	9.6	024/DC	2.9...145 ^{3.)}	2.27	o. r.	o. r.	o. r.
	NPT 1					1.87	o. r.	o. r.	o. r.
CF B 2/2-way solenoid valve Servo-controlled Normally open 	NPT 3/8	10	2.2	024/DC	2.9...87 ^{3.)}	0.49	o. r.	o. r.	o. r.
	NPT 1/2					0.57	o. r.	o. r.	o. r.
	NPT 1/2	13	4.2	024/DC	2.9...87 ^{3.)}	0.62	o. r.	o. r.	o. r.
	NPT 3/4					0.75	o. r.	o. r.	o. r.
	NPT 3/4	20	9.6	024/DC	2.9...87 ^{3.)}	2.27	o. r.	o. r.	o. r.
	NPT 1					1.87	o. r.	o. r.	o. r.

o. r. = on request

1.) Measurement at +68 °F, 14.5 psi^{2.)} at the valve inlet and free outlet

2.) Pressure data: overpressure to atmospheric pressure

3.) A differential pressure of 7 psi is required to open the full cross section.

Further variants on request

 Voltage Further voltages are available on request.	 Port connection G
 Material Housing material PPE/PA	

6.5. Ordering chart accessories

Three-part connection set made of PPE/PA

Note:

- You need two connection sets for one valve.
- The connection set is not included in the delivery and must be ordered separately.

Accessories	Port connection	Orifice	Seal material	Article no.
		[mm]	(O-ring)	
	G 3/8	10	NBR	142425
			FPM	142426
			EPDM	142427
	G 1/2	13	NBR	142428
			FPM	142429
			EPDM	142430

Cable plug Type 2516, form C according to DIN EN 175301 - 803

Note:

- Dimensions in mm
- The delivery of cable plug includes a flat seal and a fastening screw.
- For further variants see data sheet **Type 2516**

Cable plug	Dimensions	Variant	Voltage	Article no.
		Without wiring	0...250 V AC/DC	303141
		With LED	12...24 V AC/DC	303145
		With LED and varistor	12...24 V AC/DC	303148
		With rectifier, LED and varistor	12...24 V AC/DC	303142

DTS 1000617090 EN Version: B Status: RL (released | freigegeben | valide) printed: 13.02.2026