

Direct-acting 2/2-way direct-acting plunger valve

- Flushing and drainage valve in fuel cell systems and other hydrogen applications
- Very compact solenoid valve with reliably high tightness and service life
- Available with nominal diameters up to 6 mm
- Available as a flange or plug-in flange variant for fast system integration.
- Protection rating IP65 or IP6K9K with automotive plug

Product variants described in the data sheet may differ from the product presentation and description.

Can be combined with

	Type 2507 Cable plug, form B according to industry standard	▶
	Type 2509 Cable plug, form A according to DIN EN 175301 - 803	▶
	Type 2516 Cable plug, form C according to DIN EN 175301 - 803	▶
	Type 2518 Cable plug, form A according to DIN EN 175301 - 803	▶
	Type 6020 Direct-acting 2-way proportional valve	▶
	Type 6440 Servo-assisted 2/2-way piston valve	▶

Type description

Valve 6030 valve is a direct-acting plunger valve. The stopper and the core guide tube are welded together to increase pressure resistance and security against leaks. The coils are encased with an epoxy that is highly resistant to chemicals. In combination with a plug conforming to DIN EN 175301 - 803, the valves meet the IP65 protection rating. Cartridge and flange connections, and solenoids with automotive plugs with IP6K9K protection rating, are available for optimised use in fuel cells.

DTS 1000602619 EN Version: C Status: RL (released | freigegeben | validé) printed: 20.03.2025

Table of contents

1. General technical data	4
2. Circuit functions	5
3. Approvals and conformities	5
3.1. General notes	5
3.2. Conformity	5
3.3. Standards	5
3.4. Explosion protection.....	6
3.5. North America (USA/Canada)	6
4. Materials	7
4.1. Bürkert resistApp.....	7
4.2. Material specifications	7
5. Dimensions	8
5.1. Threaded variant.....	8
Coil size 24.5 mm (AC08)	8
Coil size 32 mm (AC10).....	9
5.2. Push-in flange variant	10
Coil size 24.5 mm (AC08)	10
Push-in flange connection diagram coil size 24.5 mm (AC08)	11
Coil size 32 mm (AC10).....	12
Push-in flange connection diagram coil size 32 mm (AC10)	13
5.3. Flange variant.....	14
Coil size 24.5 mm (AC08).....	14
Flange pattern coil size 24.5 mm (AC08)	15
Coil size 32 mm (AC10).....	16
Flange pattern coil size 32 mm (AC10)	17
5.4. ATEX/IECEx cable variant.....	18
Coil size 24.5 mm (AC08).....	18
Coil size 40 mm (AC10)	18
6. Performance specifications	19
6.1. Power consumption	19
7. Product accessories	19
7.1. Cable glands for ATEX/IECEx terminal box	19
7.2. Special tool to turn the terminal box	20
8. Ordering information	20
8.1. Bürkert eShop	20
8.2. Bürkert product filter.....	20
8.3. Bürkert Product Enquiry Form	20
8.4. Ordering chart	21
Standard variant with plug form B according to DIN EN 175301 - 803 (IP65 coil)	21
Standard variant with plug form A according to DIN EN 175301 - 803 (IP65 coil)	23
Variant with automotive plug (IP6K9K coil).....	24
Coil to be UL Listed for hazardous locations, Class I, Division 2.....	25

8.5.	Ordering chart accessories.....	26
	Cable plug Type 2507, form B according to industry standard.....	26
	Cable plug Type 2516, form C according to DIN EN 175301 - 803	26
	Cable plug Type 2518, form A according to DIN EN 175301 - 803	27
	Cable plug Type 2509, form A according to DIN EN 175301 - 803.....	27
	Cable glands for ATEX/IECEX terminal box.....	27

1. General technical data

Product properties		
Dimensions	Further information can be found in chapter "5. Dimensions" on page 8.	
Material		
Seal	EPDM	
Body	Stainless steel 1.4404/316L for push-in flange and flange body Stainless steel 1.4571/316Ti for threaded body	
Coil	Epoxy	
Tightness	1× 10 ⁻⁴ atm cc/s ¹⁾	
Pressure		
Nominal pressure class	Coil size 24.5 mm (AC08)	Coil size 32 mm (AC10)
	580 psi for threaded body	580 psi for threaded body
	580 psi for flange body	363 psi for flange body
Bursting pressure	290 psi for push-in flange body	73 psi for push-in flange body
	2900 psi for threaded body	2900 psi for threaded body
	2900 psi for flange body	1800 psi for flange body
	1450 psi for push-in flange body	363 psi for push-in flange body
Differential pressure	Further information can be found in chapter "8. Ordering information" on page 20.	
Orifice	DN 1...DN 6	
Circuit function	A Further information can be found in chapter "2. Circuit functions" on page 5.	
Thermal insulation class of solenoid coil	Epoxy coil class H	
Performance data		
Duty cycle	100 % continuous operation, 50% ED, 20% ED, see ordering chart To increase the duty cycle, the power can alternatively be reduced by means of current control or PWM signal after max. 500 ms.	
Switching time ²⁾	Coil size 24.5 mm (AC08)	Coil size 32 mm (AC10)
	Opening: 8...15 ms	Opening: 20 ms
	Closing: 10...17 ms	Closing: 30 ms
Electrical data		
Operating voltage	12 V DC, 24 V DC	
Power consumption	Further information can be found in chapter "6. Performance specifications" on page 19.	
Voltage tolerance		
Standard variant (IP65)	± 10 %	
Variants with automotive connection (IP6K9K)	12 V: 9 V...16 V	
	24 V: 18 V...32 V	
Medium data		
Operating medium	Neutral gases and liquids (e.g. compressed air, water, nitrogen) Optimised for DI water and hydrogen	
Medium temperature	- 40 °F...+ 212 °F	
Viscosity	Max. 21 mm ² /s (21 cSt)	
Process/Port connection and communication		
Electrical connection	<ul style="list-style-type: none"> Plug contacts according to DIN EN 175 301 - 803 form B for cable plug Type 2507 ▶ Further information can be found in chapter "Cable plug Type 2507, form B according to industry standard" on page 26. Plug contacts according to DIN EN 175 301 - 803 form C for cable plug Type 2516 ▶ Further information can be found in chapter "Cable plug Type 2516, form C according to DIN EN 175301 - 803" on page 26. Plug contacts according to DIN EN 175 301 - 803 form A for cable plug Type 2518 ▶ Further information can be found in chapter "Cable plug Type 2518, form A according to DIN EN 175301 - 803" on page 27. <p>Automotive connector for IP6K9K coil variant: Connector KOSTAL MLK1.2, 2-pin, coding A (male) Connector TE MCON 1.2, 2-pin, coding A (male) Other connector types available on request</p>	
Port connection	Push-in flange, flange, G 1/8, G 1/4	

Approvals and conformities

Explosion protection	Further information can be found in chapter “3.4. Explosion protection” on page 6.
North America (USA/Canada)	Further information can be found in chapter “3.5. North America (USA/Canada)” on page 6.

Degree of protection

Standard variant	IP65 with cable plug Type 2507 ▶ , Type 2516 ▶ and Type 2518 ▶ NEMA 4X with cable plug Type 2509 ▶ for stainless steel variants (further variants available on request)
Automotive coil	IP6K according to ISO 20653:2013 IPX7 according to ISO 20653:2013 (immersion test according to ISO 16750 - 4:2010) IPX9K according to ISO 20653:2013 This degree of protection can only be guaranteed as long as the coil is not removed from the valve.

Environment and installation

Installation position	As required, preferably with actuator upright
-----------------------	---

Ambient temperature

Standard variant	- 40 °F...+ 131 °F/+ 167 °F (depending on power level and voltage tolerance)
Automotive coil ³⁾	- 40 °F...+ 185 °F

- 1.) The limit values listed do not apply to valves with lower tightness requirements (var. code PC93). This restriction does not include a standard helium leak test.
- 2.) Measurement at + 68 °F, 87 psi at valve outlet, opening: pressure build-up 0...90 %, closing: pressure drop 100...10 %
- 3.) Depending on the variant, a power reduction by means of current control or PWM signal to 50 % of the nominal power (holding phase) may be necessary after max. 500 ms (switch-on pulse).

2. Circuit functions

Symbol	Description
	Circuit function A (CF A) 2/2-way solenoid valve Direct-acting Normally closed

3. Approvals and conformities

3.1. General notes

- The approvals and conformities listed below must be stated when making enquiries. This is the only way to ensure that the product complies with all required specifications.
- Not all available variants can be supplied with the below mentioned approvals or conformities.

3.2. Conformity



In accordance with the Declaration of Conformity, the product is compliant with the EU Directives.

3.3. Standards

The applied standards which are used to demonstrate compliance with the EU Directives are listed in the EU-Type Examination Certificate and/or the EU Declaration of Conformity.

DTS 1000602619 EN Version: C Status: RL (released | freigegeben | validé) printed: 20.03.2025

3.4. Explosion protection

Approval	Description				
 	<p>Optional: Explosion protection</p> <p>Ex marking of the components according to the following table:</p> <table border="1"> <thead> <tr> <th>Coil Type AC08</th> <th>Coil Type AC10</th> </tr> </thead> <tbody> <tr> <td> <p>ATEX: EPS 21 ATEX 1 128 X II 2G Ex mb IIC T4 Gb II 2D Ex mb IIIC T130 °C Db</p> <p>IECEX: IECEX EPS 21.0045X Ex mb IIC T4 Gb Ex mb IIIC T130 °C Db</p> </td> <td> <p>ATEX: EPS 18 ATEX 1232 X II 2G Ex mb IIC T4 Gb II 2D Ex mb IIIC T130 °C Db II 2G Ex eb mb IIC T4 Gb II 2D Ex mb tb IIIC T130 °C Db</p> <p>IECEX: IECEX EPS 18.0110 X Ex mb IIC T4 Gb Ex mb IIIC T130 °C Db Ex eb mb IIC T4 Gb Ex mb tb IIIC T130 °C Db</p> </td> </tr> </tbody> </table>	Coil Type AC08	Coil Type AC10	<p>ATEX: EPS 21 ATEX 1 128 X II 2G Ex mb IIC T4 Gb II 2D Ex mb IIIC T130 °C Db</p> <p>IECEX: IECEX EPS 21.0045X Ex mb IIC T4 Gb Ex mb IIIC T130 °C Db</p>	<p>ATEX: EPS 18 ATEX 1232 X II 2G Ex mb IIC T4 Gb II 2D Ex mb IIIC T130 °C Db II 2G Ex eb mb IIC T4 Gb II 2D Ex mb tb IIIC T130 °C Db</p> <p>IECEX: IECEX EPS 18.0110 X Ex mb IIC T4 Gb Ex mb IIIC T130 °C Db Ex eb mb IIC T4 Gb Ex mb tb IIIC T130 °C Db</p>
	Coil Type AC08	Coil Type AC10			
<p>ATEX: EPS 21 ATEX 1 128 X II 2G Ex mb IIC T4 Gb II 2D Ex mb IIIC T130 °C Db</p> <p>IECEX: IECEX EPS 21.0045X Ex mb IIC T4 Gb Ex mb IIIC T130 °C Db</p>	<p>ATEX: EPS 18 ATEX 1232 X II 2G Ex mb IIC T4 Gb II 2D Ex mb IIIC T130 °C Db II 2G Ex eb mb IIC T4 Gb II 2D Ex mb tb IIIC T130 °C Db</p> <p>IECEX: IECEX EPS 18.0110 X Ex mb IIC T4 Gb Ex mb IIIC T130 °C Db Ex eb mb IIC T4 Gb Ex mb tb IIIC T130 °C Db</p>				

3.5. North America (USA/Canada)

Approval	Description
	<p>Valid for coils: UL Recognized for the USA and Canada</p> <p>The coils are UL Recognized for the USA and Canada according to:</p> <ul style="list-style-type: none"> • UL 429 (electrically operated valves) • CAN/CSA-C22.2 No. 61010-1
	<p>Valid for coils: UL Hazardous Locations – Explosion Protection</p> <p>UL Listed for Hazardous Locations for USA and Canada</p> <p>Class I, Zone 1 Class I, Division 2, Group A, B, C and D Class II + III, Division 2, Group F and G</p>

DTS 1000602619 EN Version: C Status: RL (released | freigegeben | validé) printed: 20.03.2025

4. Materials

4.1. Bürkert resistApp



Bürkert resistApp – Chemical resistance chart

You want to ensure the reliability and durability of the materials in your individual application case? Verify your combination of media and materials on our website or in our resistApp.

[Start chemical resistance check](#)

4.2. Material specifications

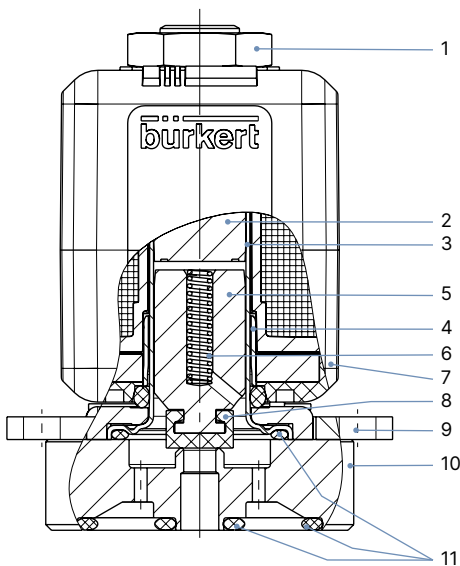

No.	Element	Material
1	Locknut	DIN 176 Thick-film passivated surface KOSA0101
2	Stopper	Stainless steel 1.4113/434
3	Core guide tube	Stainless steel 1.4303 ST/305L
4	Pole sleeve	Stainless steel 1.4016
5	Core	Stainless steel 1.4113/434
6	Spring	Stainless steel 1.4310/301
7	Core seal	EPDM
8	Coil	Epoxy
9	Mounting plate	Stainless steel 1.4404/316L
10	Push-in flange	Stainless steel 1.4404/316L Stainless steel 1.4571/316Ti
11	Seal to the outside	EPDM

5. Dimensions

5.1. Threaded variant

Coil size 24.5 mm (AC08)

Note:

Dimensions in mm [inch]

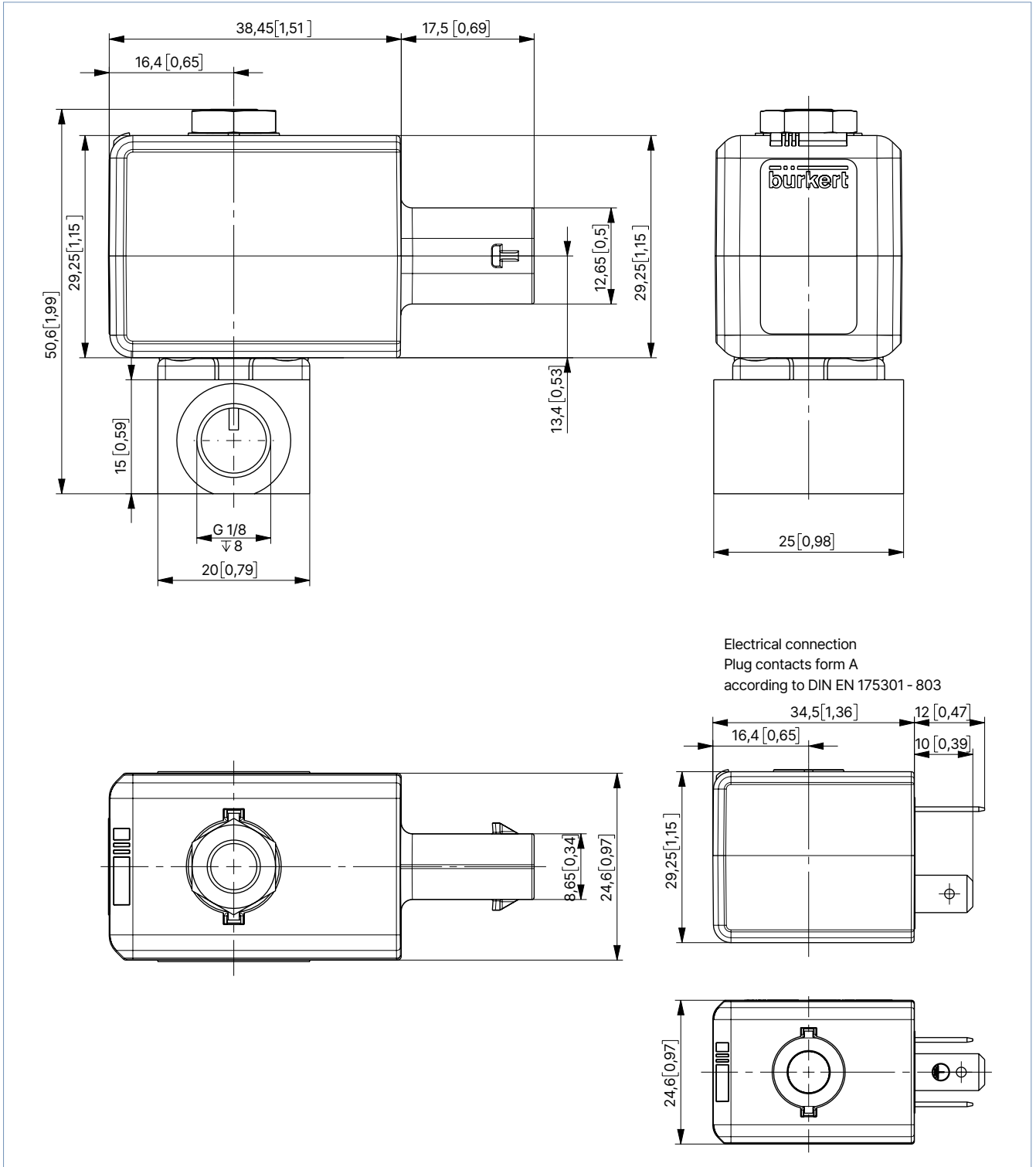

DTS 1000602619 EN Version: C Status: RL (released | freigegeben | validé) printed: 20.03.2025

Coil size 32 mm (AC10)

Note:

Dimensions in mm [inch]

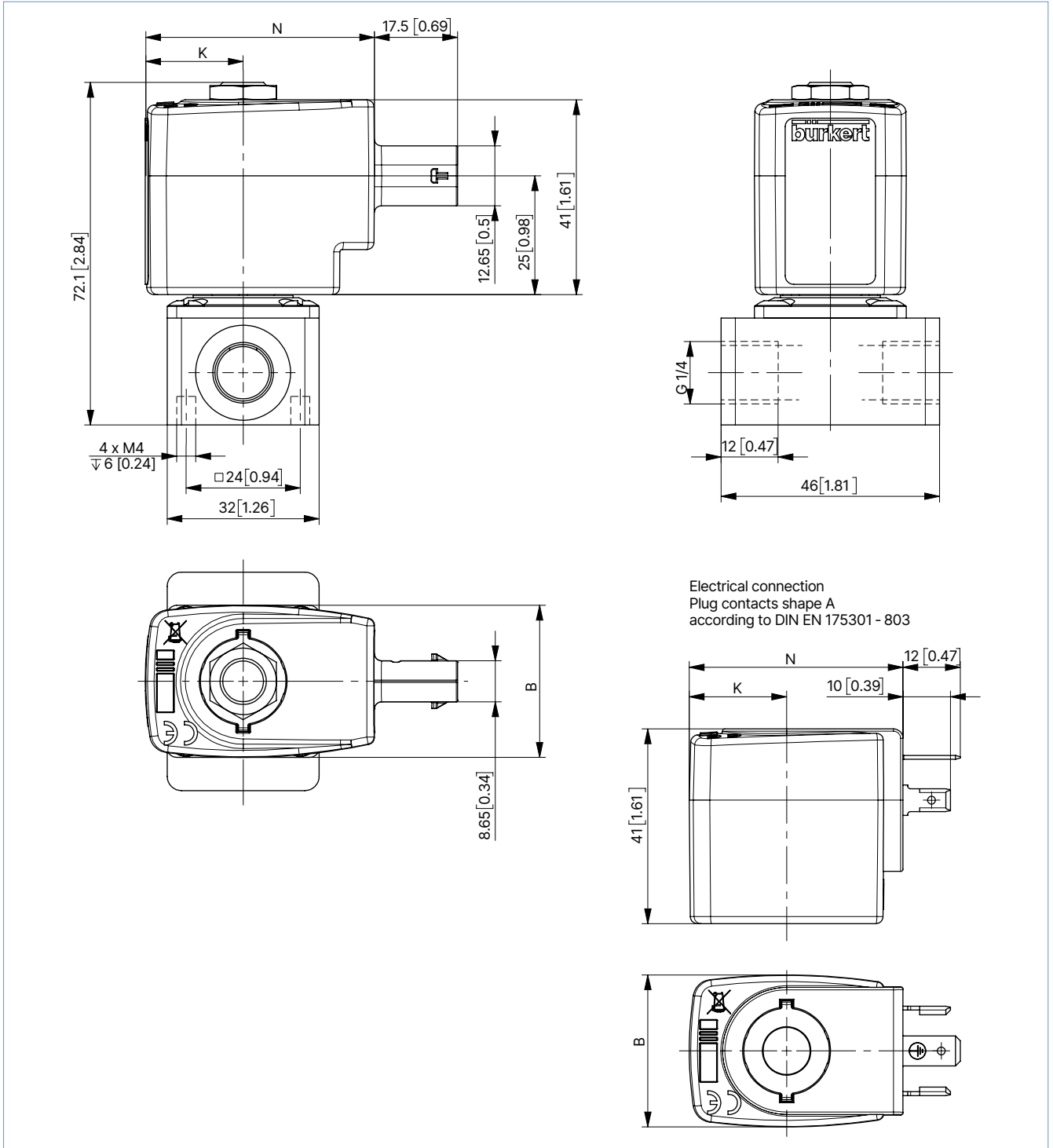

ELA	Electrical connection	SG (coil size)	B		H		K		N	
			[mm]	[inch]	[mm]	[inch]	[mm]	[inch]	[mm]	[inch]
GA	Plug form A according to DIN EN 175301 - 803	5	32	1.26	41	1.61	20.5	0.83	45	1.77
	Plug KOSTAL MLK1.2 / TE MCON 1.2, 2-pin, coding A (male)	6	40	1.57					51	2.08
39	Plug form A according to DIN EN 175301 - 803	5	32	1.26	41	1.61	20.5	0.83	48.3	1.90
	Plug KOSTAL MLK1.2 / TE MCON 1.2, 2-pin, coding A (male)	6	40	1.57					54.2	2.13

5.2. Push-in flange variant

Coil size 24.5 mm (AC08)

Note:

Dimensions in mm [inch]

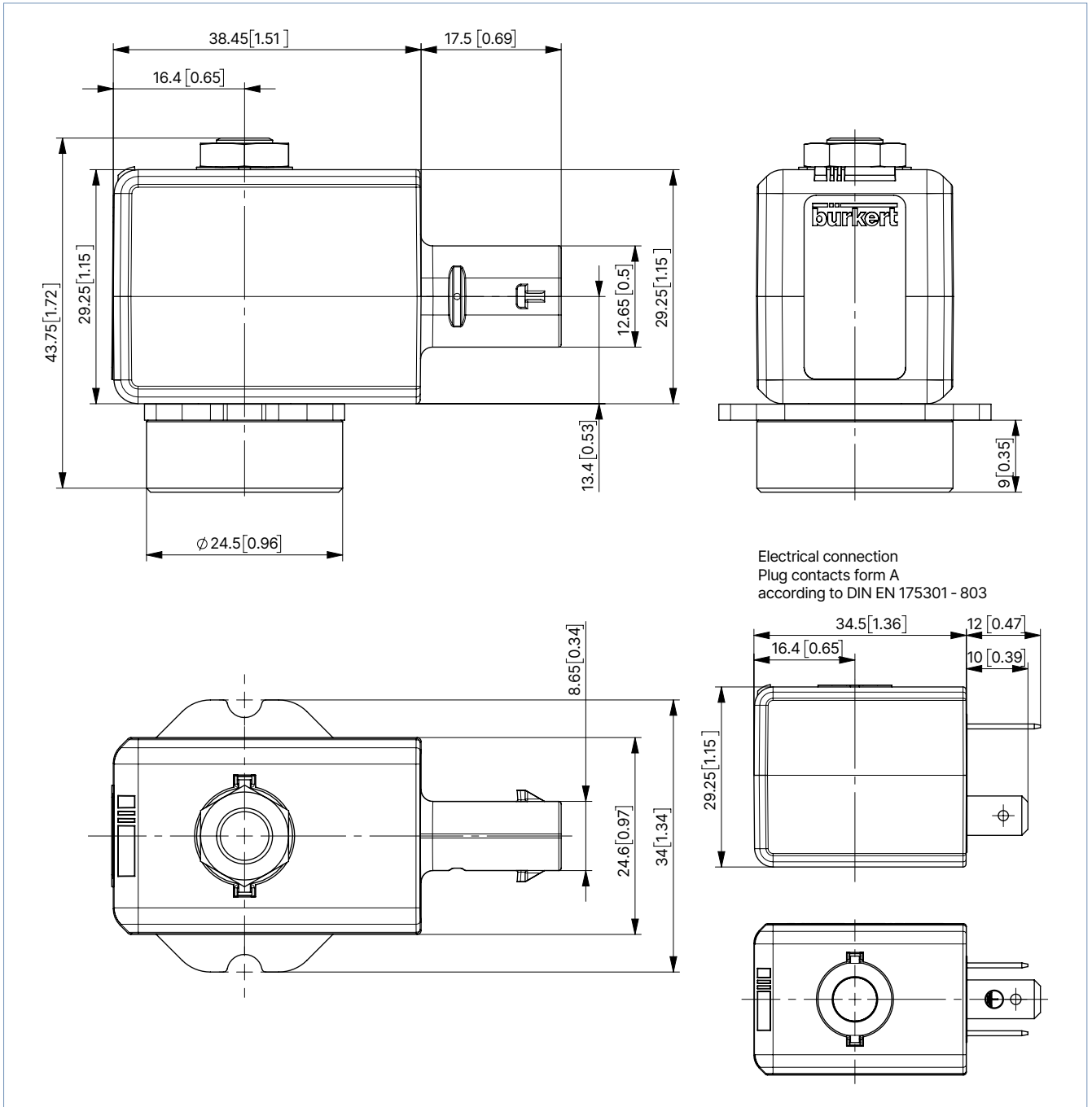

Push-in flange connection diagram coil size 24.5 mm (AC08)

Note:

Dimensions in mm [inch]

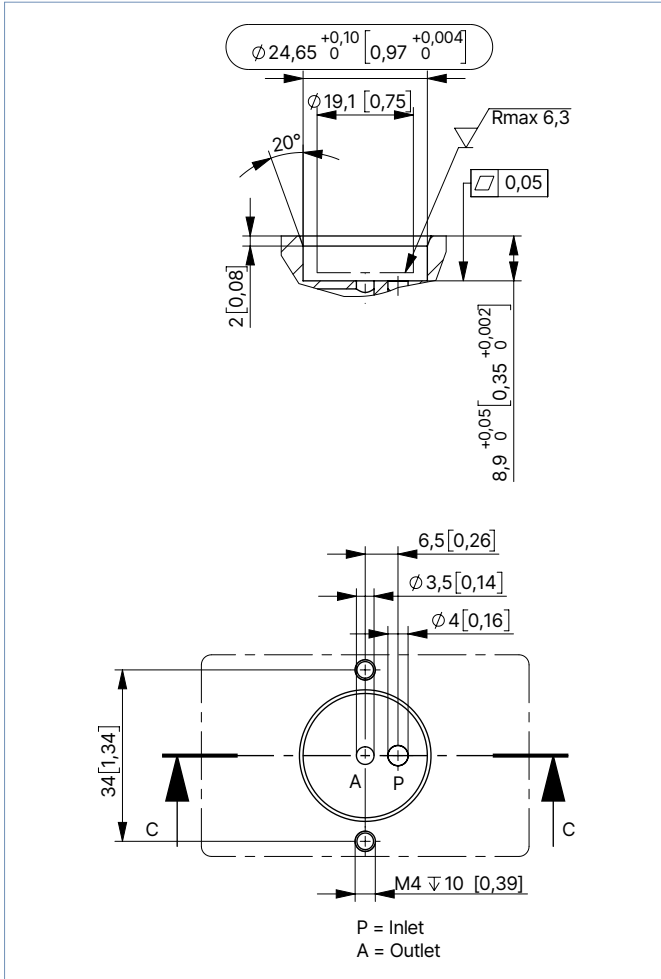

Coil size 32 mm (AC10)

Note:

Dimensions in mm [inch]

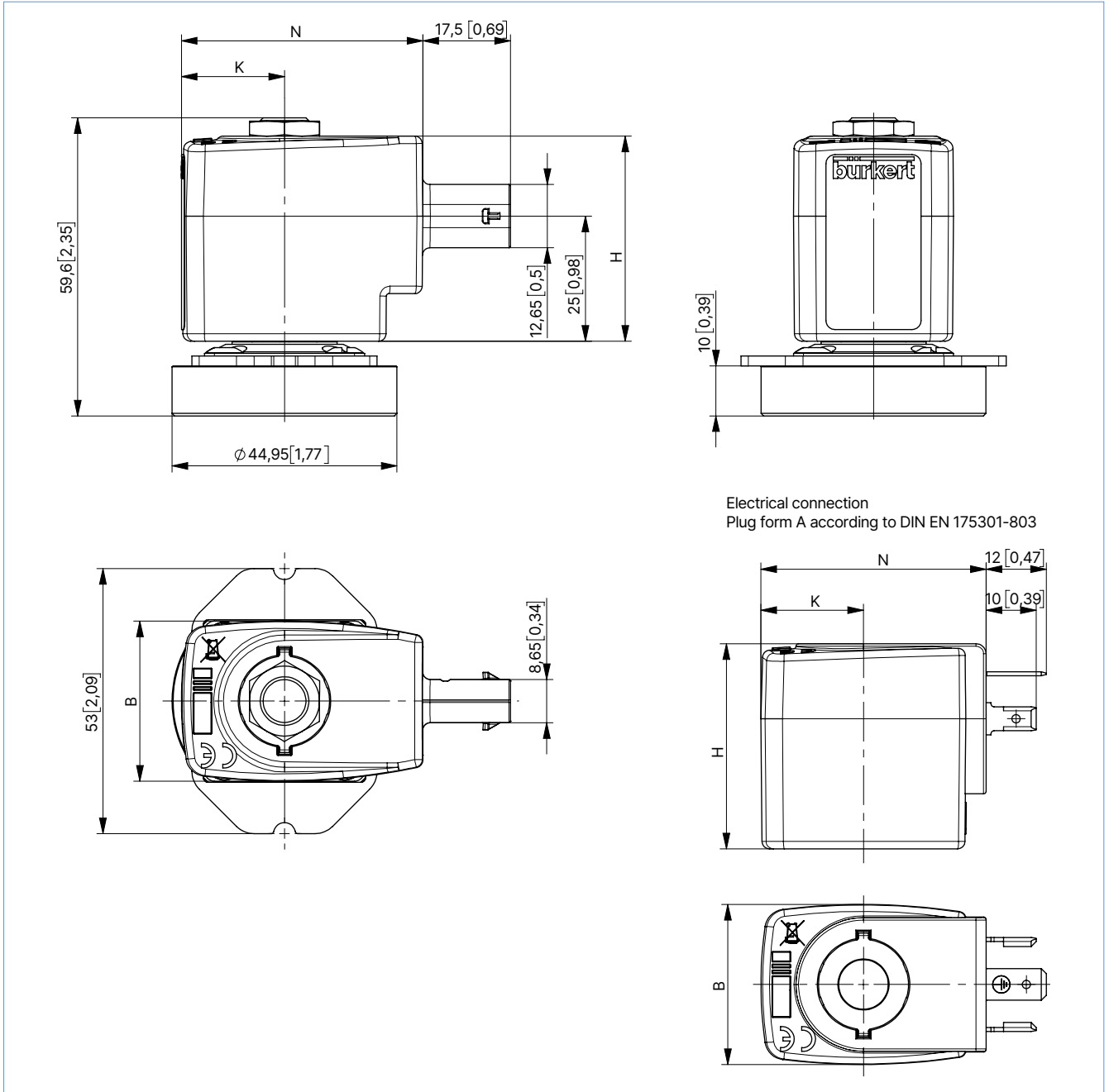

ELA	Electrical connection	SG (coil size)	B		H		K		N	
			[mm]	[inch]	[mm]	[inch]	[mm]	[inch]	[mm]	[inch]
GA	Plug form A according to DIN EN 175301-803	5	32	1.26	41	1.61	20.5	0.83	45	1.77
	Plug KOSTAL MLK1.2 / TE MCON 1.2, 2-pin, coding A (male)	6	40	1.57			27.5	1.06	51	2.08
39	Plug form A according to DIN EN 175301-803	5	32	1.26	41	1.61	20.5	0.83	48.3	1.90
	Plug KOSTAL MLK1.2 / TE MCON 1.2, 2-pin, coding A (male)	6	40	1.57			23.6	1.06	54.2	2.13

DTS 1000602619 EN Version: C Status: RL (released | freigegeben | valide) printed: 20.03.2025

Push-in flange connection diagram coil size 32 mm (AC10)

Note:

Dimensions in mm [inch]

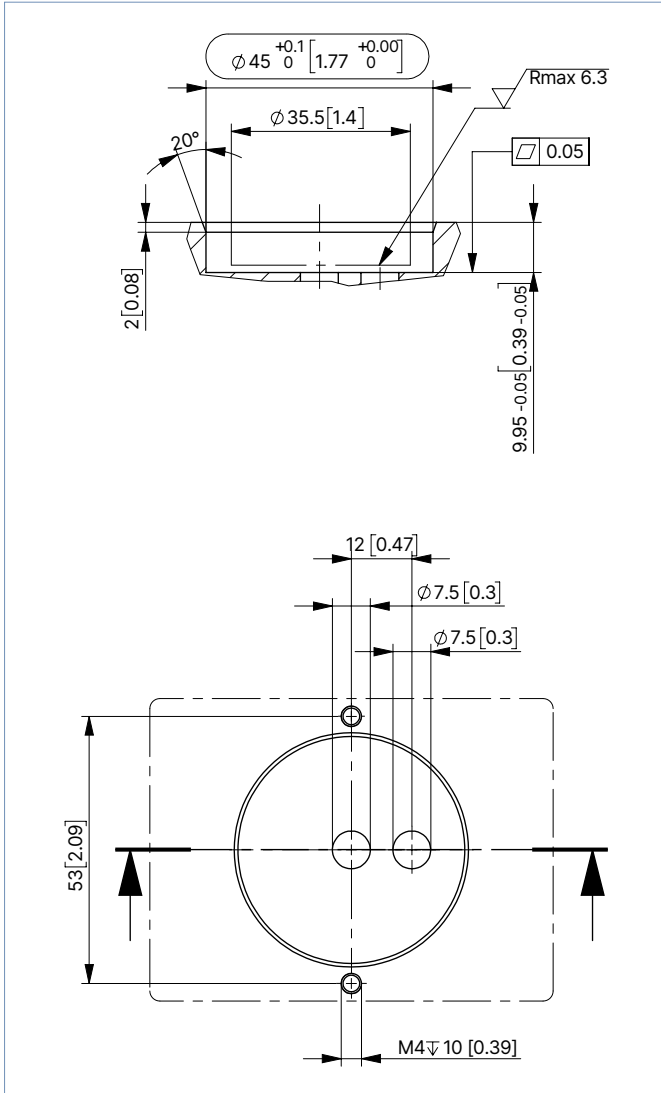

5.3. Flange variant

Coil size 24.5 mm (AC08)

Note:

Dimensions in mm [inch]

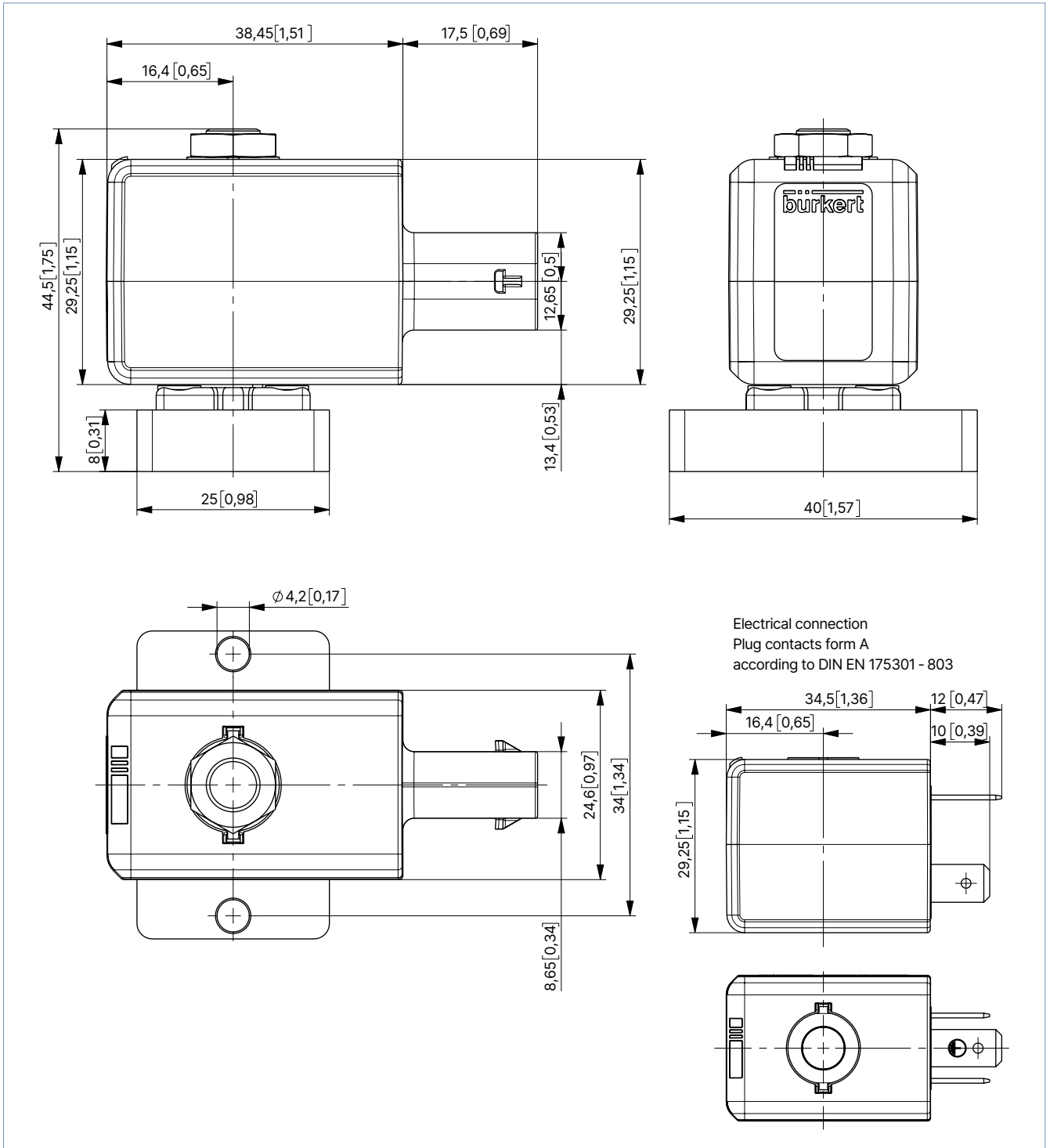

DTS 1000602619 EN Version: C Status: RL (released | freigegeben | valide) printed: 20.03.2025

Flange pattern coil size 24.5 mm (AC08)

Note:

- Dimensions in mm [inch]
- On the connection side, the geometries are to be realised as shown in the following drawing.

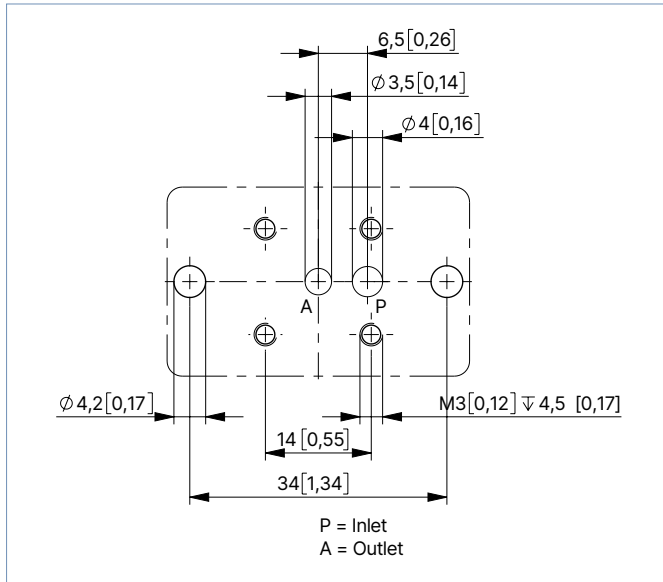

Coil size 32 mm (AC10)

Note:

Dimensions in mm [inch]

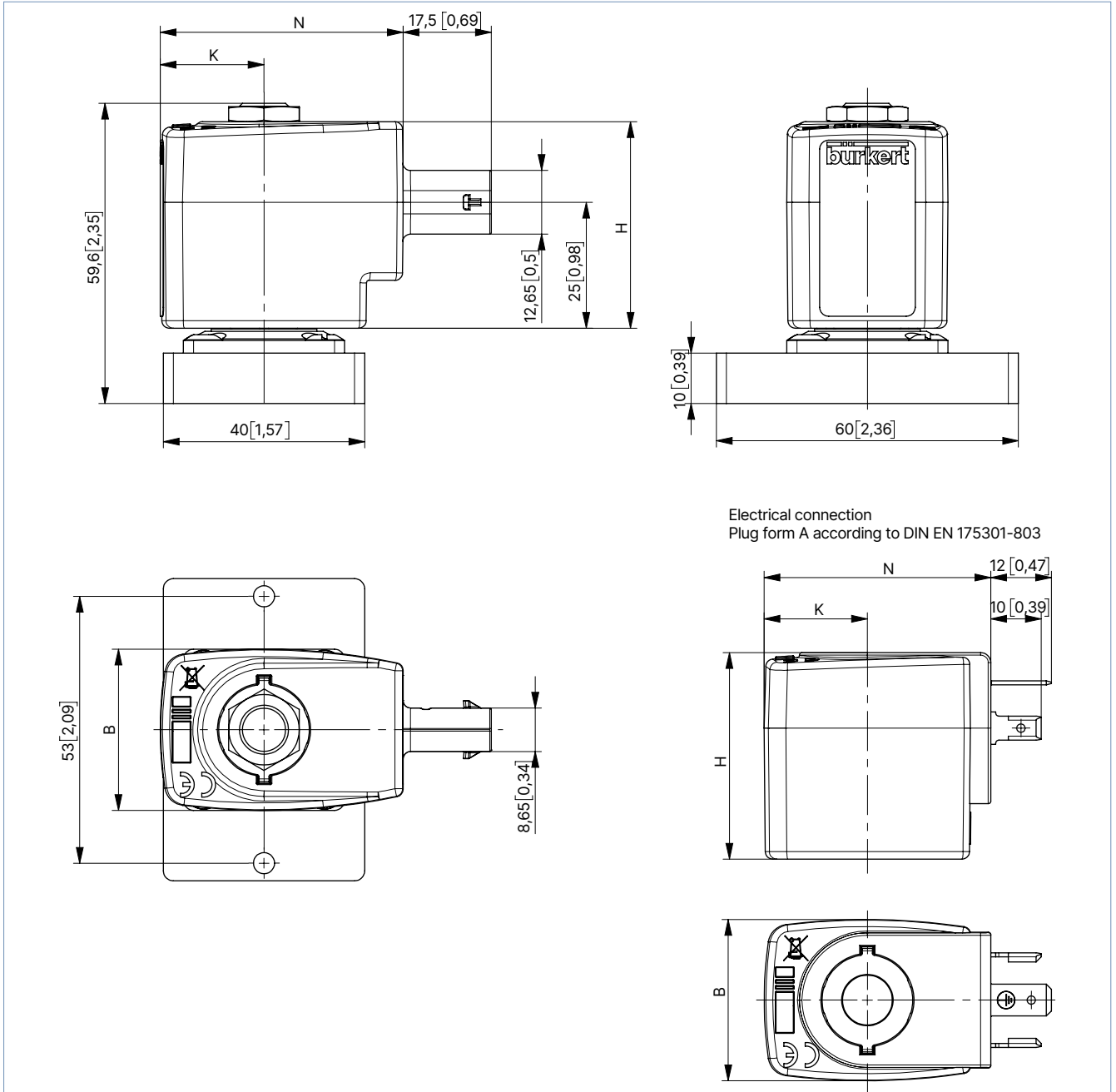

Electrical connection
Plug form A according to DIN EN 175301-803

ELA	Electrical connection	SG (coil size)	B		H		K		N	
			[mm]	[inch]	[mm]	[inch]	[mm]	[inch]	[mm]	[inch]
GA	Plug form A according to DIN EN 175301 - 803	5	32	1.26	41	1.61	20.5	0.83	45	1.77
	Plug KOSTAL MLK1.2 / TE MCON 1.2, 2-pin, coding A (male)	6	40	1.57			27.5	1.06	51	2.08
39	Plug form A according to DIN EN 175301 - 803	5	32	1.26	41	1.61	20.5	0.83	48.3	1.90
	Plug KOSTAL MLK1.2 / TE MCON 1.2, 2-pin, coding A (male)	6	40	1.57			23.6	1.06	54.2	2.13

Flange pattern coil size 32 mm (AC10)**Note:**

- Dimensions in mm [inch]
- On the connection side, the geometries are to be realised as shown in the following drawing.

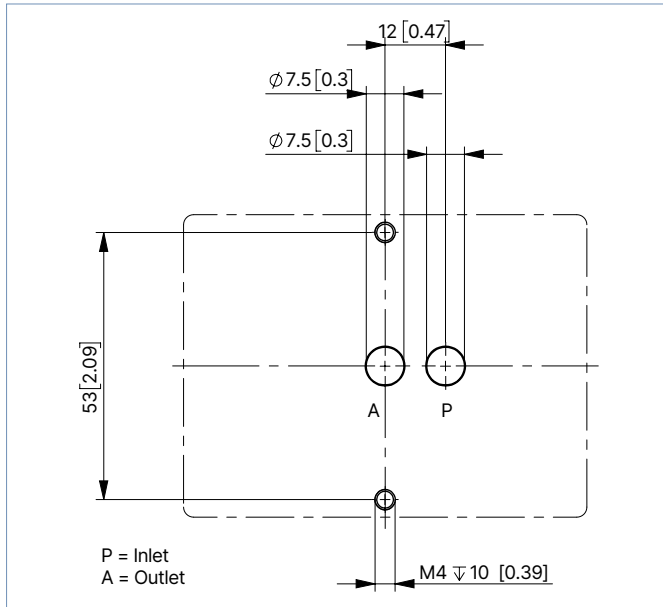

5.4. ATEX/IECEx cable variant

Coil size 24.5 mm (AC08)

Note:

Dimensions in mm [inch]

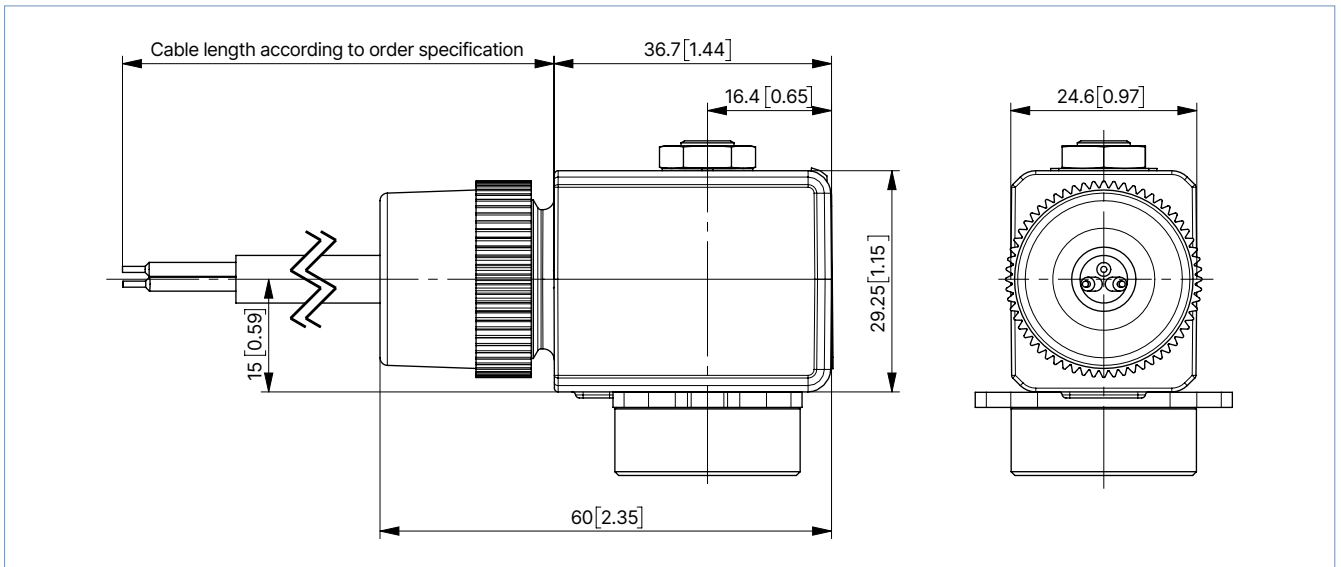

Coil size 40 mm (AC10)

Note:

Dimensions in mm [inch]

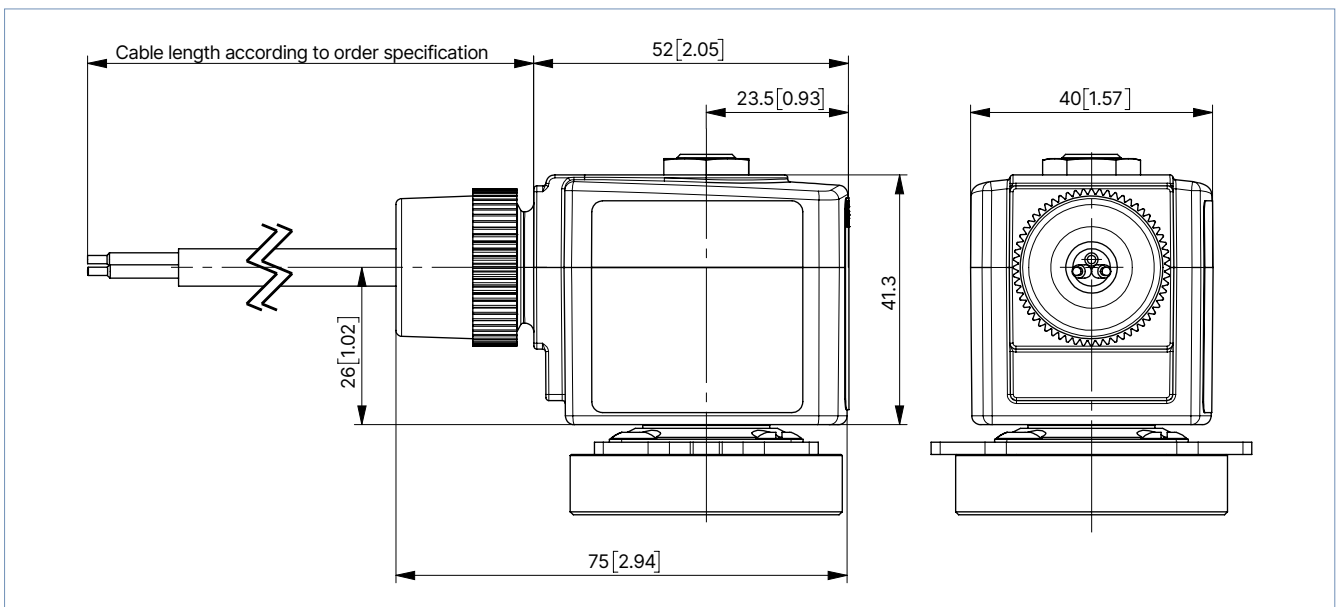

DTS 1000602619 EN Version: C Status: RL (released | freigegeben | validé) printed: 20.03.2025

6. Performance specifications

6.1. Power consumption

Coil	Coil size	Electrical power		Maximum duty cycle	Switching times ¹⁾	
		DC			Opening [ms]	Closing [ms]
	[mm]	Cold [W]	Hot [W]			
24 V/DC/5.5 W	24.5	5.5	4.5	100 % ED	8...15	10...17
24 V/DC/7 W		7	5.5	50 % ED		
24 V/DC/11 W		11	8.5			
24 V/DC/14 W		14	11			
ATEX/IECEx 6 W		6	5	100 % ED		
24 V/DC/9 W	40	9	8	100 % ED	20	30
24 V/DC/17 W		17	13.5	50 % ED		
24 V/DC/36 W		36	28	20 % ED		
ATEX/IECEx 9 W		9	8	100 % ED		



1.) Measurement at + 68 °F, 87 psi at valve outlet, opening: pressure build-up 0...90%, closing: pressure drop 100...10%

7. Product accessories

7.1. Cable glands for ATEX/IECEx terminal box

Note:

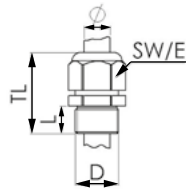
A polyamide cable gland is included in the scope of delivery. A nickel-plated brass variant can be ordered for a surcharge, see [“Cable glands for ATEX/IECEx terminal box” on page 27](#).

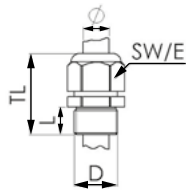
Description	Ex approvals		Dimensions										
	Certification	Identification											
Ex cable gland, Nickel-plated brass, 6...13 mm 	PTB 04 ATEX 1112 X, IECEx PTB 13.0027X	II 2 G Ex e IIC Gb, II 2 D Ex tb IIIC Db IP68	 <table border="1"> <tr><td>TL</td><td>29...37 mm</td></tr> <tr><td>L</td><td>6 mm</td></tr> <tr><td>D</td><td>20 mm</td></tr> <tr><td>SW</td><td>24 mm</td></tr> <tr><td>E</td><td>27 mm</td></tr> </table>	TL	29...37 mm	L	6 mm	D	20 mm	SW	24 mm	E	27 mm
TL	29...37 mm												
L	6 mm												
D	20 mm												
SW	24 mm												
E	27 mm												
Ex cable gland, Polyamide, 7...13 mm 	PTB 13 ATEX 1015 X, IECEx PTB 13.0034X	II 2 G Ex e IIC Gb, II 2 D Ex tb IIIC Db IP68	 <table border="1"> <tr><td>TL</td><td>36...45 mm</td></tr> <tr><td>L</td><td>10 mm</td></tr> <tr><td>D</td><td>20 mm</td></tr> <tr><td>SW</td><td>24 mm</td></tr> <tr><td>E</td><td>28 mm</td></tr> </table>	TL	36...45 mm	L	10 mm	D	20 mm	SW	24 mm	E	28 mm
TL	36...45 mm												
L	10 mm												
D	20 mm												
SW	24 mm												
E	28 mm												

DTS 1000602619 EN Version: C Status: RL (released | freigegeben | validé) printed: 20.03.2025

7.2. Special tool to turn the terminal box

Note:

This special tool is not included in the scope of delivery of the valve, see ["Cable glands for ATEX/IECEX terminal box"](#) on page 27.

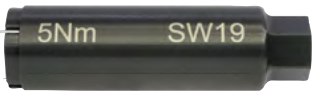
Description	Components of the set
Set SC02-AC10 	<ul style="list-style-type: none"> • Special wrench • Service manual

8. Ordering information

8.1. Bürkert eShop



Bürkert eShop – Easy ordering and quick delivery

You want to find your desired Bürkert product or spare part quickly and order directly? Our online shop is available for you 24/7. Sign up and enjoy all the benefits.

[Order online now](#)

8.2. Bürkert product filter



Bürkert product filter – Get quickly to the right product

You want to select products comfortably based on your technical requirements? Use the Bürkert product filter and find suitable articles for your application quickly and easily.

[Try out our product filter](#)

8.3. Bürkert Product Enquiry Form

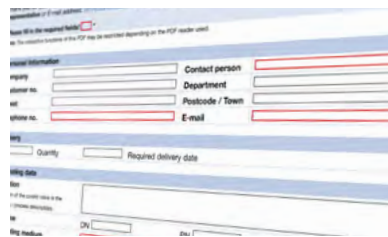

Bürkert Product Enquiry Form – Your enquiry quickly and compactly

Would you like to make a specific product enquiry based on your technical requirements? Use our Product Enquiry Form for this purpose. There you will find all the relevant information for your Bürkert contact. This will enable us to provide you with the best possible advice.

[Fill out the form now](#)

DTS 1000602619 EN Version: C Status: RL (released | freigegeben | validé) printed: 20.03.2025

8.4. Ordering chart

Standard variant with plug form B according to DIN EN 175301 - 803 (IP65 coil)

Note:

- Please note that the cable plug Type 2507 is included. Further information can be found in chapter [“Cable plug Type 2507, form B according to industry standard” on page 26](#) or separate data sheet for **Type 2507** ▶.
- Other variants with alternative voltages, G or RC internal thread are available on request.

Circuit function	Port connection	Orifice	C _v value water ¹⁾	Maximum duty cycle	Coil power	Pressure range (MAWP ²⁾)		Article no.		
						Ambient temperature 167 °F	Ambient temperature 131 °F			
		[mm]	[gal/min]			[W]	[psi]	[psi]	[V/Hz]	
Stainless steel body, seal material EPDM/EPDM										
CF A 2/2-way solenoid valve Direct-acting Normally closed 	Threaded housing with internal G thread									
	G 1/8	1.0	0.04	100 % ED	7	–	0...435	20111751		
				50 % ED ³⁾	5.5	0...232	–	o. r.		
				11	0...435	–	20111752			
		1.6	0.07	100 % ED	7	–	0...174	20111754		
				50 % ED ³⁾	5.5	0...131	–	o. r.		
				14	–	0...363	–	o. r.		
		11	0...290	–	20111755					
						11	0...290	–	20111755	
						11	0...290	–	20111755	
		2.0	0.13	100 % ED	7	–	0...131	20107242		
				50 % ED ³⁾	5.5	0...94	–	o. r.		
				14	–	0...276	–	o. r.		
	11	0...203	–	20111756						
					11	0...203	–	20111756		
					11	0...203	–	20111756		
	2.4	0.15	100 % ED	7	–	0...51	20111757			
			50 % ED ³⁾	5.5	0...44	–	o. r.			
			14	–	0...131	–	o. r.			
	11	0...94	–	20106668						
					11	0...94	–	20106668		
					11	0...94	–	20106668		
	Push-in flange housing									
	FC22	1.0	0.04	100 % ED	7	–	0...290	o. r.		
				50 % ED ³⁾	5.5	0...232	–	20069830		
				11	0...290	–	o. r.			
				1.6	0.09	100 % ED	7	–	0...174	o. r.
						50 % ED ³⁾	5.5	0...131	–	20069717
11						0...290	–	o. r.		
2.0		0.14	100 % ED	7	–	0...131	o. r.			
			50 % ED ³⁾	5.5	0...94	–	20114143			
			14	–	0...276	–	o. r.			
11		0...203	–	o. r.						
					11	0...203	–	o. r.		
					11	0...203	–	o. r.		
2.4		0.16	100 % ED	7	–	0...51	o. r.			
			50 % ED ³⁾	5.5	0...44	–	20114144			
			14	–	0...131	–	o. r.			
11		0...94	–	20069721						
					11	0...94	–	20069721		
					11	0...94	–	20069721		
3.0	0.25	100 % ED	7	–	0...22	o. r.				
		50 % ED ³⁾	5.5	0...73	–	20114145				
		14	–	0...65	–	o. r.				
11	0...44	–	o. r.							
				11	0...44	–	o. r.			

DTS 1000602619 EN Version: C Status: RL (released | freigegeben | valide) printed: 20.03.2025

Circuit function	Port connection	Orifice [mm]	C _v value water ^{1.)} [gal/min]	Maximum duty cycle	Coil power [W]	Pressure range (MAWP ^{2.)}		Article no. 024/DC [V/Hz]	
						Ambient temperature 167 °F [psi]	Ambient temperature 131 °F [psi]		
CF A 2/2-way solenoid valve Direct-acting Normally closed 	Flange housing								
	FK18	1.0	0.04	100 % ED	7	–	0...435	o. r.	
					5.5	0...232	–	o. r.	
					11	0...435	–	o. r.	
		1.6	0.09	100 % ED	7	–	0...174	o. r.	
					5.5	0...131	–	o. r.	
					14	–	0...363	o. r.	
		2.0	0.14	100 % ED	7	–	0...131	o. r.	
					5.5	0...94	–	o. r.	
					14	–	0...276	o. r.	
		2.4	0.16	100 % ED	7	–	0...51	o. r.	
					5.5	0...44	–	o. r.	
					14	–	0...131	o. r.	
		3.0	0.25	100 % ED	7	–	0...22	o. r.	
					5.5	0...73	–	o. r.	
					14	–	0...65	o. r.	
						11	0...44	–	o. r.
						11	0...290	–	o. r.
						11	0...203	–	o. r.
						11	0...94	–	20071781

o. r. = on request

1.) Flow coefficient at + 60 °F and pressure drop of 1 psi

2.) Maximum allowable working pressure

3.) For 100 % ED, the power must be reduced by means of current control or PWM signal to max. 50 % (holding phase) after max. 500 ms (switch-on pulse).

Standard variant with plug form A according to DIN EN 175301 - 803 (IP65 coil)

Note:

- Please note that the cable plug Type 2507 is included. Further information can be found in chapter “Cable plug Type 2518, form A according to DIN EN 175301 - 803” on page 27 or separate data sheet for **Type 2518** ▶.
- Other variants with alternative voltages, G or RC internal thread are available on request.

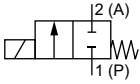
Circuit function	Port connection	Orifice [mm]	C _v value water ^{1.)} [gal/min]	Maximum duty cycle	Coil power [W]	Pressure range (MAWP ^{2.)}		Article no. 024/DC [V/Hz]
						Ambient temperature 167 °F [psi]	Ambient temperature 131 °F [psi]	
Stainless steel body, seal material EPDM/EPDM								
CF A 2/2-way solenoid valve Direct-acting Normally closed 	Threaded housing with internal G thread							
	G ¼	2.0	0.14	100 % ED	9	–	0...174	20114146
				50 % ED ^{3.)}	17	0...189	–	20114147
		3.0	0.25	100 % ED	9	–	0...87	20114148
				50 % ED ^{3.)}	17	0...65	–	20114149
		4.0	0.35	100 % ED	9	–	0...22	20114150
				50 % ED ^{3.)}	17	0...22	–	20095341
	6.0	0.64	100 % ED	9	–	0...7	20114151	
			20 % ED ^{4.)}	36	0...15	–	20114152	
	Push-in flange housing							
	FC23	3.0	0.25	100 % ED	9	–	0...73	o. r.
				50 % ED ^{3.)}	17	0...65	–	20114153
		4.0	0.52	100 % ED	9	–	0...22	o. r.
				50 % ED ^{3.)}	17	0...22	–	20095344
		6.0	0.69	100 % ED	9	–	0...7	o. r.
				20 % ED ^{4.)}	36	0...15	–	20095163
	Flange housing							
	FK19	2.0	0.14	100 % ED	9	–	0...174	o. r.
				50 % ED ^{3.)}	17	0...189	–	o. r.
		3.0	0.25	100 % ED	9	–	0...87	o. r.
				50 % ED ^{3.)}	17	0...65	–	o. r.
		4.0	0.52	100 % ED	9	–	0...22	o. r.
				50 % ED ^{3.)}	17	0...22	–	20095346
	6.0	0.69	100 % ED	9	–	0...7	o. r.	
20 % ED ^{4.)}			36	0...15	–	o. r.		

o. r. = on request

1.) Flow coefficient at + 60 °F and pressure drop of 1 psi

2.) Maximum allowable working pressure

3.) For 100 % ED, the power must be reduced by means of current control or PWM signal to max. 50 % (holding phase) after max. 500 ms (switch-on pulse).

4.) For 100 % ED, the power must be reduced by means of current control or PWM signal to max. 33 % (holding phase) after max. 500 ms (switch-on pulse).

DTS 1000602619 EN Version: C Status: RL (released) | freigegeben | valide | printed: 20.03.2025

Variant with automotive plug (IP6K9K coil)

Note:

- Depending on the variant, a power reduction by means of current control or PWM signal to 50 % of the nominal power (holding phase) may be necessary after max. 500 ms (switch-on pulse).
- The variants are designed for an increased voltage tolerance of -25%/+30%.
- Other variants with alternative voltages, G or RC internal thread are available on request.

Circuit function	Port connection	Orifice	C _v value water ^{1.)}	Maximum duty cycle	Coil power	Pressure range (MAWP ^{2.)})		Article no.				
						Ambient temperature 185 °F	012/DC	024/DC				
									[W]	[psi]	[V/Hz]	[V/Hz]
		[mm]	[gal/min]									
Stainless steel body, seal material EPDM/EPDM												
CF A												
2/2-way solenoid valve Direct-acting Normally closed 	Threaded housing with internal G thread											
	G 1/8	1.0	0.04	100 % ED	5.5	0...261	o. r.	20111758				
		1.6	0.07			0...87			20111759			
		2.0	0.13			0...58			20097055			
		2.4	0.15			50 % ED ^{3.)}			11	0...94	20095160	
	G 1/4	2.0	0.14	50 % ED ^{3.)}	17	0...189	o. r.	20114154				
		3.0	0.25			0...65			20114155			
		4.0	0.35			0...22			20095162			
		6.0	0.64			20 % ED ^{4.)}			36	0...15	20114156	
	Push-in flange housing											
	FC22	1.0	0.04	100 % ED	5.5	0...261	o. r.	20069951				
		1.6	0.09			0...87			20069723			
		2.0	0.14			0...58			20114157			
		2.4	0.16			50 % ED ^{3.)}			11	0...94	20099747	20069725
		3.0	0.25			0...29			o. r.	20085132		
	FC23	3.0	0.25	50 % ED ^{3.)}	17	0...65	o. r.	20102954				
		4.0	0.52			0...22			20079373			
		6.0	0.69			20 % ED ^{4.)}			36	0...15	20085133	
	Flange housing											
	FK18	1.0	0.04	100 % ED	5.5	0...261	o. r.	o. r.				
1.6		0.09	0...87			o. r.						
2.0		0.14	0...58			o. r.						
2.4		0.16	50 % ED ^{3.)}			11			0...94	o. r.	20085130	
3.0		0.25	0...29			o. r.			20087659			
FK19	2.0	0.14	50 % ED ^{3.)}	17	0...189	o. r.	o. r.					
	3.0	0.25			0...65			20102949				
	4.0	0.52			0...22			20079374				
	6.0	0.69			20 % ED ^{4.)}			36	0...15	20087655		

o. r. = on request

1.) Flow coefficient at +60 °F and pressure drop of 1 psi

2.) Maximum allowable working pressure

3.) For 100 % ED, the power must be reduced by means of current control or PWM signal to max. 50 % (holding phase) after max. 500 ms (switch-on pulse).

4.) For 100 % ED, the power must be reduced by means of current control or PWM signal to max. 33 % (holding phase) after max. 500 ms (switch-on pulse).

DTS 1000602619 EN Version: C Status: RL (released | freigegeben | valide) printed: 20.03.2025

Coil to be UL Listed for hazardous locations, Class I, Division 2

Note:

- In the standard variant, the cable length is 3 m. Other lengths are available on request.
- Other variants with alternative voltages, G or RC internal thread are available on request.
- Variants with terminal box are available for NPT ¼, FC23 and FK19 on request.

Circuit function	Port connection	Orifice	C _v value water ^{1.)}	Maximum duty cycle	Coil power	Pressure range (MAWP ^{2.)})	Article no.	
		[mm]	[gal/min]			Ambient temperature 131 °F		[psi]
Stainless steel body, seal material EPDM/EPDM								
CF A 2/2-way solenoid valve Direct-acting Normally closed 	Threaded housing with internal G thread							
	G ⅛	1.0	0.04	100 % ED	6	0...232	o. r.	
		1.6	0.07			0...145	o. r.	
		2.0	0.13			0...102	o. r.	
		2.4	0.15			0...51	o. r.	
	G ¼	2.0	0.14	100 % ED	9	0...145	o. r.	
		3.0	0.25			0...73	o. r.	
		4.0	0.35			0...17	o. r.	
		6.0	0.64			0...6	o. r.	
	Push-in flange housing							
	FC22	1.0	0.04	100 % ED	6	0...232	o. r.	
		1.6	0.09			0...145	o. r.	
		2.0	0.14			0...102	o. r.	
		2.4	0.16			0...51	o. r.	
		3.0	0.25			0...14	o. r.	
	FC23	3.0	0.25	100 % ED	9	0...73	o. r.	
		4.0	0.52			0...17	o. r.	
		6.0	0.69			0...6	o. r.	
	Flange housing							
	FK18	1.0	0.04	100 % ED	6	0...232	o. r.	
		1.6	0.09			0...145	o. r.	
		2.0	0.14			0...102	o. r.	
		2.4	0.16			0...51	o. r.	
		3.0	0.25			0...14	o. r.	
FK19	2.0	0.14	100 % ED	9	0...145	o. r.		
	3.0	0.25			0...73	o. r.		
	4.0	0.52			0...17	o. r.		
	6.0	0.69			0...6	o. r.		

o. r. = on request

1.) Flow coefficient at + 60 °F and pressure drop of 1 psi

2.) Maximum allowable working pressure

DTS 1000602619 EN Version: C Status: RL (released | freigegeben | validé) printed: 20.03.2025

8.5. Ordering chart accessories

Cable plug Type 2507, form B according to industry standard

Note:

- Dimensions in mm
- Delivery of cable plug includes a flat seal and a fixing screw.
- Refer to data sheet **Type 2507** ▶ for more information about the cable plug.

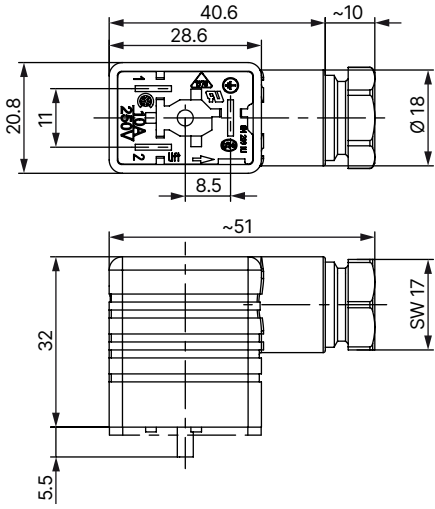
Cable plug	Dimensions	Variant	Voltage	Article no.
		Without circuitry (standard)	2...250 V AC/DC	423845
		With LED	24 V AC/DC	423849
		With LED and free-wheeling diode	12...24 V AC/DC	423851
		With rectifier, LED and varistor	12...24 V AC/DC	423853

Cable plug Type 2516, form C according to DIN EN 175301 - 803

Note:

- Dimensions in mm
- Delivery of cable plug includes a flat seal and a fixing screw.
- For further variants see data sheet **Type 2516** ▶.

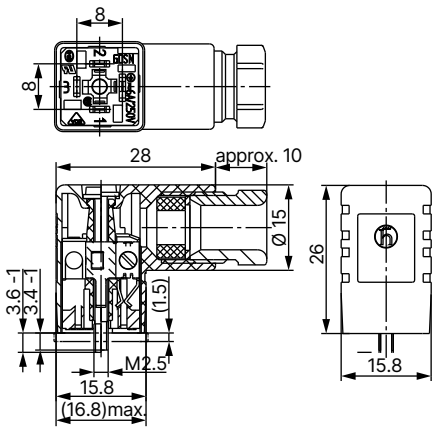
Cable plug	Dimensions	Variant	Voltage	Article no.
		Without circuitry	0...250 V AC/DC	303141
		With LED	12...24 V AC/DC	303145
		With LED and varistor	12...24 V AC/DC	303148
		With rectifier, LED and varistor	12...24 V AC/DC	303142

DTS 1000602619 EN Version: C Status: RL (released | freigegeben | valide) printed: 20.03.2025

Cable plug Type 2518, form A according to DIN EN 175301 - 803

Note:

- Dimensions in mm
- For further variants see data sheet **Type 2518** ▶

Cable plug	Dimensions	Variant	Voltage	Article no.
		Without circuitry (AC/DC)	0...250 V AC/DC	314802 𐀀
		With LED (AC/DC)	12...24 V AC/DC	314812 𐀀
		With LED and varistor (AC/DC)	12...24 V AC/DC	314820 𐀀
		With rectifier, LED and varistor	12...24 V AC/DC	314816 𐀀
		Without circuitry (AC/DC) with silicone seal for higher ambient temperature, e.g. steam variant (NA07)	0...250 V AC/DC	361687 𐀀

Cable plug Type 2509, form A according to DIN EN 175301 - 803

Note:

- Dimensions in mm
- Without circuitry (standard)
- The cable plug meets the requirements for UL hazloc Div. 2.
- The cable plug Type 2509 meets the requirements in accordance with UL Listed (UL 429) in assembly with a Bürkert solenoid valve.
- Refer to data sheet **Type 2509** ▶ for more information about the cable plug.

Cable plug	Dimensions	Variant	Voltage	Article no.
		Without circuitry	0...250 V AC/DC	137943 𐀀

Cable glands for ATEX/IECEx terminal box

Note:

- A cable gland in polyamide variant is included in the delivery. A nickel-plated brass variant can be ordered at surcharge.
- Refer to **"7.1. Cable glands for ATEX/IECEx terminal box"** on page 19 for more information about Ex cable glands.
- Refer to **"7.2. Special tool to turn the terminal box"** on page 20 for more information about the special wrench.

Description	Article no.
Ex cable gland, nickel-plated brass, 6...13 mm ¹⁾	773278 𐀀
Ex cable gland, polyamide, 7...13 mm ¹⁾	773277 𐀀
Set SC02-AC10: special wrench ²⁾ incl. service manual	293488 𐀀

1.) Cable diameter

2.) Not included in the scope of delivery of the valve