





Servo-assisted 2/2-way piston valve

- Servo-assisted piston valve with an orifice up to DN 50
- Explosion proof variant for Cat. 2
- Suitable for gas and steam applications up to + 180 °C
- Relief valves for compressors
- Energy-saving double coil technology with kick and drop variant



Product variants described in the data sheet may differ from the product presentation and description.

Can be combined with

	<p>Type 2518 Cable plug, form A according to DIN EN 175301 - 803</p>	▶
	<p>Type 2509 Cable plug, form A according to DIN EN 175301 - 803</p>	▶

Type description

The 5404 valve is a servo-assisted piston valve available in NC and NO variant. A minimum differential pressure is required for the valve switching function. The solenoid coils are moulded with high-quality epoxy resin. To reduce power consumption in operation, coils with "Kick and Drop" (KD) electronics assembly (double coil technology) are available. In combination with a plug to DIN EN 175301 - 803 Form A, the valves satisfy degree of protection IP65. The cable plug is not included and must be ordered separately.

Table of contents

1. General technical data	4
2. Circuit functions	5
3. Approvals and conformities	5
3.1. General notes	5
3.2. Conformity	5
3.3. Standards	5
3.4. Explosion protection.....	6
3.5. North America (USA/Canada)	6
3.6. Others	7
Oxygen	7
4. Materials	7
4.1. Bürkert resistApp	7
4.2. Material specifications standard variant.....	7
DN 12, circuit function A	7
DN 25, circuit function B.....	8
DN 32, circuit function A	8
4.3. Material specifications steam variant NA07	9
DN 13, circuit function A	9
DN 32, circuit function A, flange body.....	9
4.4. Material specifications high pressure variant PN 08.....	10
DN 12, circuit function A	10
4.5. Material specifications discharge valve for compressor systems CF05.....	10
DN 12, circuit function B	10
5. Dimensions	11
5.1. Standard variant.....	11
Threaded variant DN 12.....	11
Threaded variant DN 20 and DN 25.....	12
Threaded variant DN 32 and DN 50.....	13
5.2. Steam variant NA07	14
Threaded variant DN 13.....	14
Threaded variant DN 20 and DN 25.....	15
Flange variant DN 25.....	16
Threaded variant DN 32 and DN 40	17
Flange variant DN 32 and DN 40.....	18
5.3. High pressure variant up to 1160 psi (PN 08)	19
5.4. Discharge valve for compressor systems CF05	20
Plug variant with ventilation.....	20
5.5. Coil UL Listed for hazardous locations, Class I, Division 2.....	21
6. Performance specifications	22
6.1. Temperature/duty cycle derating diagram for steam variant NA07.....	22
6.2. Characteristic values of intermittent operation.....	22
7. Product accessories	23
7.1. Special tool to turn the terminal box	23

8. Ordering information	23
8.1. Bürkert eShop	23
8.2. Bürkert product filter	23
8.3. Bürkert Product Enquiry Form	23
8.4. Ordering chart	24
Standard variant DN 12...DN 25, UL Recognized and CSA certified	24
Standard variant DN 32...DN 50, UL Recognized and CSA certified	24
Standard variant DN 12...DN 25, UL Listed and CSA certified	25
Standard variant DN 32...DN 50, UL Listed and CSA certified	25
Steam variant NA07, DN 13...DN 40, UL Recognized with coil UL Recognized (cURus)	26
Steam variant NA07, DN 13...DN 40, UL Listed with coil UL Recognized (cURus)	26
Fire Protection service valve, UL Recognized with Fire Protection / UL Listed with Fire Protection.....	27
High pressure variant up to 1160 psi (PN 08), coil UL Recognized (cURus)	27
Discharge valve for compressor systems (CF05), UL Recognized and CSA certified	28
Discharge valve for compressor systems (CF05), UL Listed and CSA certified.....	28
Coil UL Listed (cULus) for hazardous locations, Class I, Division 2 cable variant.....	29
Coil UL Listed (cULus) for hazardous locations, Class I, Division 2 terminal box variant	30
8.5. Ordering chart accessories.....	31
Cable plug Type 2509, form A according to DIN EN 175301 - 803.....	31
Cable plug Type 2518, form A according to DIN EN 175301 - 803	31
Special tool to turn the terminal box	31

DTS 1000582645 EN Version: F Status: RL (released | freigegeben | valide) printed: 15.01.2026

1. General technical data

Product properties	
Dimensions	Further information can be found in chapter “5. Dimensions” on page 11.
Material	
Seal	PTFE seat seal and FKM PTFE seat seal and Graphite (steam variant) PTFE seat seal and EPDM (on request)
Body	Brass
Coil	Epoxy resin (polyamide on request)
Valve inner parts	Stainless steel, brass
Orifice	DN 12...DN 50
Circuit function	A and B Further information can be found in chapter “2. Circuit functions” on page 5.
Thermal insulation class of solenoid coil	Epoxy resin coil class H (class B on request)
Performance data	
Duty cycle	100 % continuous operation
Switching time	
DN 12...DN 25	Opening: 20...400 ms Closing: 100...1500 ms
DN 32...DN 50	Opening: 200...1500 ms Closing: 1000...3000 ms
Electrical data	
Operating voltage	24 V DC, 24 V 50 Hz, 24 V 60 Hz, 110 V 50 Hz, 120 V 60 Hz, 230 V 50 Hz, 240 V 60 Hz (further voltages on request)
Power consumption	
Circuit function A, DN 12...DN 25 (not in combination with high pressure PN 08)	Inrush AC: 24 VA Hold AC (warm coil): 14 VA/8 W Hold DC (warm/cold coil): 8/9.5 W
Circuit function B, DN 12...DN 25	Inrush AC: 24 VA Hold AC (warm coil): 14 VA/8 W Hold DC (warm/cold coil): 8/9.5 W
Explosion-proof variant	Inrush AC: 9 VA Hold AC (warm coil): 9 VA Hold DC (warm/cold coil): 9 W
Circuit function A, DN 32...DN 50 and DN 12 as high pressure PN 08	Inrush AC: 24 VA Hold AC (warm coil): 16 VA/10 W Hold DC (warm/cold coil): 12/13 W
Voltage tolerance	± 10 %
Medium data	
Operating medium	Neutral gases and liquids (e.g. compressed air, water, hydraulic oil and steam)
Medium temperature	
Standard variant	+ 14 °F...+ 248 °F (from - 40 °F on request)
Steam variant	+ 302 °F (at max. ambient temp. + 131 °F) + 320 °F (at max. ambient temp. + 113 °F) “6.1. Temperature/duty cycle derating diagram for steam variant NA07” on page 22
Viscosity	Max. 21 cSt
Product connections	
Electrical connection	Plug contacts according to DIN EN 175 301 - 803 form A for cable plug Type 2518 ▶ . Further information can be found in chapter “Cable plug Type 2518, form A according to DIN EN 175301 - 803” on page 31. Plug contacts according to DIN EN 175 301 - 803 form A for cable plug Type 2509 ▶ . Further information can be found in chapter “Cable plug Type 2509, form A according to DIN EN 175301 - 803” on page 31.
Port connection	G ½, G ¾, G 1, G 1 ¼, G 1 ½, G 2 NPT ½, NPT ¾, NPT 1, NPT 1 ¼, NPT 1 ½, NPT 2

Approvals and conformities

Degree of protection	IP65 with cable plug Type 2518 ▶ (IP67 on request) NEMA 4X with cable plug Type 2509 ▶ with stainless steel screws and epoxy coil
Explosion protection	Further information can be found in chapter "3.4. Explosion protection" on page 6.
North America (USA/Canada)	Further information can be found in chapter "3.5. North America (USA/Canada)" on page 6.
Others	Further information can be found in chapter "3.6. Others" on page 7.

Environment and installation

Installation position	As required, preferably with actuator upright
-----------------------	---

Ambient temperature		
Standard variant	+ 14 °F...+ 131 °F (- 40 °F on request)	
Variant with Kick and Drop coil	30 switching cycles/min	1 switching cycle/min
12/0.6 W	Max. + 158 °F	Max. + 185 °F
20/2.0 W	Max. + 158 °F	Max. + 185 °F
65/7.0 W	Max. + 131 °F	Max. + 158 °F

2. Circuit functions

Symbol	Description
	Circuit function A (CF A) 2/2-way solenoid valve Servo-controlled Normally closed
	Circuit function B (CF B) 2/2-way solenoid valve Servo-controlled Normally open

3. Approvals and conformities

3.1. General notes

- The approvals and conformities listed below must be stated when making enquiries. This is the only way to ensure that the product complies with all required specifications.
- Not all available versions can be supplied with the below mentioned approvals or conformities.

3.2. Conformity



In accordance with the Declaration of Conformity, the product is compliant with the EU Directives.

3.3. Standards





The applied standards which are used to demonstrate compliance with the EU Directives are listed in the EU-Type Examination Certificate and/or the EU Declaration of Conformity.

DTS 1000582645 EN Version: F Status: RL (released | freigegeben | valide) printed: 15.01.2026

3.4. Explosion protection

Approval	Description								
 	<p>Optional: Explosion protection according to category 2 (zone 1/21)</p> <p>Ex marking of the components according to the following table:</p> <table border="1"> <thead> <tr> <th colspan="2">Coil Type AC10</th> </tr> <tr> <th>Coils with cable outlet</th> <th>Coils with terminal box</th> </tr> </thead> <tbody> <tr> <td> ATEX: EPS 18 ATEX 1232 X II 2G Ex mb IIC T4 Gb II 2D Ex mb IIIC T130 °C Db </td> <td> ATEX: EPS 18 ATEX 1232 X II 2G Ex eb mb IIC T4 Gb II 2D Ex mb tb IIIC T130 °C Db </td> </tr> <tr> <td> IECEX: IECEX EPS 18.0110 X Ex mb IIC T4 Gb Ex mb IIIC T130 °C Db </td> <td> IECEX: IECEX EPS 18.0110 X Ex eb mb IIC T4 Gb Ex mb tb IIIC T130 °C Db </td> </tr> </tbody> </table>	Coil Type AC10		Coils with cable outlet	Coils with terminal box	ATEX: EPS 18 ATEX 1232 X II 2G Ex mb IIC T4 Gb II 2D Ex mb IIIC T130 °C Db	ATEX: EPS 18 ATEX 1232 X II 2G Ex eb mb IIC T4 Gb II 2D Ex mb tb IIIC T130 °C Db	IECEX: IECEX EPS 18.0110 X Ex mb IIC T4 Gb Ex mb IIIC T130 °C Db	IECEX: IECEX EPS 18.0110 X Ex eb mb IIC T4 Gb Ex mb tb IIIC T130 °C Db
	Coil Type AC10								
Coils with cable outlet	Coils with terminal box								
ATEX: EPS 18 ATEX 1232 X II 2G Ex mb IIC T4 Gb II 2D Ex mb IIIC T130 °C Db	ATEX: EPS 18 ATEX 1232 X II 2G Ex eb mb IIC T4 Gb II 2D Ex mb tb IIIC T130 °C Db								
IECEX: IECEX EPS 18.0110 X Ex mb IIC T4 Gb Ex mb IIIC T130 °C Db	IECEX: IECEX EPS 18.0110 X Ex eb mb IIC T4 Gb Ex mb tb IIIC T130 °C Db								
<p>Optional: Explosion protection according to category 3 (zone 2/22)</p> <p>Ex marking of the components according to the following table:</p> <table border="1"> <thead> <tr> <th colspan="2">Coil Type AC10</th> </tr> <tr> <th colspan="2">Coil with plug contacts form A and cable plug Type 2509</th> </tr> </thead> <tbody> <tr> <td colspan="2"> ATEX: EPS 18 ATEX 1232 X II 2G Ex mb IIC T4 Gb II 2D Ex mb IIIC T130 °C Db </td> </tr> <tr> <td colspan="2"> IECEX: IECEX EPS 18.0110 X Ex mb IIC T4 Gb Ex mb IIIC T130 °C Db </td> </tr> </tbody> </table>	Coil Type AC10		Coil with plug contacts form A and cable plug Type 2509		ATEX: EPS 18 ATEX 1232 X II 2G Ex mb IIC T4 Gb II 2D Ex mb IIIC T130 °C Db		IECEX: IECEX EPS 18.0110 X Ex mb IIC T4 Gb Ex mb IIIC T130 °C Db		
Coil Type AC10									
Coil with plug contacts form A and cable plug Type 2509									
ATEX: EPS 18 ATEX 1232 X II 2G Ex mb IIC T4 Gb II 2D Ex mb IIIC T130 °C Db									
IECEX: IECEX EPS 18.0110 X Ex mb IIC T4 Gb Ex mb IIIC T130 °C Db									

3.5. North America (USA/Canada)

Approval	Description
	<p>Optional: UL Listed for the USA (valid for valves)</p> <p>The valves are UL Listed for the USA according to:</p> <ul style="list-style-type: none"> UL 429 (electrically operated valves) and UL 429 A (Electrically Operated Valves for Fire Protection Service)
	<p>Optional: UL Hazardous Locations – Explosion Protection (valid for coils)</p> <p>UL Listed for Hazardous Locations for USA and Canada</p> <p>Class I, Zone 1</p> <p>Class I, Division 2, Group A, B, C and D</p> <p>Class II + III, Division 2, Group F and G</p>
	<p>Optional: UL Recognized for the USA (valid for valves)</p> <p>The valves are UL Recognized for the USA according to:</p> <ul style="list-style-type: none"> UL 429 (electrically operated valves) and UL 429 A (Electrically Operated Valves for Fire Protection Service)
	<p>Optional: CSA for Canada (valid for valves)</p> <p>The valves are CSA approved for Canada according to:</p> <ul style="list-style-type: none"> CSA 139 (electrically operated valves)
	<p>Optional: FM (Factory Mutual) – Explosion Protection (valid for coils)</p> <p>FM for Hazardous Locations for USA and Canada</p> <p>Class I, Zone 1</p> <p>Class I, Division 1, Groups A, B, C and D</p> <p>Class II + III, Division 1, Groups E, F and G</p>

DTS 1000582645 EN Version: F Status: RL (released | freigegeben | valide) printed: 15.01.2026

3.6. Others

Oxygen

Conformity	Description
O₂	Optional: Suitability for oxygen (valid for the variable code NL02) The products are suitable for use with gaseous oxygen, according to the manufacturer's declaration.

4. Materials

4.1. Bürkert resistApp

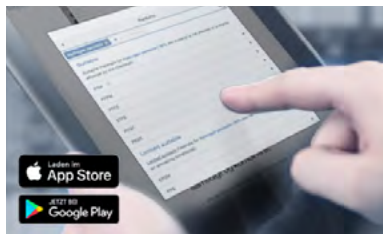

Bürkert resistApp – Chemical resistance chart

You want to ensure the reliability and durability of the materials in your individual application case? Verify your combination of media and materials on our website or in our resistApp.

Start chemical resistance check

4.2. Material specifications standard variant

DN 12, circuit function A

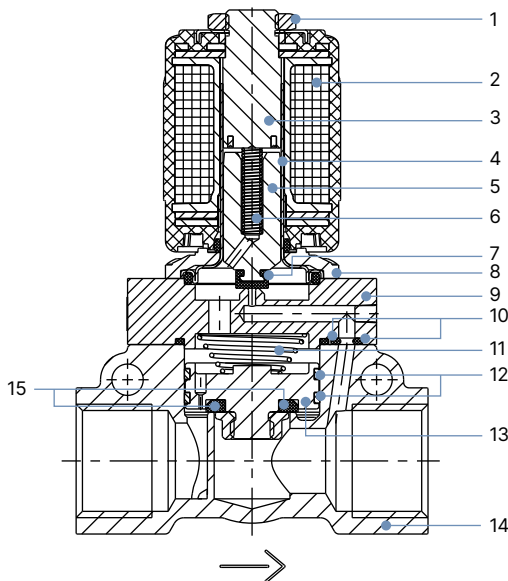

No.	Element	Material
1	Nut	Steel (thick-film passivated according to RoHS)
2	Coil	Epoxy (polyamide optional)
3	Stopper	Stainless steel 1.4105/303 ¹⁾
4	Armature guide tube	Stainless steel 1.4303/305 ¹⁾ /308 ¹⁾
5	Plunger	Stainless steel 1.4105/430F ¹⁾
6	Spring	Stainless steel 1.4310/301 ¹⁾
7	Plunger seal	FKM (EPDM optional)
8	Flange	Steel (thick-film passivated according to RoHS)
9	Cover	Brass
10	O-ring	FKM (EPDM optional)
11	Spring	Stainless steel 1.4310/301 ¹⁾
12	Piston ring	PTFE
13	Piston	Brass
14	Valve body	Brass
15	Piston seal	PTFE

1.) Material designation according to AISI

DTS 1000582645 EN Version: F Status: RL (released | freigegeben | valide) printed: 15.01.2026

DN 25, circuit function B

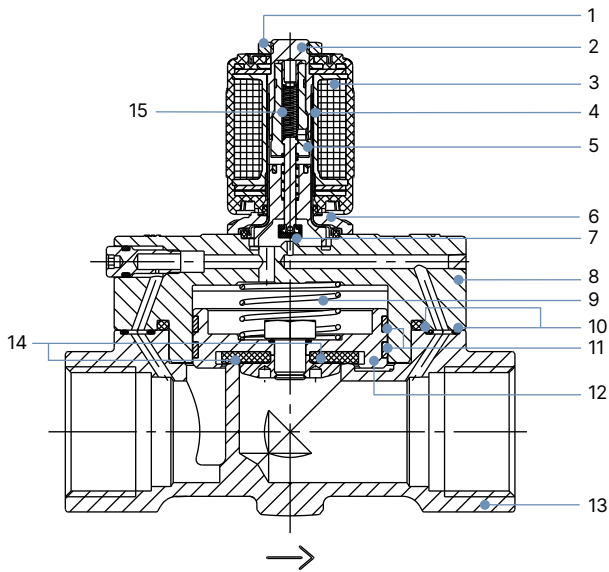

No.	Element	Material
1	Nut	Steel (thick-film passivated according to RoHS)
2	Stopper	Stainless steel 1.4113/434 ¹⁾
3	Coil	Epoxy
4	Armature guide tube	Stainless steel 1.4303/305 ¹⁾ /308 ¹⁾
5	Plunger	Stainless steel 1.4113/434 ¹⁾ /1.4305/303 ¹⁾
6	Flange	Steel (thick-film passivated according to RoHS)
7	Plunger seal	FKM (EPDM optional)
8	Cover	Brass
9	Spring	Stainless steel 1.4310/301 ¹⁾
10	O-ring	FKM (EPDM optional)
11	Piston ring	PTFE
12	Piston	Brass
13	Valve body	Brass
14	Piston seal	PTFE
15	Spring	Stainless steel 1.4310/301 ¹⁾

1.) Material designation according to AISI

DN 32, circuit function A

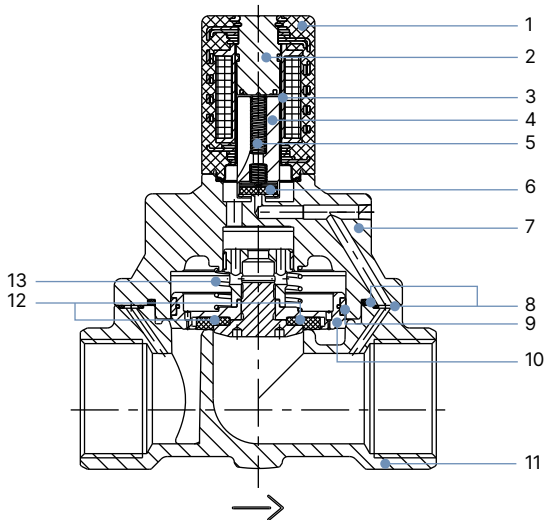

No.	Element	Material
1	Coil	Epoxy
2	Stopper	Stainless steel 1.4105/430F ¹⁾
3	Armature guide tube	Stainless steel 1.4303/305 ¹⁾ /308 ¹⁾
4	Plunger	Stainless steel 1.4105/430F ¹⁾
5	Spring	Stainless steel 1.4310/301 ¹⁾
6	Plunger seal	FKM
7	Cover	Brass
8	O-ring	FKM
9	Piston ring	PTFE
10	Piston	Brass
11	Valve body	Brass
12	Piston seal	PTFE
13	Spring	Stainless steel 1.4310/301 ¹⁾

1.) Material designation according to AISI

DTS 1000582645 EN Version: F Status: RL (released | freigegeben | valide) printed: 15.01.2026

4.3. Material specifications steam variant NA07

DN 13, circuit function A

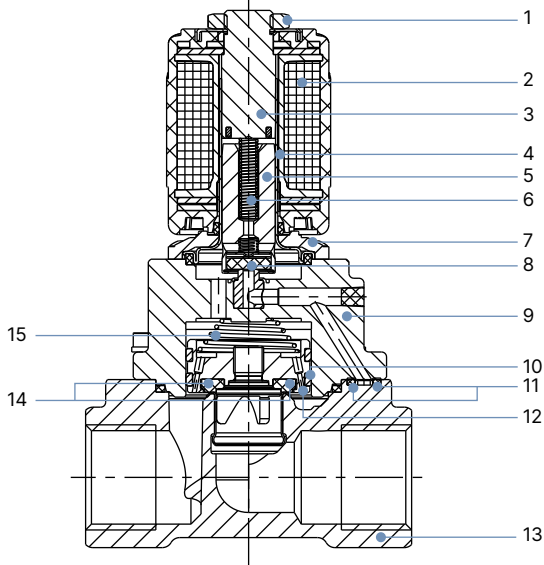

No.	Element	Material
1	Nut	Steel (thick-film passivated according to RoHS)
2	Coil	Epoxy
3	Stopper	Stainless steel 1.4113/434 ¹⁾
4	Armature guide tube	Stainless steel 1.4303/305 ¹⁾
5	Plunger	Stainless steel 1.4113/434 ¹⁾
6	Spring	Stainless steel 1.4310/301 ¹⁾
7	Flange	Steel (thick-film passivated according to RoHS)
8	Plunger seal	PTFE
9	Cover	Brass
10	Piston ring	PTFE
11	O-ring	Graphite
12	Piston	Brass
13	Valve body	Brass
14	Piston seal	PTFE
15	Spring	Stainless steel 1.4310/301 ¹⁾

1.) Material designation according to AISI

DN 32, circuit function A, flange body

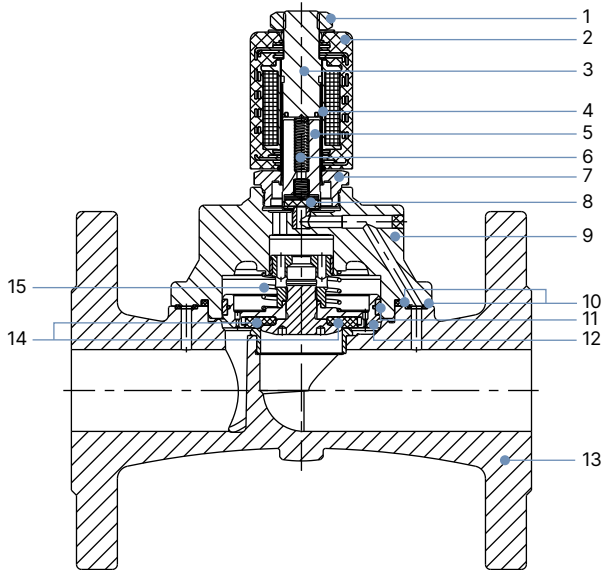

No.	Element	Material
1	Nut	Steel (thick-film passivated according to RoHS)
2	Coil	Epoxy
3	Stopper	Stainless steel 1.4113/434 ¹⁾
4	Armature guide tube	Stainless steel 1.4571/316Ti ¹⁾
5	Plunger	Stainless steel 1.4113/434 ¹⁾
6	Spring	Stainless steel 1.4310/301 ¹⁾
7	Threaded tube	Stainless steel 1.4401/316 ¹⁾ or 1.4571/316Ti ¹⁾
8	Plunger seal	PTFE
9	Cover	Brass
10	O-ring	Graphite
11	Piston ring	PTFE
12	Piston	Brass
13	Valve body	Stainless steel 1.4581/similar 316Ti ¹⁾
14	Piston seal	PTFE
15	Spring	Stainless steel 1.4310/301 ¹⁾

1.) Material designation according to AISI

DTS 1000582645 EN Version: F Status: RL (released | freigegeben | valide) printed: 15.01.2026

4.4. Material specifications high pressure variant PN 08

DN 12, circuit function A

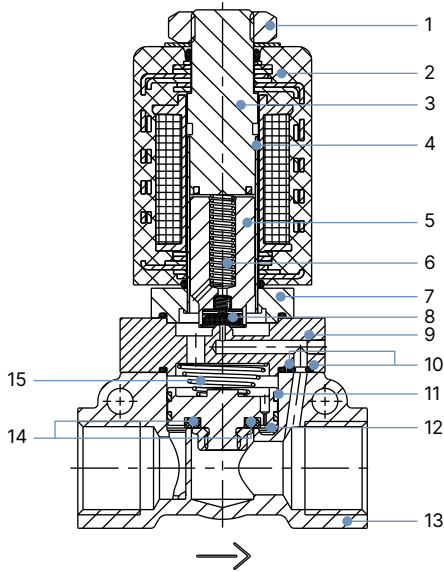

No.	Element	Material
1	Nut	Steel (thick-film passivated according to RoHS)
2	Coil	Epoxy (polyamide)
3	Stopper	Stainless steel 1.4113/434 ¹⁾
4	Armature guide tube	Stainless steel 1.4571/316Ti ¹⁾
5	Plunger	Stainless steel 1.4113/434 ¹⁾
6	Spring	Stainless steel 1.4310/301 ¹⁾
7	Flange	Stainless steel 1.4401/316 ¹⁾
8	Plunger seal	PTFE
9	Cover	Brass
10	O-ring	FKM
11	Piston ring	PTFE
12	Piston	Brass
13	Valve body	Brass
14	Piston seal	PTFE
15	Spring	Stainless steel 1.4310/301 ¹⁾

1.) Material designation according to AISI

4.5. Material specifications discharge valve for compressor systems CF05

DN 12, circuit function B

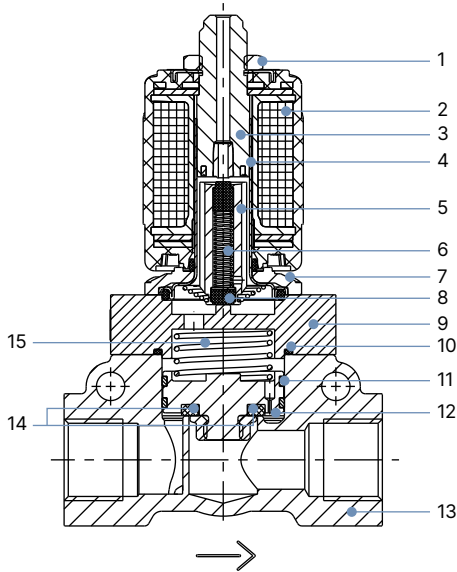

No.	Element	Material
1	Nut	Steel (thick-film passivated according to RoHS)
2	Coil	Epoxy (polyamide optional)
3	Stopper	Stainless steel 1.4105/430F ¹⁾
4	Armature guide tube	Stainless steel 1.4303/305 ¹⁾
5	Plunger	Stainless steel 1.4105/430F ¹⁾
6	Spring	Stainless steel 1.4310/301 ¹⁾
7	Flange	Steel (thick-film passivated according to RoHS)
8	Plunger seal	FKM
9	Cover	Brass
10	O-ring	FKM
11	Piston ring	PTFE
12	Piston	Brass
13	Valve body	Brass
14	Piston seal	PTFE
15	Spring	Stainless steel 1.4310/301 ¹⁾

1.) Material designation according to AISI

DTS 1000582645 EN Version: F Status: RL (released | freigegeben | valide) printed: 15.01.2026

5. Dimensions

5.1. Standard variant

Threaded variant DN 12

Note:

- Dimensions in mm [inch]
- The dimensions D1 and F1 apply to G thread.
- The dimensions D2 and F2 apply to NPT thread.
- The dimensions D3 and F3 apply to Rc thread.

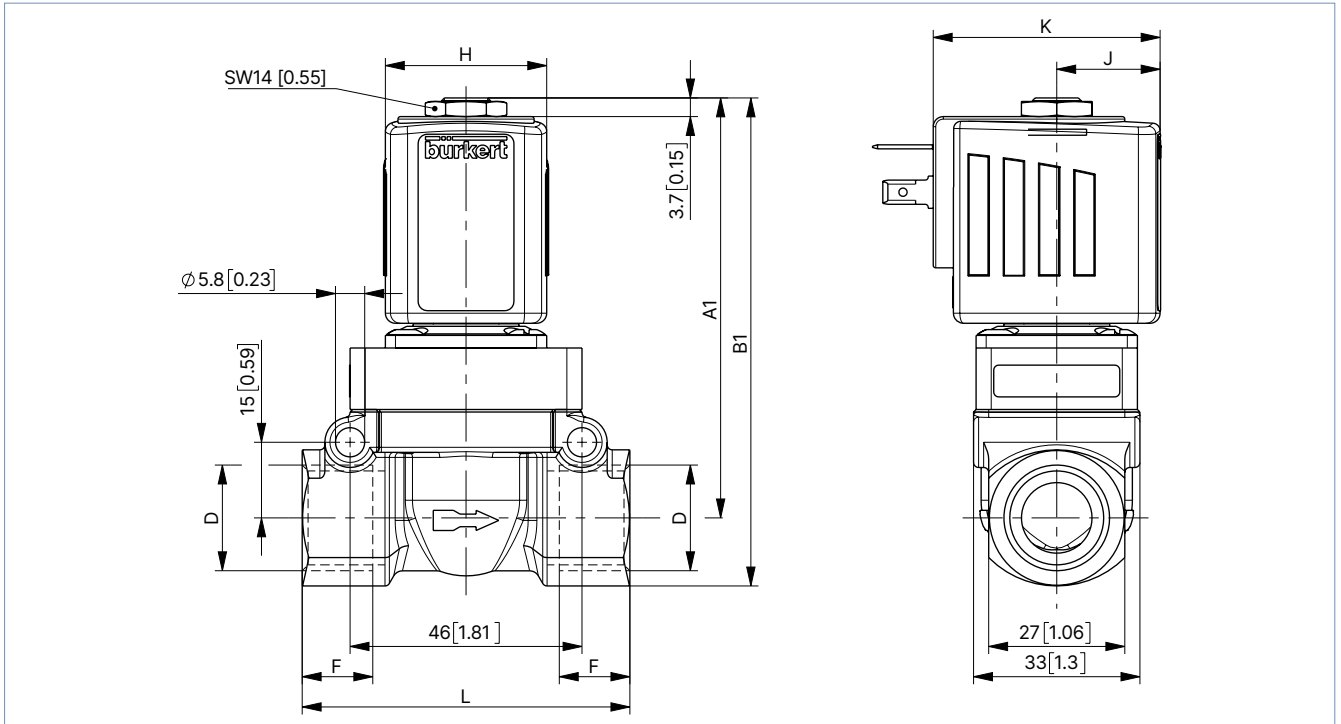

Coil size	DN	CFA				CFB			
		A1		B1		A1		B1	
		[mm]	[in]	[mm]	[in]	[mm]	[in]	[mm]	[in]
5	12.0	83	3.27	97	3.82	86	3.39	100	3.94
6		83	3.27	97	3.82	86	3.39	100	3.94

Coil size	DN	G thread			NPT thread			Rc thread			L		H		J		K	
		D1	F1		D2	F2		D3	F3		[mm]	[in]	[mm]	[in]	[mm]	[in]	[mm]	[in]
		[Zoll]	[mm]	[in]	[Zoll]	[mm]	[in]	[Zoll]	[mm]	[in]	[mm]	[in]	[mm]	[in]	[mm]	[in]	[mm]	[in]
5	12.0	G ½	14	0.55	NPT ½	13.7	0.54	Rc ½	13.2	0.52	65	2.56	32	1.26	20.5	0.81	45	1.77
6		G ½	14	0.55	NPT ½	13.7	0.54	Rc ½	13.2	0.52	65	2.56	40	1.57	23.5	0.93	51	2.01

DTS 1000582645 EN Version: F Status: RL (released | freigegeben | valide) printed: 15.01.2026

Threaded variant DN 20 and DN 25

Note:

- Dimensions in mm [inch]
- The dimensions D1 and F1 apply to G thread.
- The dimensions D2 and F2 apply to NPT thread.
- The dimensions D3 and F3 apply to Rc thread.

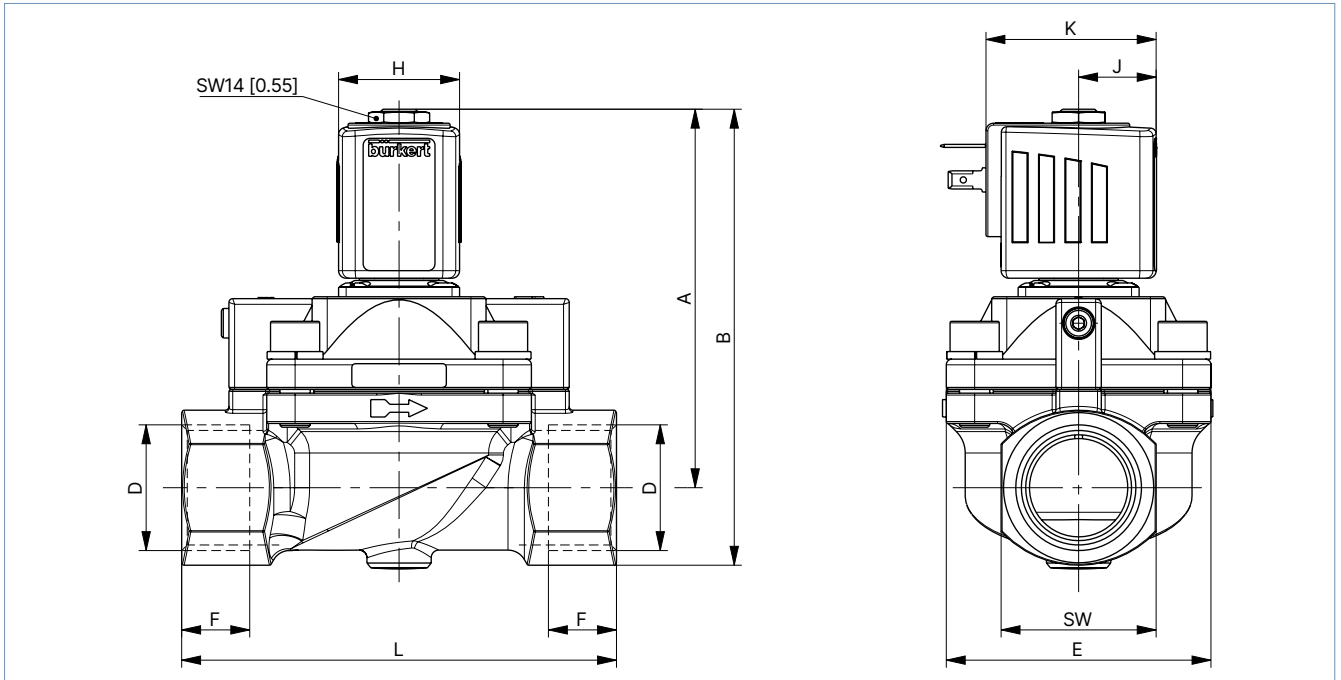

Coil size	DN	CFA / CFB				G thread			NPT thread			Rc thread		
		A		B		D1	F1		D2	F2		D3	F3	
		[mm]	[in]	[mm]	[in]	[Zoll]	[mm]	[in]	[Zoll]	[mm]	[in]	[Zoll]	[mm]	[in]
5	20.0	96	3.78	112	4.41	G 3/4	16	0.63	NPT 3/4	14	0.55	-	-	-
	25.0	100	3.94	121	4.76	G 1	18	0.71	NPT 1	16.8	0.66	Rc 1	16.8	0.66
6	20.0	96	3.78	112	4.41	G 3/4	16	0.63	NPT 3/4	14	0.55	-	-	-
	25.0	100	3.94	121	4.76	G 1	18	0.71	NPT 1	16.8	0.66	-	-	-

Coil size	DN	E		L		SW		H		J		K	
		[mm]	[in]	[mm]	[in]	[mm]	[in]	[mm]	[in]	[mm]	[in]	[mm]	[in]
5	20.0	60	2.36	100	3.94	32	1.26	32	1.26	20.5	0.81	45	1.77
	25.0	70	2.76	115	4.53	41	1.61						
6	20.0	60	2.36	100	3.94	32	1.26	40	1.57	23.5	0.93	51	2.01
	25.0	70	2.76	115	4.53	41	1.61						

DTS 1000582645 EN Version: F Status: RL (released | freigegeben | valide) printed: 15.01.2026

Threaded variant DN 32 and DN 50

Note:

- Dimensions in mm [inch]
- The dimensions D1 and F1 apply to G thread.
- The dimensions D2 and F2 apply to NPT thread.

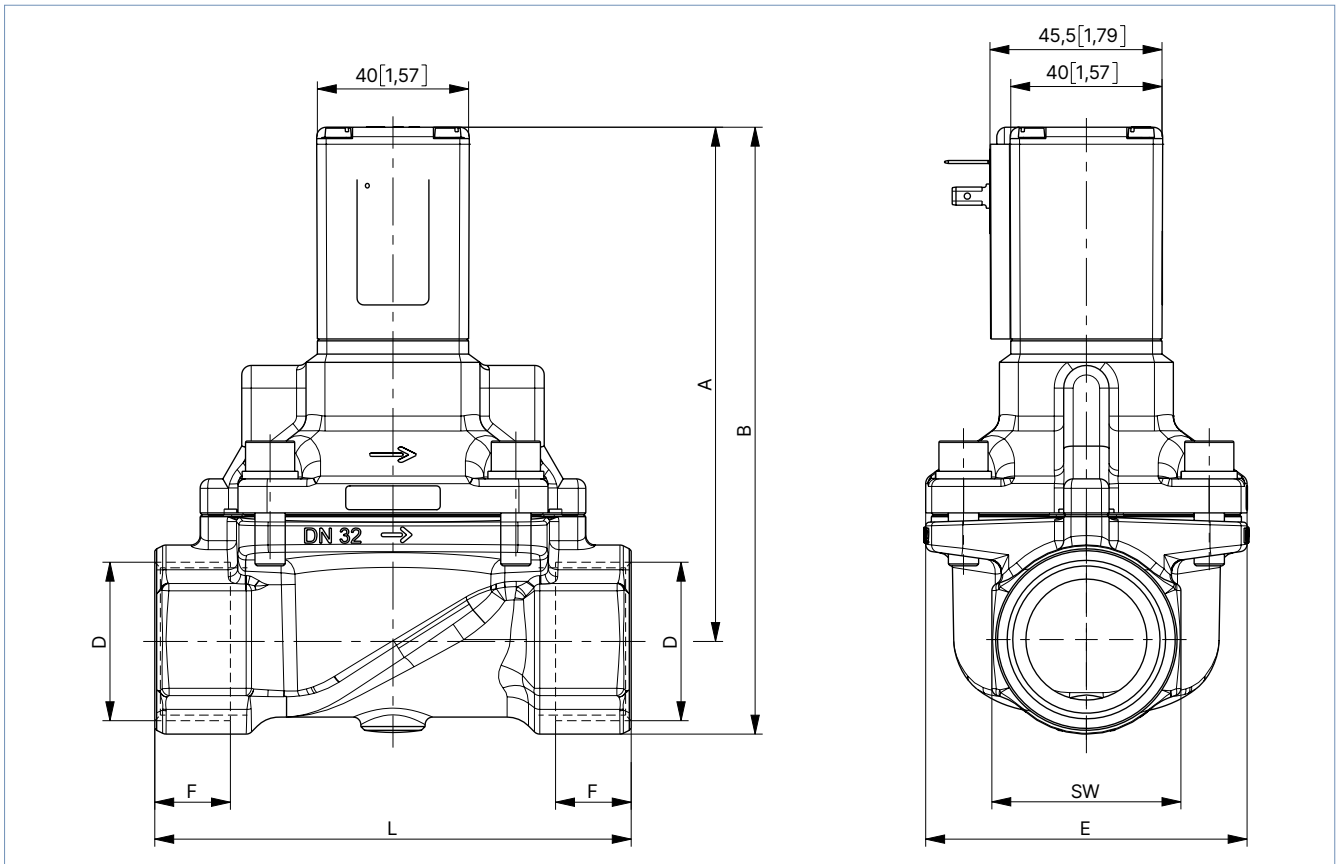

DN	A		B		G thread			NPT thread			E		L		SW	
	[mm]	[in]	[mm]	[in]	D1	F1		D2	F2		[mm]	[in]	[mm]	[in]	[mm]	[in]
					[Zoll]	[mm]	[in]	[Zoll]	[mm]	[in]						
32.0	136	5.35	161	6.34	G 1¼	20	0.79	NPT 1¼	17.3	0.68	85	3.35	126	4.96	50	1.97
40.0	140	5.51	170	6.69	G 1½	22	0.87	NPT 1½	17.3	0.68	85	3.35	126	4.96	60	2.36
50.0	163	6.42	198	7.80	G 2	24	0.94	NPT 2	17.6	0.69	115	4.53	164	6.46	70	2.76

DTS 1000582645 EN Version: F Status: RL (released | freigegeben | valide) printed: 15.01.2026

5.2. Steam variant NA07

Threaded variant DN 13

Note:

- Dimensions in mm [inch]
- The dimensions D1 and F1 apply to G thread.
- The dimensions D2 and F2 apply to NPT thread.
- The dimensions D3 and F3 apply to Rc thread.

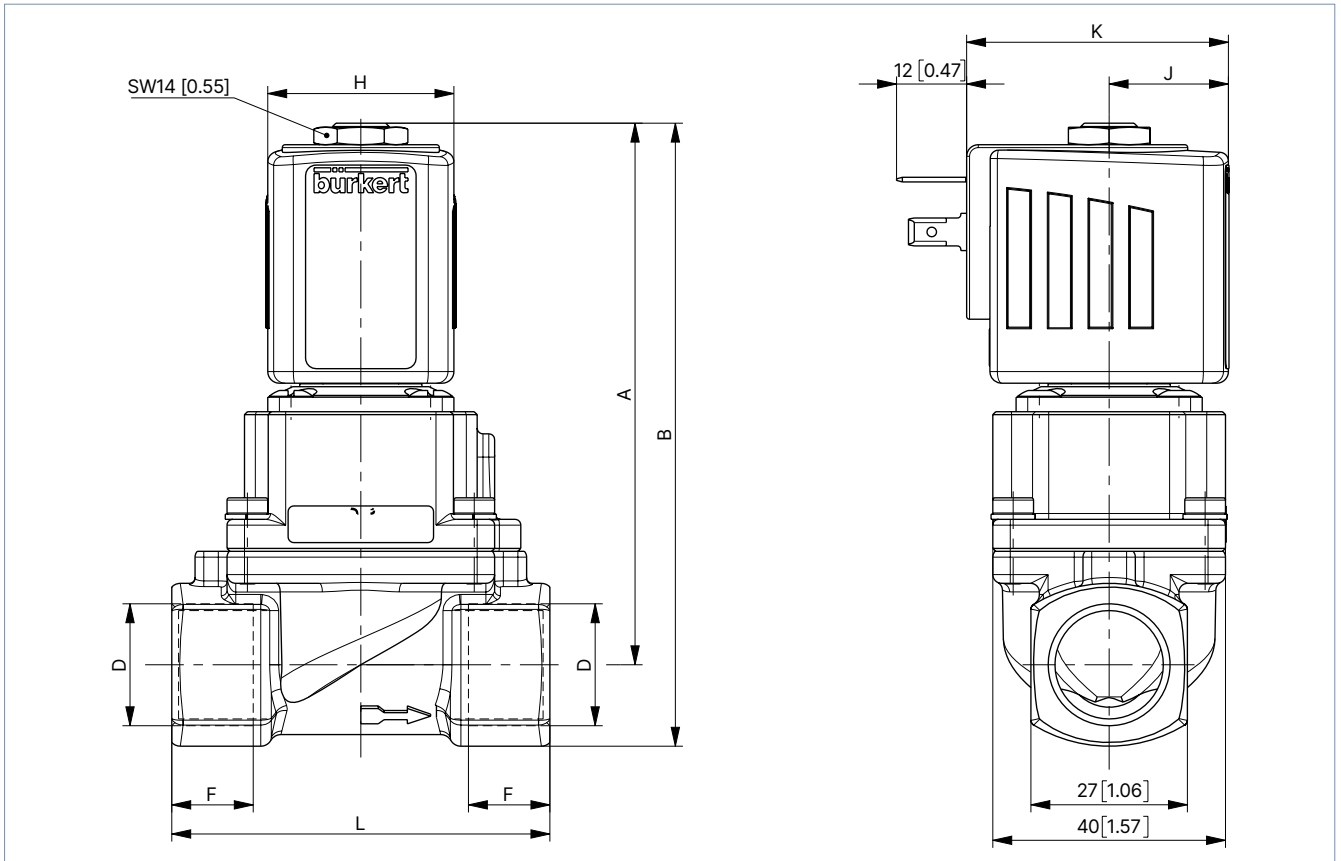

Coil size	DN	A		B		G thread			NPT thread			Rc thread		
		[mm]	[in]	[mm]	[in]	D1 [Zoll]	F1 [mm]	[in]	D2 [Zoll]	F2 [mm]	[in]	D3 [Zoll]	F3 [mm]	[in]
5	13.0	93.1	3.67	107.1	4.20	G ½	14	0.55	NPT ½	13.7	0.54	Rc ½	13.2	0.52
6		93.1	3.67	107.1	4.20	G ½	14	0.55	NPT ½	13.7	0.54	Rc ½	13.2	0.52

Coil size	DN	L		H		J		K	
		[mm]	[in]	[mm]	[in]	[mm]	[in]	[mm]	[in]
5	13.0	65	2.56	32	1.26	20.5	0.81	45	1.77
6		65	2.56	40	1.57	23.5	0.93	51	2.01

DTS 1000582645 EN Version: RL (released | freigegeben | valide) printed: 15.01.2026

Threaded variant DN 20 and DN 25

Note:

- Dimensions in mm [inch]
- The dimensions D1 and F1 apply to G thread.
- The dimensions D2 and F2 apply to NPT thread.
- The dimensions D3 and F3 apply to Rc thread.

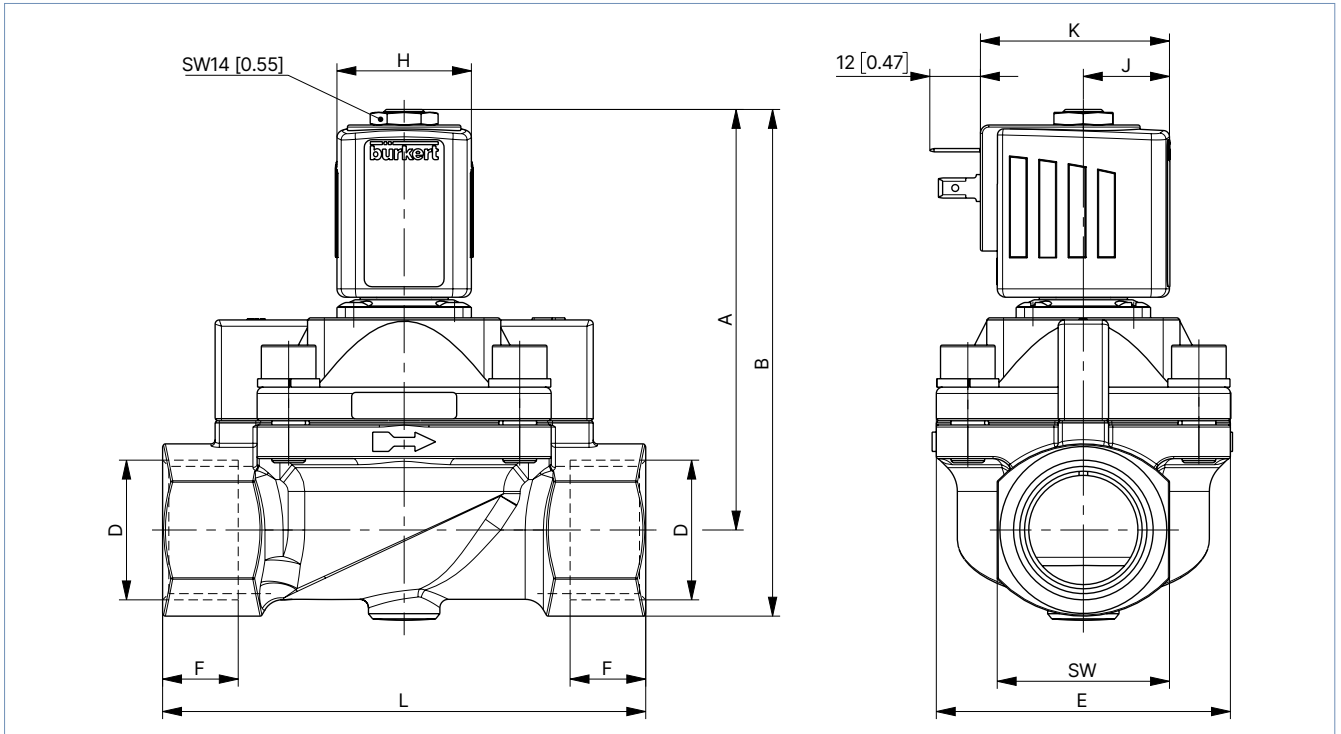

Coil size	DN	A				B				G thread			NPT thread			Rc thread	
		[mm]		[in]		[mm]		[in]		D1	F1	D2	F2	D3	F3		
		[mm]	[in]	[mm]	[in]	[Zoll]	[mm]	[in]	[Zoll]	[mm]	[in]	[Zoll]	[mm]	[in]			
5	20.0	96.1	3.78	112.1	4.41	G 3/4	16	0.63	NPT 3/4	14	0.55	Rc 3/4	14.5	0.57			
	25.0	100.1	3.94	120.6	4.75	G 1	18	0.71	NPT 1	16.8	0.66	Rc 1	16.8	0.66			
6	20.0	96.1	3.78	112.1	4.41	G 3/4	16	0.63	NPT 3/4	14	0.55	Rc 3/4	14.5	0.57			
	25.0	100.1	3.94	120.6	4.75	G 1	18	0.71	NPT 1	16.8	0.66	Rc 1	16.8	0.66			

Coil size	DN	E		L		SW		H		J		K	
		[mm]	[in]	[mm]	[in]	[mm]	[in]	[mm]	[in]	[mm]	[in]	[mm]	[in]
5	20.0	60	2.36	100	3.94	32	1.26	32	1.26	20.5	0.81	45	1.77
	25.0	70	2.76	115	4.53	41	1.61						
6	20.0	60	2.36	100	3.94	32	1.26	40	1.57	23.5	0.93	51	2.01
	25.0	70	2.76	115	4.53	41	1.61						

DTS 1000582645 EN Version: F Status: RL (released | freigegeben | valide) printed: 15.01.2026

Flange variant DN 25

Note:

Dimensions in mm [inch]

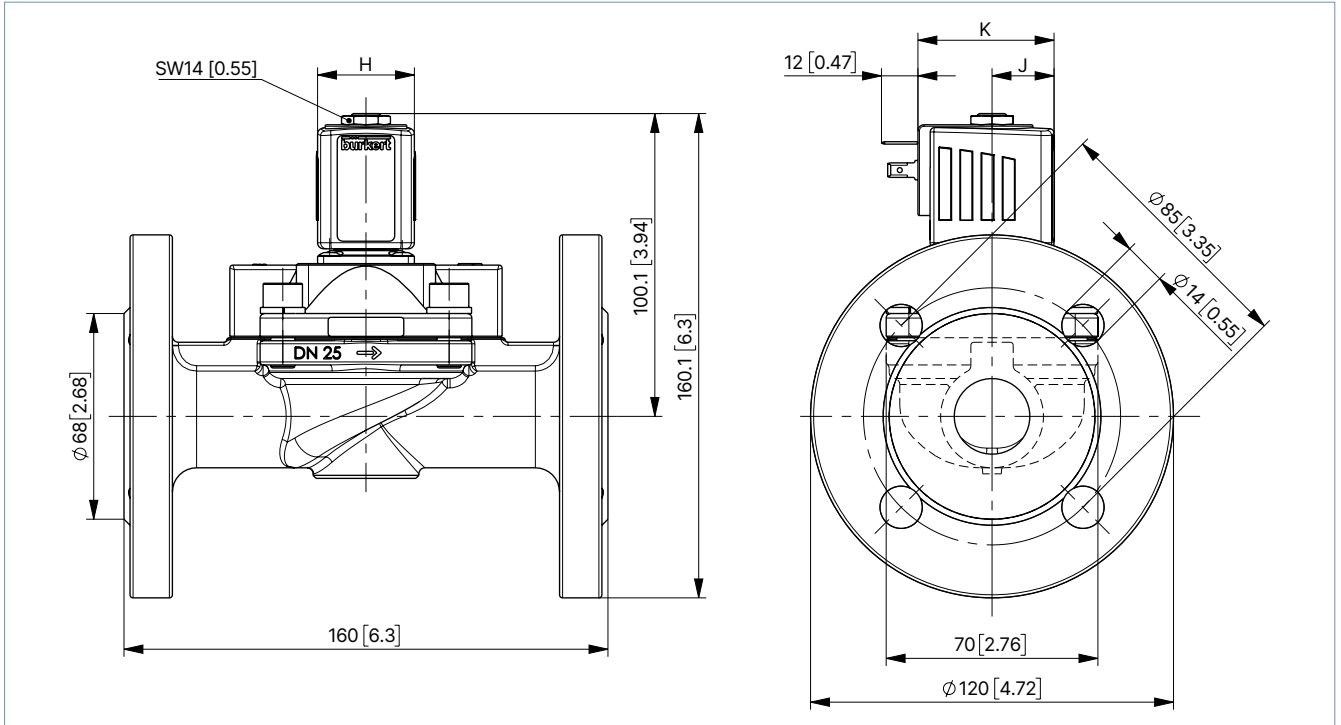

Coil size	DN	H		J		K	
		[mm]	[in]	[mm]	[in]	[mm]	[in]
5	25	32	1.26	20.5	0.81	45	1.77
6	25	40	1.57	23.5	0.93	51	2.01

Threaded variant DN 32 and DN 40

- Dimensions in mm [inch]
- The dimensions D1 and F1 apply to G thread.
- The dimensions D2 and F2 apply to NPT thread.

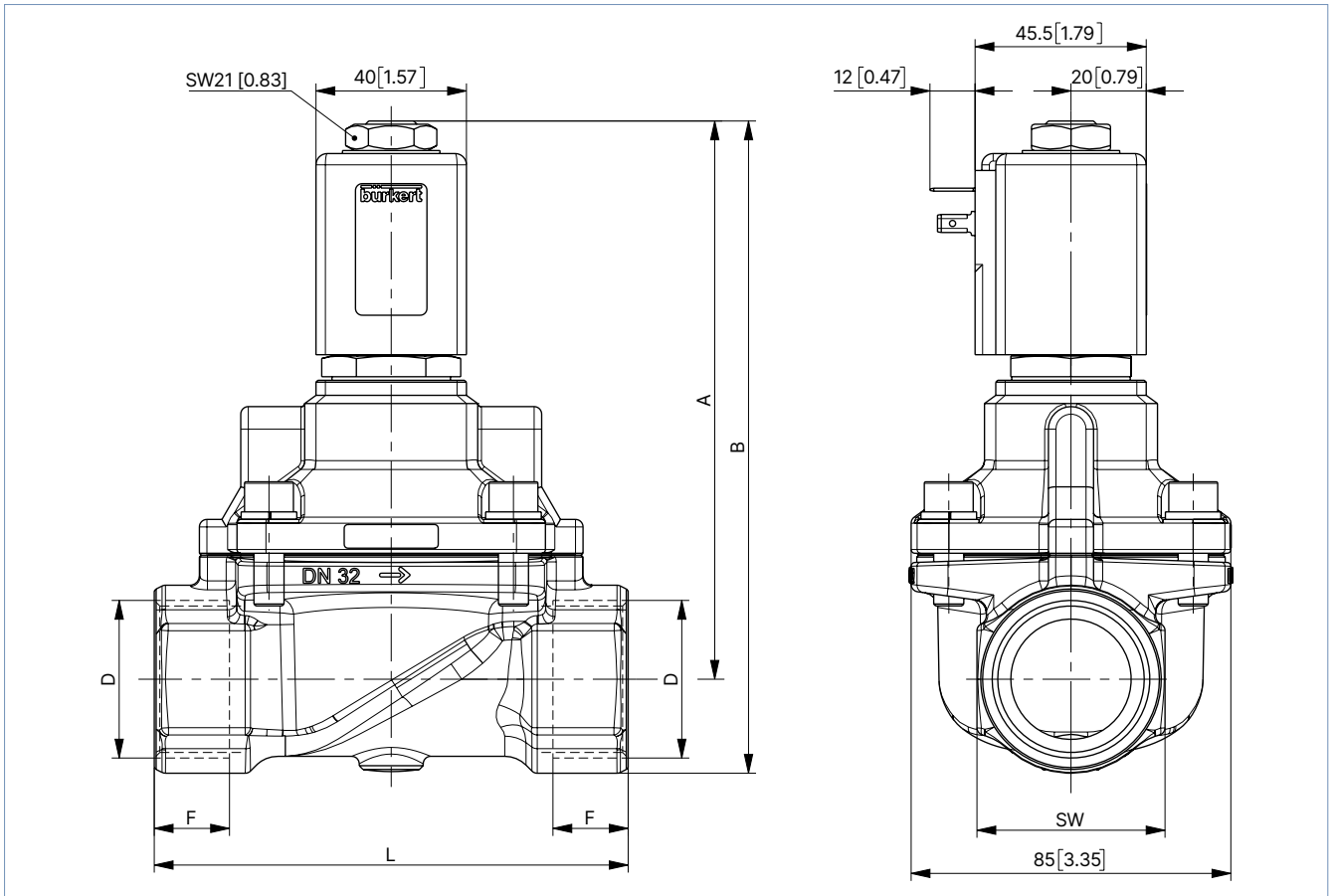

Coil size	DN	A		B		G thread			NPT thread			L		SW	
		[mm]	[in]	[mm]	[in]	D1	F1	D2	F2	[mm]	[in]	[mm]	[in]		
						[Zoll]	[mm]	[in]	[Zoll]	[mm]	[in]				
C	32.0	148	5.83	173	6.81	G 1 ¼	20	0.79	NPT 1 ¼	17.3	0.68	126	4.96	50	1.97
	40.0	153	6.02	181	7.13	G 1 ½	22	0.79	NPT 1 ½	17.3	0.68			60	2.36

DTS 1000582645 EN Version: F Status: RL (released | freigegeben | valide) printed: 15.01.2026

Flange variant DN 32 and DN 40

Note:

Dimensions in mm [inch]

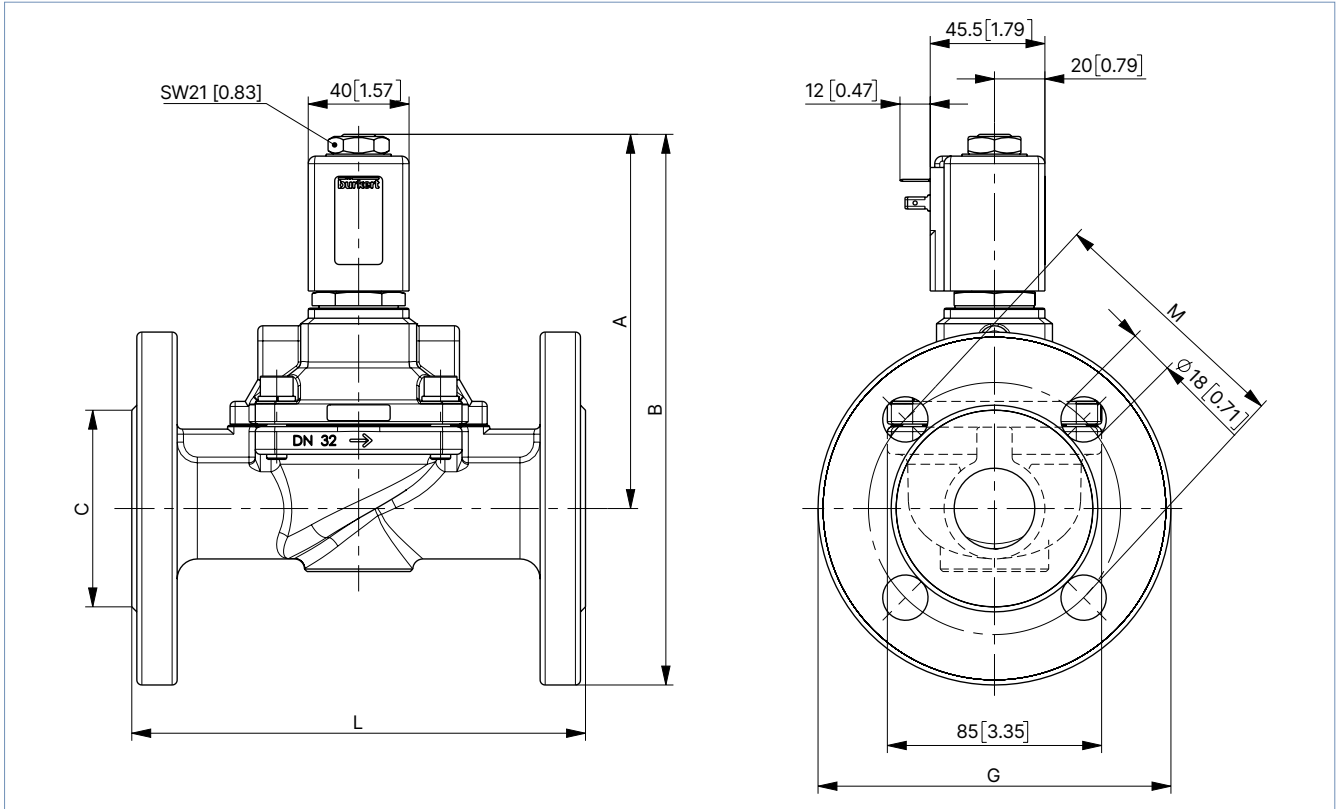

Coil size	DN	A		B		C		G		L		M	
		[mm]	[in]	[mm]	[in]	[mm]	[in]	[mm]	[in]	[mm]	[in]	[mm]	[in]
C	32	148	5.83	218	8.58	78	3.07	140	5.51	180	7.09	100	3.94
	40	153	6.02	227	8.94	88	3.46	150	5.91	200	7.87	110	4.33

5.3. High pressure variant up to 1160 psi (PN 08)

Note:

- Dimensions in mm [inch]
- The dimensions D1 and F1 apply to G thread.
- The dimensions D2 and F2 apply to NPT thread.

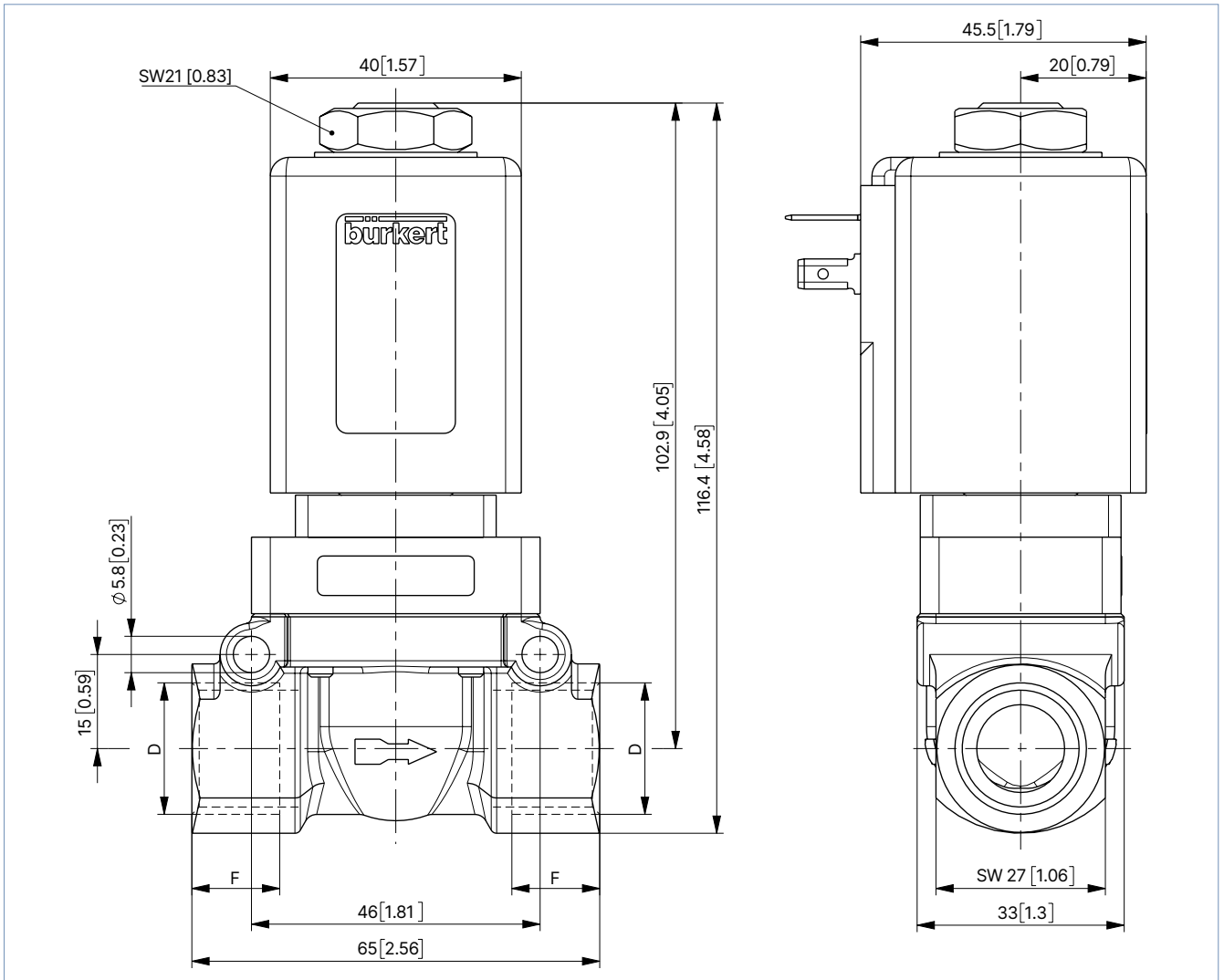

G thread			NPT thread		
D1	F1		D2	F2	
[Zoll]	[mm]	[in]	[Zoll]	[mm]	[in]
G 1/2	14	0.55	NPT 1/2	13.7	0.54

DTS 1000582645 EN Version: F Status: RL (released | freigegeben | valide) printed: 15.01.2026

5.4. Discharge valve for compressor systems CF05

Plug variant with ventilation

Note:

- Dimensions in mm [inch]
- The dimensions D1 and F1 apply to G thread.
- The dimensions D2 and F2 apply to NPT thread.

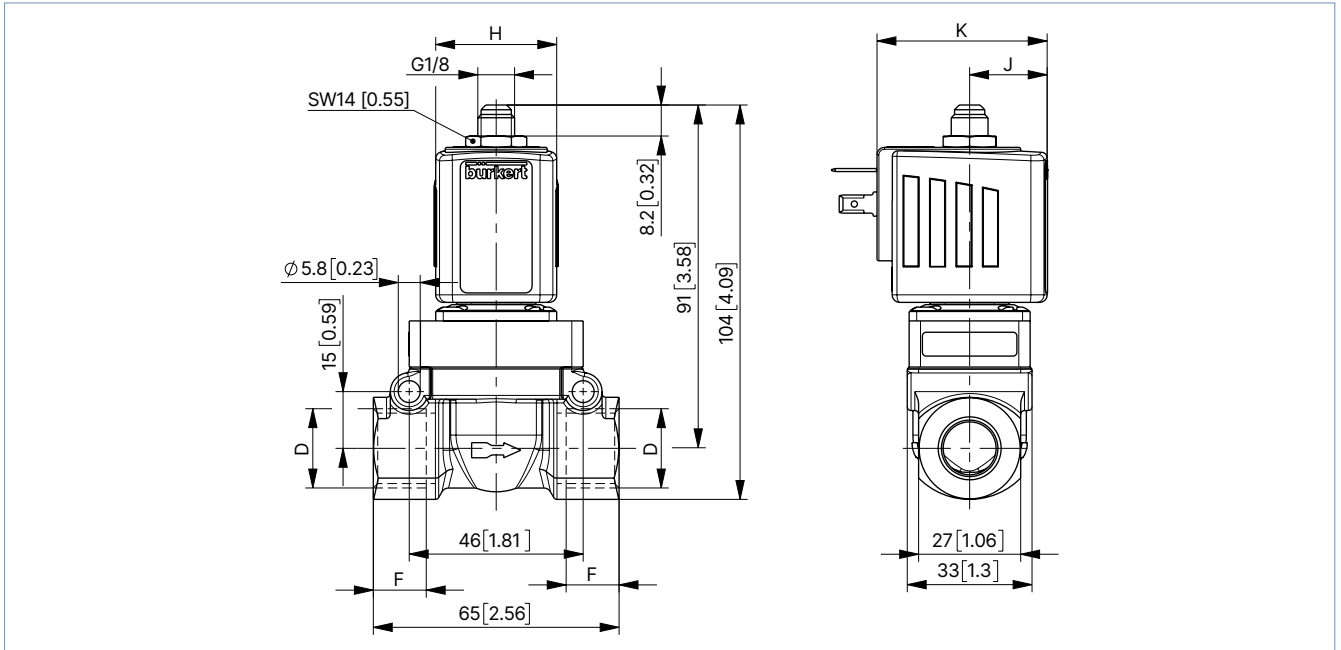

Coil size	G thread			NPT thread			H		J		K	
	D1	F1		D2	F2		[mm]	[in]	[mm]	[in]	[mm]	[in]
	[Zoll]	[mm]	[in]	[Zoll]	[mm]	[in]						
5	G ¼	12	0.47	NPT ¼	10	0.39	32	1.26	20.5	0.81	45	1.77
	G ½	14	0.55	NPT ½	13.7	0.54						
6	G ½	14	0.55	NPT ½	13.7	0.54	40	1.57	23.5	0.93	51	2.01

DTS 1000582645 EN Version: F Status: RL (released | freigegeben | valide) printed: 15.01.2026

5.5. Coil UL Listed for hazardous locations, Class I, Division 2

Note:

- Dimensions in mm [inch]
- The dimensions D1 and F1 apply to G thread.
- The dimensions D2 and F2 apply to NPT thread.
- The dimensions D3 and F3 apply to Rc thread.

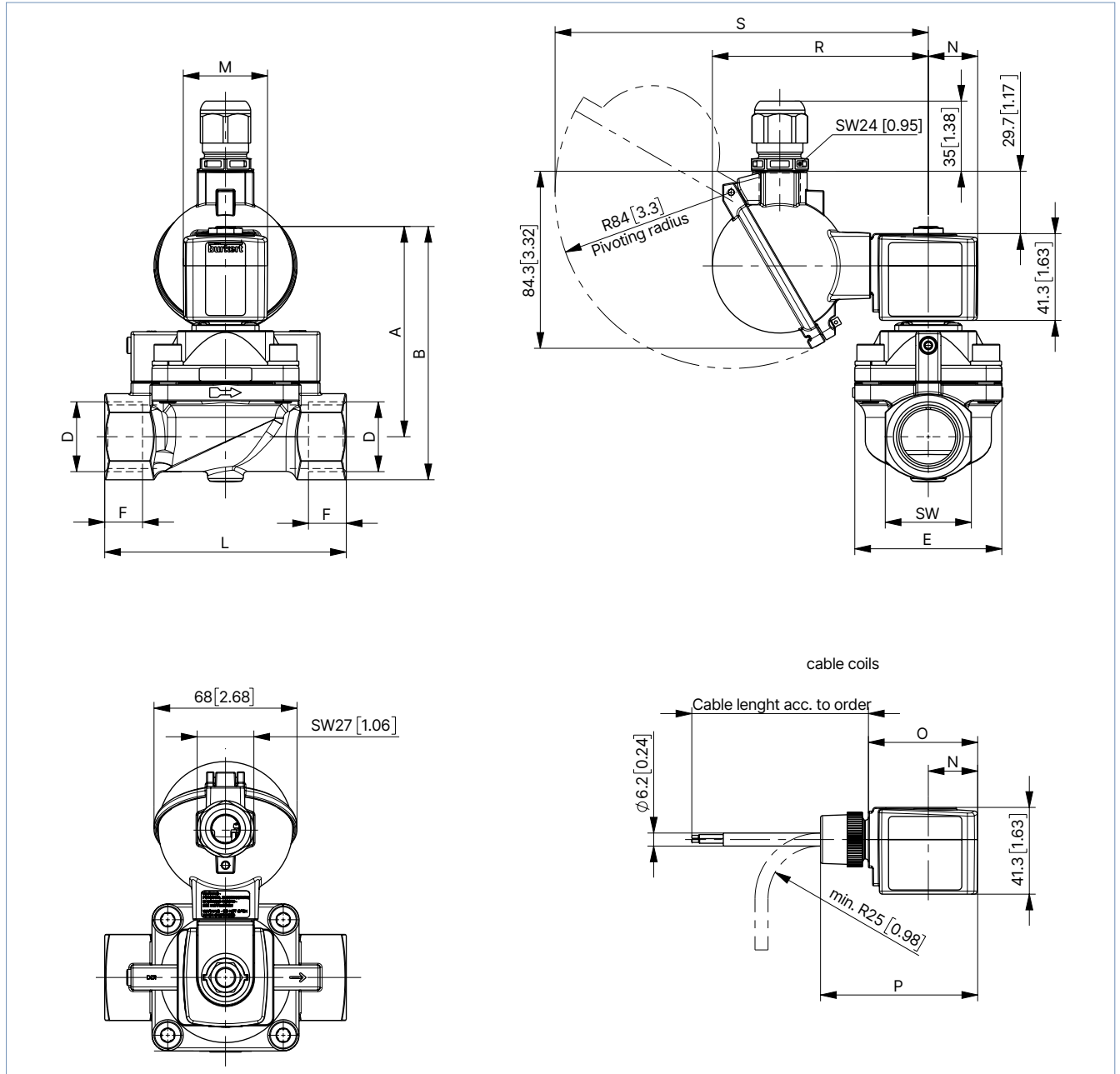

DTS 1000582645 EN Version: F Status: RL (released | freigegeben | valide) printed: 15.01.2026

Coil size	DN	CF A				CF B				G thread			NPT thread			Rc thread		
		A		B		A		B		D1	F1		D2	F2		D3	F3	
		[mm]	[in]	[mm]	[in]	[mm]	[in]	[mm]	[in]	[Zoll]	[mm]	[in]	[Zoll]	[mm]	[in]	[Zoll]	[mm]	[in]
5	12.0	83	3.27	96.5	3.80	90.8	3.57	104.3	4.11	G ½	14	0.55	NPT ½	13.7	0.54	Rc ½	13.2	0.52
	20.0	93	3.66	109	4.29	-	-	-	-	G ¾	16	0.63	NPT ¾	14	0.55	Rc ¾	14.5	0.57
	25.0	99.5	3.92	119	4.69	-	-	-	-	G 1	18	0.71	NPT 1	16.8	0.66	Rc 1	16.8	0.66
6	12.0	83	3.27	96.5	3.80	90.8	3.57	104.3	4.11	G ½	14	0.55	NPT ½	13.7	0.54	Rc ½	13.2	0.52
	20.0	93	3.66	109	4.29	-	-	-	-	G ¾	16	0.63	NPT ¾	14	0.55	Rc ¾	14.5	0.57
	25.0	99.5	3.92	119	4.69	-	-	-	-	G 1	18	0.71	NPT 1	16.8	0.66	Rc 1	16.8	0.66

Coil size	DN	E		L		SW		M		N		O		P		R		S	
		[mm]	[in]	[mm]	[in]	[mm]	[in]	[mm]	[in]	[mm]	[in]	[mm]	[in]	[mm]	[in]	[mm]	[in]	[mm]	[in]
5	12.0	33	1.30	65	2.56	27	1.06	32	1.26	20.5	0.81	46	1.81	68.8	2.71	99.8	3.93	174.7	6.88
	20.0	60	2.36	100	3.94	32	1.26												
	25.0	70	2.76	115	4.53	41	1.61												
6	12.0	33	1.30	65	2.56	27	1.06	40	1.57	23.5	0.93	52	2.05	74.8	2.94	102.8	4.05	177.7	7.00
	20.0	60	2.36	100	3.94	32	1.26												
	25.0	70	2.76	115	4.53	41	1.61												

6. Performance specifications

6.1. Temperature/duty cycle derating diagram for steam variant NA07

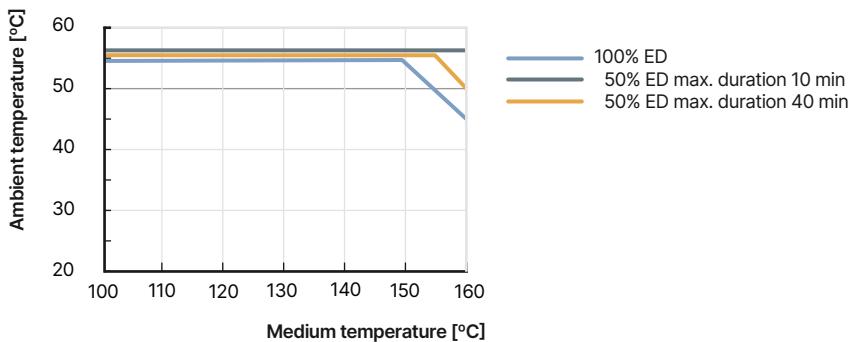

6.2. Characteristic values of intermittent operation

$$t_{SD} [s] = \frac{60}{SH \left(\frac{1}{min} \right)}$$

t_{SD} – Cycle time

$$t_{ED} [s] = \frac{ED [\%]}{100} \times t_{SD} [s]$$

t_{ED} – Duty cycle

$$t_{SP} [s] = t_{SD} [s] - t_{ED} [s]$$

t_{SP} – De-energized pause

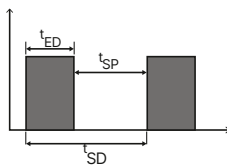

ED – Relative duty cycle relative

SH – Switching frequency

7. Product accessories

7.1. Special tool to turn the terminal box

Note:

Further information can be found in chapter [“Special tool to turn the terminal box” on page 31.](#)

8. Ordering information

8.1. Bürkert eShop



Bürkert eShop – Easy ordering and quick delivery

You want to find your desired Bürkert product or spare part quickly and order directly? Our online shop is available for you 24/7. Sign up and enjoy all the benefits.

[Order online now](#)

8.2. Bürkert product filter



Bürkert product filter – Get quickly to the right product

You want to select products comfortably based on your technical requirements? Use the Bürkert product filter and find suitable articles for your application quickly and easily.

[Try out our product filter](#)

8.3. Bürkert Product Enquiry Form

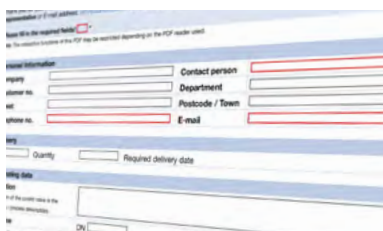

Bürkert Product Enquiry Form – Your enquiry quickly and compactly

Would you like to make a specific product enquiry based on your technical requirements? Use our Product Enquiry Form for this purpose. There you will find all the relevant information for your Bürkert contact. This will enable us to provide you with the best possible advice.

[Fill out the form now](#)

8.4. Ordering chart

Standard variant DN 12...DN 25, UL Recognized and CSA certified

Note:

- Please note that the cable plug **Type 2518** ▶ is included. UL Listed and other variants are available on request. For details see **"Cable plug Type 2518, form A according to DIN EN 175301 - 803" on page 31.**
- Further variants with alternative voltages, G or UN inner thread are available on request.

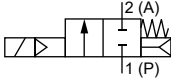
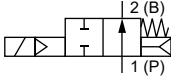
Circuit function	Port connection	Orifice	C _v value water	Pressure range (MAWP ^{1.)}	Article no.			
					024/DC 9 Watt	024/DC 10 Watt	024/60	120/60
		[mm]	[gal/min]	[psi]	[V/Hz]	[V/Hz]	[V/Hz]	[V/Hz]
Seal material PTFE/FKM								
CF A 2/2-way solenoid valve Servo-controlled Normally closed 	NPT 1/2	12	2.31	14.5...363	o. r.	–	–	–
				14.5...464	–	o. r.	o. r.	o. r.
	NPT 3/4	20	8.09	14.5...290	o. r.	o. r.	o. r.	o. r.
	NPT 1	25	11.56	14.5...290	o. r.	o. r.	o. r.	o. r.
CF B 2/2-way solenoid valve Servo-controlled Normally open 	NPT 1/2	12	2.31	14.5...464	–	o. r.	o. r.	o. r.
	NPT 3/4	20	8.09	14.5...290	–	o. r.	o. r.	o. r.
	NPT 1	25	11.56	14.5...290	–	o. r.	o. r.	o. r.

o. r. = on request
 – = not available
 1.) Maximum allowable working pressure

Standard variant DN 32...DN 50, UL Recognized and CSA certified

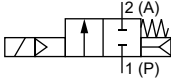
Circuit function	Port connection	Orifice	C _v value water	Pressure range (MAWP ^{1.)}	Article no.		
					024/DC	024/60	120/60
		[mm]	[gal/min]	[psi]	[V/Hz]	[V/Hz]	[V/Hz]
Seal material PTFE/FKM							
CF A 2/2-way solenoid valve Servo-controlled Normally closed 	NPT 1/4	32	20.81	14.5...232	o. r.	–	–
				14.5...290	–	o. r.	o. r.
	NPT 1/2	40	20.81	14.5...232	o. r.	–	–
				14.5...290	–	o. r.	o. r.
				14.5...145	o. r.	–	–
NPT 2	50	41.62	14.5...290	–	o. r.	o. r.	

o. r. = on request
 – = not available
 1.) Maximum allowable working pressure

DTS 1000582645 EN Version: F Status: RL (released | freigegeben | valide) printed: 15.01.2026

Standard variant DN 12...DN 25, UL Listed and CSA certified

Note:

- Please note that the cable plug **Type 2509** ▶ is included. UL Listed and other variants are available on request. For details see “**Cable plug Type 2509, form A according to DIN EN 175301 - 803**” on page 31.
- Further variants with alternative voltages, G or UN inner thread are available on request.

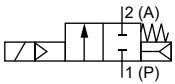
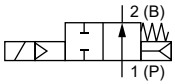
Circuit function	Port connection	Orifice [mm]	C _v value water [gal/min]	Pressure range (MAWP ^{1.)} [psi]	Article no.			
					024/DC 9 Watt [V/Hz]	024/DC 10 Watt [V/Hz]	024/60 [V/Hz]	120/60 [V/Hz]
Seal material PTFE/FKM								
CF A 2/2-way solenoid valve Servo-controlled Normally closed 	NPT 1/2	12	2.31	14.5...363	o. r.	–	–	–
				14.5...464	–	o. r.	o. r.	o. r.
	NPT 3/4	20	8.09	14.5...290	o. r.	o. r.	o. r.	o. r.
	NPT 1	25	11.56	14.5...290	o. r.	o. r.	o. r.	o. r.
CF B 2/2-way solenoid valve Servo-controlled Normally open 	NPT 1/2	12	2.31	14.5...464	–	o. r.	o. r.	o. r.
	NPT 3/4	20	8.09	14.5...290	–	o. r.	o. r.	o. r.
	NPT 1	25	11.56	14.5...290	–	o. r.	o. r.	o. r.

o. r. = on request
 – = not available
 1.) Maximum allowable working pressure

Standard variant DN 32...DN 50, UL Listed and CSA certified

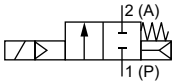
Circuit function	Port connection	Orifice [mm]	C _v value water [gal/min]	Pressure range (MAWP ^{1.)} [psi]	Article no.		
					024/DC [V/Hz]	024/60 [V/Hz]	120/60 [V/Hz]
Seal material PTFE/FKM							
CF A 2/2-way solenoid valve Servo-controlled Normally closed 	NPT 1/4	32	20.81	14.5...232	o. r.	–	–
				14.5...290	–	o. r.	o. r.
	NPT 1/2	40	20.81	14.5...232	o. r.	–	–
				14.5...290	–	o. r.	o. r.
	NPT 2	50	41.62	14.5...145	o. r.	–	–
			14.5...290	–	o. r.	o. r.	

o. r. = on request
 – = not available
 1.) Maximum allowable working pressure

DTS 1000582645 EN Version: F Status: RL (released | freigegeben | valide) printed: 15.01.2026

Steam variant NA07, DN 13...DN 40, UL Recognized with coil UL Recognized (cURus)

Note:

- Please note that the cable plug **Type 2518** is included. UL Listed and other variants are available on request. For details see [“Cable plug Type 2518, form A according to DIN EN 175301-803” on page 31.](#)
- Due to the temperature range, the cable plug with silicone seal is provided for steam variants NA07.
- Please also note the derating diagram, see [“6.1. Temperature/duty cycle derating diagram for steam variant NA07” on page 22.](#)
- Further variants with alternative voltages, G or UN inner thread and higher medium temperature are available on request.

Circuit function	Port connection	Orifice [mm]	C _v value water [gal/min]	Pressure range (MAWP ¹⁾ [psi]	Max. medium temperature [°F]	Article no.			
						024/DC [V/Hz]	024/60 [V/Hz]	120/60 [V/Hz]	240/60 [V/Hz]
Seal material PTFE/graphite									
CF A 2/2-way solenoid valve Servo-controlled Normally closed 	NPT 1/2	13	4.28	14.5...73	302	00342015	–	–	–
				14.5...174		–	00466912	00466911	o. r.
	NPT 3/4	20	8.09	14.5...73	302	00466918	–	–	–
				14.5...174		–	00342016	00342017	o. r.
	NPT 1	25	11.56	14.5...73	302	00342018	–	–	–
				14.5...174		–	00342019	00342020	o. r.
	NPT 1 1/4	32	20.81	14.5...58	302	00342021	–	–	–
				14.5...174		–	00342022	00467419	o. r.
	NPT 1 1/2	40	20.81	14.5...58	302	00326598	–	–	–
				14.5...174		–	00342023	00467420	o. r.

o. r. = on request
 – = not available
 1.) Maximum allowable working pressure

Steam variant NA07, DN 13...DN 40, UL Listed with coil UL Recognized (cURus)

Note:

- Please note that the cable plug **Type 2509** is included. UL Listed and other variants are available on request. For details see [“Cable plug Type 2509, form A according to DIN EN 175301-803” on page 31.](#)
- Please also note the derating diagram, see [“6.1. Temperature/duty cycle derating diagram for steam variant NA07” on page 22.](#)
- Further variants with alternative voltages, G or UN inner thread and higher medium temperature are available on request.

Circuit function	Port connection	Orifice [mm]	C _v value water [gal/min]	Pressure range (MAWP ¹⁾ [psi]	Max. medium temperature [°F]	Article no.			
						024/DC [V/Hz]	024/60 [V/Hz]	120/60 [V/Hz]	240/60 [V/Hz]
Seal material PTFE/graphite									
CF A 2/2-way solenoid valve Servo-controlled Normally closed 	NPT 1/2	13	4.28	14.5...73	302	o. r.	–	–	–
				14.5...174		–	o. r.	o. r.	o. r.
	NPT 3/4	20	8.09	14.5...73	302	o. r.	–	–	–
				14.5...174		–	o. r.	o. r.	o. r.
	NPT 1	25	11.56	14.5...73	302	o. r.	–	–	–
				14.5...174		–	o. r.	o. r.	o. r.
	NPT 1 1/4	32	20.81	14.5...58	302	o. r.	–	–	–
				14.5...174		–	o. r.	o. r.	o. r.
	NPT 1 1/2	40	20.81	14.5...58	302	o. r.	–	–	–
				14.5...174		–	o. r.	o. r.	o. r.

o. r. = on request
 – = not available
 1.) Maximum allowable working pressure

DTS 1000582645 EN Version: F Status: RL (released | freigegeben | valide) printed: 15.01.2026

Fire Protection service valve, UL Recognized with Fire Protection / UL Listed with Fire Protection

Note:

- Please note that for UL recognized variant the cable plug **Type 2518** ▶ is included. UL Listed and other variants are available on request. For details see [“Cable plug Type 2518, form A according to DIN EN 175301-803” on page 31.](#)
- Please note that for UL listed variant the cable plug **Type 2509** ▶ is included. For details see [“Cable plug Type 2509, form A according to DIN EN 175301-803” on page 31.](#)
- Further variants with G inner thread are available on request.

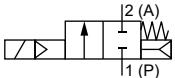
Circuit function	Port connection	Orifice	C _v value water	Pressure range (MAWP ^{1.)})	Medium temp. range	Ambient temp. range	Certification	Article no.	
								024/DC	024/56
		[mm]	[gal/min]	[psi]	[°F]	[°F]		[V/Hz]	[V/Hz]
Seal material PTFE/graphite									
CF A 2/2-way solenoid valve Servo-controlled Normally closed 	NPT 1/2	12	2.31	14.5...363	41...194	41...131	UL recognized	o. r.	o. r.
							UL listed	00324566 ☞	o. r.

o. r. = on request

1.) Maximum allowable working pressure

High pressure variant up to 1160 psi (PN 08), coil UL Recognized (cURus)

Note:

- Please note that the cable plug **Type 2518** ▶ is included. UL Listed and other variants are available on request. For details see [“Cable plug Type 2518, form A according to DIN EN 175301-803” on page 31.](#)
- Please note: fluids and high differential pressure may cause high pressure surges.

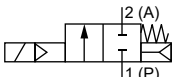
Circuit function	Port connection	Orifice	C _v value water	Pressure range (MAWP ^{1.)})	Article no.			
					024/DC	024/60	120/60	240/60
		[mm]	[gal/min]	[psi]	[V/Hz]	[V/Hz]	[V/Hz]	[V/Hz]
Seal material PTFE/FKM								
CF A 2/2-way solenoid valve Servo-controlled Normally closed 	NPT 1/2	12	2.31	14.5...1160	o. r.	o. r.	o. r.	o. r.

o. r. = on request

1.) Maximum allowable working pressure

DTS 1000582645 EN Version: F Status: RL (released | freigegeben | valide) printed: 15.01.2026

Discharge valve for compressor systems (CF05), UL Recognized and CSA certified

Note:

- Please note that the cable plug **Type 2518** ▶ is included. UL Listed and other variants are available on request. For details see [“Cable plug Type 2518, form A according to DIN EN 175301 - 803” on page 31.](#)
- Further variants with alternative voltages and G inner thread are available on request.

Circuit function	Port connection	Orifice [mm]	C _v value water [gal/min]	Pressure range (MAWP ^{1.)} [psi]	Article no.		
					024/DC [V/Hz]	024/60 [V/Hz]	120/60 [V/Hz]
CF B 2/2-way solenoid valve Servo-controlled Normally open 	NPT ½	12	2.31	14.5...464	o. r.	o. r.	o. r.

o. r. = on request

1.) Maximum allowable working pressure

Discharge valve for compressor systems (CF05), UL Listed and CSA certified

Note:

- Please note that for UL listed variant the cable plug **Type 2509** ▶ is included. For details see [“Cable plug Type 2509, form A according to DIN EN 175301 - 803” on page 31.](#)
- Further variants with alternative voltages and G inner thread are available on request.

Circuit function	Port connection	Orifice [mm]	C _v value water [gal/min]	Pressure range (MAWP ^{1.)} [psi]	Article no.		
					024/DC [V/Hz]	024/60 [V/Hz]	120/60 [V/Hz]
CF B 2/2-way solenoid valve Servo-controlled Normally open 	NPT ½	12	2.31	14.5...464	o. r.	o. r.	o. r.

o. r. = on request

1.) Maximum allowable working pressure

DTS 1000582645 EN Version: F Status: RL (released | freigegeben | valide) printed: 15.01.2026

Coil UL Listed (cULus) for hazardous locations, Class I, Division 2 cable variant

Note:

- Further variants with G inner thread on request.
- With 3 m/9'10" cable as standard. Other lengths on request.

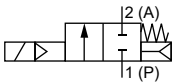
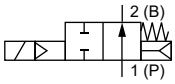
Circuit function	Port connection	Orifice	C _v value water	Pressure range (MAWP ^{1.)})		Article no.			
				Liquids	Gases	12 / AC/DC	24 / AC/DC	120 / AC	240 / AC
				[mm]	[gal/min]	[psi]	[psi]	[V/Hz]	[V/Hz]
Seal material PTFE/FKM									
CF A 2/2-way solenoid valve Servo-controlled Normally closed 	NPT 1/2	12	2.31	14.5...725	14.5...725	o. r.	o. r.	o. r.	o. r.
	NPT 3/4	20	8.09	14.5...362	14.5...464	o. r.	o. r.	o. r.	o. r.
	NPT 1	25	11.56	14.5...362	14.5...464	o. r.	20027923 𐀀	o. r.	o. r.
CF B 2/2-way solenoid valve Servo-controlled Normally open 	NPT 1/2	12	2.31	14.5...464	14.5...464	o. r.	o. r.	o. r.	o. r.
	NPT 3/4	20	8.09	14.5...362	14.5...362	o. r.	o. r.	o. r.	o. r.
	NPT 1	25	11.56	14.5...362	14.5...362	o. r.	o. r.	o. r.	o. r.

o. r. = on request

1.) Maximum allowable working pressure

Labeling explosion protection cable coil	
NEC 500	Class I, Division 2, Groups A,B,C,D T4 Class I,II, Division 2, Groups F,G T4
NEC 505	Class I, Zone 1, AEx mb IIC T4 Gb
CEC 18	Zone 21, AEx mb IIC T275 °F Db

DTS 1000582645 EN Version: F Status: RL (released | freigegeben | valide) printed: 15.01.2026

Coil UL Listed (cULus) for hazardous locations, Class I, Division 2 terminal box variant

Note:



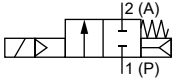
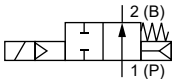

Further variants with G inner thread on request.

Circuit function	Port connection	Orifice [mm]	C _v value water [gal/min]	Pressure range (MAWP ^{1.)}		Article no.			
				Liquids [psi]	Gases [psi]	12 / AC/DC [V/Hz]	24 / AC/DC [V/Hz]	120 / AC [V/Hz]	240 / AC [V/Hz]
				Seal material PTFE/FKM					
CF A 2/2-way solenoid valve Servo-controlled Normally closed 	NPT 1/2	12	2.31	14.5...725	14.5...725	o. r.	o. r.	o. r.	o. r.
	NPT 3/4	20	8.09	14.5...362	14.5...464	o. r.	o. r.	o. r.	o. r.
	NPT 1	25	11.56	14.5...362	14.5...464	o. r.	o. r.	o. r.	o. r.
CF B 2/2-way solenoid valve Servo-controlled Normally open 	NPT 1/2	12	2.31	14.5...464	14.5...464	o. r.	o. r.	o. r.	o. r.
	NPT 3/4	20	8.09	14.5...362	14.5...362	o. r.	o. r.	o. r.	o. r.
	NPT 1	25	11.56	14.5...362	14.5...362	o. r.	o. r.	o. r.	o. r.

o. r. = on request

1.) Maximum allowable working pressure

Labeling explosion protection terminal box	
NEC 500	Class I, Division 2, Groups A,B,C,D T4 Class I,II, Division 2, Groups F,G T4
NEC 505 CEC 18	Class I, Zone 1, AEx eb mb IIC T4 Gb Zone 21, AEx mb tb IIC T275 °F Db

Further variants on request	
 Approval Further information can be found in chapter "3. Approvals and conformities" on page 5.	 Temperature Special temperature ranges
 Process connection <ul style="list-style-type: none"> G UN 	 Voltage 110/50, further voltages on request

DTS 1000582645 EN Version: F Status: RL (released | freigegeben | valide) printed: 15.01.2026

8.5. Ordering chart accessories

Cable plug Type 2509, form A according to DIN EN 175301 - 803

Note:

- Dimensions in mm
- Without wiring (standard)
- The cable plug Type 2509 meets the requirements of UL hazloc Div. 2.
- The cable plug Type 2509 meets the requirements of UL Listed (UL 429) in assembly with a Bürkert solenoid valve.
- Refer to data sheet **Type 2509** ▶ for more information about the cable plug.

Cable plug	Dimensions	Variant	Voltage	Article no.
		Without wiring	0...250 V AC/DC	137943 𐀀

Cable plug Type 2518, form A according to DIN EN 175301 - 803

Note:

- Dimensions in mm
- For further variants see data sheet **Type 2518** ▶.

Cable plug	Dimensions	Variant	Voltage	Article no.
		Without wiring (AC/DC)	0...250 V AC/DC	314802 𐀀
		With LED (AC/DC)	12...24 V AC/DC	314812 𐀀
		With LED and varistor (AC/DC)	12...24 V AC/DC	314820 𐀀
		With rectifier, LED and varistor	12...24 V AC/DC	314816 𐀀
		Without wiring (AC/DC) with silicone seal for higher ambient temperature, e.g. steam variant (NA07)	0...250 V AC/DC	361687 𐀀

Special tool to turn the terminal box

Note:

This special tool is not supplied with the valve.

Description	Components of the set	Article no.
Set SC02-AC10	<ul style="list-style-type: none"> • Special tool • Service manual 	293488 𐀀

DTS 1000582645 EN Version: F Status: RL (released | freigegeben | valide) printed: 15.01.2026