





Servo-assisted 2/2-way diaphragm valve

- Servo-assisted diaphragm valve up to DN65 orifice
- Separating diaphragm for aggressive and contaminated media
- Closing and opening times can be adjusted individually
- Explosion-proof variants (Cat. 2)
- Service-friendly manual override

Product variants described in the data sheet may differ from the product presentation and description.

Can be combined with

	Type 2518 Cable plug, form A according to DIN EN 175301-803	▶
	Type 1087 Timer, form A according to DIN EN 175301-803	▶
	Type 2509 Cable plug, form A according to DIN EN 175301-803	▶

Type description

The 5282 valve is a servo-assisted diaphragm valve. A minimum differential pressure is required for the valve to function. Various diaphragm material combinations and circuit functions are available depending on the application. The standard brass body satisfies all European drinking water requirements. The body offering is completed with stainless steel variants. The 3/2-way pilot valve can be easily converted from NC to NO circuit function by rotating it on the armature. The solenoid coils are moulded with a chemically resistant epoxy. The 5282 is equipped with manual override for start-up and testing. NEMA 4X is available on request.

DTS 1000082431 EN Version: M Status: RL (released | freigegeben | valide) printed: 26.02.2026

Table of contents

1. General technical data	3
2. Circuit functions	4
3. Approvals and conformities	4
3.1. General notes	4
3.2. Conformity	4
3.3. Standards	4
3.4. Explosion protection	5
3.5. North America (USA/Canada)	5
3.6. Drinking water	5
3.7. Others	6
DNV GL classification	6
4. Materials	6
4.1. Bürkert resistApp	6
4.2. Material specifications	6
5. Dimensions	7
5.1. Standard variant	7
Threaded variant	7
5.2. ATEX/IECEx variant – coil UL Listed (cULus) for hazardous locations, Class I, Division 2	8
Threaded variant	8
6. Product installation	10
6.1. Mounting options	10
7. Product accessories	10
7.1. Cable glands for ATEX/IECEx terminal box	10
7.2. Special tool to turn the terminal box	11
8. Ordering information	11
8.1. Bürkert eShop	11
8.2. Bürkert product filter	11
8.3. Bürkert Product Enquiry Form	11
8.4. Ordering chart	12
Basic variant with coil UL recognized (cURus)	12
UL Recognized & CSA approval – Brass body	13
UL Recognized & CSA approval – Stainless steel body	14
UL Listed – Brass body	15
UL Listed – Stainless steel body	16
ATEX/IECEx variant – coil UL Listed (cULus) for hazardous locations, Class I, Division 2	17
8.5. Ordering chart accessories	18
Cable plug Type 2518, form A according to DIN EN 175301 - 803	18
Cable plug Type 2509, form A according to DIN EN 175301 - 803	18
Cable glands for ATEX/IECEx terminal box	18

1. General technical data

Product properties	
Dimensions	Further information can be found in chapter "5. Dimensions" on page 7.
Material	
Seal	NBR, EPDM, FKM
Flange body	Stainless steel 1.4581/316CB
Threaded body	Brass CW617 N DN 13 stainless steel CF3M DN 20...DN 50 stainless steel 1.4581/316CB
Coil	Epoxy
Internal valve parts	Stainless steel, brass
Orifice	DN 13...DN 65
Circuit function	A and B Further information can be found in chapter "2. Circuit functions" on page 4.
Thermal insulation class of solenoid coil	Epoxy coil class H
Performance data	
Duty cycle	100 % continuous operation
Switching time ¹⁾	Opening: 0.1...0.8 s Closing: 1.0...4.0 s
Electrical data	
Operating voltage	24 V DC, 24 V 56 Hz, 120 V 60 Hz, 230 V 56 Hz, 240 V 60 Hz, 24 V AC/DC, 230 V AC/DC
Power consumption	
Standard variant	Inrush: AC 30 VA Operation: AC 15/8 VA W DC cold/warm: 11/8 W
Explosion-proof variant	Inrush: AC 40 VA Operation: AC 3 VA W DC cold/warm: 40 W inrush / 3 W operation
Voltage tolerance	± 10 %
Medium data	
Operating medium	
With NBR	Neutral gases and liquids (e.g. compressed air, water, hydraulic oil)
With EPDM	Oil-free and grease-free media, alkalis, hot water
With FKM	Hot air, per solutions, hot oils
Medium temperature	
With NBR	+ 32 °F...+ 176 °F
With EPDM	- 13 °F...+ 194 °F
With FKM	+ 32 °F...+ 194 °F
Product connections	
Electrical connection	
Standard variant	<ul style="list-style-type: none"> Cable plug Type 2518 ▶, form A according to DIN EN 175301 - 803 Further information can be found in chapter "Cable plug Type 2518, form A according to DIN EN 175301 - 803" on page 18. Cable plug Type 2509 ▶, form A according to DIN EN 175301 - 803 Further information can be found in chapter "Cable plug Type 2509, form A according to DIN EN 175301 - 803" on page 18.
Explosion-proof variant	Moulded 3 meter cable, 3 × 0.5 mm ² Terminal box
Approvals and conformities	
Directive	CE, EAC
Degree of protection	IP65 with cable plug according to DIN EN 175301 - 803 form A IP65 with cable connection or terminal box
Explosion protection	Further information can be found in chapter "3.4. Explosion protection" on page 5.
North America (USA/Canada)	Further information can be found in chapter "3.5. North America (USA/Canada)" on page 5.
Others	Further information can be found in chapter "3.7. Others" on page 6.

Environment and installation

Installation position	As required, preferably with actuator upright
Ambient temperature	Max. + 131 °F

1.) Measurement at + 68 °F, 87 psi at the valve outlet, opening: pressure build-up 0...90 %, closing: pressure reduction 100...10 %
 The switching time can be changed by turning the throttle screws (in the housing lid).

2. Circuit functions

Symbol	Description
	Circuit function A (CF A) 2/2-way solenoid valve Servo-controlled Normally closed
	Circuit function A (CF A) 2/2-way solenoid valve Servo-controlled, with manual override Normally closed
	Circuit function B (CF B) 2/2-way solenoid valve Servo-controlled Normally open
	Circuit function B (CF B) 2/2-way solenoid valve Servo-controlled, with manual override Normally open

3. Approvals and conformities

3.1. General notes

- The approvals and conformities listed below must be stated when making enquiries. This is the only way to ensure that the product complies with all required specifications.
- Not all available variants can be supplied with the below mentioned approvals or conformities.

3.2. Conformity



In accordance with the Declaration of Conformity, the product is compliant with the EU Directives.

3.3. Standards





The applied standards which are used to demonstrate compliance with the EU Directives are listed in the EU-Type Examination Certificate and/or the EU Declaration of Conformity.

DTS 1000082431 EN Version: M Status: RL (released | freigegeben | valide) printed: 26.02.2026

3.4. Explosion protection

Approval	Description					
 	<p>Optional: Explosion protection according to category 2 (zone 1/21)</p> <p>Ex marking of the components according to the following table:</p>					
	<table border="1"> <thead> <tr> <th colspan="2">Coil Type ACP016</th> </tr> <tr> <th>Coils with cable outlet</th> <th>Coils with terminal box</th> </tr> </thead> <tbody> <tr> <td> <p>ATEX: EPS 16 ATEX 1 111 X II 2 G Ex mb IIC T4 Gb II 2 D Ex mb IIIC T130 °C Db</p> <p>IECEX: IECEX EPS 16.0049X Ex mb IIC T4 Gb Ex mb IIIC T130 °C Db</p> </td> <td> <p>ATEX: EPS 16 ATEX 1 111 X II 2G Ex eb mb IIC T4 Gb II 2D Ex mb tb IIIC T130 °C Db</p> <p>IECEX: IECEX EPS 16.0049X Ex eb mb IIC T4 Gb Ex mb tb IIIC T130 °C Db</p> </td> </tr> </tbody> </table>	Coil Type ACP016		Coils with cable outlet	Coils with terminal box	<p>ATEX: EPS 16 ATEX 1 111 X II 2 G Ex mb IIC T4 Gb II 2 D Ex mb IIIC T130 °C Db</p> <p>IECEX: IECEX EPS 16.0049X Ex mb IIC T4 Gb Ex mb IIIC T130 °C Db</p>
Coil Type ACP016						
Coils with cable outlet	Coils with terminal box					
<p>ATEX: EPS 16 ATEX 1 111 X II 2 G Ex mb IIC T4 Gb II 2 D Ex mb IIIC T130 °C Db</p> <p>IECEX: IECEX EPS 16.0049X Ex mb IIC T4 Gb Ex mb IIIC T130 °C Db</p>	<p>ATEX: EPS 16 ATEX 1 111 X II 2G Ex eb mb IIC T4 Gb II 2D Ex mb tb IIIC T130 °C Db</p> <p>IECEX: IECEX EPS 16.0049X Ex eb mb IIC T4 Gb Ex mb tb IIIC T130 °C Db</p>					

3.5. North America (USA/Canada)

Approval	Description
	<p>Valid for valves: UL Listed for the USA The valves are UL Listed for the USA according to:</p> <ul style="list-style-type: none"> UL 429 (electrically operated valves) and UL 429A (Electrically Operated Valves for Fire Protection Service)
	<p>Valid for coils: UL Hazardous Locations – Explosion Protection UL Listed for Hazardous Locations for USA and Canada Class I, Zone 1 Class I, Division 2, Group A, B, C and D Class II + III, Division 2, Group F and G</p>
	<p>Valid for valves: UL Recognized for the USA The valves are UL Recognized for the USA according to:</p> <ul style="list-style-type: none"> UL 429 (electrically operated valves) and UL 429A (Electrically Operated Valves for Fire Protection Service)
	<p>Valid for valves: CSA for Canada The valves are CSA approved for Canada according to:</p> <ul style="list-style-type: none"> CSA 139 (electrically operated valves)
	<p>Valid for coils: FM (Factory Mutual) – Explosion Protection FM for Hazardous Locations for USA and Canada Class I, Zone 1 Class I, Division 1, Groups A, B, C and D Class II + III, Division 1, Groups E, F and G</p>

3.6. Drinking water

Conformity	Description
	<p>Suitable for use in drinking water applications The materials comply with the assessment principles (UBA) for materials in contact with drinking water (TrinkwasserV).</p> <p>PF39: Suitable for products with a maximum temperature of + 85 °C (hot water) PF36: Suitable for products with a maximum temperature of + 60 °C (warm water)</p>

DTS 1000082431 EN Version: M Status: RL (released | freigegeben | valide) printed: 26.02.2026

3.7. Others

DNV GL classification

Approval	Description
	DNV GL classification – Ships, offshore units, and high speed and light craft The products are accepted for installation on all vessels classed by DNV GL.

4. Materials

4.1. Bürkert resistApp

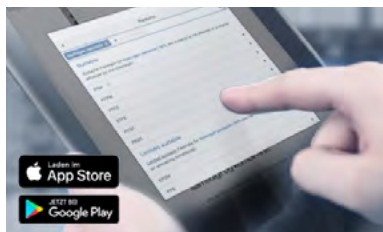

Bürkert resistApp – Chemical resistance chart

You want to ensure the reliability and durability of the materials in your individual application case? Verify your combination of media and materials on our website or in our resistApp.

[Start chemical resistance check](#)

4.2. Material specifications

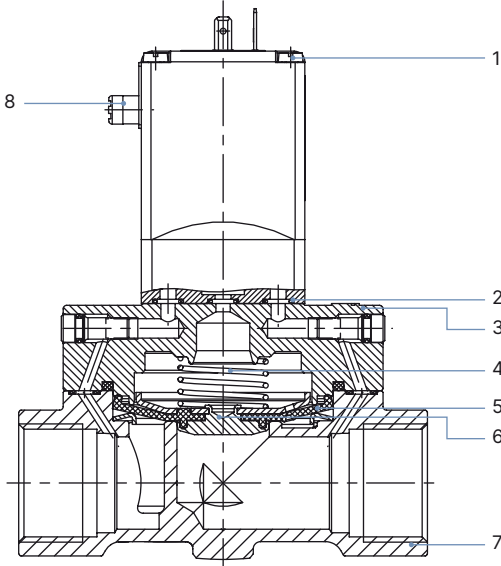

No.	Element	Material
1	Coil	Epoxy
2	O-ring	NBR, EPDM, FKM
3	Cover	Brass DN 13 stainless steel 1.4408/316 DN 20...DN 50 stainless steel 1.4581/316CB
4	Spring	Stainless steel 1.4310/302
5	Diaphragm	NBR, EPDM, FKM
6	Diaphragm holder	Brass, stainless steel 1.4401/316
7	Valve body	Brass DN 13 stainless steel CF3M DN 20...DN 50 stainless steel 1.4581/316CB
8	Manual override	PA

DTS 1000082431 EN Version: M Status: RL (released | freigegeben | valide) printed: 26.02.2026

5. Dimensions

5.1. Standard variant

Threaded variant

Note:

Dimensions in mm [inch]

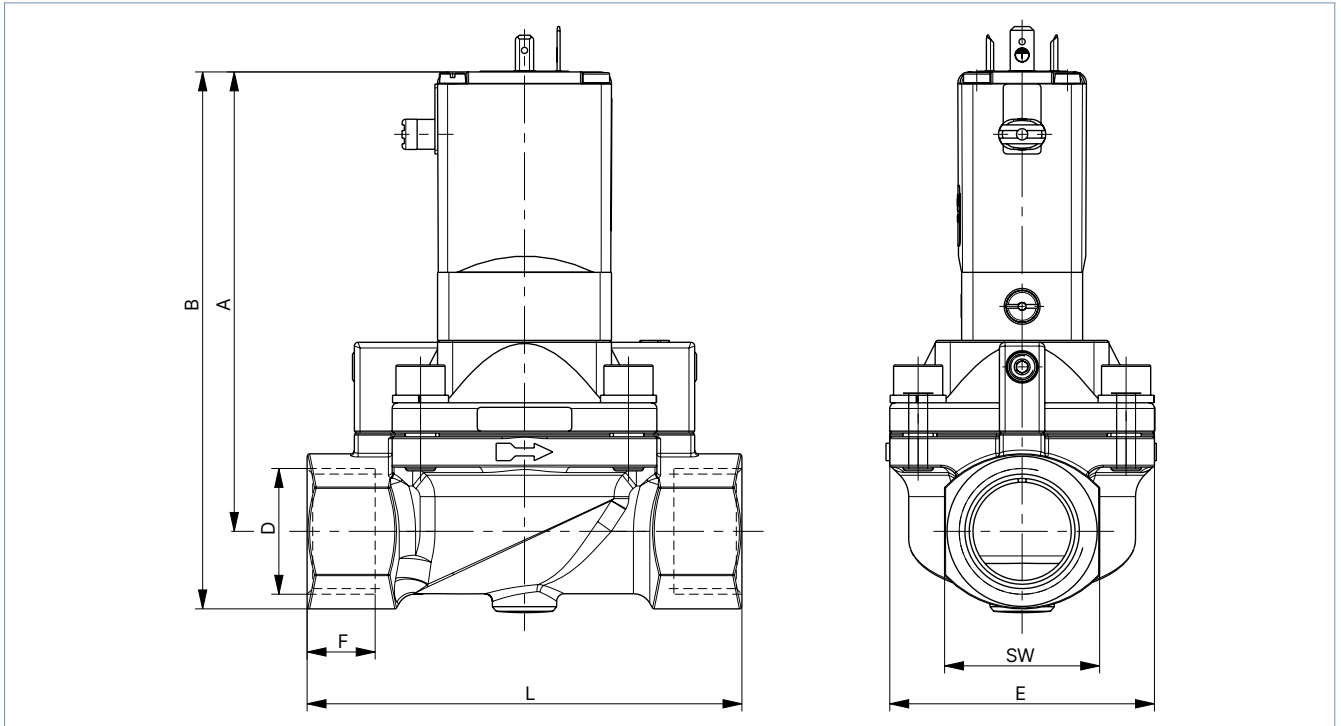

Body material	DN	A		B		D [Zoll]	F		E		L		SW	
		[mm]	[in]	[mm]	[in]		[mm]	[in]	[mm]	[in]	[mm]	[in]	[mm]	[in]
Brass	13	109	4.29	123	4.84	NPT ½	13.7	0.54	40	1.57	65	2.56	27	1.06
	20	115	4.53	131	5.16	NPT ¾	14	0.55	60	2.36	100	3.94	32	1.26
	25	121.5	4.78	142	5.59	NPT 1	16.8	0.66	70	2.76	115	4.53	41	1.61
	32	122	4.80	147	5.79	NPT 1¼	17.3	0.68	85	3.35	126	4.96	50	1.97
	40	126	4.96	156.5	6.16	NPT 1½	17.3	0.68	85	3.35	126	4.96	60	2.36
	50	142.5	5.61	177.5	6.99	NPT 2	17.6	0.69	115	4.53	164	6.46	70	2.76
	65	142.5	5.61	185	7.28	NPT 2½	23.6	0.93	115	4.53	180	7.09	85	3.35
Stainless steel	13	108	4.25	124	4.88	NPT ½	13.7	0.54	40	1.57	65	2.56	32	1.26
						NPT ¾	14	0.55						
	20	115	4.53	131	5.16	NPT ½	13.7	0.54	60	2.36	100	3.94	32	1.26
						NPT ¾	14	0.55						
	25	121.5	4.78	142	5.59	NPT 1	16.8	0.66	70	2.76	115	4.53	41	1.61
	32	122	4.80	147	5.79	NPT 1¼	17.3	0.68	85	3.35	126	4.96	50	1.97
	40	126	4.96	156.5	6.16	NPT 1½	17.3	0.68	85	3.35	126	4.96	60	2.36
50	142.5	5.61	177.5	6.99	NPT 2	17.6	0.69	115	4.53	164	6.46	70	2.76	
65	142.5	5.61	185	7.28	NPT 2½	23.6	0.93	115	4.53	180	7.09	85	3.35	

DTS 1000082431 EN Version: M Status: RL (released | freigegeben | valide) printed: 26.02.2026

5.2. ATEX/IECEx variant – coil UL Listed (cULus) for hazardous locations, Class I, Division 2

Threaded variant

Note:

Dimensions in mm [inch]

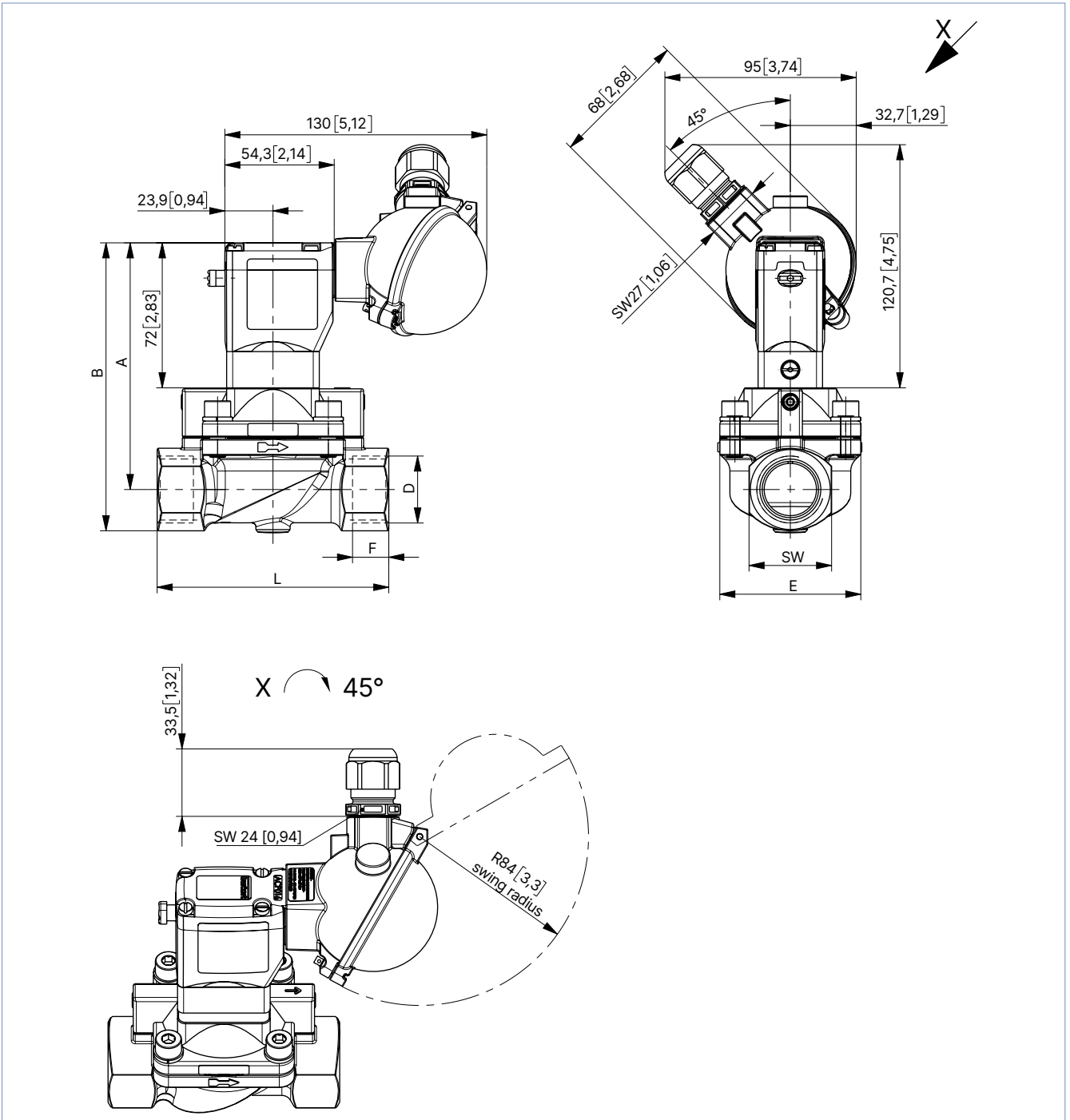

DTS 1000082431 EN Version: M Status: RL (released | freigegeben | valide) printed: 26.02.2026

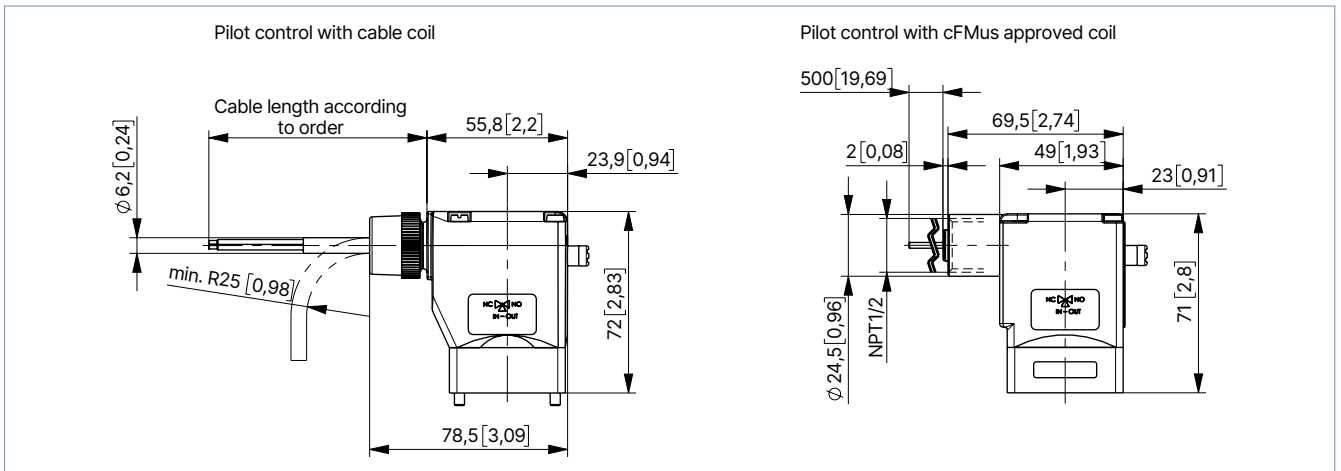

Body material	DN	A		B		D [Zoll]	F		E		L		SW	
		[mm]	[in]	[mm]	[in]		[mm]	[in]	[mm]	[in]	[mm]	[in]	[mm]	[in]
Brass	13	110	4.33	124	4.88	NPT 1/2	13.7	0.54	40	1.57	65	2.56	27	1.06
	20	116	4.57	132	5.20	NPT 3/4	14	0.55	60	2.36	100	3.94	32	1.26
	25	122.5	4.82	143	5.63	NPT 1	16.8	0.66	70	2.76	115	4.53	41	1.61
	32	123	4.84	148	5.83	NPT 1 1/4	17.3	0.68	85	3.35	126	4.96	50	1.97
	40	127	5.00	157	6.18	NPT 1 1/2	17.3	0.68	85	3.35	126	4.96	60	2.36
	50	143.8	5.66	178.8	7.04	NPT 2	17.6	0.69	115	4.53	164	6.46	70	2.76
	65	143.5	5.65	186	7.32	NPT 2 1/2	23.6	0.93	115	4.53	180	7.09	85	3.35
Stainless steel	13	109	4.29	125	4.92	NPT 1/2	13.7	0.54	40	1.57	65	2.56	32	1.26
						NPT 3/4	14	0.55						
	20	116	4.57	132	5.20	NPT 1/2	13.7	0.54	60	2.36	100	3.94	32	1.26
						NPT 3/4	14	0.55						
	25	122.5	4.82	143	5.63	NPT 1	16.8	0.66	70	2.76	115	4.53	41	1.61
	32	123	4.84	148	5.83	NPT 1 1/4	17.3	0.68	85	3.35	126	4.96	50	1.97
	40	127	5.00	157	6.18	NPT 1 1/2	17.3	0.68	85	3.35	126	4.96	60	2.36
50	143.8	5.66	178.8	7.04	NPT 2	17.6	0.69	115	4.53	164	6.46	70	2.76	
65	143.5	5.65	186	7.32	NPT 2 1/2	23.6	0.93	115	4.53	180	7.09	85	3.35	

DTS 1000082431 EN Version: M Status: RL (released | freigegeben | valide) printed: 26.02.2026

6. Product installation

6.1. Mounting options

Note:

- The delivery condition corresponds to the order key. Turning the pilot valve through 180° changes the circuit function of the valve.
- The circuit function can only be changed for variants up to 145 psi.

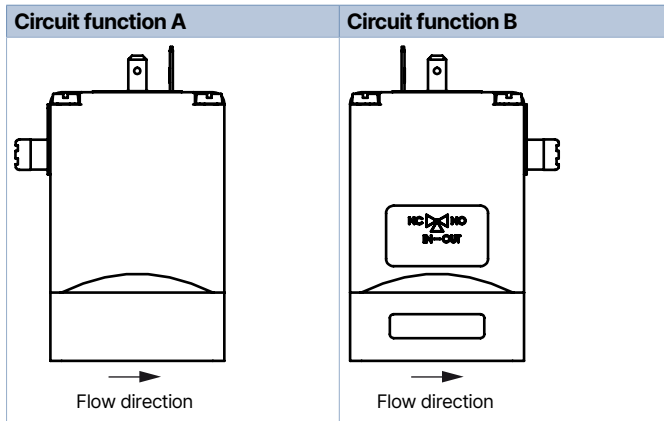

7. Product accessories

7.1. Cable glands for ATEX/IECEx terminal box

Note:

A polyamide cable gland is included in the scope of delivery. A nickel-plated brass variant can be ordered for a surcharge, see **"8.5. Ordering chart accessories"** on page 18.

Description	Ex approval		Dimensions										
	Certification	Identification											
Ex cable gland, nickel-plated brass, 6...13 mm 	PTB 04 ATEX 1112 X, IECEx PTB 13.0027X	II 2 G Ex e IIC Gb, II 2 D Ex tb IIIC Db IP68	<table border="1"> <tr><td>TL</td><td>29...37 mm</td></tr> <tr><td>L</td><td>6 mm</td></tr> <tr><td>D</td><td>20 mm</td></tr> <tr><td>SW</td><td>24 mm</td></tr> <tr><td>E</td><td>27 mm</td></tr> </table>	TL	29...37 mm	L	6 mm	D	20 mm	SW	24 mm	E	27 mm
TL	29...37 mm												
L	6 mm												
D	20 mm												
SW	24 mm												
E	27 mm												
Ex cable gland, polyamide, 7...13 mm 	PTB 13 ATEX 1015 X, IECEx PTB 13.0034X	II 2 G Ex e IIC Gb, II 2 D Ex tb IIIC Db IP68	<table border="1"> <tr><td>TL</td><td>36...45 mm</td></tr> <tr><td>L</td><td>10 mm</td></tr> <tr><td>D</td><td>20 mm</td></tr> <tr><td>SW</td><td>24 mm</td></tr> <tr><td>E</td><td>28 mm</td></tr> </table>	TL	36...45 mm	L	10 mm	D	20 mm	SW	24 mm	E	28 mm
TL	36...45 mm												
L	10 mm												
D	20 mm												
SW	24 mm												
E	28 mm												

DTS 1000082431 EN Version: M Status: RL (released | freigegeben | valide) printed: 26.02.2026

7.2. Special tool to turn the terminal box

Note:

This special tool is not included in the scope of delivery of the valve, see “8.5. Ordering chart accessories” on page 18.

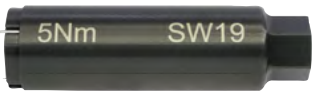
Description	Components of the set
Set SC02-AC10 	<ul style="list-style-type: none"> • Special tool • Service manual

8. Ordering information

8.1. Bürkert eShop



Bürkert eShop – Easy ordering and quick delivery

You want to find your desired Bürkert product or spare part quickly and order directly? Our online shop is available for you 24/7. Sign up and enjoy all the benefits.

Order online now

8.2. Bürkert product filter



Bürkert product filter – Get quickly to the right product

You want to select products comfortably based on your technical requirements? Use the Bürkert product filter and find suitable articles for your application quickly and easily.

Try out our product filter

8.3. Bürkert Product Enquiry Form

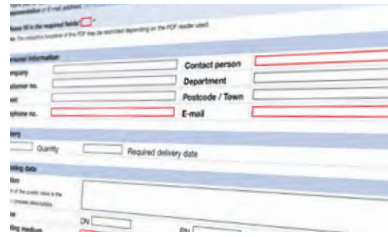

Bürkert Product Enquiry Form – Your enquiry quickly and compactly

Would you like to make a specific product enquiry based on your technical requirements? Use our Product Enquiry Form for this purpose. There you will find all the relevant information for your Bürkert contact. This will enable us to provide you with the best possible advice.

Fill out the form now

DTS 1000082431 EN Version: M Status: RL (released | freigegeben | valide) printed: 26.02.2026

8.4. Ordering chart

Basic variant with coil UL recognized (cURus)

Note:

Please note that the cable plug Type 2518 is included at the UL recognized variants. Further information can be found in chapter "Cable plug Type 2518, form A according to DIN EN 175301 - 803" on page 18 or separate data sheet Type 2518 ▶.

Circuit function	Port connection	Orifice [mm]	C _v flow coefficient water ¹⁾²⁾ [gal/min]	Pressure range ³⁾ (MAWP ⁴⁾) [psi]	Weight [lb]	Article no.			
						024/DC	024/50...60	120/60	240/60
						[V/Hz]	[V/Hz]	[V/Hz]	[V/Hz]
With threaded connection without manual override, without adjustable opening and closing times, with cable plug									
CF A	Brass body and seal material NBR, pressure range 3...232 psi								
2/2-way solenoid valve Servo-controlled Normally closed 	NPT 1/2	13	4.6	3...232	2.09	20068761 ☒	o. r.	20068764 ☒	o. r.
	NPT 3/4	20	7.5	3...232	3.09	20068762 ☒	o. r.	20068767 ☒	o. r.
	NPT 1	25	11.6	3...232	4.08	20068763 ☒	o. r.	20068768 ☒	o. r.
	NPT 1 1/4	32	23.1	3...232	5.73	o. r.	o. r.	o. r.	o. r.
	NPT 2	50	46.2	3...232	11.35	o. r.	o. r.	o. r.	o. r.
	NPT 2 1/2	65	46.2	3...232	13.01	o. r.	o. r.	o. r.	o. r.
	Stainless steel body and seal material FKM, pressure range 3...174 psi								
NPT 1/2	13	4.6	3...174	2.09	20068769 ☒	o. r.	20068772 ☒	o. r.	
NPT 3/4	20	7.5	3...174	3.09	20068770 ☒	o. r.	20068773 ☒	o. r.	
NPT 1	25	11.6	3...174	4.08	20068771 ☒	o. r.	20068774 ☒	o. r.	
NPT 1 1/4	32	23.1	3...174	5.73	o. r.	o. r.	o. r.	o. r.	
NPT 1 1/2	40	23.1	3...174	6.72	o. r.	o. r.	o. r.	o. r.	
NPT 2	50	46.2	3...174	11.35	o. r.	o. r.	o. r.	o. r.	
NPT 2 1/2	65	46.2	3...174	13.01	o. r.	o. r.	o. r.	o. r.	

o. r. = on request

- 1.) Flow coefficient at + 60 °F and pressure drop of 1 psi²⁾
- 2.) A pressure difference of 7.5 psi is required to open the full cross-section.
- 3.) Pressure data: overpressure to atmospheric pressure
- 4.) Maximum allowable working pressure

DTS 1000082431 EN Version: M Status: RL (released | freigegeben | valide) printed: 26.02.2026

UL Recognized & CSA approval – Brass body

Note:

Please note that the cable plug Type 2518 is included at the UL recognized variants. Further information can be found in chapter **“Cable plug Type 2518, form A according to DIN EN 175301 - 803” on page 18** or separate data sheet **Type 2518 ▶**

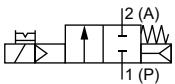
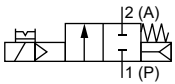
Circuit function	Port connection	Orifice [mm]	C _v flow coefficient water ¹⁾²⁾ [gal/min]	Pressure range ³⁾ (MAWP ⁴⁾) [psi]	Weight [lb]	Article no.			
						024/DC	024/50...60	120/60	240/60
						[V/Hz]	[V/Hz]	[V/Hz]	[V/Hz]
With threaded connection, manual override and cable plug									
CF A									
2/2-way solenoid valve Normally closed									
Seal material NBR, pressure range 3...145 psi									
									
NPT 1/2	13	4.6	3...145	2.09	456890	456891	456892	456893	
NPT 3/4	20	7.5	3...145	3.09	456894	456895	456896	456897	
NPT 1	25	11.6	3...145	4.08	456898	456899	456900	456901	
NPT 1 1/4	32	23.1	3...145	5.73	456902	456903	456904	456905	
NPT 1 1/2	40	23.1	3...145	6.72	456906	456907	456908	456909	
NPT 2	50	46.2	3...145	11.35	456910	456911	456912	456913	
NPT 2 1/2	65	46.2	3...145	13.01	92704814	o. r.	o. r.	o. r.	
Seal material FKM, pressure range 3...145 psi									
NPT 1/2	13	4.6	3...145	2.09	o. r.	o. r.	98106351	o. r.	
NPT 3/4	20	7.5	3...145	3.09	o. r.	o. r.	o. r.	o. r.	
NPT 1	25	11.6	3...145	4.08	o. r.	o. r.	98106352	287149	
NPT 1 1/4	32	23.1	3...145	5.73	o. r.	o. r.	o. r.	o. r.	
NPT 1 1/2	40	23.1	3...145	6.72	466250	462248	o. r.	o. r.	
NPT 2	50	46.2	3...145	11.35	o. r.	462249	o. r.	o. r.	
NPT 2 1/2	65	46.2	3...145	13.01	o. r.	o. r.	o. r.	o. r.	
Seal material EPDM, pressure range 3...145 psi									
NPT 1/2	13	4.6	3...145	2.09	o. r.	o. r.	o. r.	o. r.	
NPT 3/4	20	7.5	3...145	3.09	o. r.	o. r.	o. r.	468653	
NPT 1	25	11.6	3...145	4.08	468029	466706	o. r.	o. r.	
NPT 1 1/4	32	23.1	3...145	5.73	o. r.	o. r.	o. r.	o. r.	
NPT 1 1/2	40	23.1	3...145	6.72	o. r.	o. r.	o. r.	o. r.	
NPT 2	50	46.2	3...145	11.35	o. r.	o. r.	o. r.	o. r.	
NPT 2 1/2	65	46.2	3...145	13.01	o. r.	o. r.	o. r.	o. r.	
CF A									
2/2-way solenoid valve Normally closed									
Seal material NBR, pressure range 3...232 psi									
									
NPT 1/2	13.0	4.6	3...232	2.09	o. r.	464500	o. r.	o. r.	
NPT 3/4	20.0	7.5	3...232	3.09	o. r.	o. r.	o. r.	o. r.	
NPT 1	25.0	11.6	3...232	4.08	o. r.	o. r.	o. r.	o. r.	
NPT 1 1/4	32.0	23.1	3...232	5.73	o. r.	o. r.	o. r.	o. r.	
NPT 1 1/2	40.0	23.1	3...232	6.72	o. r.	o. r.	o. r.	o. r.	
NPT 2	50.0	46.2	3...232	11.35	o. r.	o. r.	o. r.	o. r.	
CF B									
2/2-way solenoid valve Normally open									
Seal material NBR, pressure range 3...232 psi									
									
NPT 1/2	13.0	4.6	3...232	2.09	o. r.	o. r.	o. r.	o. r.	
NPT 3/4	20.0	7.5	3...232	3.09	o. r.	o. r.	o. r.	o. r.	
NPT 1	25.0	11.6	3...232	4.08	o. r.	o. r.	o. r.	o. r.	
NPT 1 1/4	32.0	23.1	3...232	5.73	o. r.	o. r.	o. r.	o. r.	
NPT 1 1/2	40.0	23.1	3...232	6.72	o. r.	o. r.	o. r.	o. r.	
NPT 2	50.0	46.2	3...232	11.35	o. r.	o. r.	o. r.	o. r.	

o. r. = on request

1.) Flow coefficient at + 60 °F and pressure drop of 1 psi²⁾

2.) A pressure difference of 7.5 psi is required to open the full cross-section.

3.) Pressure data: overpressure to atmospheric pressure

4.) Maximum allowable working pressure

DTS 1000082431 EN Version: M Status: RL (released | freigegeben | valide) printed: 26.02.2026

UL Recognized & CSA approval – Stainless steel body

Note:

Please note that the cable plug Type 2518 is included at the UL recognized variants. Further information can be found in chapter **“Cable plug Type 2518, form A according to DIN EN 175301 - 803” on page 18** or separate data sheet **Type 2518** ▶

Circuit function	Port connection	Orifice [mm]	C _v flow coefficient water ¹⁾²⁾ [gal/min]	Pressure range ³⁾ (MAWP ⁴⁾ [psi]	Weight [lb]	Article no.			
						024/DC	024/50...60	120/60	240/60
						[V/Hz]	[V/Hz]	[V/Hz]	[V/Hz]
With threaded connection, manual override and cable plug									
CF A									
2/2-way solenoid valve Normally closed									
Seal material NBR, pressure range 3...145 psi									
	NPT 1/2	13	4.6	3...145	2.09	o. r.	o. r.	o. r.	o. r.
	NPT 3/4	20	7.5	3...145	3.09	463442 𐀀	o. r.	o. r.	o. r.
	NPT 1	25	11.6	3...145	4.08	463441 𐀀	o. r.	462248 𐀀	o. r.
	NPT 1 1/4	32	23.1	3...145	5.73	o. r.	o. r.	o. r.	o. r.
	NPT 1 1/2	40	23.1	3...145	6.72	o. r.	o. r.	o. r.	o. r.
	NPT 2	50	46.2	3...145	11.35	o. r.	o. r.	o. r.	o. r.
Seal material FKM, pressure range 3...145 psi									
	NPT 1/2	13	4.6	3...145	2.09	o. r.	o. r.	463867 𐀀	o. r.
	NPT 3/4	20	7.5	3...145	3.09	456918 𐀀	456919 𐀀	456920 𐀀	456921 𐀀
	NPT 1	25	11.6	3...145	4.08	456922 𐀀	456923 𐀀	456924 𐀀	456925 𐀀
	NPT 1 1/4	32	23.1	3...145	5.73	456926 𐀀	456927 𐀀	456928 𐀀	456929 𐀀
	NPT 1 1/2	40	23.1	3...145	6.72	456930 𐀀	456931 𐀀	456932 𐀀	456933 𐀀
	NPT 2	50	46.2	3...145	11.35	456934 𐀀	456935 𐀀	456936 𐀀	456937 𐀀
Seal material EPDM, pressure range 3...145 psi									
	NPT 1/2	13	4.6	3...145	2.09	463868 𐀀	o. r.	463869 𐀀	o. r.
	NPT 3/4	20	7.5	3...145	3.09	464457 𐀀	465040 𐀀	o. r.	o. r.
	NPT 1	25	11.6	3...145	4.08	20002392 𐀀	o. r.	o. r.	o. r.
	NPT 1 1/4	32	23.1	3...145	5.73	o. r.	o. r.	o. r.	o. r.
	NPT 1 1/2	40	23.1	3...145	6.72	20002392 𐀀	o. r.	465284 𐀀	o. r.
	NPT 2	50	46.2	3...145	11.35	o. r.	o. r.	20014104 𐀀	o. r.

o. r. = on request

- 1.) Flow coefficient at + 60 °F and pressure drop of 1 psi²⁾
- 2.) A pressure difference of 7.5 psi is required to open the full cross-section.
- 3.) Pressure data: overpressure to atmospheric pressure
- 4.) Maximum allowable working pressure

UL Listed – Brass body

Note:

Please note that the cable plug Type 2509 is included at the UL Listed variants. Further information can be found in chapter “Cable plug Type 2509, form A according to DIN EN 175301 - 803” on page 18 or separate data sheet Type 2509 ▶.

Circuit function	Port connection	Orifice [mm]	C _v flow coefficient water ¹⁾²⁾ [gal/min]	Pressure range ³⁾ (MAWP ⁴⁾) [psi]	Weight [lb]	Article no.			
						024/DC	024/50...60	120/60	240/60
						[V/Hz]	[V/Hz]	[V/Hz]	[V/Hz]
With threaded connection, manual override and cable plug									
CF A									
2/2-way solenoid valve Normally closed									
Seal material NBR, pressure range 3...145 psi									
	NPT 1/2	13.0	4.6	3...145	2.09	329291 ☞	329331 ☞	329285 ☞	329325 ☞
	NPT 3/4	20.0	7.5	3...145	3.09	329299 ☞	o. r.	329293 ☞	329326 ☞
	NPT 1	25.0	11.6	3...145	4.08	329288 ☞	329327 ☞	329286 ☞	o. r.
	NPT 1 1/4	32.0	23.1	3...145	5.73	341697 ☞	o. r.	329333 ☞	329334 ☞
	NPT 1 1/2	40.0	23.1	3...145	6.72	329303 ☞	o. r.	329311 ☞	o. r.
	NPT 2	50.0	46.2	3...145	11.35	329298 ☞	o. r.	329284 ☞	o. r.
	NPT 2 1/2	65.0	46.2	3...145	13.01	o. r.	o. r.	o. r.	o. r.
	Seal material FKM, pressure range 3...145 psi								
	NPT 1/2	13.0	4.6	3...145	2.09	329313 ☞	o. r.	o. r.	o. r.
	NPT 3/4	20.0	7.5	3...145	3.09	o. r.	o. r.	o. r.	o. r.
	NPT 1	25.0	11.6	3...145	4.08	o. r.	o. r.	o. r.	o. r.
	NPT 1 1/4	32.0	23.1	3...145	5.73	o. r.	o. r.	329336 ☞	o. r.
	NPT 1 1/2	40.0	23.1	3...145	6.72	o. r.	o. r.	o. r.	o. r.
	NPT 2	50.0	46.2	3...145	11.35	o. r.	o. r.	o. r.	o. r.
	NPT 2 1/2	65.0	46.2	3...145	13.01	o. r.	o. r.	o. r.	o. r.
	Seal material EPDM, pressure range 3...145 psi								
	NPT 1/2	13.0	4.6	3...145	2.09	329330 ☞	o. r.	o. r.	o. r.
	NPT 3/4	20.0	7.5	3...145	3.09	o. r.	o. r.	o. r.	o. r.
	NPT 1	25.0	11.6	3...145	4.08	o. r.	o. r.	o. r.	o. r.
	NPT 1 1/4	32.0	23.1	3...145	5.73	o. r.	o. r.	o. r.	o. r.
	NPT 1 1/2	40.0	23.1	3...145	6.72	o. r.	o. r.	o. r.	o. r.
	NPT 2	50.0	46.2	3...145	11.35	o. r.	o. r.	o. r.	o. r.
	NPT 2 1/2	65.0	46.2	3...145	13.01	o. r.	o. r.	o. r.	o. r.
	Seal material NBR, pressure range 3...232 psi								
	NPT 1/2	13.0	4.6	3...232	2.09	20068156 ☞	o. r.	20068157 ☞	o. r.
	NPT 3/4	20.0	7.5	3...232	3.09	20068158 ☞	o. r.	20068159 ☞	o. r.
	NPT 1	25.0	11.6	3...232	4.08	20068162 ☞	o. r.	20068163 ☞	o. r.
	NPT 1 1/4	32.0	23.1	3...232	5.73	20068166 ☞	o. r.	20068167 ☞	o. r.
	NPT 1 1/2	40.0	23.1	3...232	6.72	20068170 ☞	o. r.	20068172 ☞	o. r.
	NPT 2	50.0	46.2	3...232	11.35	20068177 ☞	o. r.	20068178 ☞	o. r.
	Seal material FKM, pressure range 3...232 psi								
	NPT 1/2	13.0	4.6	3...232	2.09	o. r.	o. r.	o. r.	o. r.
	NPT 3/4	20.0	7.5	3...232	3.09	o. r.	o. r.	o. r.	o. r.
	NPT 1	25.0	11.6	3...232	4.08	o. r.	o. r.	o. r.	o. r.
	NPT 1 1/4	32.0	23.1	3...232	5.73	o. r.	o. r.	o. r.	o. r.
	NPT 1 1/2	40.0	23.1	3...232	6.72	o. r.	o. r.	o. r.	o. r.
	NPT 2	50.0	46.2	3...232	11.35	o. r.	o. r.	o. r.	o. r.

o. r. = on request

- 1.) Flow coefficient at + 60 °F and pressure drop of 1 psi²⁾
- 2.) A pressure difference of 7.5 psi is required to open the full cross-section.
- 3.) Pressure data: overpressure to atmospheric pressure
- 4.) Maximum allowable working pressure

DTS 1000082431 EN Version: M Status: RL (released | freigegeben | valide) printed: 26.02.2026

UL Listed – Stainless steel body

Note:

Please note that the cable plug Type 2509 is included at the UL Listed variants. Further information can be found in chapter “Cable plug Type 2509, form A according to DIN EN 175301 - 803” on page 18 or separate data sheet **Type 2509** ▶.

Circuit function	Port connection	Orifice [mm]	C _v flow coefficient water ¹⁾²⁾ [gal/min]	Pressure range ³⁾ (MAWP ⁴⁾ [psi]	Weight [lb]	Article no.			
						024/DC	024/50...60	120/60	240/60
						[V/Hz]	[V/Hz]	[V/Hz]	[V/Hz]
With threaded connection, manual override and cable plug									
CF A 2/2-way solenoid valve Servo-controlled, with manual override Normally closed									
Seal material NBR, pressure range 3...145 psi									
	NPT 1/2	13.0	4.6	3...145	2.09	329297	o. r.	o. r.	o. r.
	NPT 3/4	20.0	7.5	3...145	3.09	o. r.	o. r.	o. r.	o. r.
	NPT 1	25.0	11.6	3...145	4.08	o. r.	o. r.	o. r.	o. r.
	NPT 1 1/4	32.0	23.1	3...145	5.73	o. r.	o. r.	o. r.	o. r.
	NPT 1 1/2	40.0	23.1	3...145	6.72	o. r.	o. r.	o. r.	o. r.
	NPT 2	50.0	46.2	3...145	11.35	o. r.	o. r.	o. r.	o. r.
	Seal material FKM, pressure range 3...145 psi								
	NPT 1/2	13.0	4.6	3...145	2.09	o. r.	o. r.	o. r.	o. r.
	NPT 3/4	20.0	7.5	3...145	3.09	329304	o. r.	329282	o. r.
	NPT 1	25.0	11.6	3...145	4.08	329310	o. r.	329290	o. r.
	NPT 1 1/4	32.0	23.1	3...145	5.73	329337	o. r.	329328	o. r.
	NPT 1 1/2	40.0	23.1	3...145	6.72	329305	o. r.	329292	o. r.
	NPT 2	50.0	46.2	3...145	11.35	329323	o. r.	329324	o. r.
	Seal material EPDM, pressure range 3...145 psi								
	NPT 1/2	13.0	4.6	3...145	2.09	o. r.	o. r.	o. r.	o. r.
	NPT 3/4	20.0	7.5	3...145	3.09	o. r.	o. r.	o. r.	o. r.
	NPT 1	25.0	11.6	3...145	4.08	o. r.	o. r.	o. r.	o. r.
	NPT 1 1/4	32.0	23.1	3...145	5.73	o. r.	o. r.	329320	o. r.
	NPT 1 1/2	40.0	23.1	3...145	6.72	o. r.	o. r.	o. r.	o. r.
	NPT 2	50.0	46.2	3...145	11.35	o. r.	o. r.	o. r.	o. r.

- o. r. = on request
- 1.) Flow coefficient at + 60 °F and pressure drop of 1 psi²⁾
 - 2.) A pressure difference of 7.5 psi is required to open the full cross-section.
 - 3.) Pressure data: overpressure to atmospheric pressure
 - 4.) Maximum allowable working pressure

Further variants on request	
<p>Additionally With optical position indicator or electrical position feedback sensor as potential-free contact or Namur signal</p>	<p>Pressure Pressure range up to 232 psi</p>
<p>Approval UL, UR, CSA, Hazardous Locations Expl. proof, Ex, KOSHA, NEPSI, CGA/AGA, FM Ex Div. 1 or 2, drinking water approval acc. to UBA assessment principles (PF36/PF39), impulse variant</p>	<p>Voltage Further voltages</p>

DTS 1000082431 EN Version: M Status: RL (released | freigegeben | valide) printed: 26.02.2026

ATEX/IECEX variant – coil UL Listed (cULus) for hazardous locations, Class I, Division 2

Note:

- Max. switching frequency 20/min at max. medium temperature 158 °F and max. ambient temperature 104 °F
- Max. switching frequency 5/min at max. medium temperature 194 °F and max. ambient temperature 131 °F

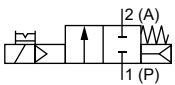
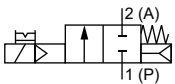
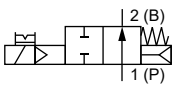
Circuit function	Port connection	Orifice [mm]	C, flow coefficient water ^{1,2,)} [gal/min]	Pressure range ^{3,)} (MAWP ^{4,)} [psi]	Weight [lb]	Article no.		
						024 / AC/DC [V/Hz]	120 / AC/DC [V/Hz]	
With manual override and terminal box								
CF A 2/2-way solenoid valve Servo-controlled, with manual override Normally closed 	Brass body with threaded connection, seal material FKM							
	NPT 1/2	13.0	4.6	7..145	2.09	o. r.	o. r.	
	NPT 3/4	20.0	7.5	7..145	3.09	o. r.	o. r.	
	NPT 1	25.0	11.6	7..145	4.08	o. r.	387818 𐀀	
	NPT 1 1/4	32.0	23.1	7..145	5.73	o. r.	o. r.	
	NPT 1 1/2	40.0	23.1	7..145	6.72	o. r.	o. r.	
	NPT 2	50.0	46.2	7..145	11.35	o. r.	o. r.	
	Stainless steel body with threaded connection, seal material FKM							
	NPT 1/2	13.0	4.6	7..145	2.09	o. r.	o. r.	
	NPT 3/4	20.0	7.5	7..145	3.09	20027492 𐀀	o. r.	
	NPT 1	25.0	11.6	7..145	4.08	o. r.	o. r.	
	NPT 1 1/4	32.0	23.1	7..145	5.73	o. r.	o. r.	
	NPT 1 1/2	40.0	23.1	7..145	6.72	o. r.	o. r.	
	NPT 2	50.0	46.2	7..145	11.35	20067637 𐀀	o. r.	
With manual override and cable outlet, cable 3 m								
CF A 2/2-way solenoid valve Servo-controlled, with manual override Normally closed 	Brass body with threaded connection, seal material NBR							
	NPT 1/2	13.0	4.6	7..145	2.09	o. r.	376521 𐀀	
	NPT 3/4	20.0	7.5	7..145	3.09	387683 𐀀	377257 𐀀	
	NPT 1	25.0	11.6	7..145	4.08	o. r.	o. r.	
	NPT 1 1/4	32.0	23.1	7..145	5.73	o. r.	o. r.	
	NPT 1 1/2	40.0	23.1	7..145	6.72	o. r.	20002918 𐀀	
	NPT 2	50.0	46.2	7..145	11.35	o. r.	o. r.	
	NPT 2 1/2	65.0	46.2	7..145	13.01	20002394 𐀀	o. r.	
	CF B 2/2-way solenoid valve Servo-controlled, with manual override Normally open 							

o. r. = on request

- 1.) Flow coefficient at + 60 °F and pressure drop of 1 psi²⁾
- 2.) A pressure difference of 7.5 psi is required to open the full cross-section.
- 3.) Pressure data: overpressure to atmospheric pressure
- 4.) Maximum allowable working pressure

Further variants on request

 Material Seal material: NBR, FKM, EPDM	 Pressure Pressure range up to 232 psi
 Voltage 110/UC	

DTS 1000082431 EN Version: M Status: RL (released | freigegeben | valide) printed: 26.02.2026

8.5. Ordering chart accessories

Cable plug Type 2518, form A according to DIN EN 175301 - 803

Note:

- Dimensions in mm
- For further variants see data sheet **Type 2518** ▶

Cable plug	Dimensions	Variant	Voltage	Article no.
		Without wiring (AC/DC)	0...250 V AC/DC	314802 𐀀
		With LED (AC/DC)	12...24 V AC/DC	314812 𐀀
		With LED and varistor (AC/DC)	12...24 V AC/DC	314820 𐀀
		With rectifier, LED and varistor	12...24 V AC/DC	314816 𐀀
		Without wiring (AC/DC) with silicone seal for higher ambient temperature, e.g. steam variant (NA07)	0...250 V AC/DC	361687 𐀀

Cable plug Type 2509, form A according to DIN EN 175301 - 803

Note:

- Dimensions in mm
- Without wiring (standard)
- Refer to data sheet **Type 2509** ▶ for more information about the cable plug.

Cable plug	Dimensions	Variant	Voltage	Article no.
		Without wiring	0...250 V AC/DC	137943 𐀀

Cable glands for ATEX/IECEx terminal box

Note:

- A polyamide cable gland is included in the scope of delivery. A nickel-plated brass variant can be ordered for a surcharge.
- Refer to **"7.1. Cable glands for ATEX/IECEx terminal box"** on page 10 for more information about Ex cable glands.
- Refer to **"7.2. Special tool to turn the terminal box"** on page 11 for more information about special tool.

Description	Article no.
Ex cable gland, nickel-plated brass, 6...13 mm ¹⁾	773278 𐀀
Ex cable gland, polyamide, 7...13 mm ¹⁾	773277 𐀀
Set SC02-AC10: special tool ²⁾ incl. service manual	293488 𐀀

1.) Cable diameter

2.) Not included in the scope of delivery of the valve