









### Electrical Rotary Actuator - On/off and control

- Direct mounting on quarter-turn valves (ball and butterfly valves)
- Manual override in standard
- Adjustable limit switches
- Multi-voltage

Product variants described in the data sheet may differ from the product presentation and description.

#### Can be combined with

	<b>Type 2651</b> 2/2-way or 3/2-way ball valve, 2-piece	▶
	<b>Type 2654</b> 2/2-way ball valve, 3-piece	▶
	<b>Type 2657</b> Ball valve, manually operated	▶
	<b>Type 2671</b> Butterfly valve	▶
	<b>Type 2674</b> Plastic butterfly valve	▶
	<b>Type TKU001</b> 2/2 way compact flange ball valve	▶
	<b>Type 8804</b> Ball valve / butterfly valve with electrical rotary actuator	▶

#### Type description

The electrical rotary actuator Type 3003 is a compact and powerful actuator system with a long service life. Materials and components have been chosen for a maintenance-free operation even in aggressive environments and ensure low thermal loading on the actuator. The modular design offers many additional features to be added to the basic device such as extra limit switches, potentiometers and emergency power. With the control actuator version the input signals as well as the output signals (e.g., 4...20 mA, 0...20 mA, 0...10 V) can be programmed. Heating resistors and torque limiters are standard features. The housing is made of flame-resistant material classified according to UL 94 V0.

## Table of contents

<b>1. General technical data</b>	<b>3</b>
<hr/>	
<b>2. Approvals and conformities</b>	<b>4</b>
2.1. General notes .....	4
2.2. Conformity .....	4
2.3. Standards .....	4
2.4. North America (USA/Canada) .....	4
<hr/>	
<b>3. Materials</b>	<b>4</b>
3.1. Bürkert resistApp .....	4
<hr/>	
<b>4. Dimensions</b>	<b>5</b>
4.1. Small motor with 10, 20, 35 Nm, double square 14 mm .....	5
4.2. Large motor with 35, 80, 100 Nm, double square 22 mm .....	6
<hr/>	
<b>5. Product connections</b>	<b>7</b>
5.1. Electrical connections .....	7
Standard actuators for use in On/Off and 3-point mode .....	7
Control variant 4...20 mA, 0...20 mA or 0...10 V programmable analogue signal input and output .....	8
Actuators with emergency reset (BBPR - BB40) .....	9
3-position actuators (0°, 90°, 180°) .....	10
<hr/>	
<b>6. Product design and assembly</b>	<b>11</b>
6.1. Product assembly .....	11
<hr/>	
<b>7. Ordering information</b>	<b>11</b>
7.1. Bürkert eShop .....	11
7.2. Bürkert product filter .....	12
7.3. Ordering chart .....	12
On/Off variant .....	12
On/Off variant, long rotation time .....	12
Control variant with 4...20 mA, 0...20 mA or 0...10 V programmable analogue signal input and output .....	13
On/Off variant with emergency reset via integrated battery: fail-to-close/open adjustable <sup>1)</sup> .....	13
On/Off variant with emergency reset via integrated battery: fail-to-close/open adjustable <sup>1)</sup> , long rotation time .....	13
3-position variant (0°, 90°, 180°) .....	14
3-position variant (0°, 90°, 180°), long rotation time .....	14
7.4. Ordering chart accessories .....	14
Reducing sleeves .....	14
Spare battery for actuators with electronic emergency reset .....	15
Other accessories .....	15

## 1. General technical data

Product properties	
Dimensions	Further information can be found in chapter "4. Dimensions" on page 5.
<b>Material</b>	
Cover	Nylon
Body	PA 6.6
Axis	Stainless steel
Screws	Stainless steel
Gear	Stainless steel and PC
<b>Weight</b>	
Small actuator variant (10, 20, 35 Nm)	1 kg Further information can be found in chapter "4. Dimensions" on page 5.
Large actuator variant (35, 60, 100 Nm)	2.1 kg Further information can be found in chapter "4. Dimensions" on page 5.
Manual override	Uncoupling by gearbox-coupled rotary knob Further information can be found in the <b>operating instructions Type 3003</b> ►.
Position indicator	Standard
Performance data	
Torque	10, 20, 35, 60, 100 Nm Further information can be found in chapter "7.3. Ordering chart" on page 12.
Rotation angle	90° (± 5°) (special angles on request)
Rotation time (90°)	7...119 s Further information can be found in chapter "7.3. Ordering chart" on page 12.
Options	<ul style="list-style-type: none"> <li>• Various actuating times</li> <li>• 3-position actuator (for 180° actuators: end positions preset to 0°, 90°, 180°)</li> <li>• Position feedback of the on/off variant via:               <ul style="list-style-type: none"> <li>– Potentiometer (1000, 5000, 10 000 Ω)</li> <li>– Analogue signal 4...20 mA</li> </ul> </li> <li>• Emergency power variant</li> <li>• Auxiliary limit switches</li> </ul>
Electrical data	
Operating voltage	15...30 V AC, 50...60 Hz, 12...48 V DC 100...240 V AC, 50...60 Hz, 100...350 V DC
Limit switches	4 adjustable (2 for the motor and 2 additional for feedback), max. 250 V AC / 5 A
Power consumption	15...45 W Further information can be found in chapter "7.3. Ordering chart" on page 12.
Voltage tolerance	± 10 %
<b>Analogue signals in control variant</b>	
Input	0...10 V / 4...20 mA / 0...20 mA
Output	0...10 V / 4...20 mA / 0...20 mA
Motor protection	Electronic torque limiter
Duty cycle	According to IEC34, S4 = 50 %
Heating resistor	Standard
Product connections and communication	
Electrical connection	Cable plug according to EN 175301 - 803 (supply voltage) included, cable glands according to ISO M20
Armature-side interface	Inside double square Further information can be found in chapter "7.3. Ordering chart" on page 12.
ISO mounting plate	According to ISO 5211 Further information can be found in chapter "7.3. Ordering chart" on page 12.
Approvals and conformities	
Degree of protection	IP66 if mounted with cable plug
North America (USA/Canada)	Further information can be found in chapter "2.4. North America (USA/Canada)" on page 4.
Environment and installation	
Installation position	Do not install the actuator upside down, maximum installation angle: 90°.
Operating altitude	Up to max. 2000 m altitude

**Ambient temperature**

For actuator Type 3003 Standard -10 °C...+ 55 °C  
 For actuator Type 3003 with electronic emergency reset -10 °C...+ 40 °C

**2. Approvals and conformities**

**2.1. General notes**

- The approvals and conformities listed below must be stated when making enquiries. This is the only way to ensure that the product complies with all required specifications.
- Not all available variants can be supplied with the below mentioned approvals or conformities.

**2.2. Conformity**

In accordance with the Declaration of Conformity, the product is compliant with the EU Directives.

**2.3. Standards**

The applied standards which are used to demonstrate compliance with the EU Directives are listed in the EU-Type Examination Certificate and/or the EU Declaration of Conformity.

**2.4. North America (USA/Canada)**

Approval	Description
	<p><b>Optional: CSA for Canada and the USA</b>                      The products are CSA-approved for Canada and the USA according to:</p> <ul style="list-style-type: none"> <li>• CAN/CSA-C22.2 No. 139 - Electrically operated valves</li> <li>• UL 429 - Electrically operated valves</li> </ul>

**3. Materials**

**3.1. Bürkert resistApp**

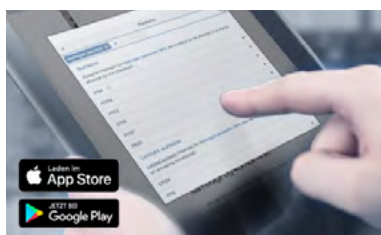

**Bürkert resistApp – Chemical resistance chart**

You want to ensure the reliability and durability of the materials in your individual application case? Verify your combination of media and materials on our website or in our resistApp.

[Start chemical resistance check](#)

DTS 1000020592 EN Version: AU Status: RL (released | freigegeben | valide) printed: 22.04.2026

## 4. Dimensions

### 4.1. Small motor with 10, 20, 35 Nm, double square 14 mm

**Note:**

Dimensions in mm

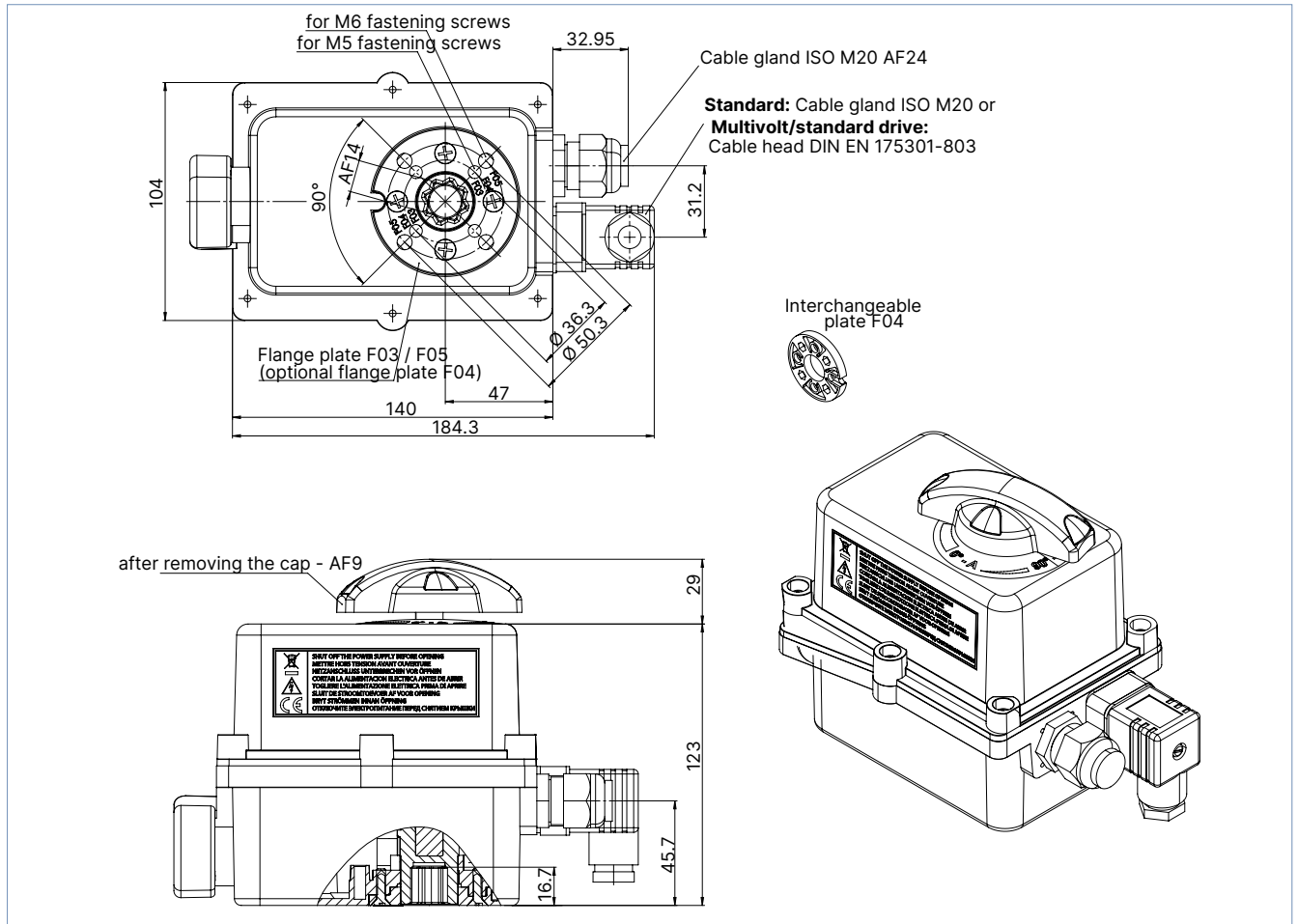

Square/double square	Depth
14	16
17	19
22	24

Armature-side interface according to ISO 5211	Diameter	M thread	Depth	Number of screws
F03	36	M5	14.2	4
F04	42	M5	14.2	4
F05	50	M6	14.2/16.4	4
F07	70	M8	16.4	4

DTS 1000020592 EN Version: AU Status: RL (released | freigegeben | valide) printed: 22.04.2026

### 4.2. Large motor with 35, 80, 100 Nm, double square 22 mm

**Note:**

Dimensions in mm

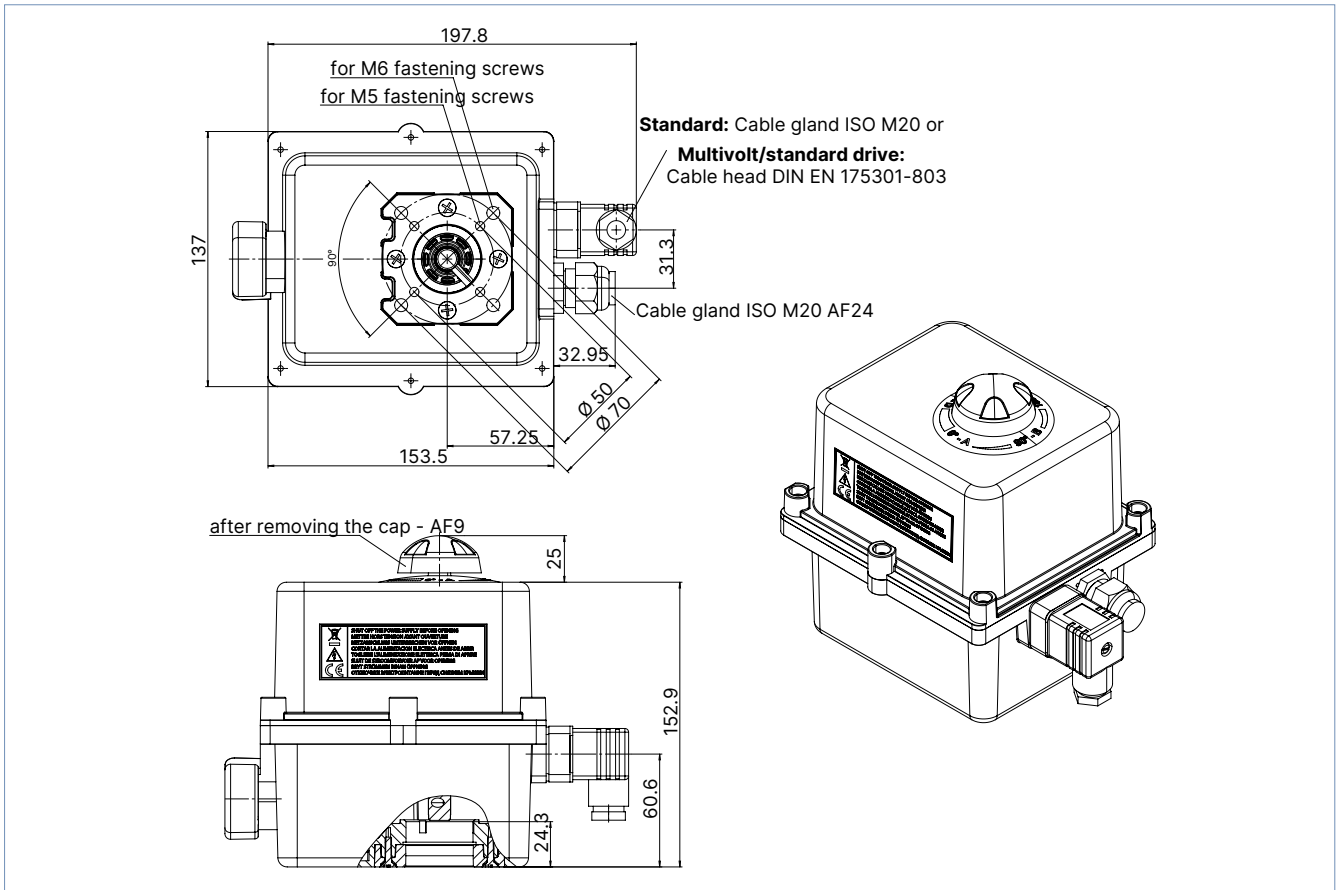

Square/double square	Depth
14	16
17	19
22	24

Armature-side interface according to ISO 5211	Diameter	M thread	Depth	Number of screws
F03	36	M5	14.2	4
F04	42	M5	14.2	4
F05	50	M6	14.2/16.4	4
F07	70	M8	16.4	4

## 5. Product connections

### 5.1. Electrical connections

#### Standard actuators for use in On/Off and 3-point mode

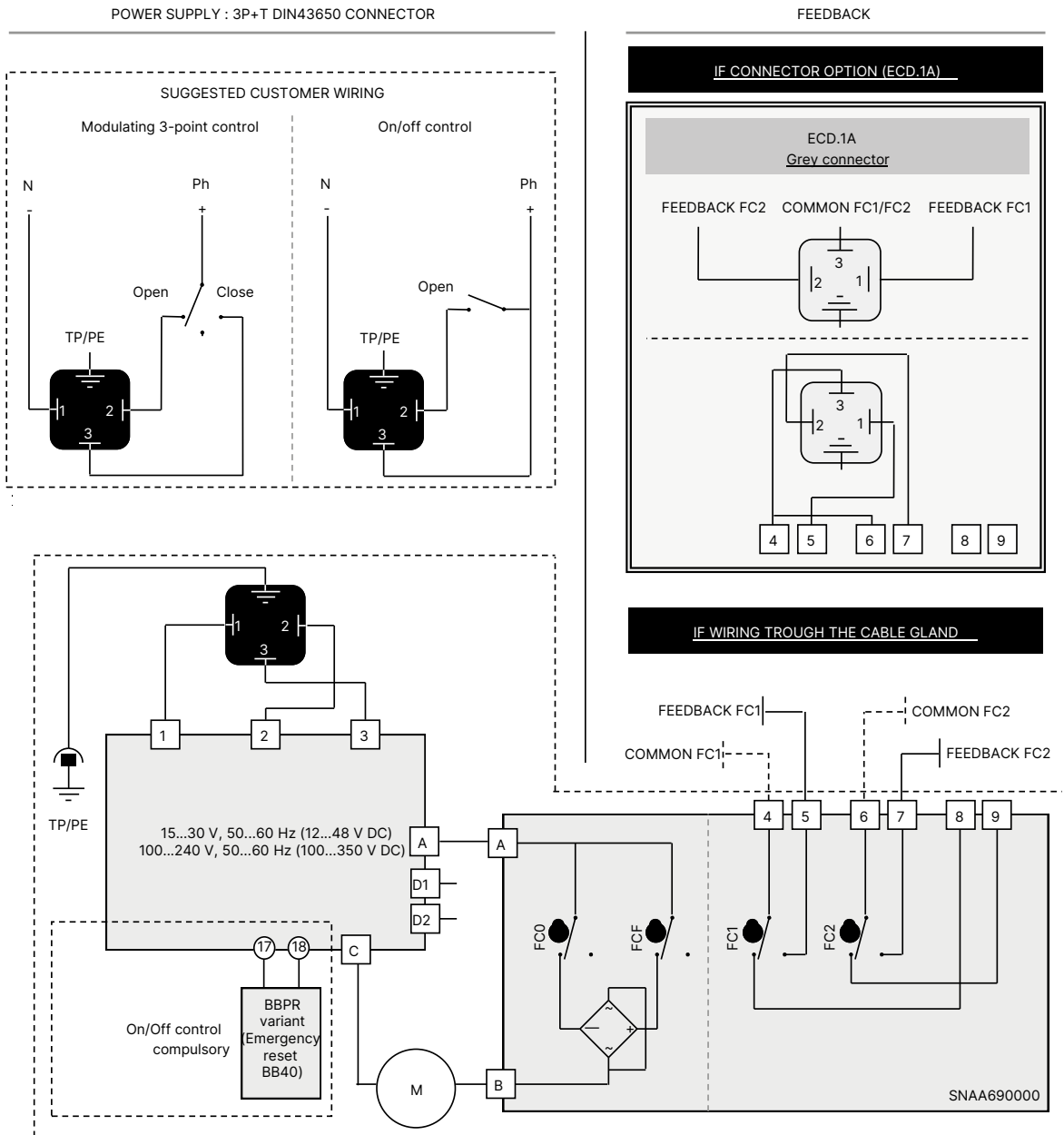

DTS 1000020592 EN Version: AU Status: RL (released | freigegeben | valide) printed: 22.04.2026

Symbol	Designation
FCO	Limit switch OPEN
FCF	Limit switch CLOSED
FC1	Auxiliary limit switch 1
FC2	Auxiliary limit switch 2

**Control variant 4...20 mA, 0...20 mA or 0...10 V programmable analogue signal input and output**

**Note:**

- The resolution of the closed-loop control mode is 1°.
- The input resistance for control 0...10 V is 10 kΩ.
- The input resistance for control 0...20 mA/4...20 mA is 100 Ω.

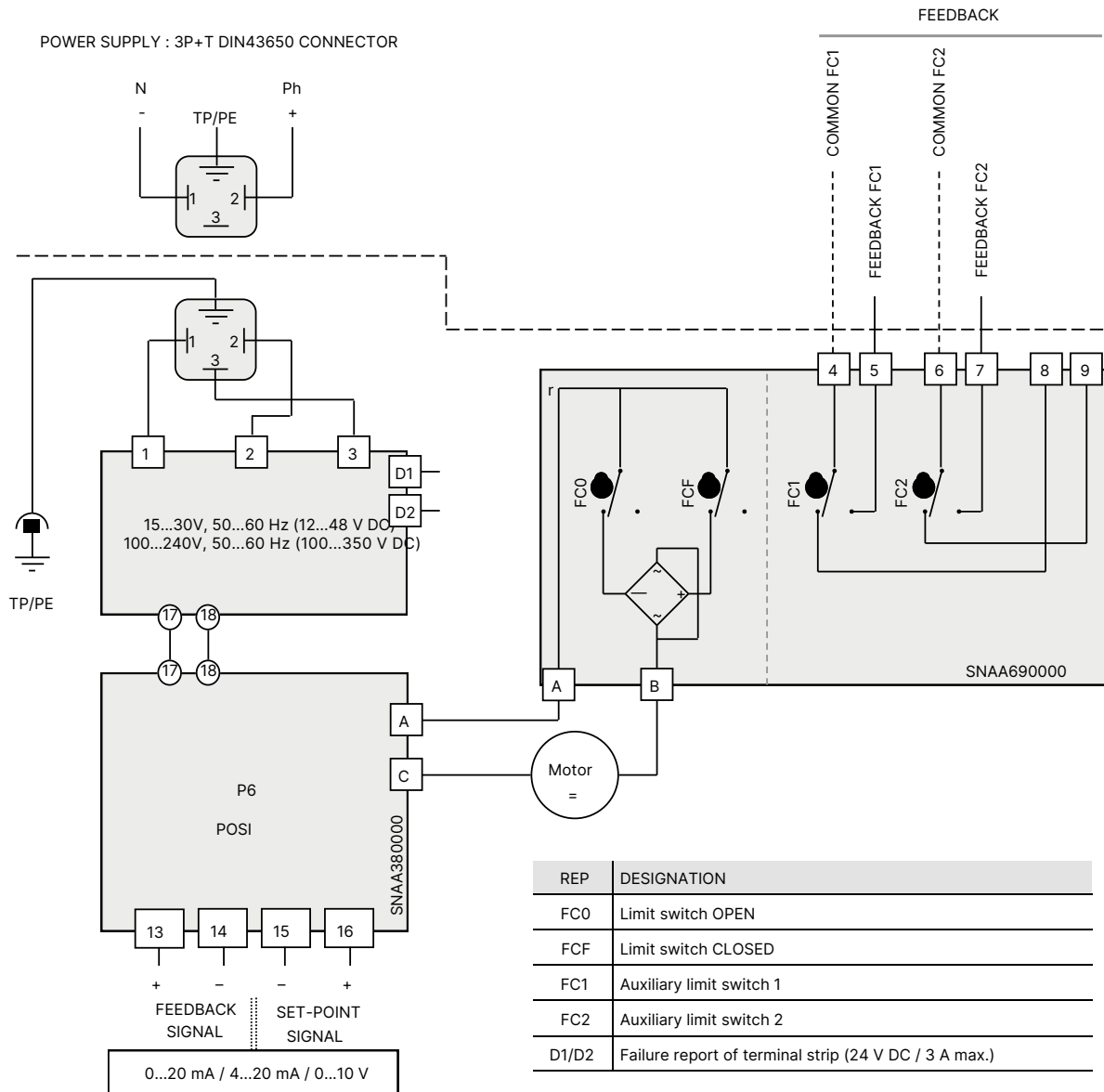

DTS 1000020592 EN Version: AU Status: RL (released | freigegeben | valide) printed: 22.04.2026

Actuators with emergency reset (BBPR - BB40)

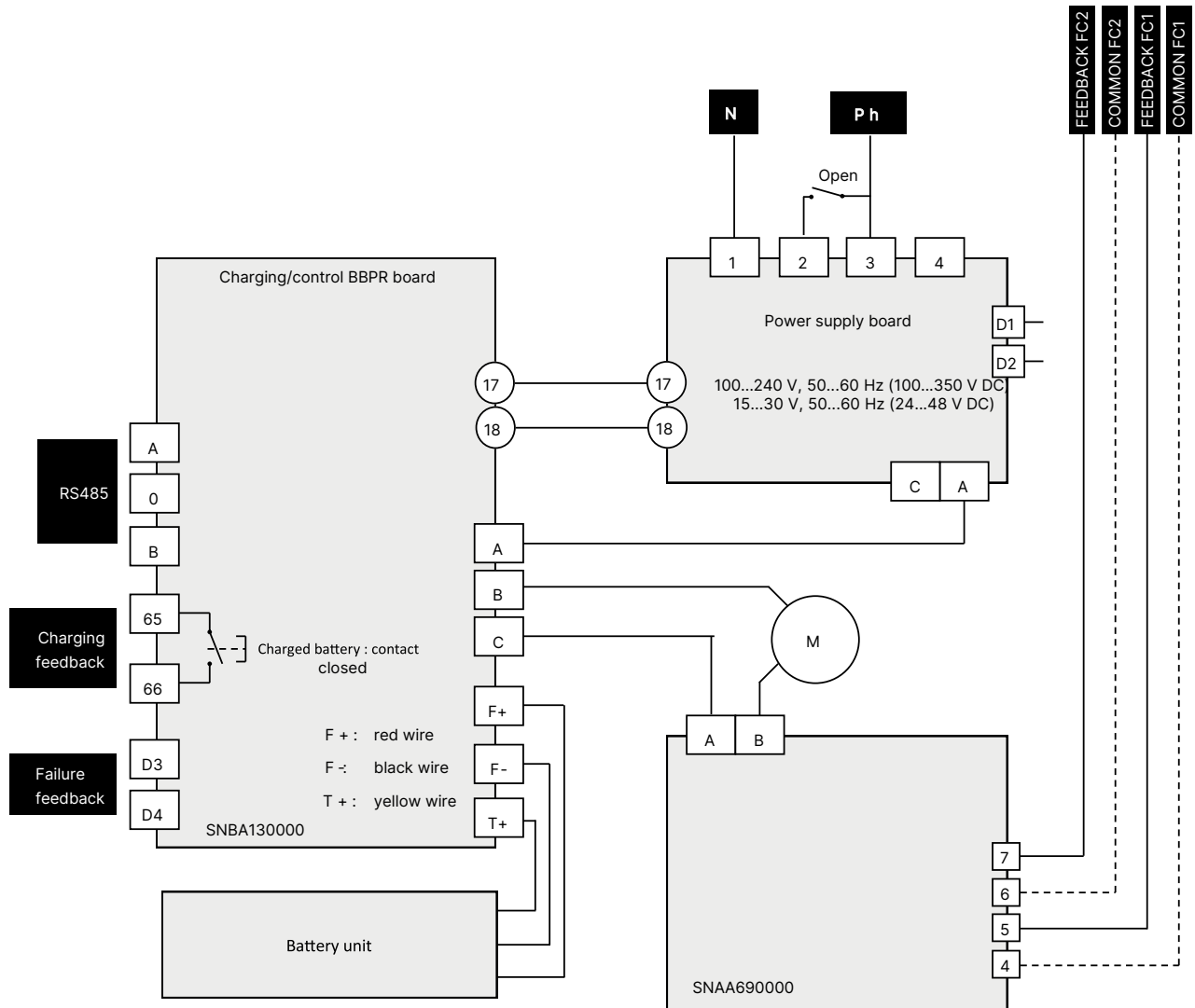

DTS 1000020592 EN Version: AU Status: RL (released | freigegeben | valide) printed: 22.04.2026

**3-position actuators (0°, 90°, 180°)**

**Note:**

The 3-position design allows the user to move the actuator to 3 predefined positions. These 3 positions can be in a swivelling range between 0° and 180°. For the standard variant, actuators are set at 0°, 90° and 180° which is suitable for standard 3-way ball valves. Other positions are available on customer request. These 3 positions are controlled by 4 micro switches (FCO, FCF, FCIO and FCIF) and 3 micro switches for feedback signal.



The terminal temperature can reach 90°C

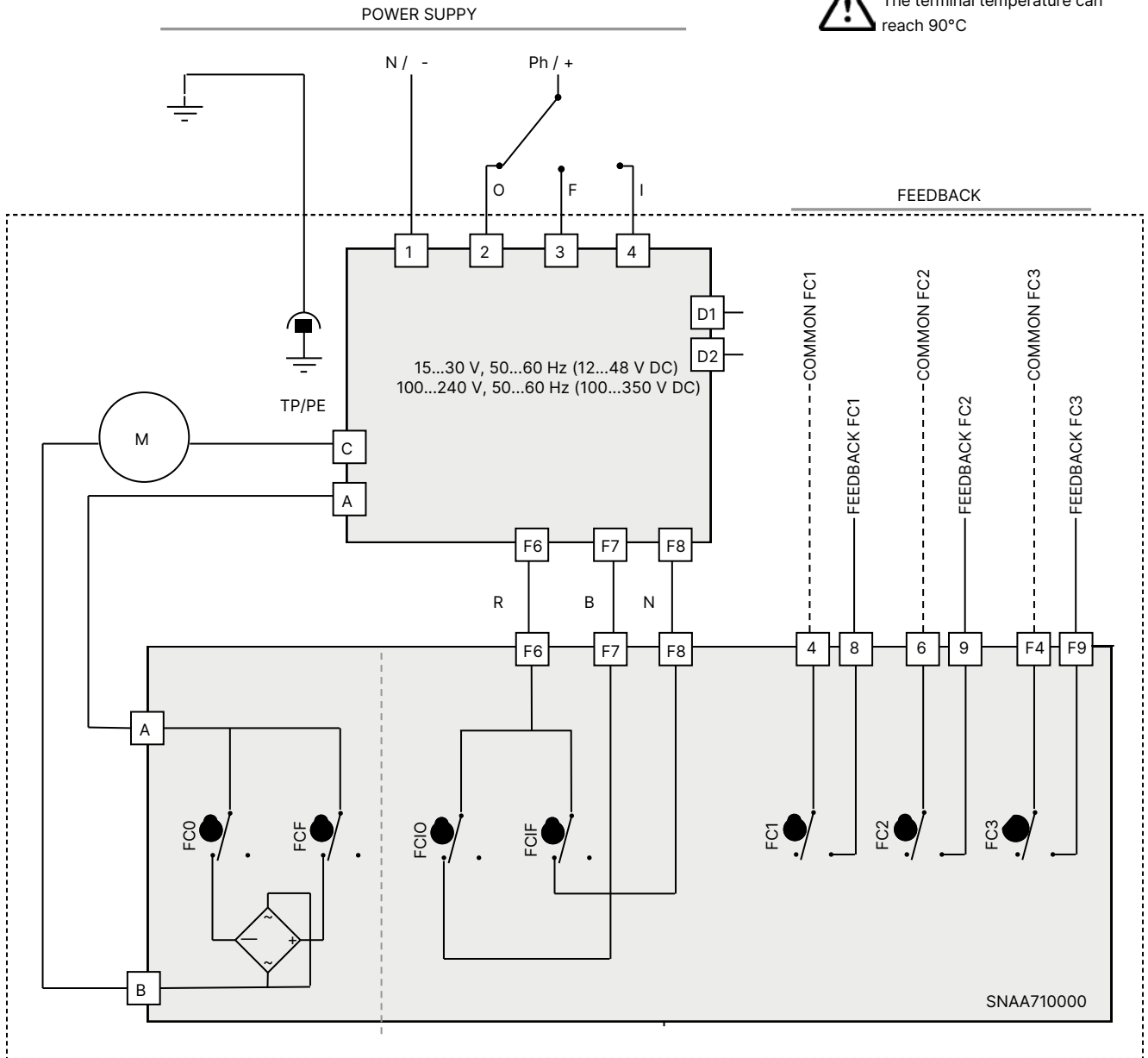

DTS 1000020592 EN Version: AU Status: RL (released | freigegeben | valide) printed: 22.04.2026

	Terminals		
	6 and 9	4 and 8	F4 and F9
0°	Closed	Open	Closed
inter	Open	Open	Open
180°	Open	Closed	Closed

REP	DESIGNATION	REP	DESIGNATION
FCO	Limit switch OPEN	FC1	Auxiliary limit switch 1
FCF	Limit switch CLOSED	FC2	Auxiliary limit switch 2
FCIO	Intermediate limit switch OPEN	FC3	Auxiliary limit switch 3
FCIF	Intermediate limit switch CLOSED	D1/D2	Failure report of terminal strip (24 V DC / 3 A max.)

## 6. Product design and assembly

### 6.1. Product assembly



No.	Element
1	Body
2	Manual override
3	Cover
4	Position indicator
5	Limit switches
6	Terminal strip
7	Cable gland
8	Cable plug
9	Connection flange/removable flange plate (20 Nm only, other interface according to ISO 5211) (only for small motors)

## 7. Ordering information

### 7.1. Bürkert eShop



#### Bürkert eShop – Easy ordering and quick delivery

You want to find your desired Bürkert product or spare part quickly and order directly? Our online shop is available for you 24/7. Sign up and enjoy all the benefits.

[Order online now](#)

### 7.2. Bürkert product filter



**Bürkert product filter – Get quickly to the right product**

You want to select products comfortably based on your technical requirements? Use the Bürkert product filter and find suitable articles for your application quickly and easily.

[Try out our product filter](#)

### 7.3. Ordering chart

#### On/Off variant

Torque <sup>1)</sup>	Double square	Reducing sleeve	Interface according to ISO 5211	90° rotation time		Power consumption	Voltage/frequency	Article no.
				Without load	With load <sup>2)</sup>			
[Nm]	[mm]	[mm]		[s]	[s]	[W]	[V/Hz]	
10	14	14/11 and 14/9	F03/05 resp. F04 <sup>3)</sup>	9	11	15	15...30 V AC, 50...60 Hz, 12...48 V DC	300872
20					12		100...240 V AC, 50...60 Hz, 100...350 V DC	300873
35				19	24		15...30 V AC, 50...60 Hz, 12...48 V DC	225192
	22	22/14	F05/F07	6	26	45	100...240 V AC, 50...60 Hz, 100...350 V DC	225193
60					7		15...30 V AC, 50...60 Hz, 12...48 V DC	20014535
				10	12		100...240 V AC, 50...60 Hz, 100...350 V DC	225194
100		22/17		19	22		15...30 V AC, 50...60 Hz, 12...48 V DC	225195
				20	23		100...240 V AC, 50...60 Hz, 100...350 V DC	225197
							15...30 V AC, 50...60 Hz, 12...48 V DC	225198
							100...240 V AC, 50...60 Hz, 100...350 V DC	225225

- 1.) For the actuator choice, we recommend a safety torque equal to 1.5 times of the valve maximal torque.
- 2.) Other rotation angles are available on request.
- 3.) Replaceable F04 adapter flange enclosed.

#### On/Off variant, long rotation time

Torque <sup>1)</sup>	Double square	Reducing sleeve	Interface according to ISO 5211	90° rotation time		Power consumption	Voltage/frequency	Article no.
				Without load	With load <sup>2)</sup>			
[Nm]	[mm]	[mm]		[s]	[s]	[W]	[V/Hz]	
35	22	22/14	F05/F07	34	41	45	15...30 V AC, 50...60 Hz, 12...48 V DC	227779
60					40		100...240 V AC, 50...60 Hz, 100...350 V DC	231039
				68	79		15...30 V AC, 50...60 Hz, 12...48 V DC	20014536
		22/17		67			100...240 V AC, 50...60 Hz, 100...350 V DC	237538
100				110	119		15...30 V AC, 50...60 Hz, 12...48 V DC	292429
							100...240 V AC, 50...60 Hz, 100...350 V DC	20014537

- 1.) For the actuator choice, we recommend a safety torque equal to 1.5 times of the valve maximal torque.
- 2.) Other rotation angles are available on request.

DTS 1000020592 EN Version: AU Status: RL (released | freigegeben | valide) printed: 22.04.2026

**Control variant with 4...20 mA, 0...20 mA or 0...10 V programmable analogue signal input and output**

Torque <sup>1.)</sup>	Double square	Reducing sleeve	Interface according to ISO 5211	90° rotation time <sup>2.)</sup>	Power consumption	Voltage/frequency	Article no.
[Nm]	[mm]	[mm]		[s]	[W]	[V/Hz]	
20	14	14/11 and 14/9	F03/05 resp. F04 <sup>3.)</sup>	25	15	15...30 V AC, 50...60 Hz, 12...48 V DC	225199
						100...240 V AC, 50...60 Hz, 100...350 V DC	225200
35	22	22/14	F05/F07	40	45	15...30 V AC, 50...60 Hz, 12...48 V DC	225201
						100...240 V AC, 50...60 Hz, 100...350 V DC	225202
60				79		15...30 V AC, 50...60 Hz, 12...48 V DC	225203
						100...240 V AC, 50...60 Hz, 100...350 V DC	225204
100		22/17		119		15...30 V AC, 50...60 Hz, 12...48 V DC	225205
						100...240 V AC, 50...60 Hz, 100...350 V DC	225206

- 1.) For the actuator choice, we recommend a safety torque equal to 1.5 times of the valve maximal torque.
- 2.) Other rotation angles are available on request.
- 3.) Replaceable F04 adapter flange enclosed.

**On/Off variant with emergency reset via integrated battery: fail-to-close/open adjustable<sup>1.)</sup>**

Torque <sup>1.)</sup>	Double square	Reducing sleeve	Interface according to ISO 5211	90° rotation time <sup>2.)</sup>	Power consumption	Voltage/frequency	Article no.
[Nm]	[mm]	[mm]		[s]	[W]	[V/Hz]	
10	14	14/11 and 14/9	F03/05 resp. F04 <sup>4.)</sup>	11	15	15...30 V AC, 50...60 Hz, 24...48 V DC	20014538
						100...240 V AC, 50...60 Hz, 100...350 V DC	20014539
20				12		15...30 V AC, 50...60 Hz, 24...48 V DC	20014540
						100...240 V AC, 50...60 Hz, 100...350 V DC	20014541
35	22	22/14	F05/F07	7	45	15...30 V AC, 50...60 Hz, 24...48 V DC	20014542
						100...240 V AC, 50...60 Hz, 100...350 V DC	20014543
60				12		15...30 V AC, 50...60 Hz, 24...48 V DC	20014544
						100...240 V AC, 50...60 Hz, 100...350 V DC	20014545
100		22/17		23		15...30 V AC, 50...60 Hz, 24...48 V DC	20009903
						100...240 V AC, 50...60 Hz, 100...350 V DC	20014546

- 1.) Default setting: "fail-to-close", can be modified to "fail-to-open" via bluetooth interface and AXMART® App
- 2.) For the actuator choice, we recommend a safety torque equal to 1.5 times of the valve maximal torque.
- 3.) Other rotation angles are available on request.
- 4.) Replaceable F04 adapter flange enclosed.

**On/Off variant with emergency reset via integrated battery: fail-to-close/open adjustable<sup>1.)</sup>, long rotation time**

Torque <sup>1.)</sup>	Double square	Reducing sleeve	Interface according to ISO 5211	90° rotation time <sup>2.)</sup>	Power consumption	Voltage/frequency	Article no.
[Nm]	[mm]	[mm]		[s]	[W]	[V/Hz]	
35	22	22/14	F05/F07	40	45	15...30 V AC, 50...60 Hz, 24...48 V DC	20014547
						100...240 V AC, 50...60 Hz, 100...350 V DC	20014548
60				79		15...30 V AC, 50...60 Hz, 24...48 V DC	20014549
						100...240 V AC, 50...60 Hz, 100...350 V DC	20014550
100		22/17		119		15...30 V AC, 50...60 Hz, 24...48 V DC	20014551
						100...240 V AC, 50...60 Hz, 100...350 V DC	20014552

- 1.) Default setting: "fail-to-close", can be modified to "fail-to-open" via bluetooth interface and AXMART® App
- 2.) For the actuator choice, we recommend a safety torque equal to 1.5 times of the valve maximal torque.
- 3.) Other rotation angles are available on request.

DTS 1000020592 EN Version: AU Status: RL (released | freigegeben | valide) printed: 22.04.2026

3-position variant (0°, 90°, 180°)

Torque <sup>1)</sup>	Double square	Reducing sleeve	Interface according to ISO 5211	90° rotation time <sup>2)</sup>	Power consumption	Voltage/frequency	Article no.
[Nm]	[mm]	[mm]		[s]	[W]	[V/Hz]	
10	14	14/11 and 14/9	F03/05 resp. F04 <sup>3)</sup>	11	15	15...30 V AC, 50...60 Hz, 12...48 V DC	20014553
20				12		100...240 V AC, 50...60 Hz, 100...350 V DC	20014555
35				26		15...30 V AC, 50...60 Hz, 12...48 V DC	267190
	22	22/14	F05/F07	7	45	100...240 V AC, 50...60 Hz, 100...350 V DC	245616
60				12		15...30 V AC, 50...60 Hz, 12...48 V DC	20014558
100				23		100...240 V AC, 50...60 Hz, 100...350 V DC	274694
		22/17				15...30 V AC, 50...60 Hz, 12...48 V DC	20014560
						100...240 V AC, 50...60 Hz, 100...350 V DC	20014560
						15...30 V AC, 50...60 Hz, 12...48 V DC	20007828
						100...240 V AC, 50...60 Hz, 100...350 V DC	237126
						15...30 V AC, 50...60 Hz, 12...48 V DC	226161
						100...240 V AC, 50...60 Hz, 100...350 V DC	226162

- 1.) For the actuator choice, we recommend a safety torque equal to 1.5 times of the valve maximal torque.
- 2.) Other rotation angles are available on request.
- 3.) Replaceable F04 adapter flange enclosed.

3-position variant (0°, 90°, 180°), long rotation time

Torque <sup>1)</sup>	Double square	Reducing sleeve	Interface according to ISO 5211	90° rotation time <sup>2)</sup>	Power consumption	Voltage/frequency	Article no.
[Nm]	[mm]	[mm]		[s]	[W]	[V/Hz]	
35	22	22/14	F05/F07	40	45	15...30 V AC, 50...60 Hz, 12...48 V DC	20014561
60				79		100...240 V AC, 50...60 Hz, 100...350 V DC	20014562
100				119		15...30 V AC, 50...60 Hz, 12...48 V DC	20014563
		22/17				100...240 V AC, 50...60 Hz, 100...350 V DC	20014565
						15...30 V AC, 50...60 Hz, 12...48 V DC	20014566
						100...240 V AC, 50...60 Hz, 100...350 V DC	20014567

- 1.) For the actuator choice, we recommend a safety torque equal to 1.5 times of the valve maximal torque.
- 2.) Other rotation angles are available on request.

**Other variants on request**

	<b>Voltage</b> Other supply voltages
--	---

7.4. Ordering chart accessories

Reducing sleeves

Description	Article no.
Reducing sleeve double square/square 14/9 mm	665288
Reducing sleeve double square/square 14/11 mm	665289
Reducing sleeve square/square 17/14 mm	665290
Reducing sleeve double square/square 17/14 mm	773348
Reducing sleeve double square/square 17/11 mm	773343
Reducing sleeve square/square 22/19 mm	773836
Reducing sleeve double square/square 22/17 mm	684858
Reducing sleeve double square/double square 22/14 mm	666684
Reducing sleeve double square/square 22/11 mm	773344
Reducing sleeve double square/square 27/22 mm	774594
Reducing sleeve square/square 27/19 mm	774279
Reducing sleeve square/square 27/17 mm	774193

**Spare battery for actuators with electronic emergency reset**

**Note:**

- The battery must be replaced after maximum 500 charging cycles or after 2 years at the latest, depending on which condition is reached earlier.
- Additional information for Type 3004: the person who changes the battery must be trained and qualified to do modifications on ATEX products.
- Actuators that do not have an electronic emergency reset when delivered cannot be upgraded with this device at a later date.

**Spare battery for actuator models of the BB40 variant**

Type	Variant	Torque	Article no.
		[Nm]	
3003	BB40	10...100	775335
3004/5	BB40	25...300	774761
3004/5	BB40	600...2400	775337

**Spare battery for older actuator models of the BB31/BB33/GS2 variants**

**Note:**

For older actuators of variants BB31, BB33, and GS2, both the battery and the electronic card of the fail-safe module must be replaced. The article numbers listed below include both components (battery and electronic card). Once the electronic card of the aforementioned BB31, BB33 or GS2 variants has been replaced, the BB40 battery variant can be used for all subsequent replacements.

Type	Variant	Torque	Double square	ISO 5211 interface	Article no.
		[Nm]	[mm]		
3003	BB31/BB33/GS2	10...35	14	F03/05	775680
3003	BB31/BB33/GS2	35...100	22	F05/07	775681
3004/5	BB31/BB33/GS2	25...300	-	-	775682

**Other accessories**

Description	Article no.
Flange plate F04 for small actuator with 10, 20, 35 Nm	665293
Key for adjusting the limit switches	679946

DTS 1000020592 EN Version: AU Status: RL (released | freigegeben | valide) printed: 22.04.2026