



### Tank bottom diaphragm valve with manually operated actuator (basic)

- Valve body and diaphragm are available in different materials and variants
- Product wetted surfaces in  $Ra \leq 0.38 \mu m \dots 1.6 \mu m$  (optionally electropolished)
- Available in all common connection sizes and variants

Product variants described in the data sheet may differ from the product presentation and description.

#### Can be combined with

	<b>Type SV02</b> Diaphragms	▶
	<b>Type 2975</b> Tank bottom diaphragm valve with manually operated actuator (FullFunction)	▶
	<b>Type 2933</b> 2/2-way diaphragm valve with manually operated actuator (basic)	▶
	<b>Type 2934</b> T-diaphragm valve with manually operated actuator (basic)	▶
	<b>Type 2103</b> 2/2-way diaphragm valve with pneumatic stainless steel actuator (Type ELEMENT) for decentralised automation	▶
	<b>Type 8098</b> FLOWave SAW flowmeter	▶

#### Type description

The Type 2935 manually operated diaphragm valve consists of a manually operated actuator, a diaphragm and a tank bottom valve body. The manual actuator with plastic or stainless steel handwheel is available with a diaphragm bonnet made of stainless steel or plastic and ensures use in hygienic or aggressive ambient conditions. The flow-optimised valve body with minimum dead space enables high flow values and a wide range of possible applications. The valve body and the diaphragms are available in all common materials and variants. The actuator has a compact, autoclavable design and is compatible with all other Bürkert diaphragm valves. An explosion-proof ATEX/IECEX device variant is available. The manual actuator is equipped with an integrated visual position indicator, a reproducible stroke scale and an adjustable closing limiter. The manual actuator can optionally be equipped with sensors for position feedback.

DTS 1000584287 EN Version: | Status: RL (released | freigegeben | valide) printed: 25.03.2026

## Table of contents

<b>1. General technical data</b>	<b>3</b>
<hr/>	
<b>2. Approvals and conformities</b>	<b>4</b>
2.1. General notes .....	4
2.2. Conformity .....	4
2.3. Standards .....	4
2.4. Explosion protection .....	4
2.5. Foods and beverages/Hygiene .....	5
2.6. Others .....	5
<hr/>	
<b>3. Materials</b>	<b>6</b>
3.1. Bürkert resistApp .....	6
3.2. Material specifications .....	6
3.3. Example of available diaphragm materials .....	7
<hr/>	
<b>4. Dimensions</b>	<b>8</b>
4.1. Manual actuator .....	8
Diaphragm size 8...25 .....	8
Diaphragm size 40...50 .....	9
Diaphragm size 65...100 .....	10
4.2. Manual actuator with tank bottom body .....	11
4.3. Tank bottom body with welded connection .....	12
4.4. Tank bottom body with clamp connection .....	13
<hr/>	
<b>5. Performance specifications</b>	<b>14</b>
5.1. Medium pressure .....	14
5.2. Tightening torque of the manual drive .....	14
<hr/>	
<b>6. Ordering information</b>	<b>15</b>
6.1. Bürkert eShop .....	15
6.2. Bürkert product filter .....	15
6.3. Bürkert Product Enquiry Form .....	15
6.4. Ordering chart accessories .....	15

## 1. General technical data

Product properties	
Dimensions	Further information can be found in chapter "4. Dimensions" on page 8.
<b>Material<sup>1.)</sup></b>	
Block body (VH) <sup>1.)</sup>	Stainless steel block material 1.4435 according to DIN EN 10088 and 316L according to ASTM A479 / A479M
Block body (VI) <sup>1.)</sup>	Stainless steel block material 1.4435 according to DIN EN 10088 and 316L according to ASME BPE (Table MM-2.1.1, Ed. 2024)
Diaphragm	EPDM (AD) <sup>1.)</sup> , PTFE/EPDM (EA) <sup>1.)</sup> , advanced PTFE/EPDM (EU) <sup>1.)</sup> , laminate of GYLON® and EPDM (ER) <sup>1.)</sup>
Actuator (diaphragm bonnet/handwheel)	Stainless steel/PPS, PPS/PPS, stainless steel/stainless steel
Diaphragm size	8..100
<b>Standard surface quality<sup>2.)</sup></b>	
Block body (VH/VI) <sup>1.)</sup>	Internally electrically polished: Ra ≤ 0.38 µm (NO17) <sup>1.)</sup> (ASME BPE SF4/DIN HE4) (externally: Ra ≤ 1.6 µm) Internally mechanically polished: Ra ≤ 0.5 µm (NO14) <sup>1.)</sup> (ASME BPE SF1) (externally: Ra ≤ 1.6 µm)
Medium data	
Operating medium	Neutral gases and liquids, highly purified, sterile, aggressive or abrasive mediums (see <b>resistance chart</b> ▶)
<b>Medium temperature</b>	
EPDM (AD) <sup>1.)</sup>	-10...+143 °C (steam sterilisation +150 °C for 60 min)
PTFE/EPDM (EA) <sup>1.)</sup>	-10...+130 °C (steam sterilisation +140 °C for 60 min)
Advanced PTFE/EPDM (EU) <sup>1.)</sup>	-5...+143 °C (steam sterilisation +150 °C for 60 min)
Laminate of GYLON® and EPDM (ER) <sup>1.)</sup>	-5...+130 °C (steam sterilisation +140 °C for 60 min)
Product connections	
<b>Port connection<sup>2.)</sup></b>	
Nominal diameter	DN 06...DN 100 (1/8"...4")
<b>Stainless steel body<sup>2.)</sup></b>	
Welded connection <sup>2.)</sup>	DIN EN ISO 1127 / ISO 4200 / DIN 11866 series B DIN 11850 - 2 / DIN 11866 series A / DIN EN 10357 series A ASME BPE / DIN 11866 series C
Clamp connection <sup>2.)</sup>	DIN 32676 series A (DIN pipe) DIN 32676 series B (ISO pipe) ASME BPE
Environment and installation	
Installation position	See <b>operating instructions Type 2935</b> ▶
<b>Ambient temperature: actuator (diaphragm bonnet/handwheel)</b>	
Stainless steel/PPS, PPS/PPS, stainless steel/stainless steel	-10...+130 °C (short-term up to +150 °C), autoclavable

1.) This information is part of the product key (see "6.3. Bürkert Product Enquiry Form" on page 15).

2.) Further variants are available on request.

## 2. Approvals and conformities

### 2.1. General notes

- The approvals and conformities listed below must be stated when making enquiries. This is the only way to ensure that the product complies with all required specifications.
- Not all available variants can be supplied with the below mentioned approvals or conformities.
- Further information can be found in the manufacturer's declarations for our diaphragm valves on our website, see **Type 2935** ▶.



### 2.2. Conformity

In accordance with the Declaration of Conformity, the product is compliant with the EU Directives.

### 2.3. Standards



The applied standards which are used to demonstrate compliance with the EU Directives are listed in the EU-Type Examination Certificate and/or the EU Declaration of Conformity.

### 2.4. Explosion protection

Approval	Description																
 	<p><b>Explosion protection (valid for the variable code PX51)</b> As a category 2 device suitable for zone 1/21 and zone 2/22.</p> <p><b>ATEX:</b> EPS 18 ATEX 2 008 X II 2G Ex h IIC T4...T2 Gb II 2D Ex h IIIC T135 °C...T300 °C Db</p> <p><b>IECEx:</b> IECEx EPS 18.0007X Ex h IIC T4...T2 Gb Ex h IIIC T135 °C...T300 °C Db</p> <table border="1"> <thead> <tr> <th>Temperature class</th> <th>T2</th> <th>T3</th> <th>T4</th> </tr> </thead> <tbody> <tr> <td>Maximum surface temperature</td> <td>+ 300 °C</td> <td>+ 200 °C</td> <td>+ 135 °C</td> </tr> <tr> <td>Ambient temperature</td> <td>- 40...+ 130 °C</td> <td>- 40...+ 130 °C</td> <td>- 40...+ 100 °C</td> </tr> <tr> <td>Maximum medium temperature</td> <td>+ 285 °C</td> <td>+ 185 °C</td> <td>+ 125 °C</td> </tr> </tbody> </table> <p><b>Note:</b> The ambient and medium temperature range may be limited by non-ex-relevant specifications. Observe the operating instructions.</p>	Temperature class	T2	T3	T4	Maximum surface temperature	+ 300 °C	+ 200 °C	+ 135 °C	Ambient temperature	- 40...+ 130 °C	- 40...+ 130 °C	- 40...+ 100 °C	Maximum medium temperature	+ 285 °C	+ 185 °C	+ 125 °C
Temperature class	T2	T3	T4														
Maximum surface temperature	+ 300 °C	+ 200 °C	+ 135 °C														
Ambient temperature	- 40...+ 130 °C	- 40...+ 130 °C	- 40...+ 100 °C														
Maximum medium temperature	+ 285 °C	+ 185 °C	+ 125 °C														

DTS 1000584287 EN Version: | Status: RL (released | freigegeben | valide) printed: 25.03.2026

## 2.5. Foods and beverages/Hygiene

Conformity	Description
	<b>3-A Sanitary Standards Inc. (valid for the variable code PE05)</b> The products comply with 3-A Sanitary Standards Inc (3-A SSI) as per certificate.
FDA	<b>FDA – Code of Federal Regulations</b> The diaphragms made of EPDM (AD), PTFE/EPDM (EA), advanced PTFE/EPDM (EU) and laminate of GYLON® and EPDM (ER) comply with the Code of Federal Regulations published by the FDA (Food and Drug Administration, USA).
USP	<b>United States Pharmacopeial Convention (USP)</b> The diaphragms made of EPDM (AD), PTFE/EPDM (EA), advanced PTFE/EPDM (EU) and laminate of GYLON® and EPDM (ER) are tested according to USP Class VI.
	<b>EC Regulation 1935/2004 of the European Parliament and of the Council</b> The diaphragms made of EPDM (AD), PTFE/EPDM (EA), advanced PTFE/EPDM (EU) and laminate of GYLON® and EPDM (ER) are suitable for use with food and beverages (according to EC Regulation 1935/2004/EC).

## 2.6. Others

Approval	Description
TA Luft	<b>Technical instruction on air quality control (valid for the variable code PM01)</b>

### 3. Materials

#### 3.1. Bürkert resistApp

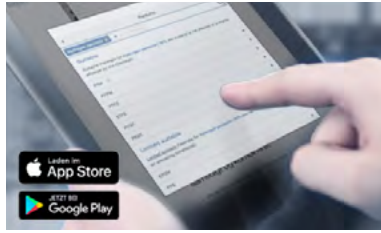

##### Bürkert resistApp – Chemical resistance chart

You want to ensure the reliability and durability of the materials in your individual application case? Verify your combination of media and materials on our website or in our resistApp.

[Start chemical resistance check](#)

#### 3.2. Material specifications

**Note:**

Your product variant may differ from this illustration depending on the body and interface options.

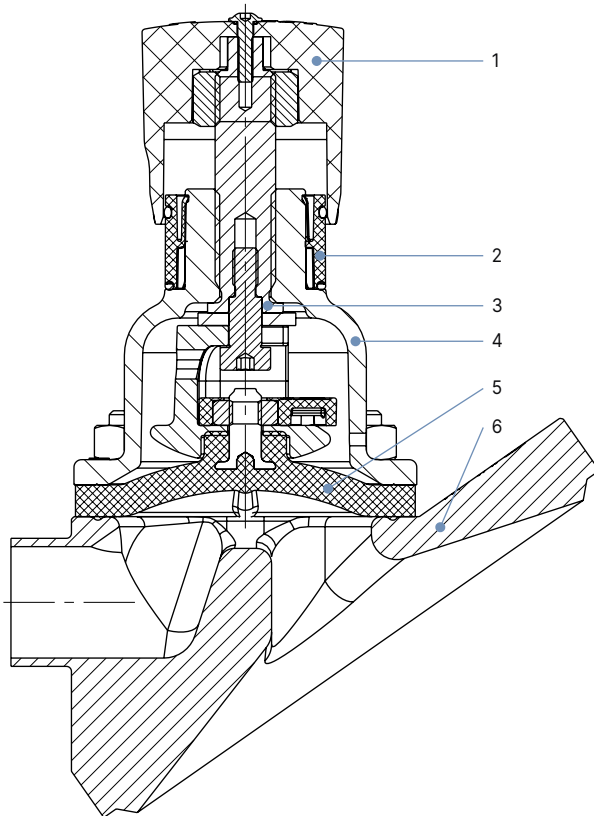

No.	Element	Material
1	Handwheel	Polyphenylene sulphide (PPS), stainless steel 1.4308
2	Visual position indicator	Polyamide (PA), stainless steel 1.4305
3	Valve spindle	Stainless steel 1.4305
4	Diaphragm bonnet	Stainless steel 1.4308, polyphenylene sulphide (PPS)
5	Diaphragm	EPDM (AD), PTFE/EPDM (EA), advanced PTFE/EPDM (EU), laminate of GYLON® and EPDM (ER)
6	Valve body	See "1. General technical data" on page 3.

### 3.3. Example of available diaphragm materials

The diaphragms have been developed to meet the unique challenges of hygienic and sterile requirements. Bürkert offers diaphragms with precise material composition and high accuracy. Bürkert diaphragms are available in a wide range of materials which have been tested and proven in applications in the food and beverage, biotechnology, pharmaceutical and cosmetics industries. The diaphragms are tested during development and production to ensure reliability under difficult process conditions.



- EPDM (AD)
- PTFE/EPDM (EA)
- Advanced PTFE/EPDM (EU)
- Laminate of GYLON® and EPDM (ER)

Further information can be found in our flyer "Diaphragm competence for hygienic applications" on our [website](#) ►.

## 4. Dimensions

### 4.1. Manual actuator

Diaphragm size 8...25

**Note:**

Dimensions in mm, unless otherwise stated

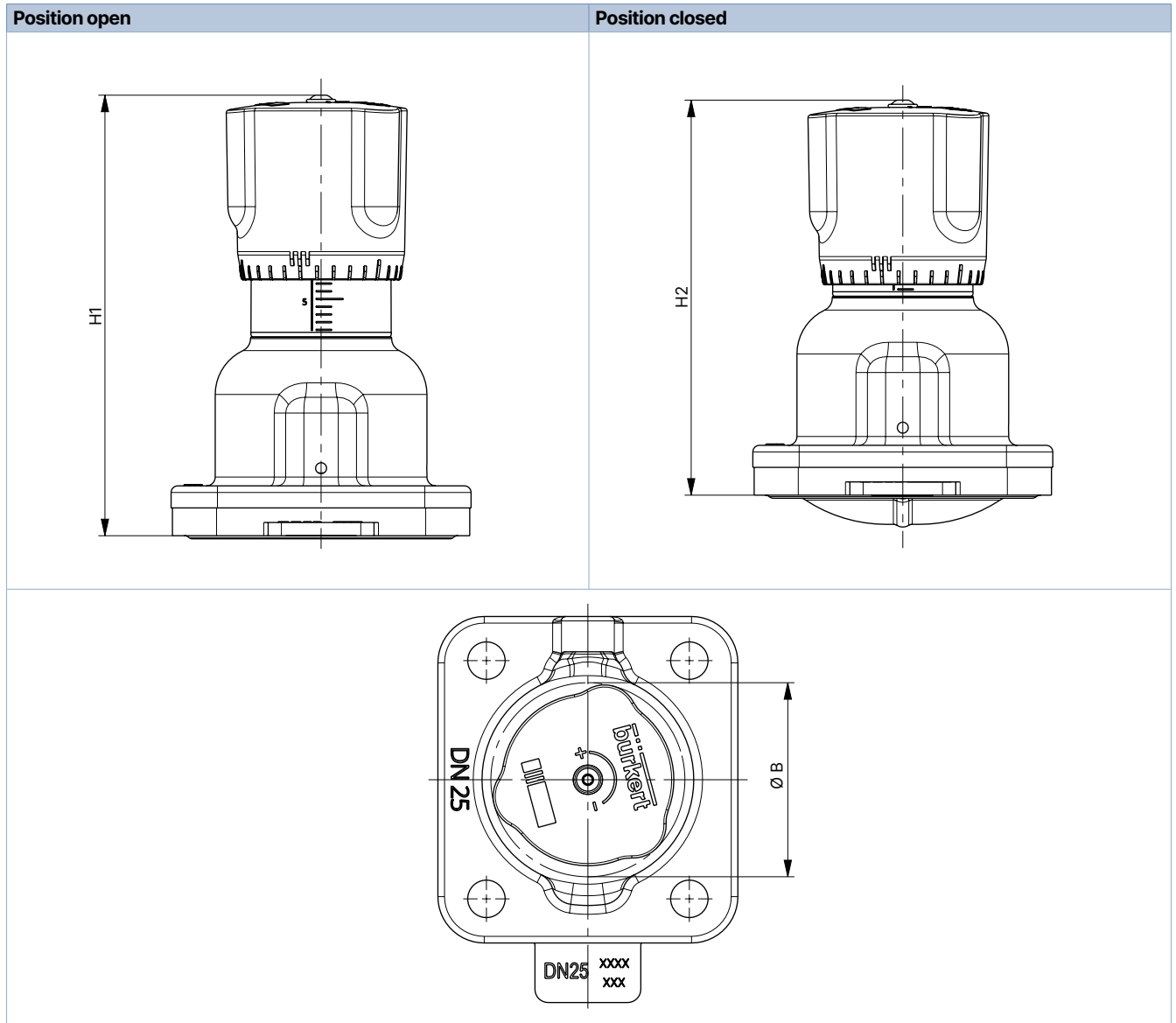

Diaphragm size	H1	H2	Ø B
8	54	49	35
15	84	78	45
20	95	86	45
25	101	90	45

**Diaphragm size 40...50**

**Note:**

Dimensions in mm, unless otherwise stated

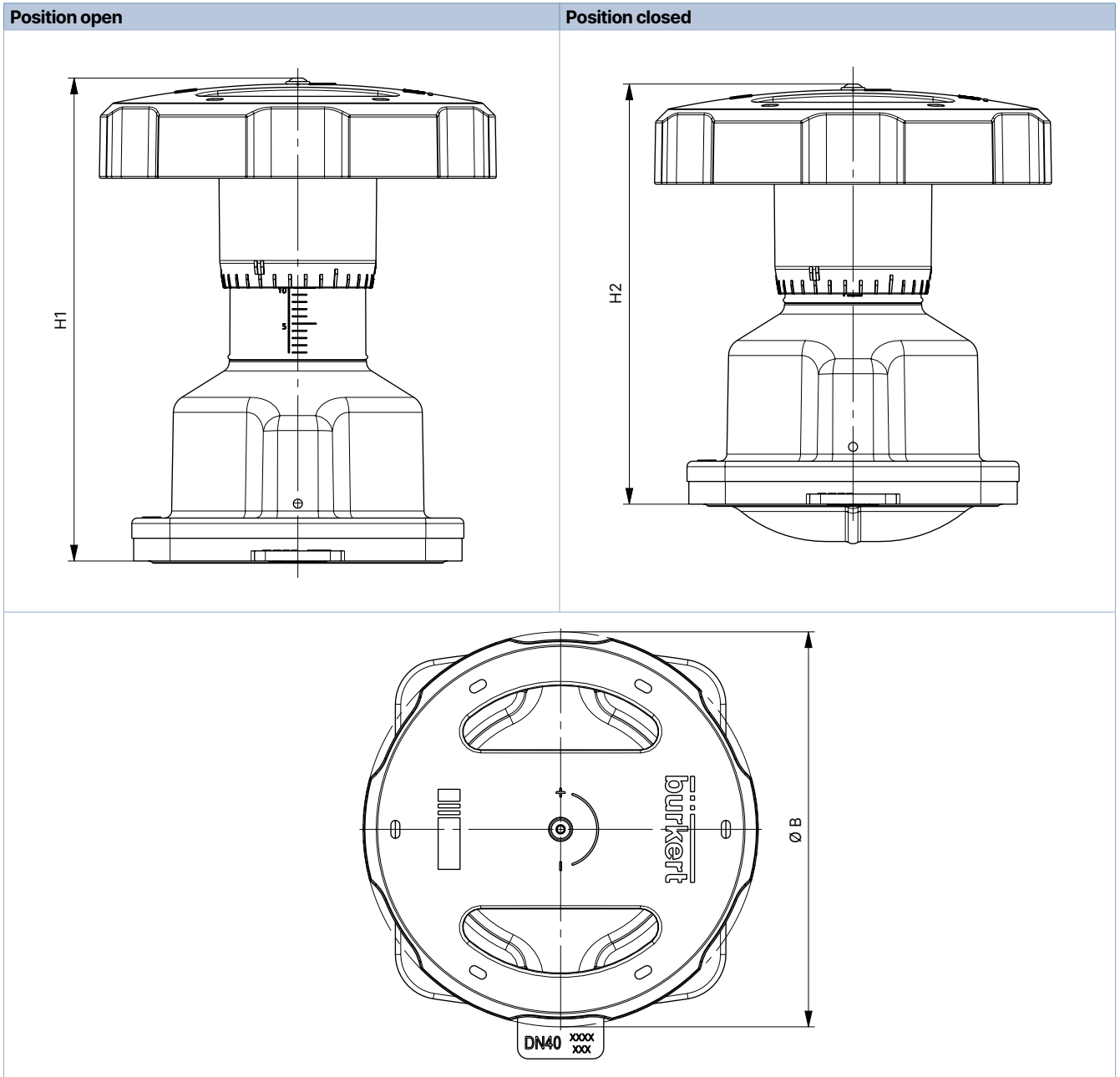

DTS 1000584287 EN Version: | Status: RL (released | freigegeben | valide) printed: 25.03.2026

Diaphragm size	H1	H2	Ø B
40	134	116	110
50	149	125	110

Diaphragm size 65...100

Note:

Dimensions in mm, unless otherwise stated

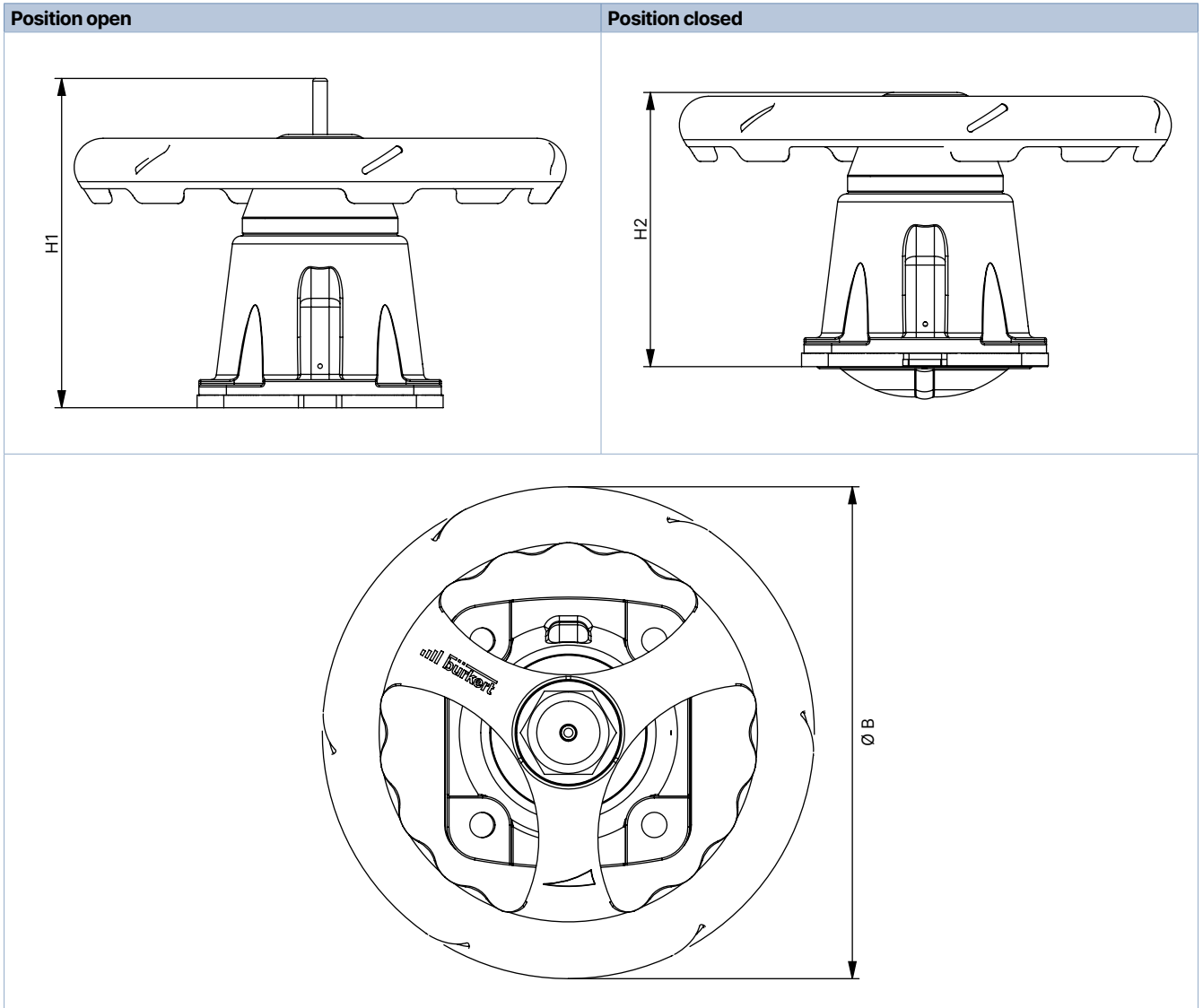

Diaphragm size	H1	H2	Ø B
65	182	152	272
80	205	163	272
100	207	161	272

DTS 1000584287 EN Version: | Status: RL (released | freigegeben | valide) printed: 25.03.2026

#### 4.2. Manual actuator with tank bottom body

**Note:**

Dimensions in mm, unless otherwise stated

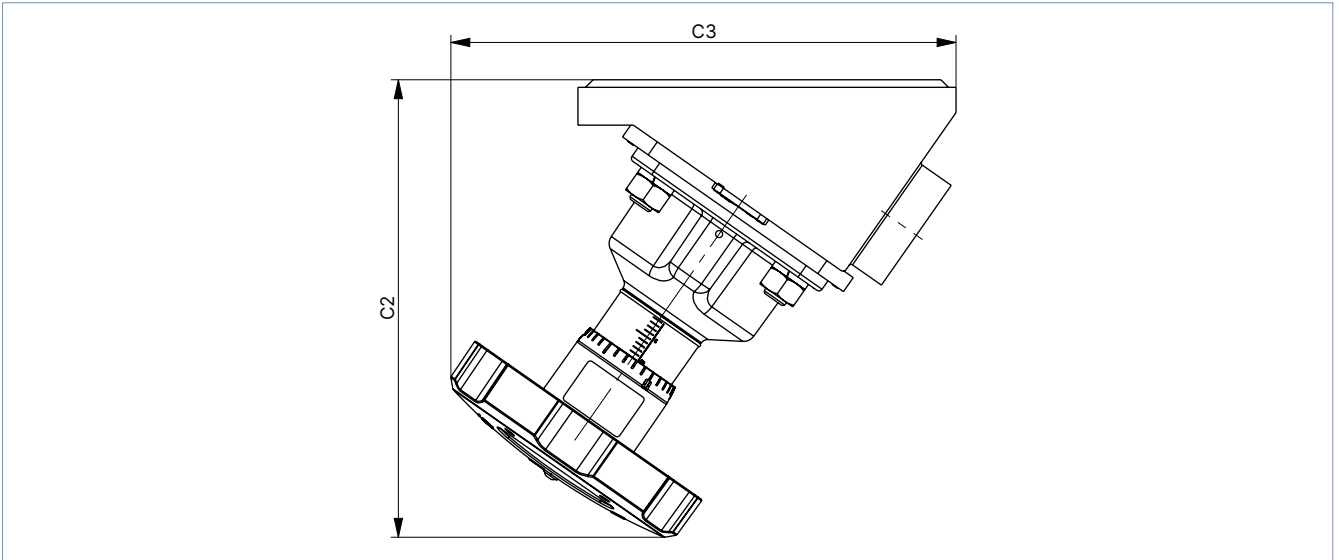

Diaphragm size	C2	C3
8	69	71
15	103	101
20	116	115
25	127	129
40	182	201
50	203	217
65	265	305
80	336	278
100	300	370

### 4.3. Tank bottom body with welded connection

**Note:**

Dimensions in mm, unless otherwise stated

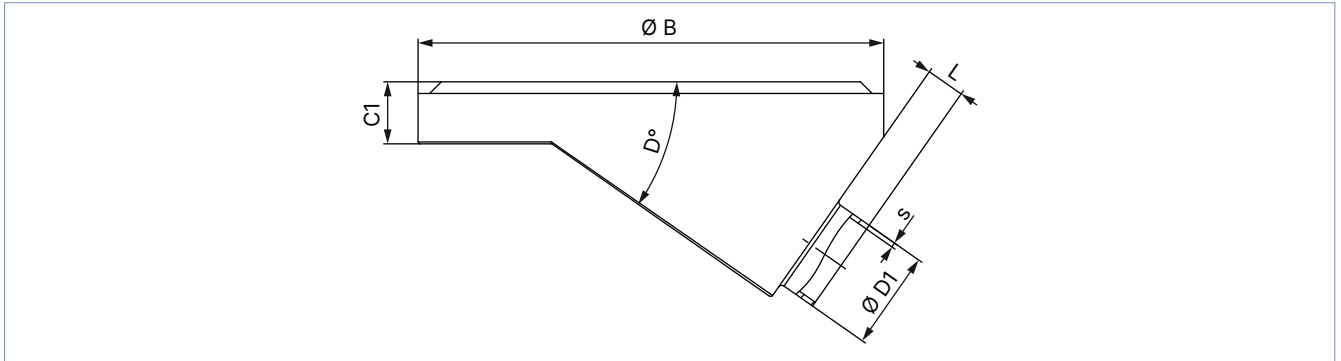

Diaphragm size	Port connection DN/Inch	Ø B	C1	D	Ø D1	s	L	Product key <sup>1)</sup>
<b>DIN EN ISO 1127 / ISO 4200 / DIN 11866 series B</b>								
8	8	50	8	35°	13.5	1.6	5	SA40
15	15	65	12	35°	21.3	1.6	4	SA42
		85					8	SA42
20	20	85	12	35°	26.9	1.6	5.6	SA43
25	25	120	16	35°	33.7	2	8	SA44
40	32	150	18	35°	42.4 (Port 32)	2	20	SA45
	40				48.3		15	SA46
50	50	180	22	35°	60.3	2	12	SA47
80	65	225	20	40°	76.1	2	16	SA48
	80						88.9	2.3
100	100	298	30	40°	114.3	2.3	16.5	SA39
<b>DIN 11850 - 2 / DIN 11866 series A / DIN EN 10357 series A</b>								
8	10	50	8	35°	13	1.5	5	SD40
15	15	85	12	35°	19	1.5	8	SD42
20	20	85	12	35°	23	1.5	7	SD43
25	25	120	16	35°	29	1.5	8	SD44
40	40	150	18	35°	41	1.5	20	SD46
50	50	180	22	35°	53	1.5	15	SD47
80	80	225	20	40°	85	2	16	SD49
100	100	298	30	40°/35°	104	2	14	SD50
<b>ASME BPE / DIN 11866 series C</b>								
8	¼"	50	8	35°	6.35	0.89	6	SA90
15	½"	85	12	35°	12.7	1.65	10	SA92
20	¾"	85	12	35°	19.05	1.65	8	SA93
25	1"	120	16	35°	25.4	1.65	12	SODF
40	1½"	150	18	35°	38.1	1.65	15	SODH
	2"						15	SODI
	2½"						11	SODJ
80	2½"	225	20	40°	63.5	1.65	25	SODJ
	3"						16	SODK
100	4"	298	30	40°	101.6	2.11	14	SODL
<b>SMS 3008</b>								
25	25	120	16	35°	25	1.2	8	SA60
40	40	150	18	35°	38	1.2	20	SA62
50	50	180	22	35°	51	1.2	15	SA63

1.) This information is part of the product key (see "6.3. Bürkert Product Enquiry Form" on page 15).

#### 4.4. Tank bottom body with clamp connection

**Note:**

Clamp dimensions must be added to the welded connection dimensions.

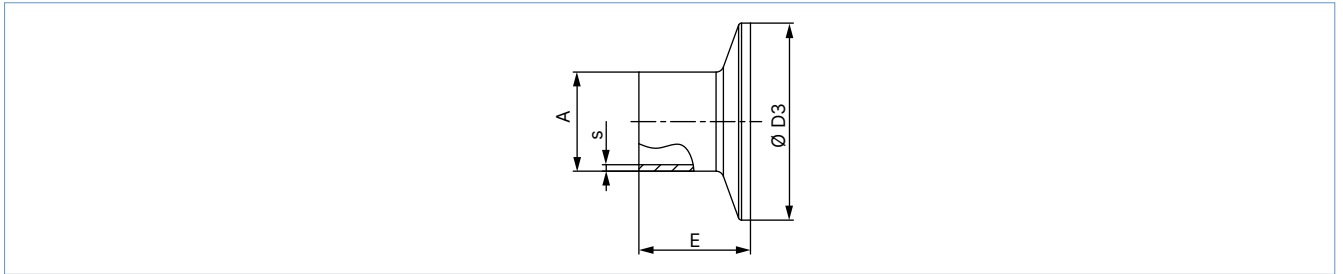

Port connection		A	s	D3	E	Product key <sup>1)</sup>
DN	[inch]	[mm]	[mm]	[mm]	[mm]	
<b>DIN 32676 series A (DIN pipe)</b>						
10	-	13	1.5	34.0	18	TD41
15	-	19	1.5	34.0	18	TD42
20	-	23	1.5	34.0	18	TD43
25	-	29	1.5	50.5	21.5	TD44
32	-	35	1.5	50.5	21.5	TD45
40	-	41	1.5	50.5	21.5	TD46
50	-	53	1.5	64.0	21.5	TD47
65	-	70	2.0	91.0	28.0	TD48
80	-	85	2.0	106.0	28.0	TD49
100	-	104	2.0	119.0	28.0	TD50
<b>DIN 32676 series B (ISO pipe)</b>						
8	-	13.5	1.6	25.0	28.6	TC40
8	-	13.5	1.6	34.0 <sup>2.)</sup>	28.6	TC51 <sup>2.)</sup>
10	-	17.2	1.6	34.0 <sup>2.)</sup>	28.6	TC41 <sup>2.)</sup>
15	-	21.3	1.6	34.0 <sup>2.)</sup>	28.6	TC42 <sup>2.)</sup>
15	-	21.3	1.6	50.5	28.6	TC52
20	-	26.9	1.6	50.5	28.6	TC43
25	-	33.7	2.0	50.5	28.6	TC44
32	-	42.4	2.0	50.5 <sup>2.)</sup>	28.6	TC45 <sup>2.)</sup>
40	-	48.3	2.0	64.0	28.6	TC46
50	-	60.3	2.0	77.5	28.6	TC47
65	-	76.1	2.0	91.0	28.6	TC48
80	-	88.9	2.3	106.0	28.6	TC49
100	-	114.3	2.3	130.0	28.6	TC50
<b>ASME BPE</b>						
8	¼	6.35	0.89	25.0	28.6	TG50
10	⅜	9.53	0.89	25.0	28.6	TG01
15	½	12.7	1.65	25.0	28.6	TG02
20	¾	19.05	1.65	25.0	28.6	TG03
25	1	25.4	1.65	50.5	28.6	TG04
40	1½	38.1	1.65	50.5	28.6	TG05
50	2	50.8	1.65	64.0	28.6	TG06
65	2½"	63.5	1.65	77.5	28.6	TG07
80	3"	76.2	1.65	91.0	28.6	TG08
100	4"	101.6	2.11	119.0	28.6	TG09

1.) This information is part of the product key (see "6.3. Bürkert Product Enquiry Form" on page 15).

2.) Deviating from standard, because of different clamp outer diameter

## 5. Performance specifications

### 5.1. Medium pressure

Diaphragm size	Actuator material (diaphragm bonnet/handwheel)	Operating pressure max. for seal material
		EPDM, PTFE/EPDM, advanced PTFE/EPDM, laminate of GYLON® and EPDM (ER) [bar]
8...80	Stainless steel/stainless steel	10
8...50	Stainless steel/PPS	10
15...40	PPS/PPS	10
50	PPS/PPS	7
100	Stainless steel/stainless steel	6

### 5.2. Tightening torque of the manual drive

**Note:**

- The following tightening torques refer to the static media pressures specified above. Excessive torque can shorten the service life of the diaphragm.
- A tolerance of + 10 % applies to the tightening torques specified.

Diaphragm size	Tightening torque (static media pressure)	
	EPDM [Nm]	PTFE [Nm]
8	0.6	1.1
15	0.8	1.7
20	0.9	3.0
25	1.2	3.5
32	2.5	4.0
40	4.5	7.0
50	6.0	11.0
65	8.0	21.0
80	12.0	23.0
100	11.0	213.0

## 6. Ordering information

### 6.1. Bürkert eShop



#### Bürkert eShop – Easy ordering and quick delivery

You want to find your desired Bürkert product or spare part quickly and order directly? Our online shop is available for you 24/7. Sign up and enjoy all the benefits.

[Order online now](#)

### 6.2. Bürkert product filter



#### Bürkert product filter – Get quickly to the right product

You want to select products comfortably based on your technical requirements? Use the Bürkert product filter and find suitable articles for your application quickly and easily.

[Try out our product filter](#)

### 6.3. Bürkert Product Enquiry Form

**Note:**

Please see our Product Enquiry Form for a full explanation of our specification key.

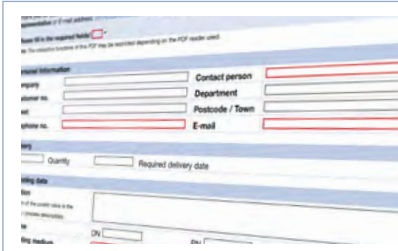

#### Bürkert Product Enquiry Form – Your enquiry quickly and compactly

Would you like to make a specific product enquiry based on your technical requirements? Use our Product Enquiry Form for this purpose. There you will find all the relevant information for your Bürkert contact. This will enable us to provide you with the best possible advice.

[Fill out the form now](#)

### 6.4. Ordering chart accessories

Description	Article no.
4-fold nylon locking mechanism with 3 mm bracket	93719475
Inductive proximity switch (initiator) M5	550412
Inductive proximity switch (initiator) M5 ATEX	904779
Inductive proximity switch (initiator) M8	902475
Inductive proximity switch (initiator) M12	902473

DTS 1000584287 EN Version: | Status: RL (released | freigegeben | valide) printed: 25.03.2026