





Direct-acting 2 way standard solenoid control valve

- Excellent range
- Very good response
- Compact valve design
- Orifice sizes 2...9.5 mm
- Optional: Explosion-protected coil



Product variants described in the data sheet may differ from the product presentation and description.

Can be combined with

	Type 8605 PWM control electronics for electromagnetic proportional valves	▶
	Type 2518 Cable plug, form A according to DIN EN 175301-803	▶
	Type 8611 eCONTROL – Universal controller	▶

Type description

The direct-acting solenoid control valve Type 2875 is used as the regulating unit in control loops. Due to an elastomeric seat seal the valve closes tight (integrated shut-off function), up to the DN specific nominal pressure. The plunger of the valve is assembled frictionless, which leads to an extraordinary adjustment characteristic. This valve is particularly suitable for demanding control tasks (high control range, dry gases, etc.).

DTS 1000593845 EN Version: H Status: RL (released | freigegeben | valide) printed: 16.03.2026

Table of contents

1. General technical data	3
2. Circuit functions	3
3. Approvals and conformities	4
3.1. General notes	4
3.2. Conformity	4
3.3. Standards	4
3.4. Explosion protection.....	4
3.5. North America (USA/Canada)	4
3.6. Foods and beverages/Hygiene	4
4. Materials	5
4.1. Bürkert resistApp	5
5. Dimensions	6
5.1. Standard variant.....	6
Threaded variant.....	6
Sub-base variant	7
5.2. ATEX variant.....	8
Threaded variant.....	8
Sub-base variant	9
6. Performance specifications	9
6.1. Flow characteristic	9
Determination of the K_v value.....	9
6.2. Exemplary characteristic curve of a proportional valve	10
7. Product operation	10
7.1. Control unit	10
8. Ordering information	11
8.1. Bürkert eShop	11
8.2. Recommendation regarding product selection.....	11
8.3. Bürkert product filter.....	11
8.4. Bürkert Product Enquiry Form	11
8.5. Ordering chart	12
Standard variant.....	12
Variant with ATEX/IECEX approval	12
Variant for higher differential pressures	13
Variant for higher differential pressures with ATEX/IECEX approval.....	13
8.6. Ordering chart accessories.....	14
Cable plug Type 2518, form A according to DIN EN 175301 - 803	14
Control electronics Type 8605 for proportional valves	15

1. General technical data

Product properties	
Dimensions	Further information can be found in chapter "5. Dimensions" on page 6.
Material	
Seal	FKM, EPDM
Body	Brass, stainless steel
Circuit function	A Further information can be found in chapter "2. Circuit functions" on page 3.
Performance data	
Typical values of positioning behaviour ^{1.)}	
Hysteresis	< 5 %
Repeat accuracy	< 0.5 % FS ^{2.)}
Response sensitivity	< 0.25 % FS ^{2.)}
Setting range	1:200
Actuating time (10...90 %)	< 25 ms
Pressure range ^{3.)}	0...363 psi
Duty cycle	100 % continuous operation
Electrical data	
Operating voltage	24 V DC (12 V on request)
Power consumption	16 W
Maximum coil current ^{4.)}	750 mA (at 16 W and 24 V coil)
PWM frequency ^{5.)}	900 Hz
Medium data	
Operating medium	Neutral gases, liquids on request
Medium temperature	+ 14 °F...+ 194 °F (with FKM) - 22 °F...+ 194 °F (with EPDM)
Viscosity	Max. 21 mm ² /s (21 cSt)
Product connections	
Electrical connection	Cable plug Type 2518 ▶, form A according to DIN EN 175301 - 803 Further information can be found in chapter "Cable plug Type 2518, form A according to DIN EN 175301 - 803" on page 14.
Port connection size	Sub-base, G 3/8, G 1/2, NPT 3/8, NPT 1/2
Approvals and conformities	
Degree of protection	IP65
Explosion protection	Further information can be found in chapter "3.4. Explosion protection" on page 4.
North America (USA/Canada)	Further information can be found in chapter "3.5. North America (USA/Canada)" on page 4.
Foods and beverages/Hygiene	Further information can be found in chapter "3.6. Foods and beverages/Hygiene" on page 4.
Environment and installation	
Installation position	As required, preferably with actuator upright
Ambient temperature	Max. + 131 °F

1.) Characteristic data of control behaviour depends on process conditions

2.) With flow measurement

3.) Pressure data: overpressure to atmospheric pressure, depending on nominal diameter, tightness seal or nominal pressure

4.) Maximum value: value depends on operating pressure

5.) PWM: pulse-width modulation

2. Circuit functions

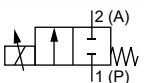
Symbol	Description
	Circuit function A (CF A) 2/2-way solenoid proportional control valve Direct-acting Normally closed

3. Approvals and conformities

3.1. General notes

- The approvals and conformities listed below must be stated when making enquiries. This is the only way to ensure that the product complies with all required specifications.
- Not all available variants can be supplied with the below mentioned approvals or conformities.

3.2. Conformity

In accordance with the Declaration of conformity, the product is compliant with the EU Directives.

3.3. Standards

The applied standards which are used to demonstrate compliance with the EU Directives are listed in the EU-Type Examination Certificate and/or the EU Declaration of Conformity.

3.4. Explosion protection

Approval	Description
 	<p>Optional: Explosion protection</p> <p>ATEX: II 2 G Ex mb IIC T4 Gb II 2 D Ex mb IIIC T130 °C Db</p> <p>IECEX: Ex mb IIC T4 Gb Ex mb IIIC T130 °C Db</p>

3.5. North America (USA/Canada)

Approval	Description
	<p>Optional: UL Recognized for the USA ¹⁾ The products are UL Recognized for the USA according to:</p> <ul style="list-style-type: none"> • UL 429 (Electrically operated valves)

1.) This device is intended to be used with a NEC Class 2 power source or NEC Class 2 transformer in accordance with UL1310 or UL1585.

3.6. Foods and beverages/Hygiene

Conformity	Description
<p>USP</p>	<p>United States Pharmacopeial Convention (USP) (valid for the variable code PL04) All wetted materials are biocompatible according to the manufacturer's declaration.</p>
<p>FDA</p>	<p>FDA – Code of Federal Regulations (valid for the variable code PL02, PL03) All wetted materials are compliant with the Code of Federal Regulations published by the FDA (Food and Drug Administration, USA) according to the manufacturer's declaration.</p>
	<p>EC Regulation 1935/2004 of the European Parliament and of the Council (valid for the variable code PL01, PL02) All wetted materials are compliant with EC Regulation 1935/2004/EC according to the manufacturer's declaration.</p>

DTS 1000593845 EN Version: H Status: RL (released | freigegeben | valide) printed: 16.03.2026

4. Materials

4.1. Bürkert resistApp

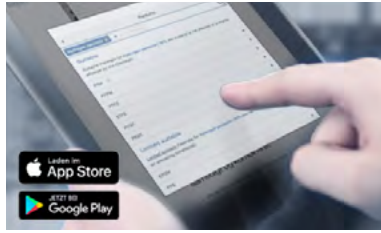

Bürkert resistApp – Chemical resistance chart

You want to ensure the reliability and durability of the materials in your individual application case? Verify your combination of media and materials on our website or in our resistApp.

[Start chemical resistance check](#)

Sub-base variant

Note:

Dimensions in mm [inch]

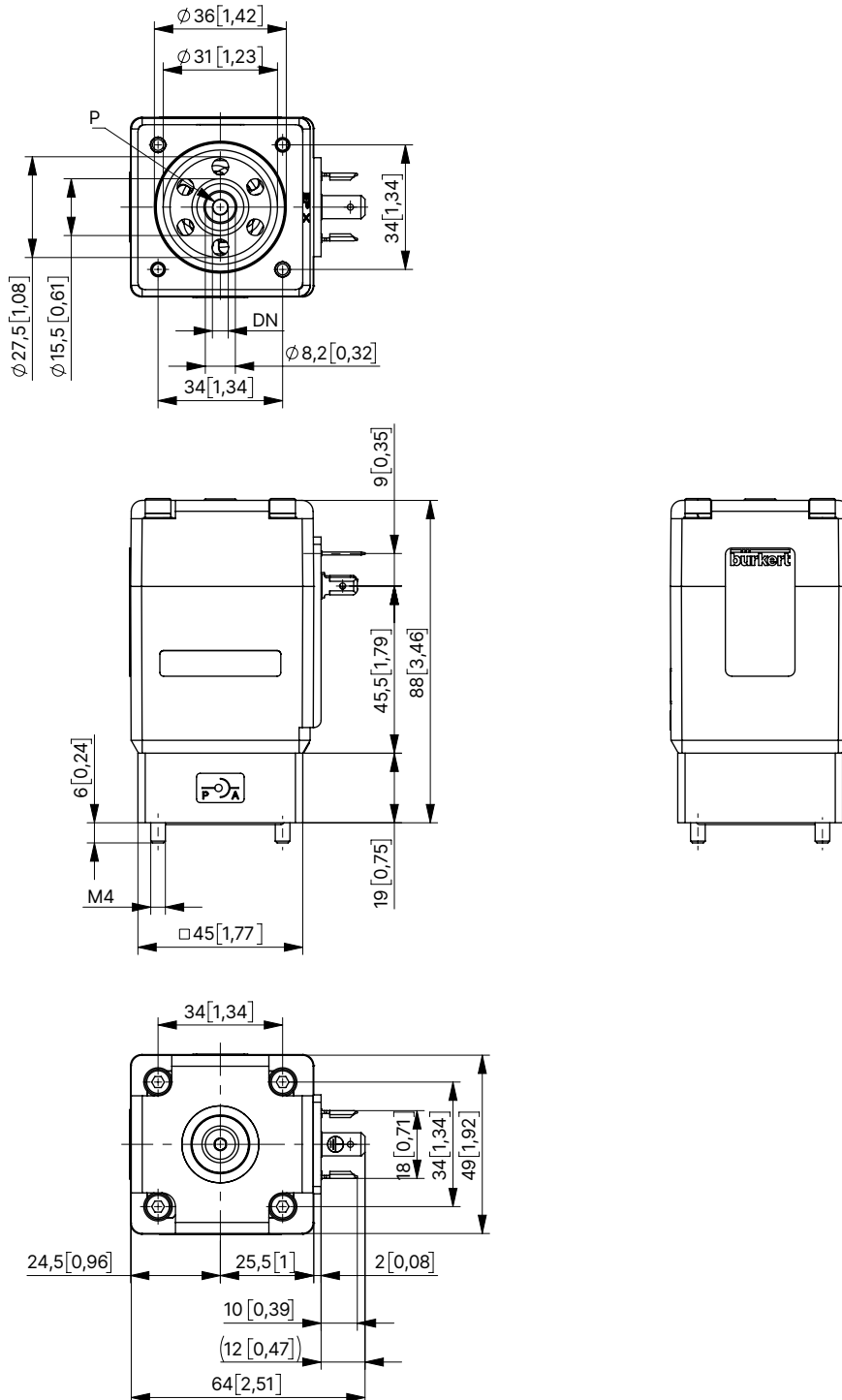

DTS 1000593845 EN Version: H Status: RL (released | freigegeben | valide) printed: 16.03.2026

Sub-base variant

Note:

Dimensions in mm [inch]

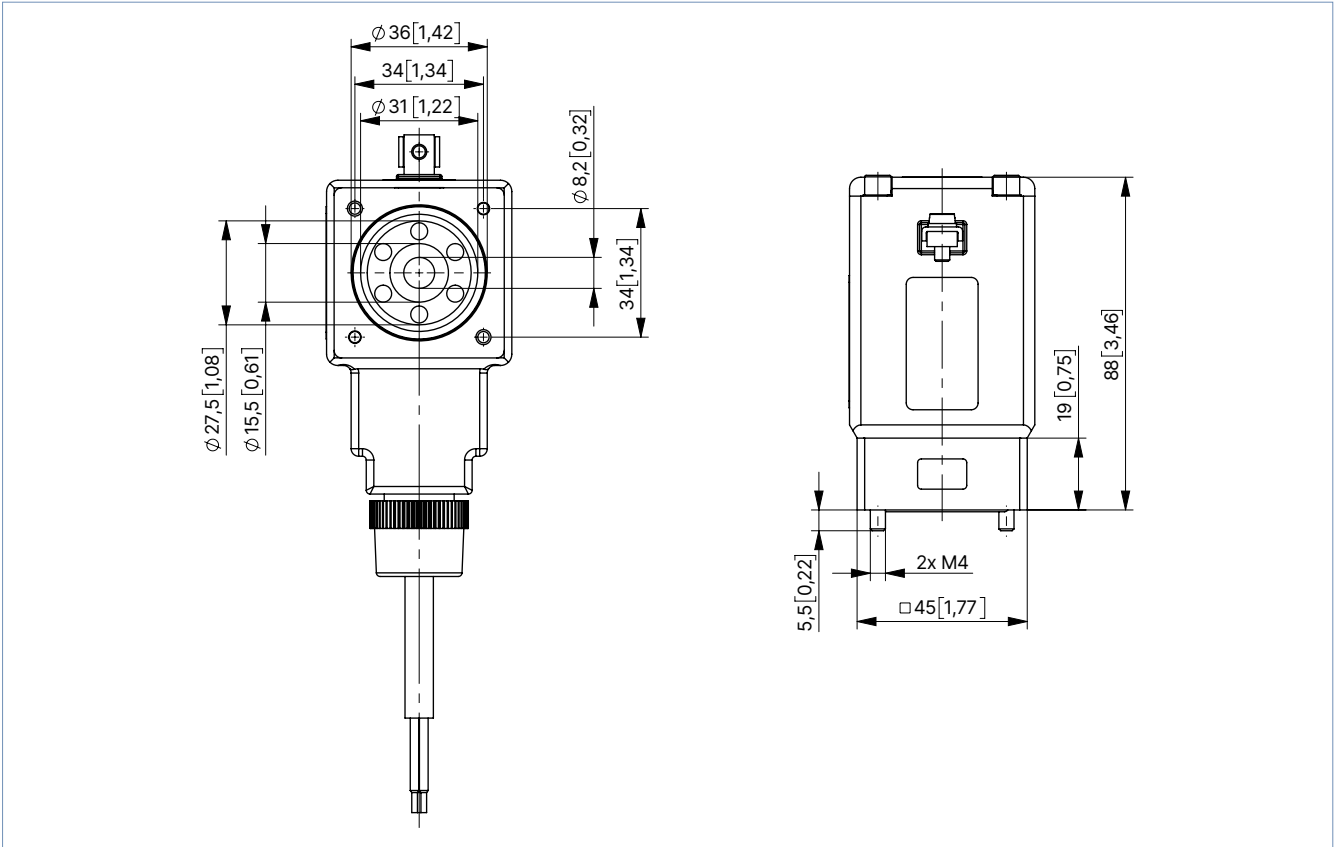

6. Performance specifications

6.1. Flow characteristic

Determination of the K_v value

Pressure drop	K_v value for liquids [m ³ /h]	K_v value for gases [m ³ /h]
Sub-critical $p_2 > \frac{p_1}{2}$	$= Q \sqrt{\frac{\rho}{1000 \Delta p}}$	$= \frac{Q_N}{514} \sqrt{\frac{T_1 \rho_N}{p_2 \Delta p}}$
Supercritical $p_2 < \frac{p_1}{2}$	$= Q \sqrt{\frac{\rho}{1000 \Delta p}}$	$= \frac{Q_N}{257 p_1} \sqrt{T_1 \rho_N}$

Value	Description	Unit
K_v	Flow coefficient	[m ³ /h] ^{1.)}
Q_N	Standard flow rate	[m ³ /h] ^{2.)}
p_1	Inlet pressure	[bar] ^{3.)}
p_2	Outlet pressure	[bar] ^{3.)}
Δp	Differential pressure $p_1 \dots p_2$	[bar]
ρ	Density	[kg/m ³]
ρ_N	Standard density	[kg/m ³]
T_1	Medium temperature	[(273+t)K]

1.) Measured for water, $\Delta p = 1$ bar, over the value

2.) At reference conditions 1.013 bar and 0 °C (273 K)

3.) Absolute pressure

6.2. Exemplary characteristic curve of a proportional valve

Note:

The dimensioning of the nominal diameter is very important for proportional valves to function properly within the application. The nominal diameter must be selected so that, on the one hand, the desired flow range is achieved and, on the other hand, when the valve is fully open, a sufficient portion of the total pressure drop occurs across the valve.

Reference value: $\Delta p_{\text{valve}} > 25\%$ of the total pressure drop

Otherwise, an ideal, linear valve characteristic is deformed into a curved system characteristic.

If the differential pressure (difference between inlet and outlet pressure) exceeds half the value of the nominal pressure discontinuities may occur.

For that reason take advantage of Bürkert competent engineering services during the planning phase.

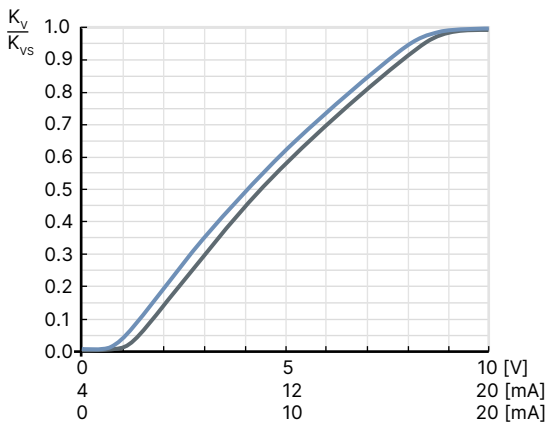

7. Product operation

7.1. Control unit

Valve control takes place through a PWM signal (pulse-width modulation). The duty cycle of the PWM signal determines the coil current and hence the position of the plunger.

The Bürkert control electronics Type 8605 (see data sheet **Type 8605** ▶) converts an analogue signal to a reference value corresponding to the valve type PWM signal and provides additional functions such as temperature compensation (coil heating), ramp function and the adjustment of minimum and maximum duty cycle/coil current for the control range.

Please note the sizing comments for such a control valve in chapter **“6.2. Exemplary characteristic curve of a proportional valve” on page 10.**

DTS 1000593845 EN Version: H Status: RL (released | freigegeben | valide) printed: 16.03.2026

8. Ordering information

8.1. Bürkert eShop



Bürkert eShop – Easy ordering and quick delivery

You want to find your desired Bürkert product or spare part quickly and order directly? Our online shop is available for you 24/7. Sign up and enjoy all the benefits.

[Order online now](#)

8.2. Recommendation regarding product selection

Note:

- Use the product enquiry form (see “8.4. Bürkert Product Enquiry Form” on page 11) for information about the device layout and send it to us after completion.
- Please note the chapter “6.2. Exemplary characteristic curve of a proportional valve” on page 10 on product selection.

8.3. Bürkert product filter



Bürkert product filter – Get quickly to the right product

You want to select products comfortably based on your technical requirements? Use the Bürkert product filter and find suitable articles for your application quickly and easily.

[Try out our product filter](#)

8.4. Bürkert Product Enquiry Form

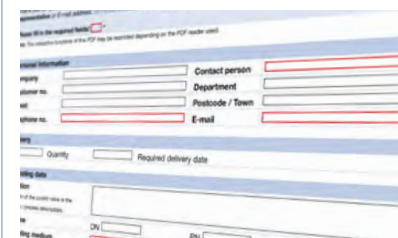

Bürkert Product Enquiry Form – Your enquiry quickly and compactly

Would you like to make a specific product enquiry based on your technical requirements? Use our Product Enquiry Form for this purpose. There you will find all the relevant information for your Bürkert contact. This will enable us to provide you with the best possible advice.

[Fill out the form now](#)

DTS 1000593845 EN Version: H Status: RL (released | freigegeben | valide) printed: 16.03.2026

8.5. Ordering chart

Standard variant

Note:

- All valves with FKM seals and UL Recognized approval
- Other connection variants (Sub-base, G) on request
- Please note that the cable plug must be ordered separately, see [“Cable plug Type 2518, form A according to DIN EN 175301-803” on page 14](#) or separate data sheet for **Type 2518** ▶

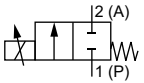
Circuit function	Port connection ^{1.)}	Orifice	C _{vs} value water ^{2.)}	Nominal pressure ^{3.)} (MAWP ^{4.)})	Maximum differential pressure (MAOP ^{5.)})	Article no. Brass body	Article no. Stainless steel body
		[mm]	[gal/min]	[psi]	[psi]		
CF A 2/2-way solenoid proportional control valve Direct-acting Normally closed 	NPT 3/8	2.0	0.14	363	181	274977 ☒	274989 ☒
	NPT 3/8	3.0	0.29	145	73	274979 ☒	274991 ☒
	NPT 3/8	4.0	0.52	116	58	274981 ☒	274993 ☒
	NPT 1/2		0.52	116	58	274983 ☒	274995 ☒
	NPT 1/2	6.0	0.93	58	29	274985 ☒	274997 ☒
	NPT 1/2	8.0	1.27	29	15	274987 ☒	274999 ☒
	NPT 1/2	9.5	1.62	10	5	20071284 ☒	20071285 ☒

- 1.) Port connection: others on request
- 2.) Measurement at + 68 °F, 14.5 psi pressure differential over a fully opened valve.
- 3.) Pressure data: overpressure to atmospheric pressure. If the differential pressure between the inlet and outlet pressure of the valve is greater than half of the nominal pressure, discontinuities in the valve characteristic curve are possible.
- 4.) Maximum allowable working pressure
- 5.) Maximum allowable operating pressure

Variant with ATEX/IECEx approval

Note:

- All valves with FKM seals and ATEX/IECEx variant with 3 m connection cable.
- Other connection variants (Sub-base, G) or stainless steel body on request
- Refer to chapter [“3. Approvals and conformities” on page 4](#) for more information about the approvals.

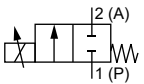
Circuit function	Port connection ^{1.)}	Orifice	C _{vs} value water ^{2.)}	Nominal pressure ^{3.)} (MAWP ^{4.)})	Maximum differential pressure (MAOP ^{5.)})	Article no. Brass body
		[mm]	[gal/min]	[psi]	[psi]	
CF A 2/2-way solenoid proportional control valve Direct-acting Normally closed 	NPT 3/8	2.0	0.14	290	145	20062687 ☒
	NPT 3/8	3.0	0.29	131	65	20062688 ☒
	NPT 3/8	4.0	0.52	102	51	20062690 ☒
	NPT 1/2		0.52	102	51	20062691 ☒
	NPT 1/2	6.0	0.93	51	25	20062694 ☒
	NPT 1/2	8.0	1.27	22	11	20062695 ☒

- 1.) Port connection: others on request
- 2.) Measurement at + 68 °F, 14.5 psi pressure differential over a fully opened valve.
- 3.) Pressure data: overpressure to atmospheric pressure. If the differential pressure between the inlet and outlet pressure of the valve is greater than half of the nominal pressure, discontinuities in the valve characteristic curve are possible.
- 4.) Maximum allowable working pressure
- 5.) Maximum allowable operating pressure

DTS 1000593845 EN Version: H Status: RL (released | freigegeben | valide) printed: 16.03.2026

Variant for higher differential pressures

Note:

- All valves with FKM seals and UL Recognized approval
- Other connection variants (Sub-base, G) on request
- PWM frequency: 500 Hz
- Setting range: 1:100
- For $\Delta p > 145$ psi it is possible to get inconsistencies in the characteristic curve because of flow conditions in the application.
- Please note that the cable plug must be ordered separately, see ["Cable plug Type 2518, form A according to DIN EN 175301-803"](#) on [page 14](#) or separate data sheet for [Type 2518](#) ▶.
- Refer to chapter ["3. Approvals and conformities"](#) on [page 4](#) for more information about the approvals.

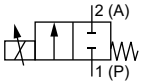
Circuit function	Port connection ^{1.)}	Orifice	C _{vs} value water ^{2.)}	Nominal pressure ^{3.)} (MAWP ^{4.)})	Article no. Brass body	Article no. Stainless steel body
		[mm]	[gal/min]	[psi]		
CF A 2/2-way solenoid proportional control valve Direct-acting Normally closed 	NPT 3/8	2.0	0.14	363	20062702	20062703
	NPT 3/8	3.0	0.29	145	20062704	20062705
	NPT 3/8	4.0	0.52	116	20062706	20062707
	NPT 1/2		0.52	116	20062708	20062710
	NPT 1/2	6.0	0.93	58	20062711	20062713
	NPT 1/2	8.0	1.27	29	20062714	20062715
	NPT 1/2	9.5	1.62	10	20062716	20062717

- 1.) Port connection: others on request
- 2.) Measurement at + 68 °F, 14.5 psi pressure differential over a fully opened valve.
- 3.) Pressure data: overpressure to atmospheric pressure. If the differential pressure between the inlet and outlet pressure of the valve is greater than half of the nominal pressure, discontinuities in the valve characteristic curve are possible.
- 4.) Maximum allowable working pressure

Variant for higher differential pressures with ATEX/IECEX approval

Note:

- All valves with FKM seals and ATEX/IECEX variant with 3 m connection cable.
- Other connection variants (Sub-base, G) or stainless steel body on request
- PWM frequency: 500 Hz
- Setting range: 1:100
- For $\Delta p > 145$ psi it is possible to get inconsistencies in the characteristic curve because of flow conditions in the application.
- Refer to chapter ["3. Approvals and conformities"](#) on [page 4](#) for more information about the approvals.

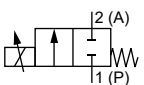
Circuit function	Port connection ^{1.)}	Orifice	C _{vs} value water ^{2.)}	Nominal pressure ^{3.)} (MAWP ^{4.)})	Article no. Brass body
		[mm]	[gal/min]	[psi]	
CF A 2/2-way solenoid proportional control valve Direct-acting Normally closed 	NPT 3/8	2.0	0.14	290	20062696
	NPT 3/8	3.0	0.29	131	20062697
	NPT 3/8	4.0	0.52	102	20062698
	NPT 1/2		0.52	102	20062699
	NPT 1/2	6.0	0.93	51	20062700
	NPT 1/2	8.0	1.27	22	20062701

- 1.) Port connection: others on request
- 2.) Measurement at + 68 °F, 14.5 psi pressure differential over a fully opened valve.
- 3.) Pressure data: overpressure to atmospheric pressure. If the differential pressure between the inlet and outlet pressure of the valve is greater than half of the nominal pressure, discontinuities in the valve characteristic curve are possible.
- 4.) Maximum allowable working pressure

DTS 1000593845 EN Version: H Status: RL (released | freigegeben | valide) printed: 16.03.2026

Further variants on request			
	Material EPDM		Analytical Oxygen variant, parts oil-, fat- and silicon free
	Approval Further information can be found in chapter "3. Approvals and conformities" on page 4.		Process connection Sub-base variant

8.6. Ordering chart accessories

Cable plug Type 2518, form A according to DIN EN 175301 - 803

Note:

For further variants see data sheet **Type 2518** ▶.



Cable plug	Dimensions	Variant	Voltage	Article no.
		Without wiring (AC/DC)	0...250 V AC/DC	314802 𠄎

DTS 1000593845 EN Version: H Status: RL (released | freigegeben | valide) printed: 16.03.2026

Control electronics Type 8605 for proportional valves

Note:

Refer to data sheet **Type 8605** ▶ for more information about the control electronics.

Control electronics	Variant	Max. coil current range [mA]	Voltage		Article no.
			24 V DC	12 V DC	
	Cable plug with PG cable gland	200...1000	X	–	316530
	Cable plug with M12 connection	200...1000	X	–	316528
	Cable plug with PG cable gland	500...2000	X	X	316529
	Cable plug with M12 connection	500...2000	X	X	316526
	Cable plug with PG cable gland without operating unit	200...1000	X	–	316521
	Cable plug with M12 connection without operating unit	200...1000	X	–	316522
	Cable plug with PG cable gland without operating unit	500...2000	X	X	316523
	Cable plug with M12 connection without operating unit	500...2000	X	X	316525
	Standard rail	200...1000	X	–	316532
	Standard rail	500...2000	X	X	316533

X = available
 – = not available

DTS 1000593845 EN Version: H Status: RL (released | freigegeben | valide) printed: 16.03.2026