



2/2-way stainless steel ball valve three pieces

- Investment cast stainless steel
- Blow-out proof stem with adjustable packing
- Long service life
- Manual and ISO 5211 mounting flange versions

Product versions described in the data sheet may differ from the product presentation and description.

Can be combined with

	Type 2051 Pneumatic rotary actuator	▶
	Type 2053 Pneumatic rotary actuator for the automation of ball and butterfly valves	▶
	Type 3003 Electrical Rotary Actuator – On/Off and control	▶
	Type 3005 Electric Rotary Actuator – On/Off and Control	▶
	Type 3004 Explosion-Proof Rotary Actuator – On/Off or Control	▶
	Type 1061 Position feedback unit for pneumatic rotary actuators	▶
	Type 8692 Digital electro-pneumatic positioner for integrated mounting on process control valves	▶

Type description

The 2/2-way ball valve design is an industry proven three piece investment cast body and ends. It finds wide use in fluid media while offering higher cycle life with reduced torque. The self-adjusting packing gland is a dual sealing type with an alignment collar for superior tightness.

The automation ready version has an ISO 5211 mounting pad for direct coupling of the actuator. A full range of accessories, actuators, pilot valves, digital positioners, feedback switches and bus network options are available for integration into plant control systems.

For maintenance, this design allows removal of all seals with just four bolts. The semi lugged body provides for easy re-assembly without the debris pockets of enclosed bolt designs.

The ball is full port style, presenting a K_v and pressure drop similar to an open line, without restriction to high flow or entrained solids.

Table of contents

1. General technical data	4
1.1. Manual version	4
1.2. Direct mounting version.....	4
2. Product versions	5
2.1. Manual version	5
2.2. Direct mounting version.....	5
3. Approvals and conformities	6
3.1. General notes	6
3.2. Conformity	6
3.3. Standards.....	6
3.4. Foods and beverages/Hygiene	6
4. Materials	6
4.1. Bürkert resistApp	6
4.2. Material specifications manual version.....	7
4.3. Material specifications direct mounting version	7
5. Dimensions	8
5.1. Dimensions manual version	8
5.2. Dimensions direct mounting version.....	9
6. Performance specifications	10
6.1. Pressure temperature diagram	10
DN 6...DN 50.....	10
DN 65...DN 150	10
6.2. Torques.....	10
7. Product accessories	11
7.1. Soft parts sets.....	11
7.2. Handle set for direct mounting ball valves.....	11
7.3. Spring return handle for direct mounting ball valve.....	12
7.4. V-ball for modulation control	12
7.5. Mounting bracket for limit switch box.....	12
7.6. Extended bonnet 75 mm.....	13
7.7. Fugitive emission bonnet.....	13
7.8. Mounting bracket for actuation.....	13
7.9. Stem coupler for mounting bracket.....	14
7.10. Stem sleeve	14
8. Networking and combination with other Bürkert products	15

9. Ordering information	16
9.1. Bürkert eShop	16
9.2. Bürkert product filter	16
9.3. Ordering chart manual version with lockable hand lever	16
9.4. Ordering chart direct mounting version with lockable hand lever	17
9.5. Ordering chart soft parts set	18
9.6. Ordering chart handle set for direct mounting ball valves	19
9.7. Ordering chart spring return handle	19
9.8. Ordering chart V-balls for modulation control	20
9.9. Ordering chart mounting bracket for limit switch box	20
9.10. Ordering chart extended bonnet 75 mm	20
9.11. Ordering chart fugitive emission bonnet	21
9.12. Ordering chart mounting bracket for actuation	21
9.13. Ordering chart stem coupler for mounting bracket	21
9.14. Ordering chart stem sleeves	22

DTS 1000655023 EN Version: C Status: RL (released | freigegeben | validé) printed: 10.03.2025

1. General technical data

1.1. Manual version

Product properties	
Dimensions	Further information can be found in chapter "5.1. Dimensions manual version" on page 8.
Material	Further information can be found in chapter "4.2. Material specifications manual version" on page 7.
Body	Stainless steel ASTM A351 Gr.CF8M
Ball	Stainless steel 316
Stem	Stainless steel 316
Seal	Seat versions: PTFE TFM1600
Nominal diameter/Port	DN 8...DN 50
Medium data	
Medium	Stainless steel body: aggressive media which do not attack the body and seal material
Medium temperature	- 20 °C...240 °C (see "6.1. Pressure temperature diagram" on page 10.)
Medium pressure	See "6.1. Pressure temperature diagram" on page 10.
Process/Port connections	
Port connection	Threaded end versions according to: <ul style="list-style-type: none"> • BSPP • NPT Butt weld end versions according to: <ul style="list-style-type: none"> • Schedule 10 • Schedule 40 Socket weld end versions according to: <ul style="list-style-type: none"> • Schedule 40

1.2. Direct mounting version

Product properties	
Dimensions	Further information can be found in chapter "5.2. Dimensions direct mounting version" on page 9.
Material	Further information can be found in chapter "4.3. Material specifications direct mounting version" on page 7.
Body	Stainless steel ASTM A351 Gr.CF8M
Ball	Stainless steel 316
Stem	Stainless steel 316
Seal	Seat versions: PTFE TFM1600 TFM4215
Nominal diameter/Port	DN 6...DN 150 (DN 150 reduced port)
Medium data	
Medium	Stainless steel body: aggressive media which do not attack the body and seal material.
Medium temperature	- 20 °C...240 °C (see "6.1. Pressure temperature diagram" on page 10.)
Medium pressure	See "6.1. Pressure temperature diagram" on page 10.

Process/Port connections

Port connection

Threaded end versions according to:

- BSPB
- NPT

Butt weld end versions according to:

- Schedule 10
- Schedule 40

Orbital weld end versions according to:

- DIN 11850 R2
- ISO 1127/ISO 4200

Socket weld end versions according to:

- Schedule 40

Approvals and conformities

ISO head flange EN ISO 5211

Anti-static Spring loaded ball in stem and conductive spring

Certificates

Safety instrument systems SIL 2

Food and beverages/Hygiene

FDA Further information can be found in chapter “3.4. Foods and beverages/Hygiene” on page 6.

USP Further information can be found in chapter “3.4. Foods and beverages/Hygiene” on page 6.

EC Regulation 1935/2004 Further information can be found in chapter “3.4. Foods and beverages/Hygiene” on page 6.

ADI Further information can be found in chapter “3.4. Foods and beverages/Hygiene” on page 6.

2. Product versions

2.1. Manual version



Note:

For general technical data see “1.1. Manual version” on page 4.

Product properties

Port	DN 8...DN 50
ISO head flange	Without

2.2. Direct mounting version



Note:

For general technical data see “1.2. Direct mounting version” on page 4.

Product properties

Port	DN 6...DN 150
ISO head flange	ISO 5211

DTS 1000655023 EN Version: C Status: RL (released | freigegeben | valide) printed: 10.03.2025

3. Approvals and conformities

3.1. General notes

- The approvals and conformities listed below must be stated when making enquiries. This is the only way to ensure that the product complies with all required specifications.
- Not all available verions can be supplied with the below mentioned approvals or conformities.

3.2. Conformity

In accordance with the Declaration of Conformity, the product is compliant with the EU Directives.

- Pressure Equipment Directive 2014/68/EU

3.3. Standards

The applied standards which are used to demonstrate compliance with the EU Directives are listed in the EU-Type Examination Certificate and/or the EU Declaration of Conformity.

3.4. Foods and beverages/Hygiene

Conformity	Description
FDA	FDA – Code of Federal Regulations The seals made of PTFE and TFM1600 comply with the Code of Federal Regulations published by the FDA (Food and Drug Administration, USA). The O-rings made of FKM comply with the Code of Federal Regulations published by the FDA (Food and Drug Administration, USA).
USP	United States Pharmacopeial Convention (USP) The seals made of PTFE and TFM1600 are tested according to USP Class VI.
	EC Regulation 1935/2004 of the European Parliament and of the Council The seals made of PTFE and TFM1600 are suitable for use with food and beverages (according to EC Regulation 1935/2004/EC).
ADI	Animal Derived Ingredients The seals made of PTFE and TFM1600 do not contain any raw material of animal or human origin.

4. Materials

4.1. Bürkert resistApp

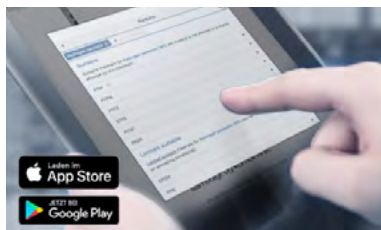

Bürkert resistApp – Chemical resistance chart

You want to ensure the reliability and durability of the materials in your individual application case? Verify your combination of media and materials on our website or in our resistApp.

4.2. Material specifications manual version

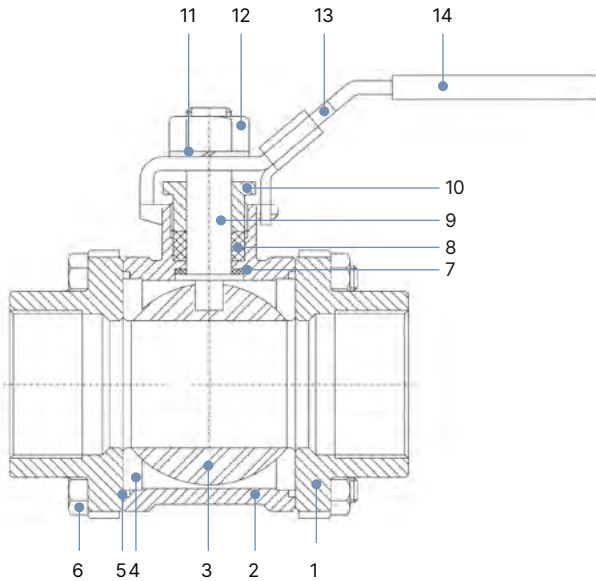

No.	Element	Material
1	End cap	CF8M
2	Body	CF8M
3	Ball	SS 316
4	Seat	PTFE / TFM1600
5	Gasket	PTFE / TFM1600
6	Bolts	SS 304
7	Thrust washer	TFM1600
8	Stem packing	TFM1600
9	Stem	SS 316
10	Gland washer	SS 304
11	Spring washer	SS 304
12	Stem nut	SS 304
13	Handle	SS 304
14	Sleeve	Plastic

4.3. Material specifications direct mounting version

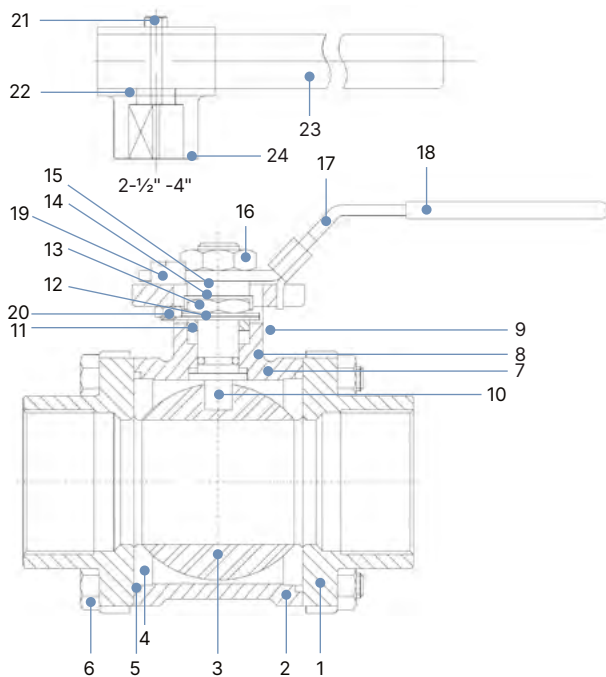

No.	Element	Material
1	End cap	CF8M
2	Body	CF8M
3	Ball	SS 316
4	Seat	PTFE / TFM1600 / TFM4215
5	Gasket	PTFE / TFM1600
6	Bolts	SS 304
7	Thrust washer	TFM1600
8	O-ring	FKM
9	Stem packing	TFM1600
10	Stem	SS 316
11	Gland washer	SS 304
12	Disk washer	SS 301
13	Stem nut	SS 304
14	Nut stop	SS 304
15	Space washer	SS 304
16	Handle nut	SS 304
17	Handle	SS 304
18	Sleeve	Plastic
19	Stop pin	SS 304
20	Stop pin nut	SS 304
21	Set bolt	SS 304
22	Lever head cap	CF8
23	Lever	Steel pipe
24	Stop plate	SS 304

DTS 1000655023 EN Version: C Status: RL (released | freigegeben | validé) printed: 10.03.2025

5. Dimensions

5.1. Dimensions manual version

Note:

Dimensions in mm

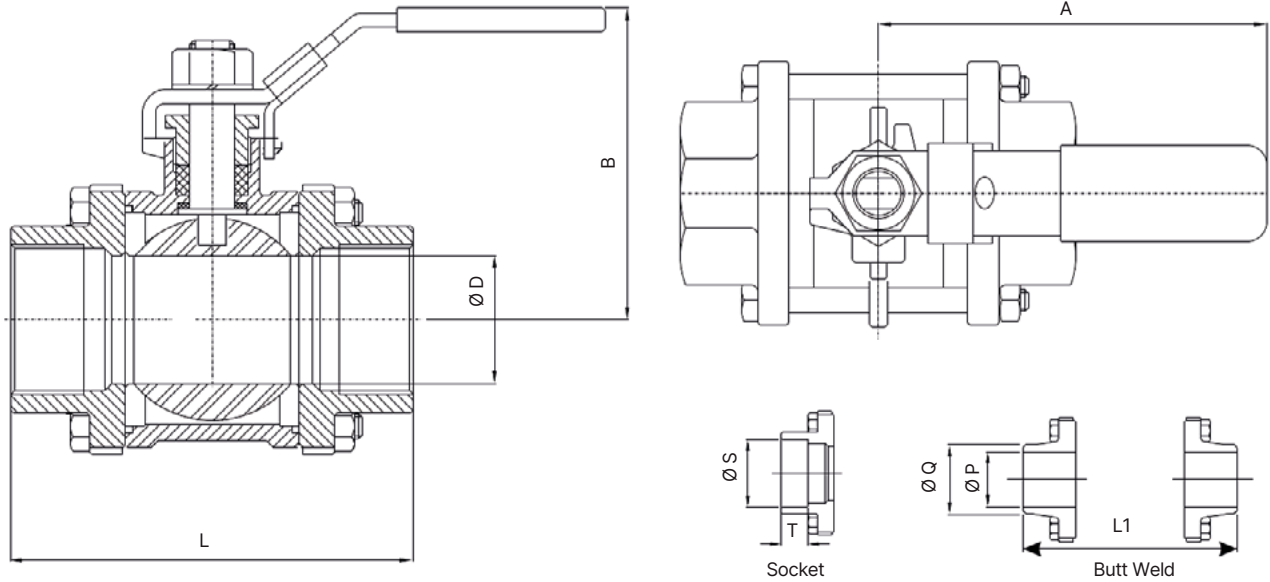

Nominal diameter	A	B	D	L	S	T	P	Q	L1	W
[mm]										[kg]
8	122	47	11	56.4	14.2	11.1	10	17	60.5	0.36
10	122	47	12.5	56.4	17.5	11.1	13.7	17	60.5	0.36
15	122	49	15	63.5	21.8	12.7	15.5	21.5	63.5	0.48
20	142	55	20	75.5	27.1	14.3	20.6	27.5	75.5	0.84
25	164	71	25	86	33.8	15.9	26.7	34.5	86	1.1
32	164	76	32	96	42.5	17.5	35.1	42.8	104	1.78
40	212	83	38	111	48.7	19.1	40.5	49	117	2.54
50	212	94	50	129	61.1	22.2	52.4	61	138	4.12

DTS 1000655023 EN Version: C Status: RL (released | freigegeben | validé) printed: 10.03.2025

5.2. Dimensions direct mounting version

Note:

Dimensions in mm

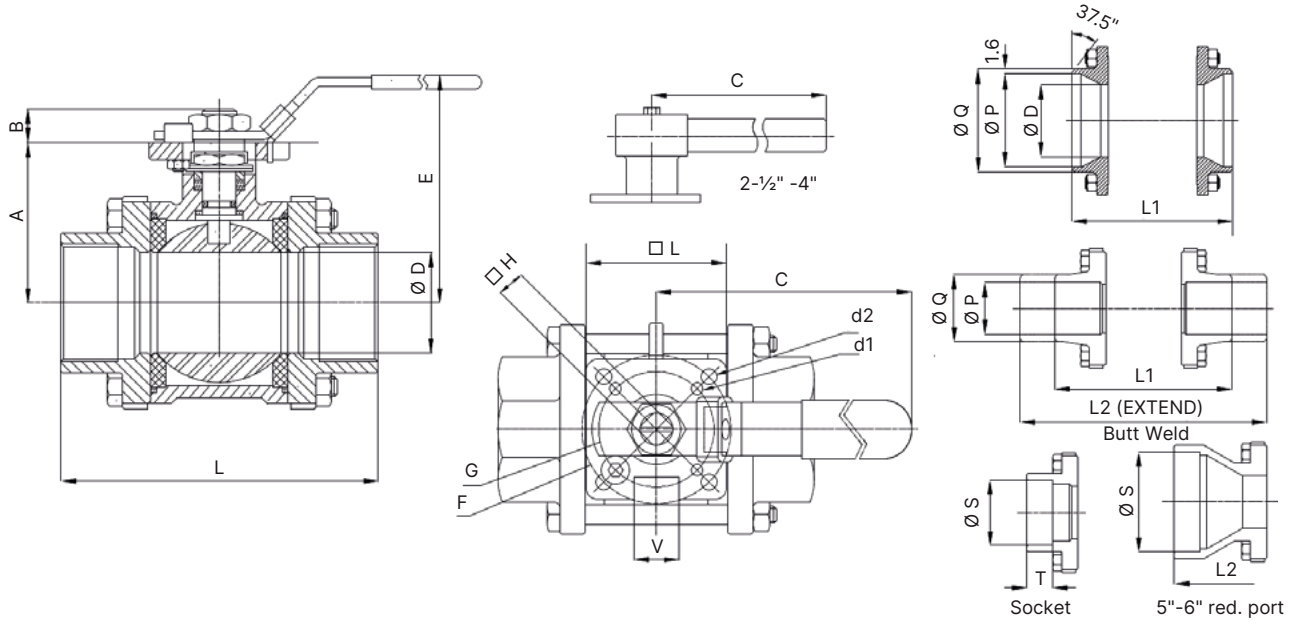

Nominal diameter [mm]	A	B	C	D	d1	d2	E	F	G	H	L	L1	L2	V	W	S	T	Weld end Sch.10		Weld end Sch.40	
																		P	Q	P	Q
6	37	10	130	11	6.0	6.0	66	36	42	9	60.5	60.5	120	19	44	10.8	12.7	-	-	7	10.5
8	37	10	130	11	6.0	6.0	66	36	42	9	60.5	60.5	120	19	44	14.0	12.7	-	-	10	17
10	37	10	130	12.5	6.0	6.0	66	36	42	9	60.5	60.5	120	19	44	17.5	12.7	-	-	13.1	17
15	37	10	130	15	6.0	6.0	66	36	42	9	63.5	63.5	140	19	44	21.7	12.7	17.1	21.5	15.5	21.5
20	40	10	130	20	6.0	6.0	69	36	42	9	75.5	75.5	140	19	44	27.1	14.3	22.5	27.5	20.6	27.5
25	48	13	155	25	6.0	7.0	77	42	50	11	86	86	152	24	52	33.8	15.9	27.8	34.5	26.7	34.5
32	53	13	155	32	6.0	7.0	82	42	50	11	96	104	165	24	52	42.6	17.5	36.6	42.8	35.1	42.8
40	63	17	205	38	7.0	9.0	103	50	70	14	111	117	190	28	53	48.6	19.1	42.7	49	40.5	49
50	72	17	205	50	7.0	9.0	112	50	70	14	129	138	203	28	53	61.1	22.2	54.7	61	52.4	61
65	92	19	300	65	9.0	11.3	147	70	102	17	152.5	170	254	-	92	74.0	22.2	67.1	77	65	77
80	102	19	300	80	9.0	11.3	157	70	102	17	168.5	192	280	-	92	90.0	25.4	83.7	91	80	91
100	132	26	350	100	11.3	13.5	195	102	125	22	212.5	226	308	-	102	115.6	28.5	108.1	115	100	115
150	132	26	350	100	11.3	13.5	195	102	125	22	308	262	-	-	102	170.1	31.8	161.5	170	154	170

DTS 1000655023 EN Version: C Status: RL (released | freigegeben | valide) printed: 10.03.2025

6. Performance specifications

6.1. Pressure temperature diagram

Note:

For general industrial use

DN 6...DN 50

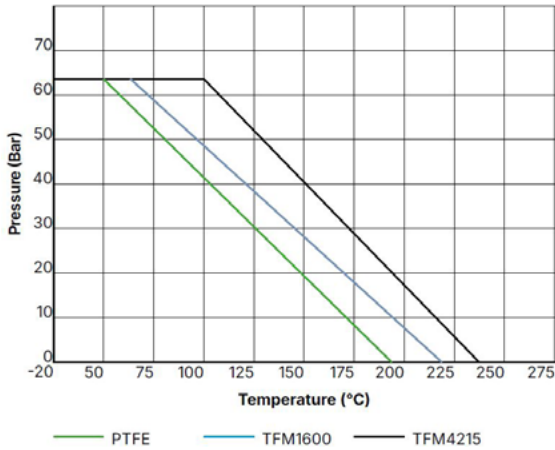

DN 65...DN 150

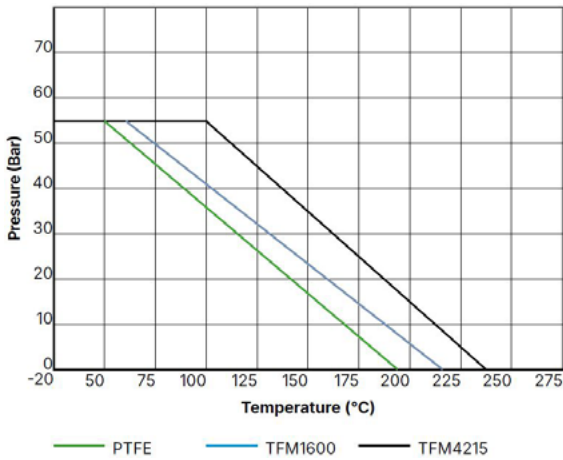

6.2. Torques

Note:

We recommend that a safety factor the equivalent of 1.3 times the maximal torque is applied when selecting an actuator.

Torques for direct mounting ball valves													
Nominal diameter [mm]	6	8	10	15	20	25	32	40	50	65	80	100	150
Torque grease [Nm]	3.5	3.5	3.5	5	5.5	7	11	17	23	35	46	72	72
Torque non-grease [Nm]	5	5	5	6	7	9.5	16	27	30	68	85	105	105

7. Product accessories

Whilst all product accessories are available individually, these can be combined with other ball valves and accessories to offer fully assembled ball valve systems. For further information please see chapter [“8. Networking and combination with other Bürkert products” on page 15](#), or to request a specific combination please contact your local Bürkert office.

7.1. Soft parts sets

Note:

Further ordering information can be found in chapter [“9.5. Ordering chart soft parts set” on page 18](#).

Description	Material	Quantity	
	Seat material PTFE		
	Ball seat	PTFE	2
	Gasket	PTFE	2
	Stem packing	TFM1600	1 (set)
	Thrust washer	TFM1600	1
	Stem O-ring	FKM (FDA) ¹⁾	1
	Seat material TFM1600		
	Ball seat	TFM1600	2
	Gasket	TFM1600	2
	Stem packing	TFM1600	1 (set)
	Thrust washer	TFM1600	1
	Stem O-ring	FKM (FDA) ¹⁾	1
	Seat material TFM4215		
	Ball seat	TFM4215	2
	Gasket	TFM1600	2
Stem packing	TFM1600	1 (set)	
Thrust washer	PEEK	1	
Stem O-ring	FKM (FDA) ¹⁾	1	

1.) O-ring in direct mounting version only

7.2. Handle set for direct mounting ball valves

Note:

Further ordering information can be found in chapter [“9.6. Ordering chart handle set for direct mounting ball valves” on page 19](#).

Description	Material	
	DN 6...DN 50	
	Space washer	SS 304
	Stop pin	SS 304
	Stop pin nut	SS 304
	Lever	SS 304
	Lever nut	SS 304
	DN 65...DN 150	
	Space washer	SS 304
	Stop pin	SS 304
	Stop pin nut	SS 304
	Stop plate	SS 304
	Pipe lever	Steel
	Pipe lever cap	CF8
	Lever cap set bolt	SS 304
	Pipe sleeve	Plastic

7.3. Spring return handle for direct mounting ball valve

Note:

- Spring handle heavy duty design for long term operation. Designed to mount directly to an ISO 5211 mounting flange.
- Further ordering information can be found in chapter “9.7. Ordering chart spring return handle” on page 19.

Description	Item	Part name	Materials
	1	Handle head	CF8
	2	Anchor	CF8
	3	Anchor screw	SS 304
	4	Spring rod	SS 304
	5	Spring	Spring steel
	6	Handle extension	SS 304
	7	Handle sleeve	PVC
	8	Washer	SS 304
	9	Nut	SS 304

7.4. V-ball for modulation control

Note:

- Available in 30°, 60° and 90°
- Further ordering information can be found in chapter “9.8. Ordering chart V-balls for modulation control” on page 20.

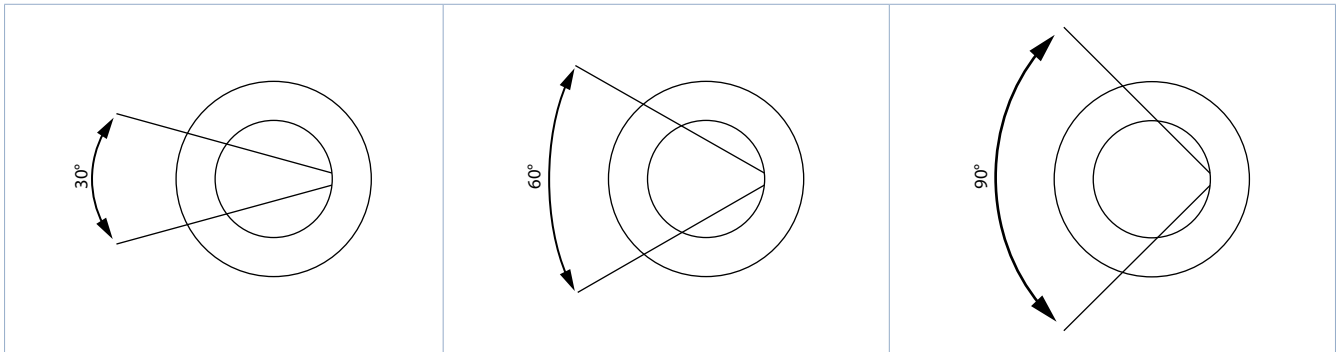

7.5. Mounting bracket for limit switch box

Note:

- Suitable for valve sizes DN 6 to DN 150, the brackets are designed to mount to the ISO 5211 flange. The bracket includes an integrated handle with locking function.
- Further ordering information can be found in chapter “9.9. Ordering chart mounting bracket for limit switch box” on page 20.

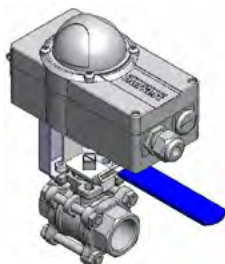

7.6. Extended bonnet 75 mm

Note:

- The extended bonnet is designed to raise the hand lever / actuator from the ISO flange for thermal insulation or create space when insulation jacket / material is installed. There is no sealing function to protect against leakage from the stem. Bonnets with sealing function can be found in chapter "7.7. Fugitive emission bonnet" on page 13.
- Further ordering information can be found in chapter "9.10. Ordering chart extended bonnet 75 mm" on page 20.



7.7. Fugitive emission bonnet

Note:

- Designed to keep fugitive emissions from leaking through the stem assembly, the test port allows the sniffer to detect any fine emissions from the bonnet.
- ISO direct mount flanges on both ends of the bonnet allow for easy installation and mounting of hand lever / actuator.
- The bonnet can also be used as a normal stem extension.
- Further ordering information can be found in chapter "9.11. Ordering chart fugitive emission bonnet" on page 21.



7.8. Mounting bracket for actuation

Note:

- Various dimensions for different valve & actuator combinations.
- ISO 5211 mounting dimensions.
- Further ordering information can be found in chapter "9.12. Ordering chart mounting bracket for actuation" on page 21.



DTS 1000655023 EN Version: C Status: RL (released | freigegeben | valide) printed: 10.03.2025

7.9. Stem coupler for mounting bracket

Note:

- SS 304 adaptor allows the stem to be extended to couple with the actuator when a mounting bracket is used.
- Various sizes for combination with mounting brackets.
- Further ordering information can be found in chapter [“9.13. Ordering chart stem coupler for mounting bracket” on page 21.](#)



7.10. Stem sleeve

Note:

- When the drive of the actuator is larger than the size of the stem, the stem sleeve can be used to adapt the stem dimensions to fit the actuator drive.
- Available in single square (SSQ) and double square (DSQ) versions in SS 304.
- Further ordering information can be found in chapter [“9.14. Ordering chart stem sleeves” on page 22.](#)

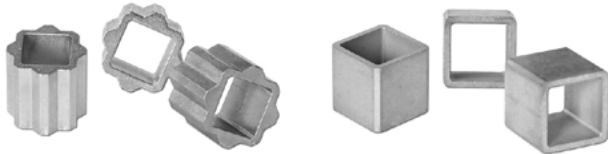

8. Networking and combination with other Bürkert products

Note:

The direct mounting version ball valve can be connected via the mechanical interface (according to ISO 5211) with pneumatic (e.g. Type 2051, Type 2052, Type 2053) and electrical rotary actuators (e.g. Type 3003, Type 3004, Type 3005).

Example:



Type 2654 ▶

Type 8804 Electrical rotary actuation			Type 8805 Pneumatic actuation		
Type 3003 ▶ Electrical actuator On/Off & Control	Type 3004 ▶ Explosion proof actuator	Type 3005 ▶ Electrical actuator On/Off & control	Type 2051 ▶ Pneumatic rotary actuator	Type 2052 ▶ Pneumatic rotary actuator	Type 2053 ▶ ELEMENT ready pneumatic actuator

Digital electropneumatic positioner		Position feedback	Pilot valve	ELEMENT Process automation			
Type 8791 ▶ Type 8792 ▶ SideControl Namur	Type 8635 ▶ SideControl Namur ATEX	Type 1061 ▶ Position feedback unit for pneumatic rotary actuators	Type 6519 ▶ Servo-assisted 3/2, 5/2 or 5/3-way solenoid valve	Type 8691 ▶ Control head	Type 8692 ▶ Positioner	Type 8693 ▶ Controller	Type 8694 ▶ Positioner

DTS 1000655023 EN Version: C Status: RL (released | freigegeben | validé) printed: 10.03.2025

9. Ordering information

9.1. Bürkert eShop



Bürkert eShop – Easy ordering and quick delivery

You want to find your desired Bürkert product or spare part quickly and order directly? Our online shop is available for you 24/7. Sign up and enjoy all the benefits.

9.2. Bürkert product filter



Bürkert product filter – Get quickly to the right product

You want to select products comfortably based on your technical requirements? Use the Bürkert product filter and find suitable articles for your application quickly and easily.



9.3. Ordering chart manual version with lockable hand lever

Nominal diameter [mm]	Article no.				
	BSPP	NPT	Butt weld Sch.10	Butt weld Sch.40	Socket weld
Seat material PTFE					
6	–	–	–	–	–
8	93952980	93952996	93953012	93952988	93953004
10	93952981	93952997	93953013	93952989	93953005
15	93952982	93952998	93953014	93952990	93953006
20	93952983	93952999	93953015	93952991	93953007
25	93952984	93953000	93953016	93952992	93953008
32	93952985	93953001	93953017	93952993	93953009
40	93952986	93953002	93953018	93952994	93953010
50	93952987	93953003	93953019	93952995	93953011
Seat material TFM1600					
6	–	–	–	–	–
8	93953044	93953060	93953076	93953052	93953068
10	93953045	93953061	93953077	93953053	93953069
15	93953046	93953062	93953078	93953054	93953070
20	93953047	93953063	93953079	93953055	93953071
25	93953048	93953064	93953080	93953056	93953072
32	93953049	93953065	93953081	93953057	93953073
40	93953050	93953066	93953082	93953058	93953074
50	93953051	93953067	93953083	93953059	93953075

9.4. Ordering chart direct mounting version with lockable hand lever

Nominal diameter [mm]	Article no.				
	BSPP	NPT	Butt weld Sch.10	Butt weld Sch.40	Socket weld
Seat material PTFE					
6	-	-	-	-	-
8	93951479	93951545	93950885	93951523	93951501
10	93951480	93951546	93950886	93951524	93951502
15	93951481	93951547	93950887	93951525	93951503
20	93951482	93951548	93956391	93951526	93951504
25	93951483	93951549	93956392	93951527	93951505
32	93951484	93951550	93956393	93951528	93951506
40	93951485	93951551	93956394	93951529	93951507
50	93951486	93951552	93956395	93951530	93951508
65	93951487	93951553	93956396	93951531	93951509
80	93951488	93951554	93956397	93951532	93951510
100	93951489	93951555	93956398	93951533	93951511
150	-	-	-	-	-
Seat material TFM1600					
6	-	-	-	-	-
8	93951744	93951810	93953127	93951788	93951766
10	93951745	93951811	93953128	93951789	93951767
15	93951746	93951812	93953129	93951790	93951768
20	93951747	93951813	93953130	93951791	93951769
25	93951748	93951814	93953131	93951792	93951770
32	93951749	93951815	93953132	93951793	93951771
40	93951750	93951816	93953133	93951794	93951772
50	93951751	93951817	93953134	93951795	93951773
65	93951752	93951818	93953135	93951796	93951774
80	93951753	93951819	93953136	93951797	93951775
100	93951754	93951820	93953137	93951798	93951776
150	-	-	-	93950876	93950877
Seat material TFM4215					
6	-	-	-	-	-
8	93953183	93953249	93953149	93953227	93953205
10	93953184	93953250	93953150	93953228	93953206
15	93953185	93953251	93953151	93953229	93953207
20	93953186	93953252	93953152	93953230	93953208
25	93953187	93953253	93953153	93953231	93953209
32	93953188	93953254	93953154	93953232	93953210
40	93953189	93953255	93953155	93953233	93953211
50	93953190	93953256	93953156	93953234	93953212
65	93953191	93953257	93953157	93953235	93953213
80	93953192	93953258	93953158	93953236	93953214
100	93953193	93953259	93953159	93953237	93953215
150	-	-	-	93950878	93950879

































































DTS 1000655023 EN Version: C Status: RL (released | freigegeben | valide) printed: 10.03.2025

Further versions on request		
>	Version Actuated valve assemblies <ul style="list-style-type: none"> pneumatic actuated valves electrically actuated valves 	 Port connection Special combination port connections <ul style="list-style-type: none"> example BSPP x BW Sch.40
	Material Seat Materials in: <ul style="list-style-type: none"> RPTFE Cavity-Filled PTFE Cavity Filled TFM1600 	

9.5. Ordering chart soft parts set

Note:

Further information can be found in chapter "7.1. Soft parts sets" on page 11.

Description	Nominal diameter [mm]	Article no.		
		PTFE	TFM1600	TFM4215
	Manual version			
	8	93920714 	93920722 	93920730 
	10	93920715 	93920723 	93920731 
	15	93920716 	93920724 	93920732 
	20	93920717 	93920725 	93920733 
	25	93920718 	93920726 	93920734 
	32	93920719 	93920727 	93920735 
	40	93920720 	93920728 	93920736 
	50	93920721 	93920729 	93920737 
	Direct mounting version			
	6	93920117 	93920128 	93920139 
	8	93920117 	93920128 	93920139 
	10	93920118 	93920129 	93920140 
	15	93920119 	93920130 	93920141 
	20	93920120 	93920131 	93920142 
	25	93920121 	93920132 	93920143 
	32	93920122 	93920133 	93920144 
	40	93920123 	93920134 	93920145 
	50	93920124 	93920135 	93920146 
	65	93920125 	93920136 	93920147 
	80	93920126 	93920137 	93920854 
	100	93920127 	93920138 	93920855 
150	93920127 	93920138 	93920855 	

DTS 1000655023 EN Version: C Status: RL (released | freigegeben | validé) printed: 10.03.2025

9.6. Ordering chart handle set for direct mounting ball valves

Note:

Further information can be found in chapter “7.2. Handle set for direct mounting ball valves” on page 11.

Description	Nominal diameter	Article no.
	[mm]	
	6	93922129
	8	93922129
	10	93922130
	15	93922131
	20	93922132
	25	93922133
	32	93922134
	40	93922135
	50	93922136
	65	93922137
	80	93922138
	100	93922139
	150	93922139

9.7. Ordering chart spring return handle

Note:

Further information can be found in chapter “7.3. Spring return handle for direct mounting ball valve” on page 12.

Description	Size	Torque	Stem	ISO flange	Article no.
		[Nm]	[mm □]	[5211]	
	10	15	09	F03 / F04	93921519
	20	20	11	F04 / F05	93921520
	30	30	14	F05 / F07	93921521
	40	100	17/22	F10 / F12	93921522

DTS 1000655023 EN Version: C Status: RL (released | freigegeben | validé) printed: 10.03.2025

9.8. Ordering chart V-balls for modulation control

Note:

Further information can be found in chapter "7.4. V-ball for modulation control" on page 12.

Description	Nominal diameter [mm]	Article no.		
		V-30°	V-60°	V-90°
	6	93920399	93920416	93920431
	8	93920399	93920416	93920431
	10	93920400	93920417	93920432
	15	93920401	93920418	93920433
	20	93920402	93920419	93920434
	25	93920406	93920421	93920436
	32	93920409	93920424	93920439
	40	93920410	93920425	93920440
	50	93920411	93920426	93920441
	65	93920412	93920427	93920442
	80	93920413	93920428	93920443
	100	93920414	93920429	93920444
	150	93920414	93920429	93920444

9.9. Ordering chart mounting bracket for limit switch box

Note:

Further information can be found in chapter "7.5. Mounting bracket for limit switch box" on page 12.

Description	Size	Stem	ISO flange	Article no.
		[mm □]	[5211]	
	01	09	F04	93920873
	02	11	F05	93920874
	03	14	F05 / F07	93920875
	04	17	F07 / F10	93920876
	05	22	F10 / F12	93920877

9.10. Ordering chart extended bonnet 75 mm

Note:

Further information can be found in chapter "7.6. Extended bonnet 75 mm" on page 13.







Description	Size	Stem	ISO flange	ISO flange	Article no.
		[mm □]	[valve side]	[actuator side]	
	01	09	F04	F03 / F04	93921805
	02	11	F05	F04 / F05	93921806
	03	14	F07	F05 / F07	93921807
	04	17	F10	F07 / F10	93921808
	05	22	F12	F10 / F12	93921809

DTS 1000655023 EN Version: C Status: RL (released | freigegeben | valide) printed: 10.03.2025

9.11. Ordering chart fugitive emission bonnet

Note:





Further information can be found in chapter "7.7. Fugitive emission bonnet" on page 13.

Description	Size	Stem	ISO flange	ISO flange	Article no.
		[mm □]	[valve side]	[actuator side]	
	01	09	F04	F03 / F04	93920709 
	02	11	F05	F04 / F05	93920710 
	03	14	F07	F05 / F07	93920711 
	04	17	F10	F07 / F10	93920712 
	05	22	F12	F10 / F12	93920713 

9.12. Ordering chart mounting bracket for actuation

Note:



















Further information can be found in chapter "7.8. Mounting bracket for actuation" on page 13.

Description	Size	ISO flange	ISO flange	Height	Article no.
		[valve side]	[actuator side]	[mm]	
	01	F03 / F04 / F05	F03 / F04 / F05	70	93920557 
	02	F04 / F05 / F07	F04 / F05 / F07	70	93920558 
	03	F04 / F05 / F07	F04 / F05 / F07	40	93920990 
	04	F07 / F10 / F12	F07 / F10 / F12	70	93920559 

9.13. Ordering chart stem coupler for mounting bracket

Note:











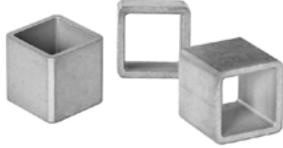



Further information can be found in chapter "7.9. Stem coupler for mounting bracket" on page 14.

Description	Shaft size	Drive size	Height	For bracket height	Article no.
	[mm □]	[mm □]	[mm]	[mm]	
	9	9	48	40	93920973 
	9	11	50	40	93920974 
	11	11	50	40	93920975 
	9	14	55	40	93920976 
	11	14	55	40	93920977 
	14	14	55	40	93920978 
	9	17	88	70	93920979 
	11	17	88	70	93920980 
	14	17	88	70	93920981 
	17	17	58	40	93920982 
	17	17	88	70	93920983 
	14	22	93	70	93920984 
	17	22	93	70	93920985 
	17	27	98	70	93920986 
	22	22	93	70	93920987 
	22	27	98	70	93920988 
22	36	107	70	93920989 	

9.14. Ordering chart stem sleeves

Note:

 Further information can be found in chapter ["7.10. Stem sleeve"](#) on page 14.

Description	Inside	Outside	Article no.
	[mm □]	[mm □]	
Single square (SSQ) version			
	9	11	666575 
	11	14	665291 
	11	17	665369 
	14	17	665290 
	17	22	672306 
	17	27	774193 
	22	27	678023 
	27	36	93913966 
Double square (DSQ) version			
	9	14	665288 
	11	14	665289 
	11	22	773344 
	14	17	773348 
	14	22	666684 
	17	22	666685 